

PART NO.	Pos.	A	B	C	D	E
20539-016E-01	16	19.50	17.98	13.84	11.56	7.50
20539-022E-01	22	22.50	20.98	16.84	14.56	10.50
20539-024E-01	24	23.50	21.98	17.84	15.56	11.50
20539-026E-01	26	24.50	22.98	18.84	16.56	12.50
20539-030E-01	30	26.50	24.98	20.84	18.56	14.50
20539-040E-01	40	31.50	29.98	25.84	23.56	19.50
20539-045E-01	45	34.00	32.48	28.34	26.06	22.00
20539-050E-01	50	36.50	34.98	30.84	28.56	24.50
20539-060E-01	60	41.50	39.98	35.84	33.56	29.50
20539-080E-01	80	51.50	49.98	45.84	43.56	39.50



Halogen Free



RoHS Compliant

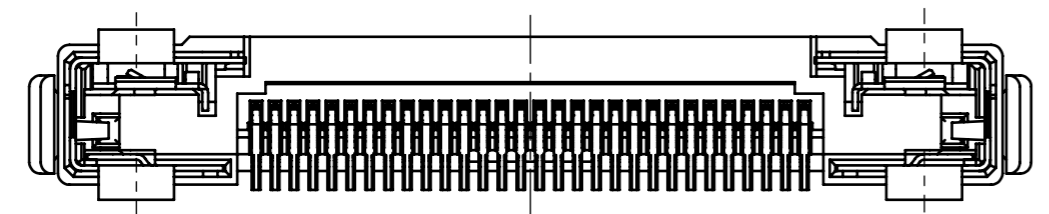
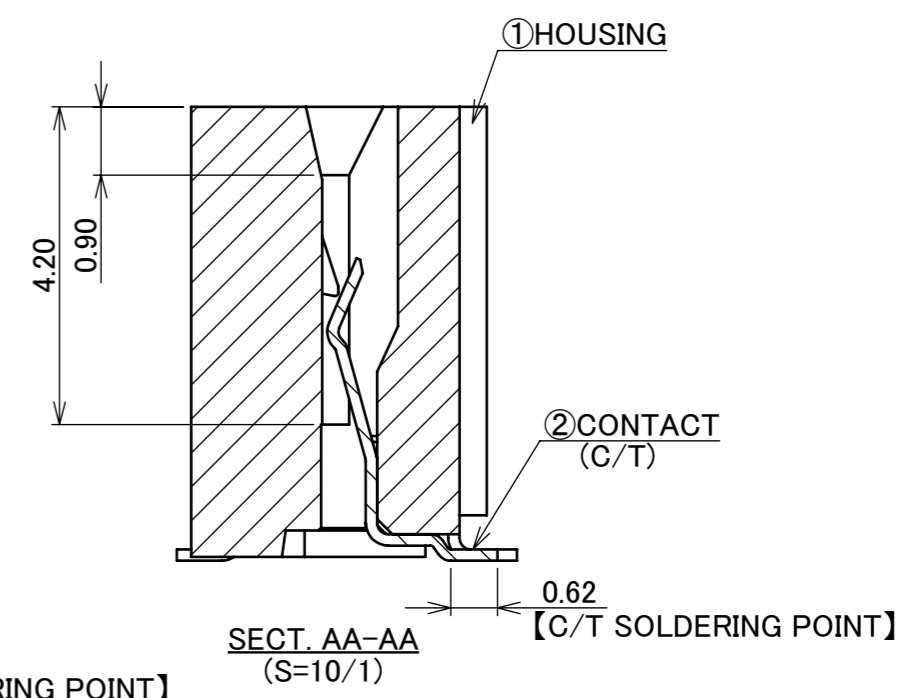
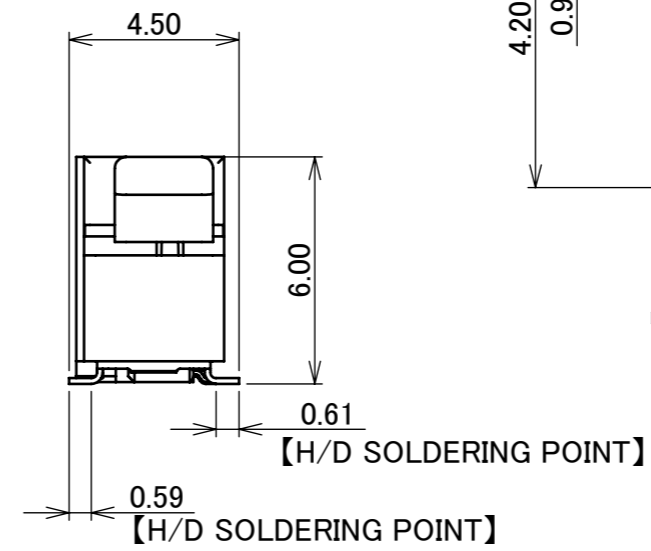
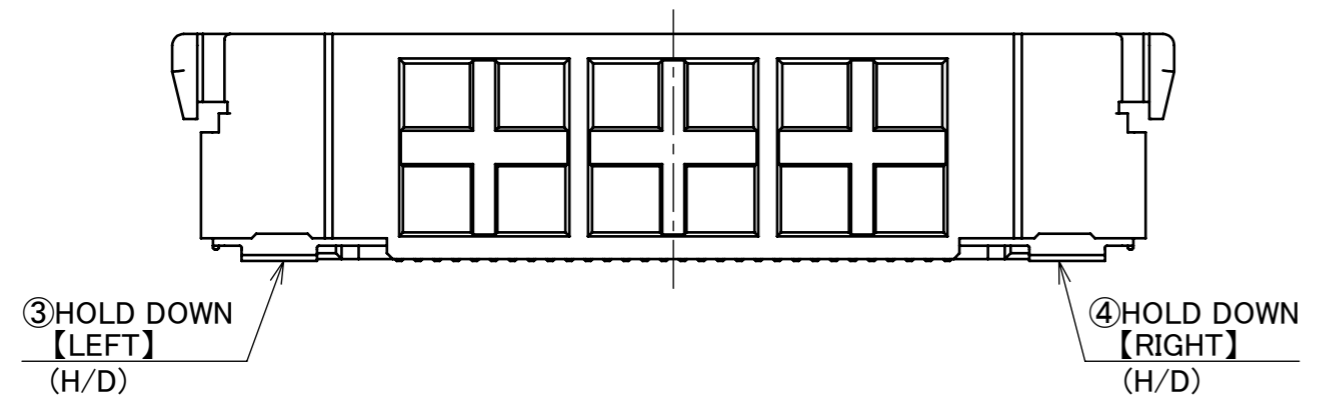
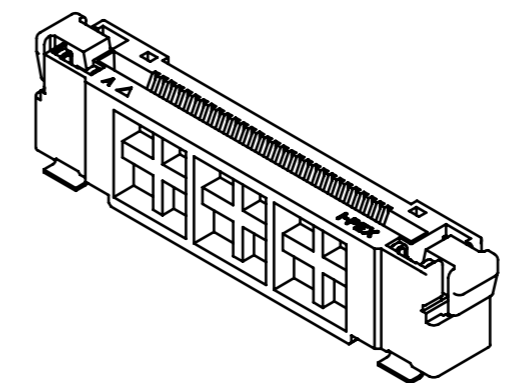
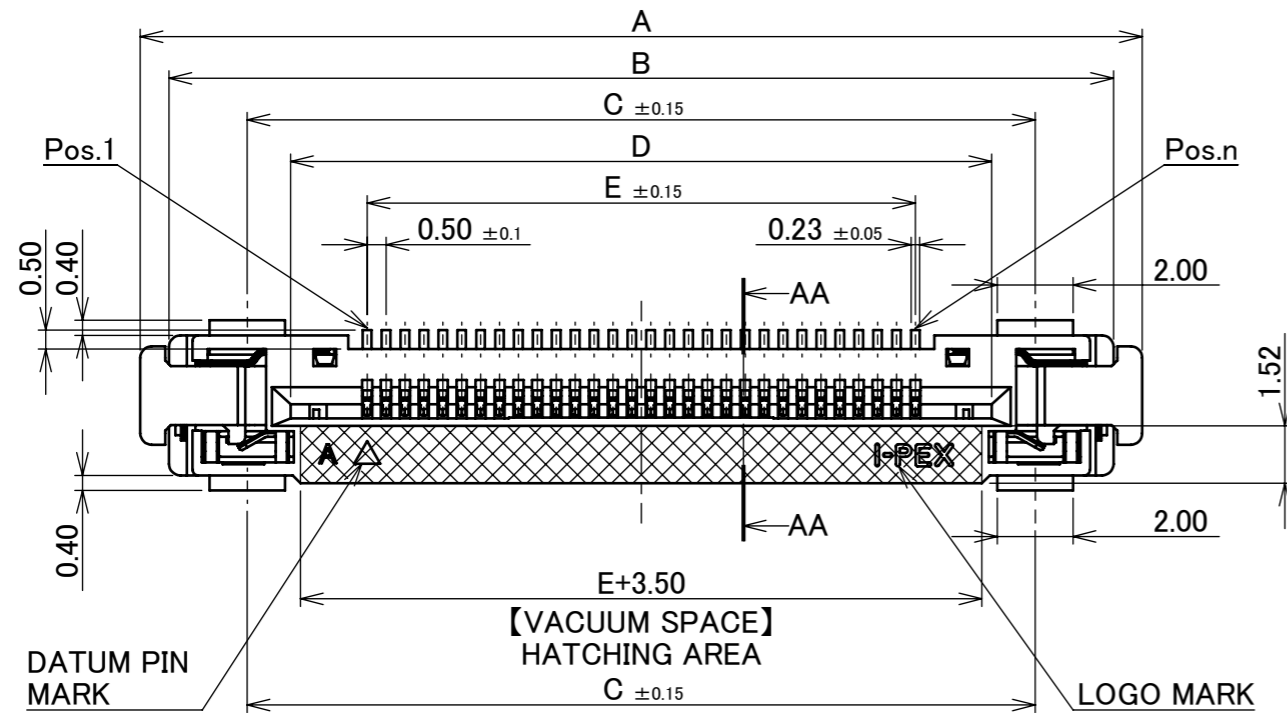

NO.	DISCRIPTION	MATERIAL	FINISH , REMARKS
4	HOLD DOWN [RIGHT]	PHOSPHOR BRONZE	Sn 2.00 μ m MIN. OVER Ni 1.00 μ m MIN.
3	HOLD DOWN [LEFT]	PHOSPHOR BRONZE	Sn 2.00 μ m MIN. OVER Ni 1.00 μ m MIN.
2	CONTACT	PHOSPHOR BRONZE	CONTACT AREA : Au 0.10 μ m MIN. OVER Ni 1.00 μ m MIN. SOLDERING AREA : Au 0.03 μ m MIN. OVER Ni 1.00 μ m MIN.
1	HOUSING	LCP	UL94V-0, BLACK

REV.	ECN	BY	DATE	APP.	APP.	PROJECTION	SERIES No.	TITLE	SCALE	SHEET	REV.
12	Z230339	K.W	2023/03/23	M.T	ANGLE	±2°	6 OVER 30 MAX.	±0.3	EVAFLEX® 5-SE-VT	5:1	I-PEX
11	Z220252	K.H	2022/03/09	H.I	6 MAX.	±0.2	30 OVER 120 MAX.	±0.5			
10	Z200420	K.H	2020/04/15	Y.S	GENERAL TOLERANCE.			DWG. No. 20539	A3	1/5	12
9	Z181052	T.O	2018/08/09	H.I	DWG.	DATE					
8	Z180217	M.K	2018/02/21	H.I	M.Ishimaru		2011/11/29				
7	Z160846	M.I	2016/07/15	Y.S	CHK.	J.Tateishi		20539	A3	1/5	12
REV.	ECN	BY	DATE	APP.	APP.	Y.Hashimoto					

ITEMS	SPECIFICATION
RATING VOLTAGE	50V AC/DC (PER CONTACT PIN)
RATING AMPERAGE (AVAILABLE UP TO 15PIN)	0.50A AC/DC (PER CONTACT PIN)
RATING AMPERAGE (AVAILABLE FOR ALL PIN)	0.35A AC/DC (PER CONTACT PIN)
OPERATING TEMPERATURE	233~358K(-40°C~+85°C)
OPERATING HUMIDITY	85%R.H. MAX.
CONTACT RESISTANCE	INITIAL : 70mohm MAX. / AFTER TEST : \triangleleft 40mohm MAX.
INSULATION RESISTANCE	500Mohm MIN.
DIELECTRIC WITHSTANDING VOLTAGE	AC250V 1min
DURABILITY	30 CYCLES
MATING FORCE (INITIAL / 30 CYCLES)	16P: 9.6N MAX., 22P: 13.2N MAX., 24P: 14.4N MAX., 26P: 15.6N MAX., 30P: 18.0N MAX., 40P: 24.0N MAX., 45P: 27.0N MAX., 50P: 30.0N MAX., 60P: 36.0N MAX., 80P: 48.0N MAX.
UNMATING FORCE (INITIAL / 30 CYCLES)	16P: 1.44N MIN., 22P: 1.98N MIN., 24P: 2.16N MIN., 26P: 2.34N MIN., 30P: 2.70N MIN., 40P: 3.60N MIN., 45P: 4.05N MIN., 50P: 4.50N MIN., 60P: 5.40N MIN., 80P: 7.20N MIN.
FPC/FFC RETENTION FORCE	25.0N MIN.
COPLANARITY	0.10mm MAX.
PRODUCT SPECIFICATION	PRS-1620
TEST REPORT	TR-12047
PACKING STANDARD	300-967
INSTRUCTION MANUAL	HIM-11002
APPEARANCE CRITERIA No.	QLS-A***

ANGLE	$\pm 2^\circ$	6 OVER 30 MAX.	± 0.3	PROJECTION 	SERIES No. R8	CUSTOMER COPY	
6 MAX.	± 0.2	30 OVER 120 MAX.	± 0.5			SCALE -	I-PEX
GENERAL TOLERANCE.				TITLE EVAFLEX® 5-SE-VT	UNIT mm		
DWG.	DATE			DWG. No. 20539	SIZE A3	SHEET 2/5	REV. 12
CHK.							
APP.							

PART NO.	Pos.	C	E	F	G
20539-016E-01	16	13.84	7.50	11.50	8.20
20539-022E-01	22	16.84	10.50	14.50	11.20
20539-024E-01	24	17.84	11.50	15.50	12.20
20539-026E-01	26	18.84	12.50	16.50	13.20
20539-030E-01	30	20.84	14.50	18.50	15.20
20539-040E-01	40	25.84	19.50	23.50	20.20
20539-045E-01	45	28.34	22.00	26.00	22.70
20539-050E-01	50	30.84	24.50	28.50	25.20
20539-060E-01	60	35.84	29.50	33.50	30.20
20539-080E-01	80	45.84	39.50	43.50	40.20

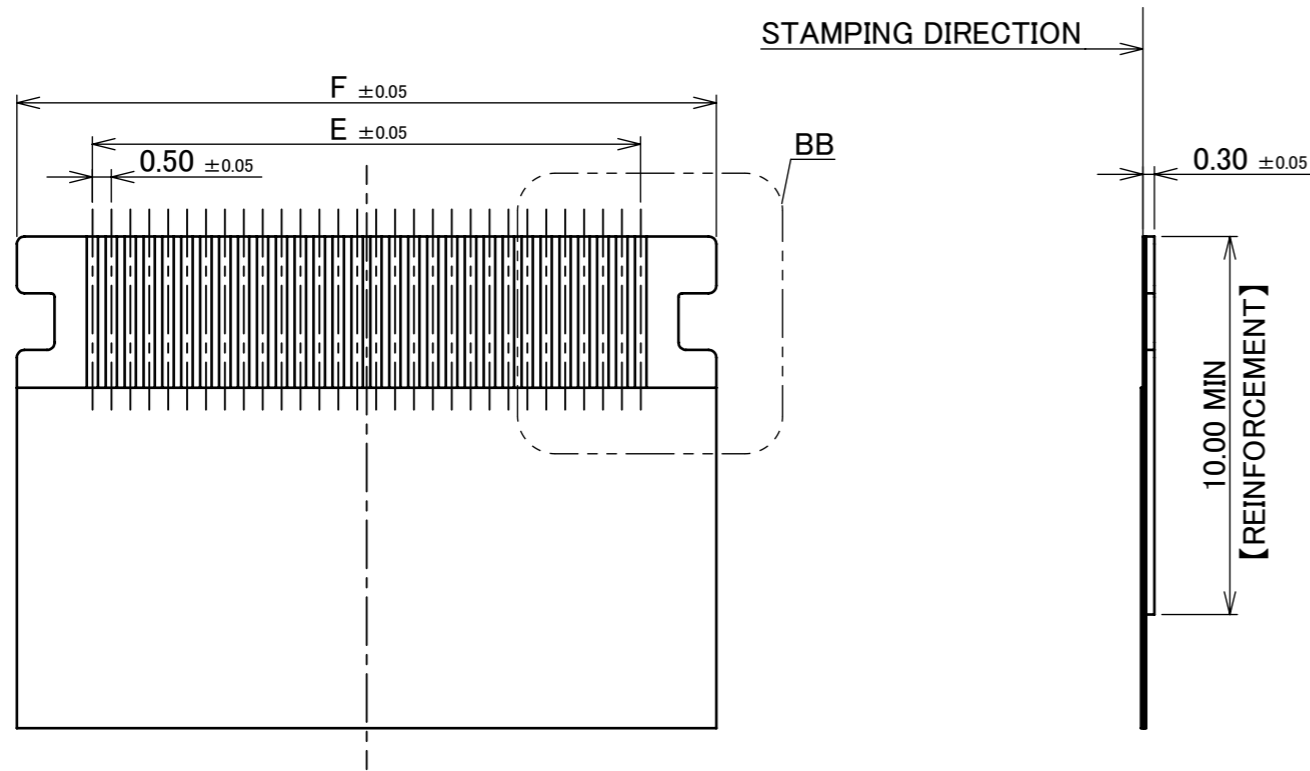

RECOMMENDED FPC/FFC LAYOUT

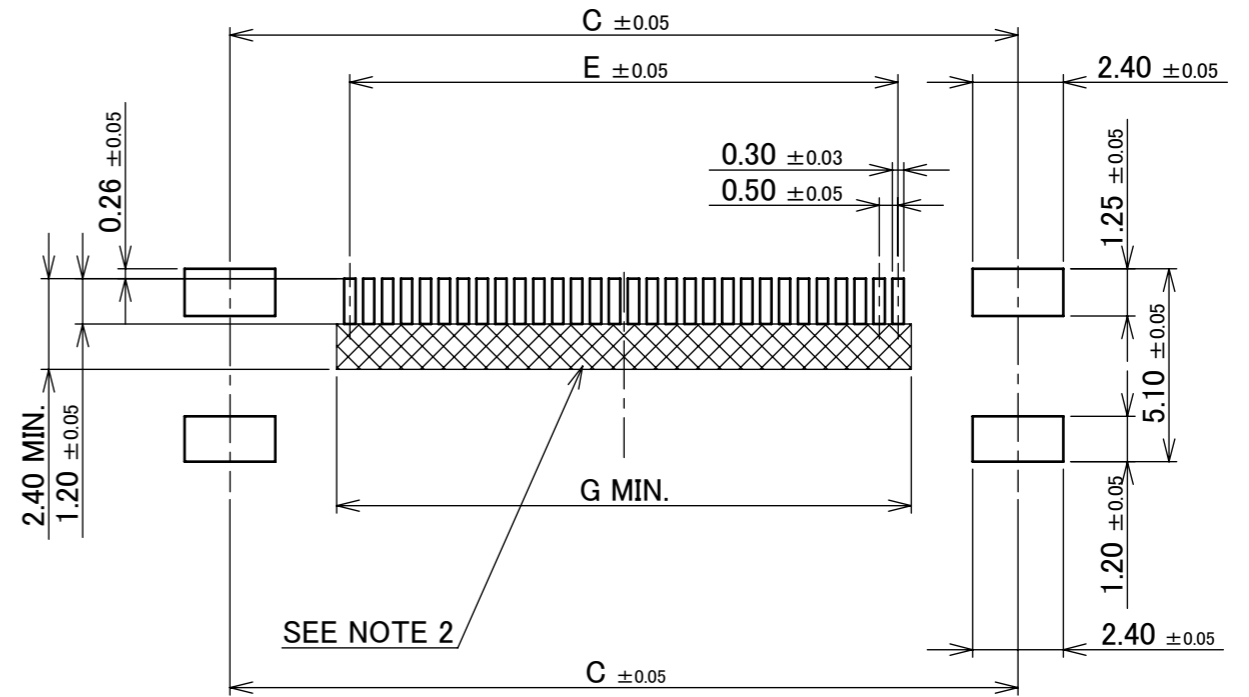

RECOMMENDED PCB LAYOUT & METAL MASK LAYOUT
METAL MASK THICKNESS : t=0.12mm

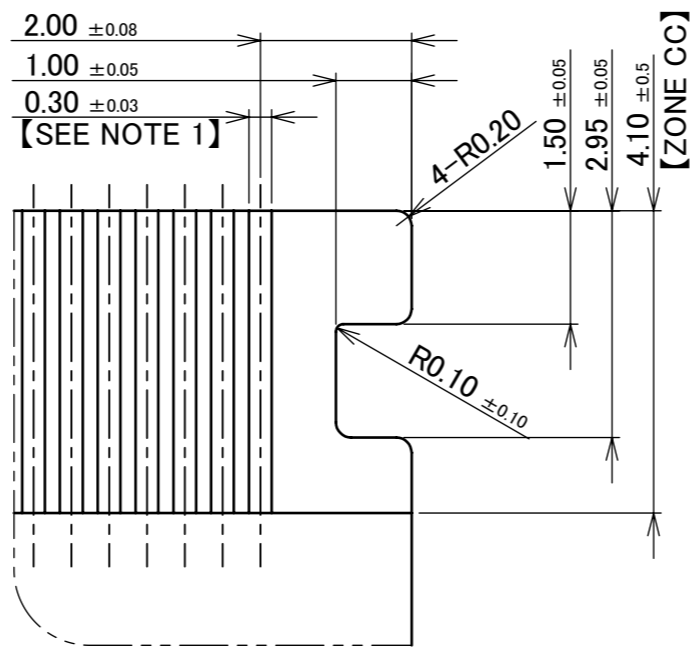

DETAIL BB
(S = 10 : 1)

NOTES

- CONTROL DIMENSION OF [ZONE CC] WITHIN 0.30 ± 0.03 .
- SOLDER RESIST MUST BE APPLIED TO THIS AREA.
- SELECT A MATERIAL WITH A SOFTENING TEMPERATURE OF 85°C OR HIGHER FOR THE PATTERN ADHESIVE PART OF FFC.

ANGLE	$\pm 2^{\circ}$	6 OVER 30 MAX.	± 0.3	PROJECTION	SERIES No.	CUSTOMER COPY	
					R8		
6 MAX.	± 0.2	30 OVER 120 MAX.	± 0.5	TITLE		SCALE	I-PEX
GENERAL TOLERANCE.				EVAFLEX® 5-SE-VT		5:1	
DWG.	DATE			DWG. No.		UNIT	
CHK.				20539		mm	SHEET
APP.						3/5	
							12

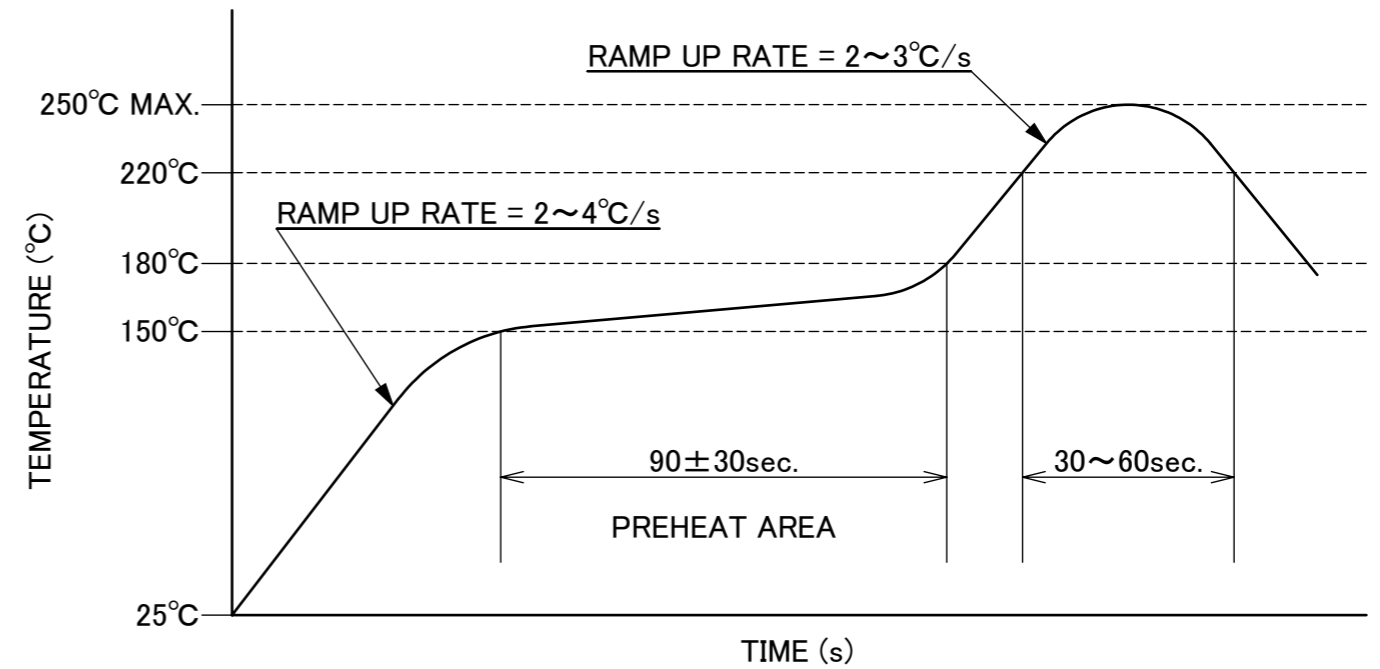
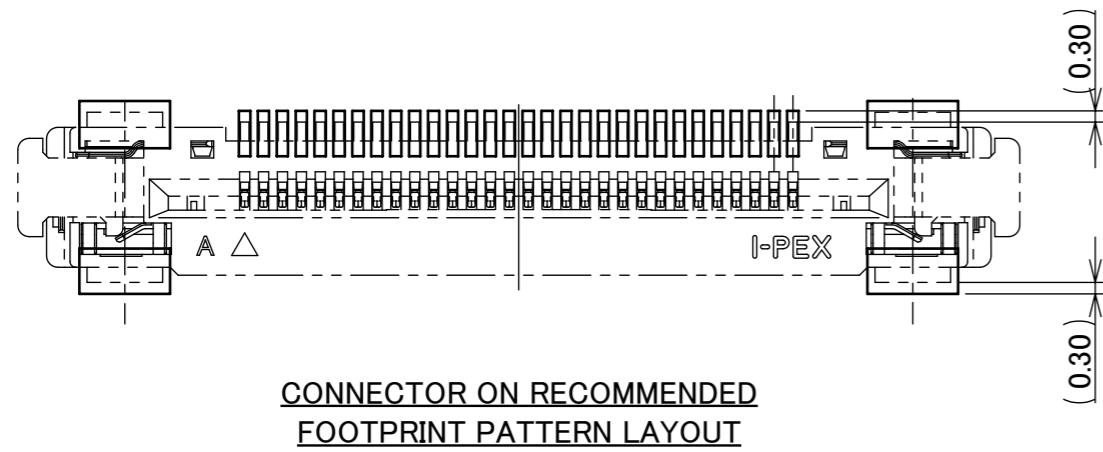

REFLOW TEMPERATURE PROFILE
 SENJU METAL INDUSTRY CO., LTD. : M705-SHF(Sn96.5 Ag3.0 Cu0.5)

ANGLE	±2°	6 OVER 30 MAX.	±0.3	PROJECTION 	SERIES No. R8	CUSTOMER COPY			
6 MAX.	±0.2	30 OVER 120 MAX.	±0.5						
GENERAL TOLERANCE.				TITLE		SCALE			
DWG.	DATE			EVAFLEX® 5-SE-VT		5:1			
CHK.						UNIT			
APP.				DWG. No.		mm			
				20539		SIZE	SHEET	REV.	
						A3	4/5	12	

DEVICE P/N	H	J	K	L	M	N	QTY. PER EMBOSS REEL (PIECES / REEL)	QTY. PER PACKING CARTON (REELS / CARTON)
20539-016E-01	32.00	26.00	14.20	28.40	20.60	18.38	1,000 / REEL	4 / CARTON = 4,000
20539-022E-01					23.60	21.38		3 / CARTON = 3,000
20539-024E-01					24.60	22.38		
20539-026E-01					25.60	23.38		
20539-030E-01	27.60	25.38						
20539-040E-01	44.00	37.00	20.20	40.40	32.60	30.38	1,000 / REEL	3 / CARTON = 3,000
20539-045E-01					35.10	32.88		
20539-050E-01					37.60	35.38		
20539-060E-01					42.60	40.38		
20539-080E-01	72.00	65.50	34.20	68.40	52.60	50.38		2 / CARTON = 2,000

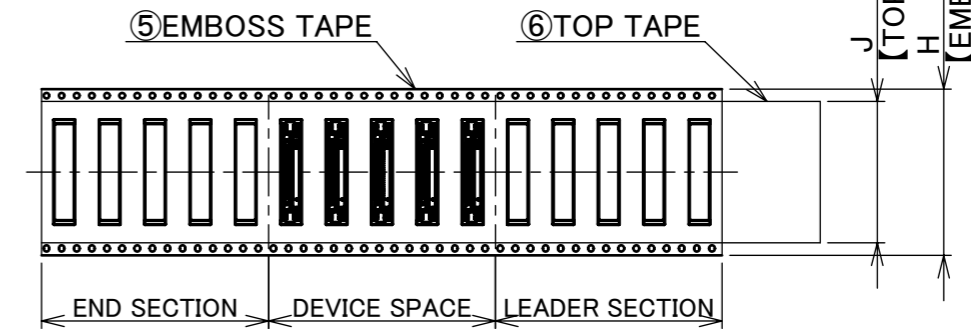
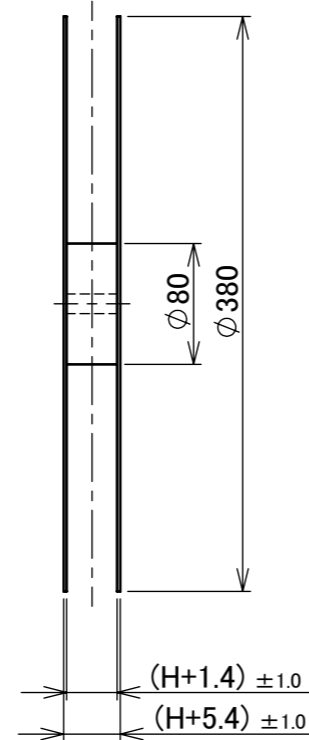
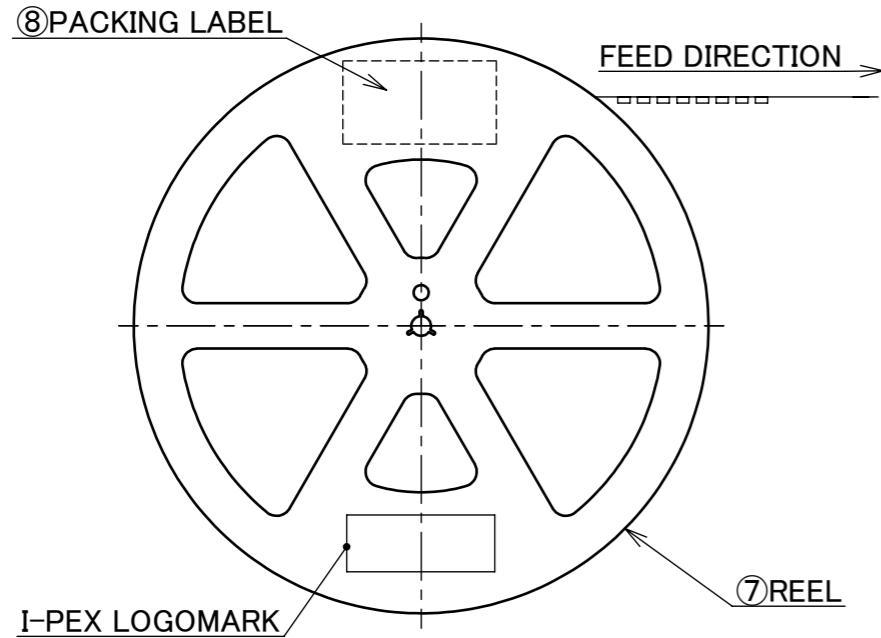

EMBOSS TAPE
(S = 1 : 2)

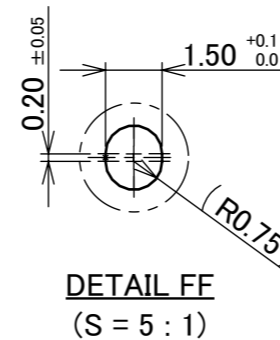
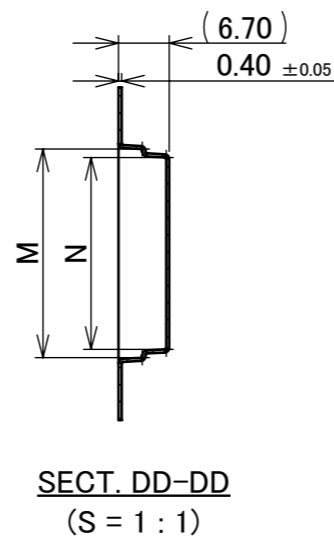
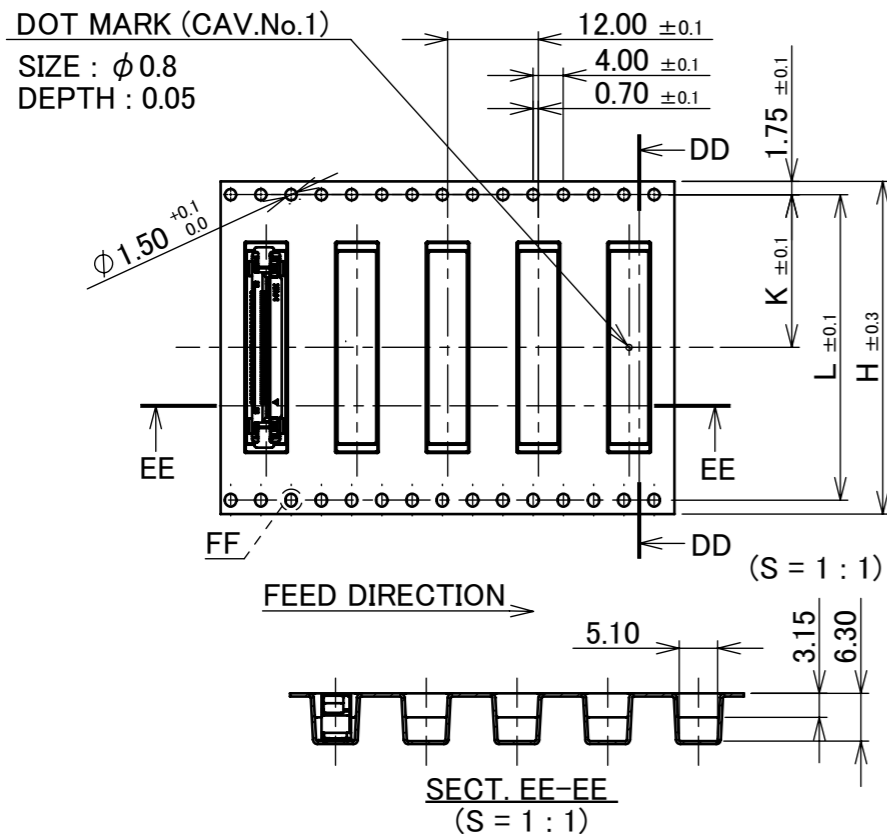

NOTES.

4. TAPING SPECIFICATION FOLLOWS JIS C 0806 (IEC 60286-3).
5. MAKE EMPTY SECTION OF LEADER AND END ON EACH END OF THE TAPE.
6. TOP TAPE SHALL NOT STICK OUT FROM EMBOSS TAPE.
7. TOP TAPE SHALL NOT COVER FEED HOLE.

NO.	DISCRIPTION	MATERIAL	FINISH , REMARKS
8	PACKING LABEL	-	-
7	REEL	PS	WHITE
6	TOP TAPE	PET t=0.062 TRANSPARENCY	ANTI-STATIC TYPE
5	EMBOSS TAPE	PS t=0.4 TRANSPARENCY	ANTI-STATIC TYPE

ANGLE	±2°	6 OVER 30 MAX.	±0.3	PROJECTION	SERIES No.	CUSTOMER COPY			
6 MAX.	±0.2	30 OVER 120 MAX.	±0.5		R8				
GENERAL TOLERANCE.				TITLE	EVAFLEX® 5-SE-VT		SCALE	1:X	
DWG.	DATE					UNIT	mm		
CHK.						SIZE	SHEET	REV.	
APP.				DWG. No.	20539	A3	5/5	12	