

Halogen Free



RoHS Compliant

PART No.	A	B	C	D	E
◆20899-020E-01	18.00	15.30	13.56	9.50	6.00
20899-030E-01	23.00	20.30	18.56	14.50	11.00
◆20899-040E-01	28.00	25.30	23.56	19.50	16.00
20899-050E-01	33.00	30.30	28.56	24.50	21.00
◆20899-060E-01	38.00	35.30	33.56	29.50	26.00

◆MARK MEANS NOT AVAILABLE.

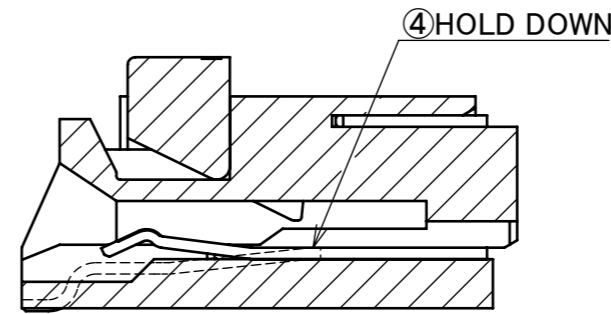

SECT. LL-LL (S=10/1)

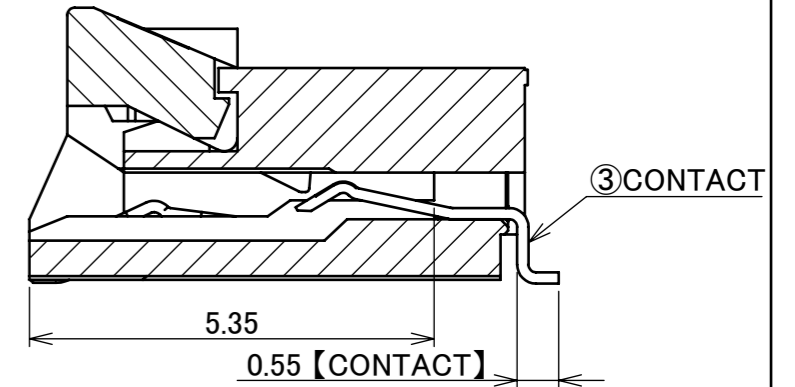
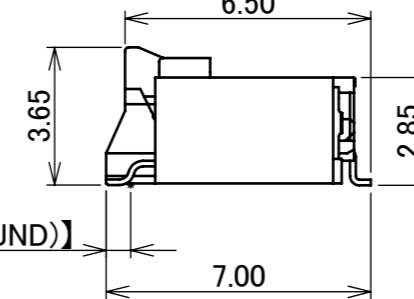

SECT.AA-AA (S=10/1)

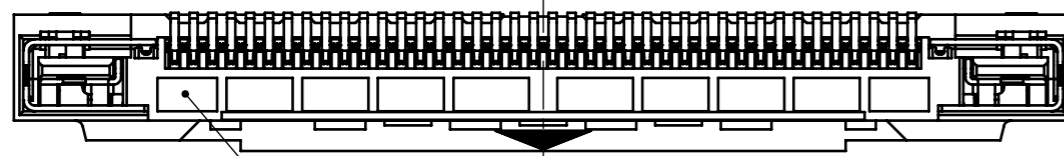
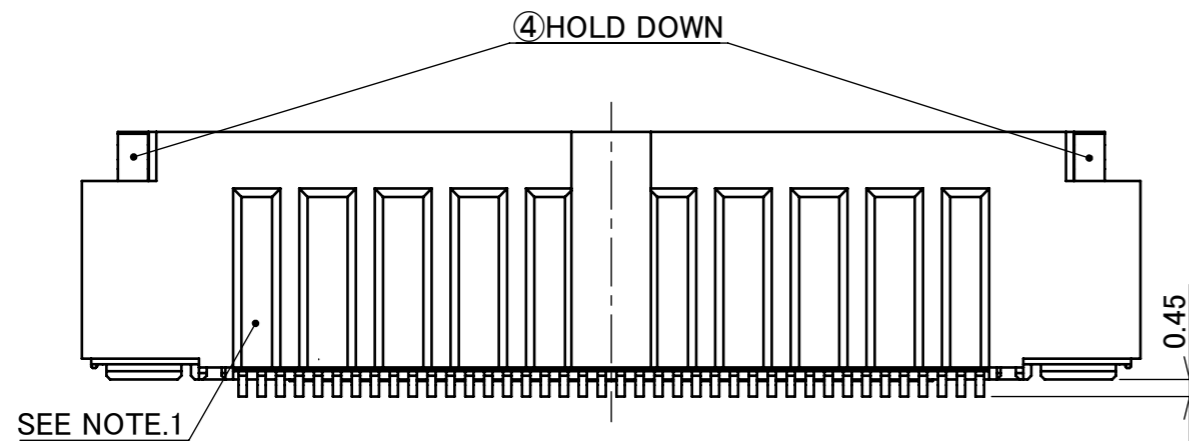

NOTES.

- DENT SHAPE SHOWN ON DRAWING IS JUST FOR REFERENCE.
DENT SHAPE AND QUANTITY MIGHT CHANGE FROM DIFFERENT PIN COUNT AND DIFFERENT TOOLING.

NO.	DISCRIPTION	MATERIAL	FINISH , REMARKS
4	HOLD DOWN	CORSON ALLOY	SOLDERING AREA : Au 0.03μm MIN. OVER Ni 1.00μm MIN.
3	CONTACT	CORSON ALLOY	CONTACT AREA AND SOLDERING AREA : Au 0.03μm MIN. OVER Ni 1.00μm MIN.
2	ACTUATOR	LCP	UL94V-0, BEIGE
1	HOUSING	LCP	UL94V-0, BEIGE

REV.	ECN	BY	DATE	APP.	ANGLE	PROJECTION	SERIES No.	TITLE	SCALE	CUSTOMER COPY	
					±2° 6 OVER 30 MAX. ±0.3		R4	EVAFLEX® 5-SE-GHT	5:1		
				6 MAX. ±0.2 30 OVER 120 MAX. ±0.5							
					GENERAL TOLERANCE.						
					DWG. T.Onishi DATE 2019/02/28						
					CHK. T.Kurachi						
					APP. H.Ikari						
REVISION RECORD											
							20899		A3	1/6	4

ITEMS	SPECIFICATION
RATING VOLTAGE	50V AC/DC (PER CONTACT PIN)
RATING AMPERAGE	0.35A AC/DC (PER CONTACT PIN) AVAILABLE FOR ALL CONTACTS 0.5A AC/DC (PER CONTACT PIN) AVAILABLE UP TO 15 CONTACTS
OPERATING TEMPERATURE	233~398K(-40°C~+125°C)
OPERATING HUMIDITY	85% MAX.(NON-CONDENSING)
CONTACT RESISTANCE	INITIAL : 60mohm MAX. / AFTER TEST : \leq 40mohm MAX.
INSULATION RESISTANCE	500Mohm MIN.
DIELECTRIC WITHSTANDING VOLTAGE	AC250V 1min
DURABILITY	50TH CYCLES
FPC/FFC MATING FORCE (INITIAL / 50TH CYCLES)	20P : 15.00 N MAX. 30P : 22.00 N MAX. 40P : 29.00 N MAX. 50P : 36.00 N MAX. 60P : 43.00 N MAX.
FPC/FFC UNMATING FORCE (INITIAL / 50TH CYCLES)	20P : 2.00 N MIN. 30P : 2.70 N MIN. 40P : 3.40 N MIN. 50P : 4.10 N MIN. 60P : 4.80 N MIN.
FPC/FFC RETENTION FORCE (INITIAL / AFTER TEST)	20P : 11.00 N MIN. 30P : 11.70 N MIN. 40P : 12.40 N MIN. 50P : 13.10 N MIN. 60P : 13.80 N MIN.
COPLANARITY	0.10 MAX.
PRODUCT SPECIFICATION	PRS-2470
TEST REPORT	TR-18020
PACKING STANDARD	PST-19019
INSTRUCTION MANUAL	HIM-18018
APPEARANCE CRITERIA No.	QLS-A***

ANGLE	$\pm 2^\circ$	6 OVER 30 MAX.	± 0.3	PROJECTION 	SERIES No. R4	CUSTOMER COPY		
6 MAX.	± 0.2	30 OVER 120 MAX.	± 0.5					
GENERAL TOLERANCE.				TITLE EVAFLEX® 5-SE-GHT	SCALE 	I-PEX		
DWG.	DATE							
CHK.								
APP.								
				DWG. No.	20899	SIZE A3	SHEET 2/6	REV. 4

PART No.	D	F	G
◆20899-020E-01	9.50	13.50	11.50
20899-030E-01	14.50	18.50	16.50
◆20899-040E-01	19.50	23.50	21.50
20899-050E-01	24.50	28.50	26.50
◆20899-060E-01	29.50	33.50	31.50

RECOMMENDED FFC LAYOUT 【NON SHIELDED TYPE】

◆MARK MEANS NOT AVAILABLE.

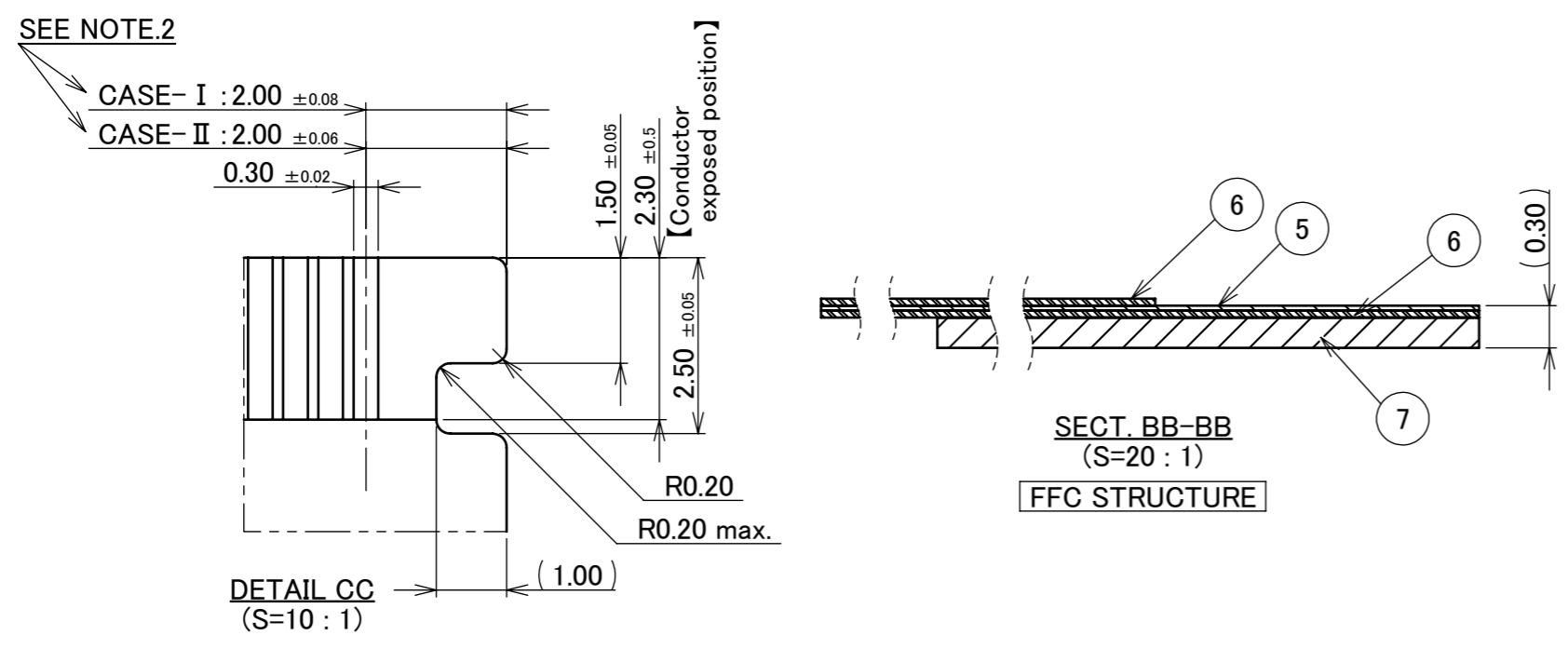
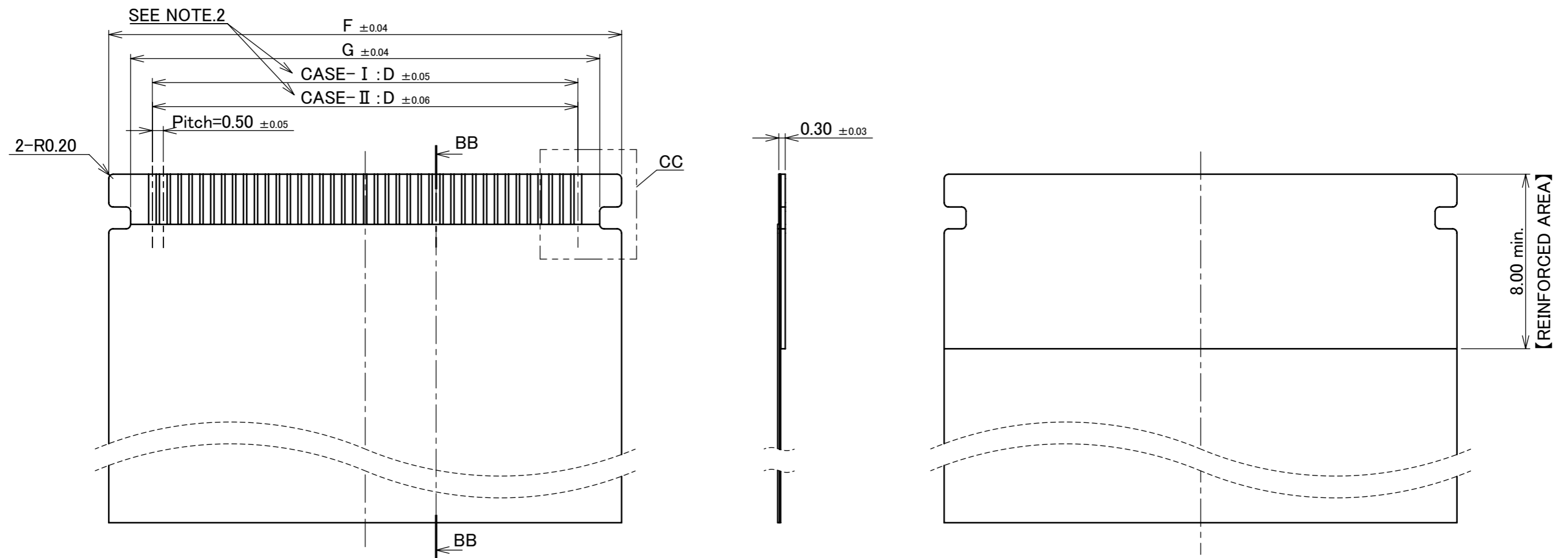

NOTES.
2. MANUFACTURE CASE- I or II
3. SELECT A MATERIAL WITH A SOFTENING TEMPERATURE OF 85°C OR HIGHER FOR THE PATTERN ADHESIVE PART OF FFC.

NO.	COMPONENTS	MATERIAL	FINISH
7	REINFORCED TAPE	ARBITRARY	
6	INSULATION FILM	ARBITRARY	
5	CONDUCTOR	COPPER ALLOY	CONTACT AREA : Au 0.05 μ m MIN. OVER Ni 0.5 μ m MIN.

ANGLE	$\pm 2^\circ$	6 OVER 30 MAX.	± 0.3	PROJECTION	SERIES No.	CUSTOMER COPY			
6 MAX.	± 0.2	30 OVER 120 MAX.	± 0.5		R4				
GENERAL TOLERANCE.				TITLE	EVAFLEX® 5-SE-GHT		SCALE		
DWG.	DATE					5:1	I-PEX		
CHK.						UNIT			
APP.				DWG. No.	20899	SIZE	SHEET	REV.	
						A3	3/6	4	

PART No.	D	F	G
◆20899-020E-01	9.50	13.50	11.50
20899-030E-01	14.50	18.50	16.50
◆20899-040E-01	19.50	23.50	21.50
20899-050E-01	24.50	28.50	26.50
◆20899-060E-01	29.50	33.50	31.50

RECOMMENDED FFC LAYOUT 【SHIELDED TYPE】

◆MARK MEANS NOT AVAILABLE.

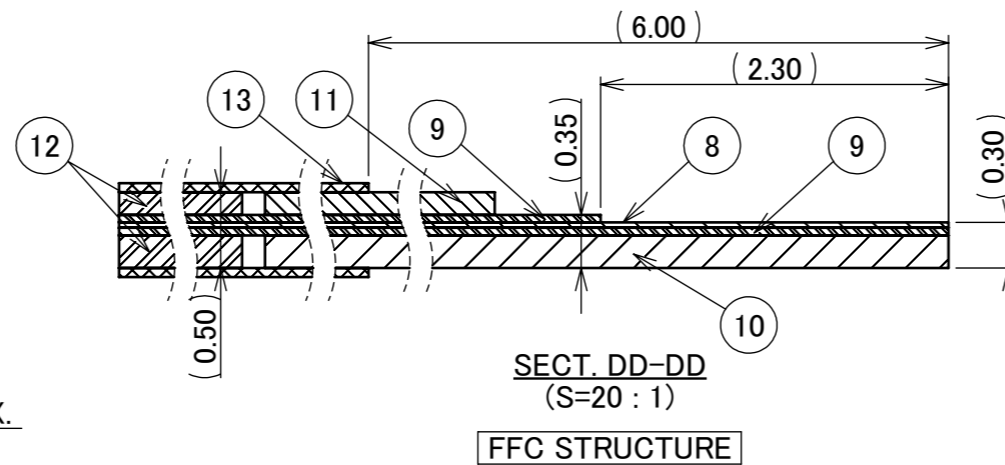
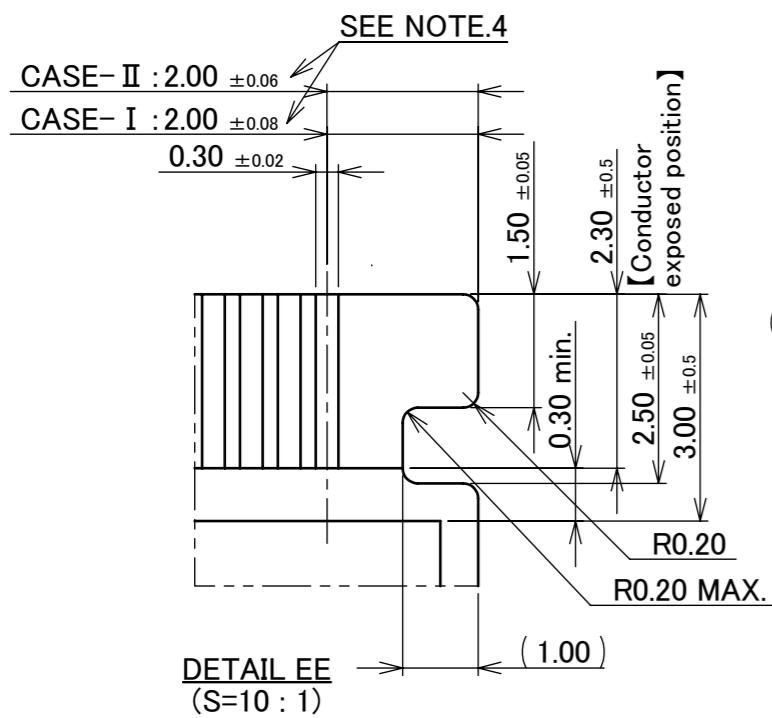
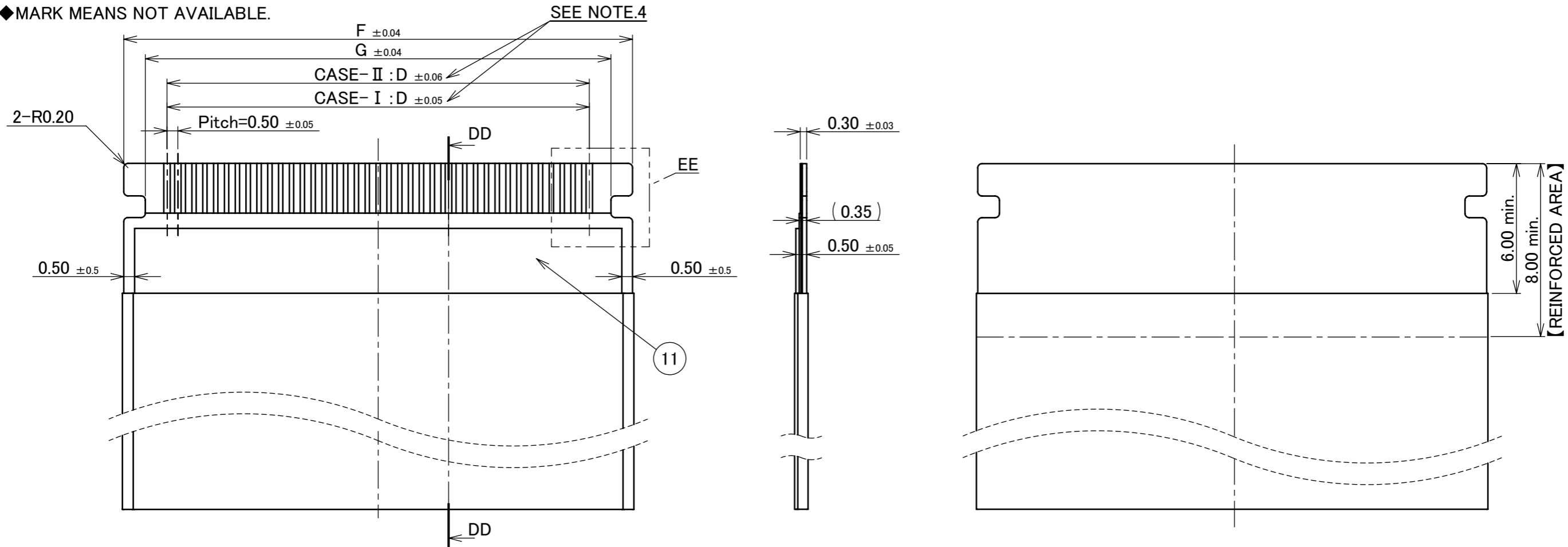

NOTES.

- 4. MANUFACTURE CASE- I or II
- 5. DIFFERENTIAL IMPEDANCE : $100 \pm 10 \Omega$
- 6. SELECT A MATERIAL WITH A SOFTENING TEMPERATURE OF 85°C OR HIGHER FOR THE PATTERN ADHESIVE PART OF FFC.

NO.	COMPONENTS	MATERIAL	FINISH
13	SHIELD TAPE	METALLIC FILM	
12	INTERLAYER	ARBITRARY	
11	GROUND PLATE	METALLIC FILM	POLISH or HALF POLISH Sn PLATING
10	REINFORCED TAPE	ARBITRARY	
9	INSULATION FILM	ARBITRARY	
8	CONDUCTOR	COPPER ALLOY	CONTACT AREA : Au $0.05 \mu\text{m}$ MIN. OVER Ni $0.5 \mu\text{m}$ MIN.

ANGLE	$\pm 2^\circ$	6 OVER 30 MAX.	± 0.3	PROJECTION	SERIES No.	CUSTOMER COPY
	6 MAX.	± 0.2	30 OVER 120 MAX.	± 0.5	R4	
GENERAL TOLERANCE.				TITLE	SCALE	
DWG.	DATE			EVAFLEX® 5-SE-GHT	5:1	
CHK.					UNIT	
APP.					mm	
				DWG. No.	20899	SIZE
						A3
						SHEET
						4/6
						REV.
						4

PART No.	B	D	H
◆20899-020E-01	15.30	9.50	10.20
20899-030E-01	20.30	14.50	15.20
◆20899-040E-01	25.30	19.50	20.20
20899-050E-01	30.30	24.50	25.20
◆20899-060E-01	35.30	29.50	30.20

◆MARK MEANS NOT AVAILABLE.

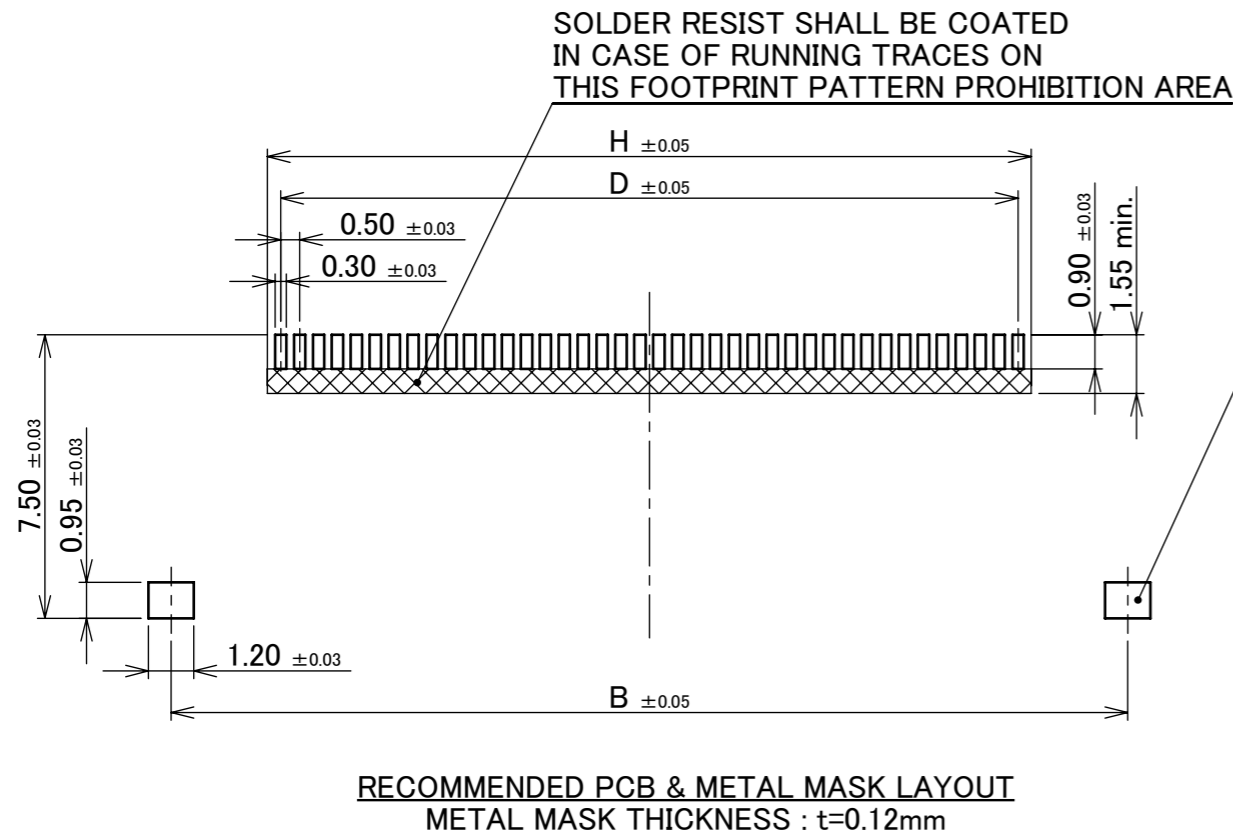

HOLD DOWN / ※GROUND PAD (※WITH SHIELDED FPC / FFC)

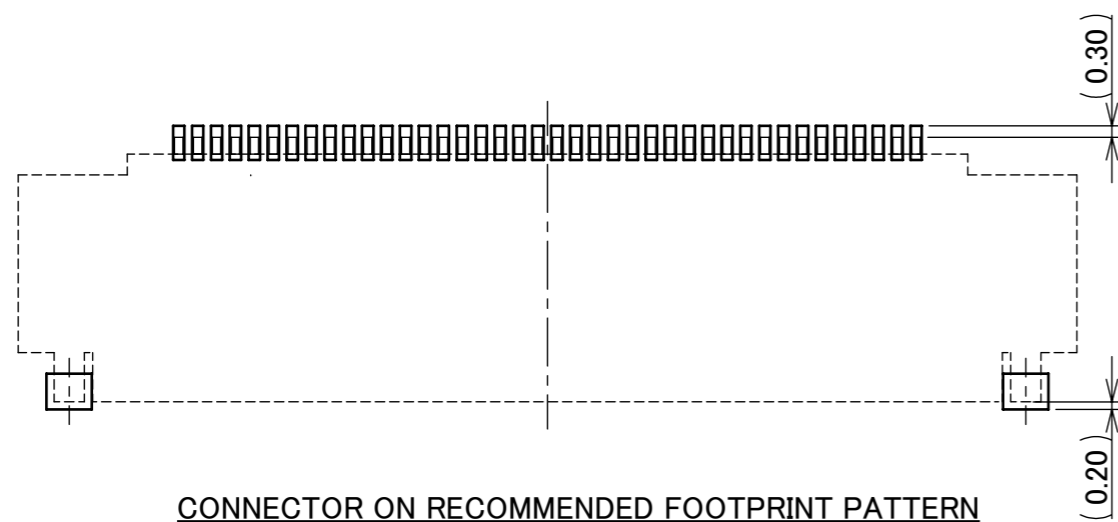
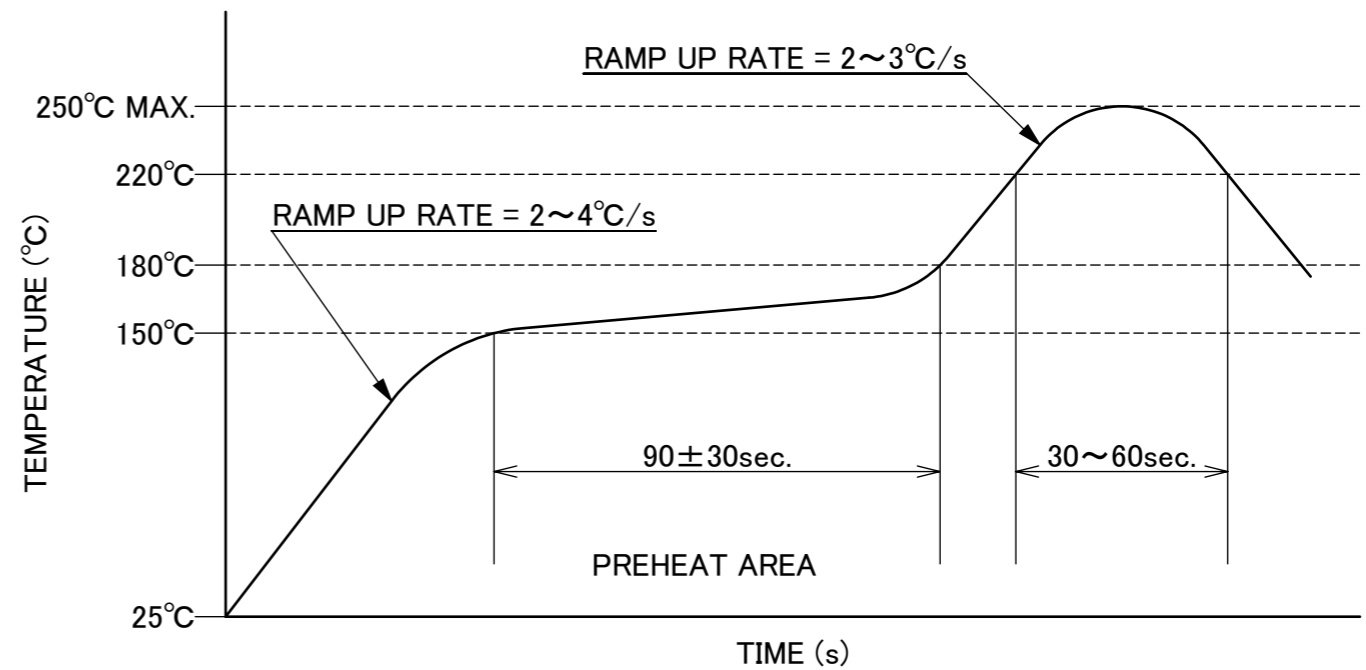

ANGLE	±2°	6 OVER 30 MAX.	±0.3	PROJECTION ⊕	SERIES No. R4	CUSTOMER COPY					
6 MAX.	±0.2	30 OVER 120 MAX.	±0.5								
GENERAL TOLERANCE.				TITLE EVAFLEX® 5-SE-GHT		SCALE 5:1	I-PEX				
DWG.	DATE					UNIT mm					
CHK.						SIZE A3				SHEET 5/6	REV. 4
APP.				DWG. No. 20899							

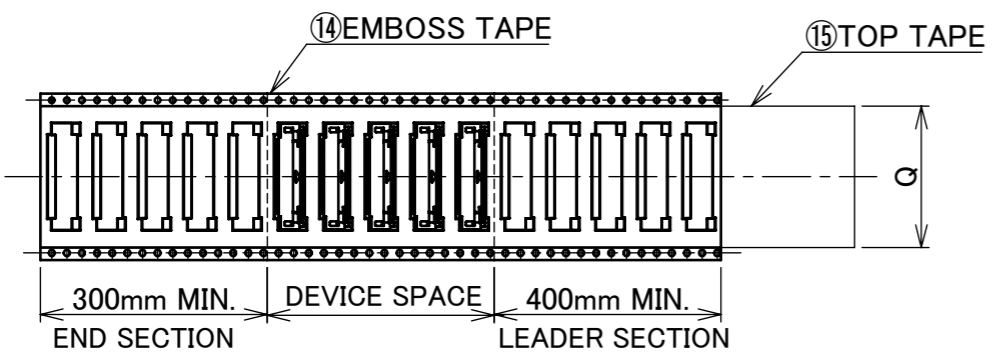

EMBOSS TAPE
(S=1/2)

PART NO.	J	K	L	M	N	P	Q	QTY. PER EMBOSS REEL (PIECES / REEL)	QTY. PER PACKING CARTON (REELS / CARTON)
◆20899-020E-01	14.20	28.40	32.00	18.20	12.00	12.20	26.00	1500 / REEL	4 / CARTON = 6000
20899-030E-01	20.20	40.40	44.00	23.20	17.00	17.20	37.50		3 / CARTON = 4500
◆20899-040E-01	20.20	40.40	44.00	28.20	22.00	22.20	37.50		
20899-050E-01	20.20	40.40	44.00	33.20	27.00	27.20	37.50		
◆20899-060E-01	26.20	52.40	56.00	38.20	32.00	32.20	49.00		

◆ MARK MEANS NOT AVAILABLE.

NOTES.

7. TAPING SPECIFICATION FOLLOWS JIS C 0806 (IEC 60286-3).
8. MAKE EMPTY SECTION OF LEADER AND END ON EACH END OF THE TAPE.
9. TOP TAPE SHALL NOT STICK OUT FROM EMBOSS TAPE.
10. TOP TAPE SHALL NOT COVER FEED HOLE.
11. DRAFT ANGLE OF EMBOSS TAPE 3° MAX. AND DON'T BECOME A REVERSE SLOPE.

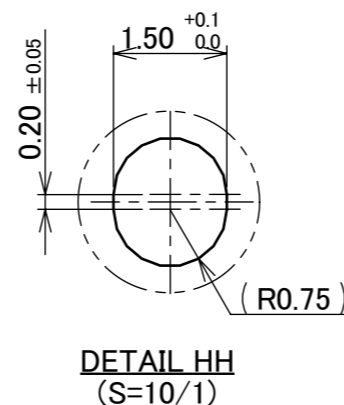
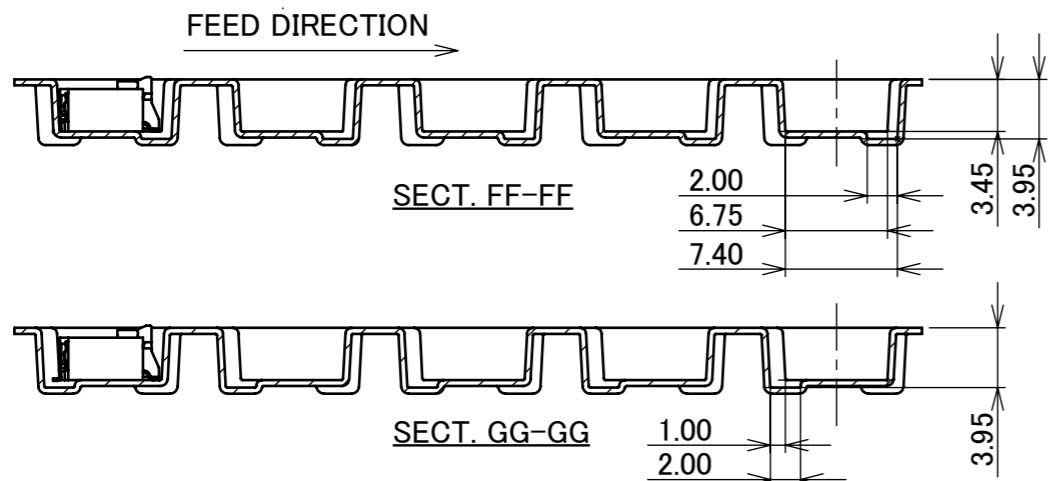
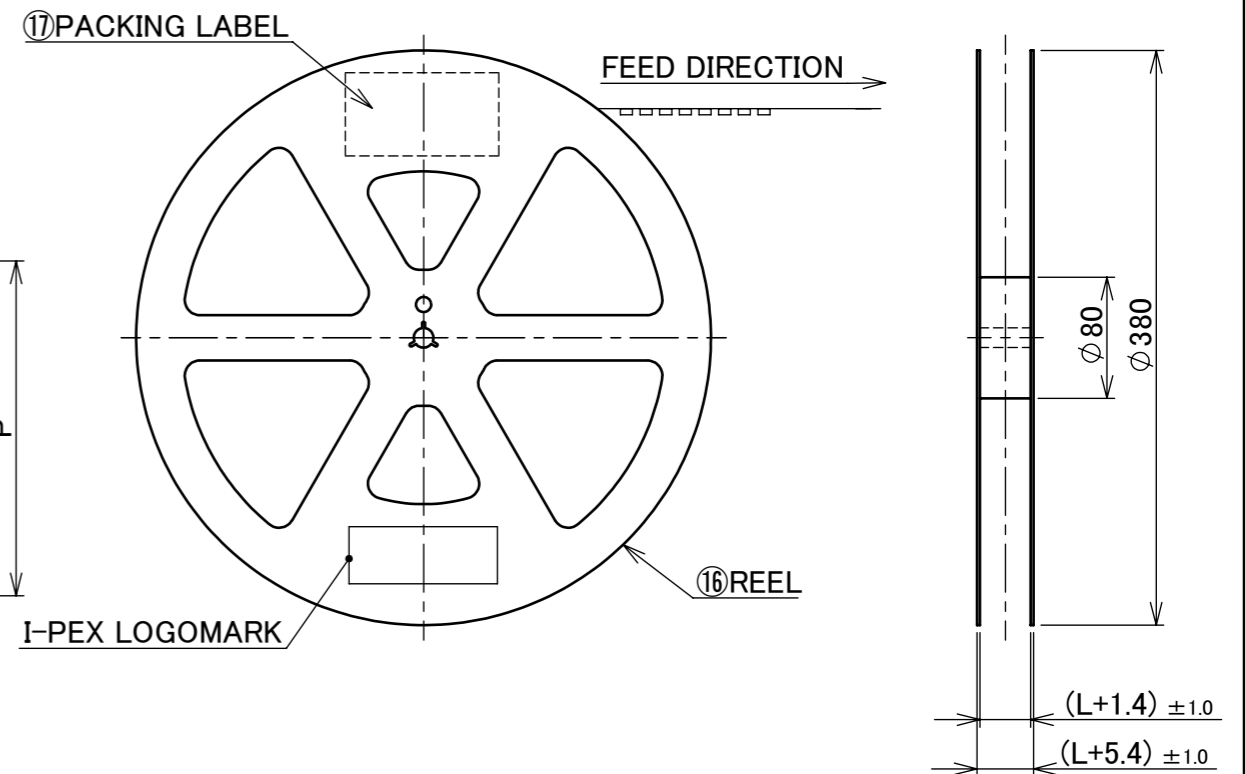
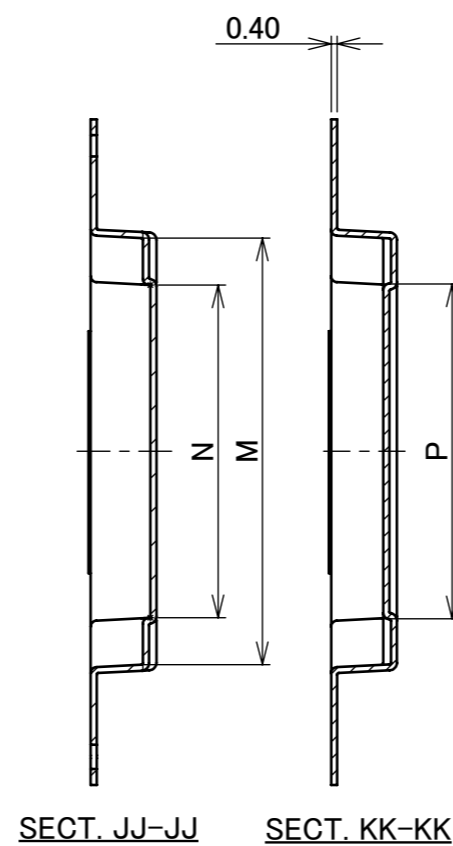
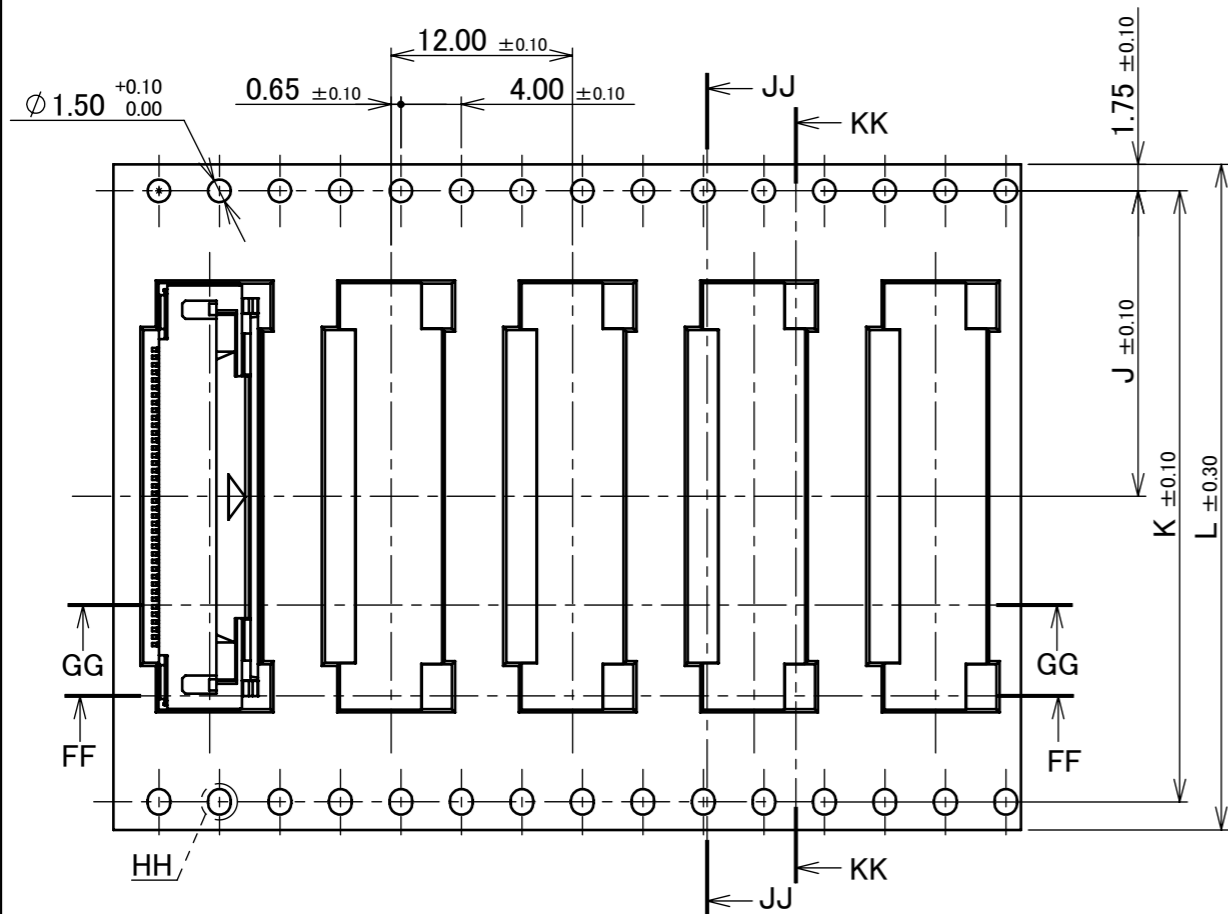

NO.	DISCRIPTION	MATERIAL	FINISH , REMARKS
17	PACKING LABEL	-	-
16	REEL	PS	WHITE
15	TOP TAPE	PET t=0.062 TRANSPARENCY	ANTI-STATIC TYPE HEAT WELDING TYPE
14	EMBOSS TAPE	PS t=0.4 TRANSPARENCY	ANTI-STATIC TYPE

ANGLE	±2°	6 OVER 30 MAX.	±0.3	PROJECTION	SERIES No.	CUSTOMER COPY
6 MAX.	±0.2	30 OVER 120 MAX.	±0.5		R4	
GENERAL TOLERANCE.				TITLE	EVAFLEX® 5-SE-GHT	
DWG.	DATE			SCALE		I-PEX
CHK.				UNIT		
APP.				mm		
				DWG. No.	20899	SIZE SHEET REV.
						A3 6/6 4