

Recommended P/N 20453-2**T-03(20P/30P/40P) 20453-250T-03S(50P)

PART NO.	Pos.	A	B	C	D	E	F	G	H
20453-#20T-*1	20	9.50	10.30	12.56	16.00	16.15	13.00	17.55	14.45
20453-#30T-*1	30	14.50	15.30	17.56	21.00	21.15	18.00	22.55	19.45
20453-#40T-*1	40	19.50	20.30	22.56	26.00	26.15	23.00	27.55	24.45
20453-#50T-*1S	50	24.50	25.30	27.56	31.00	31.15	28.00	32.55	29.45

WITH PULL-BAR & PULL-TAPE



P/N:20453-#**T-***
 NOTHING : HOUSING ASS'Y P/N 20454-##*T
 S : HOUSING ASS'Y P/N 20454-##*T-01
 1 : WITH PULL-BAR P/N 2576-0**-**
 2 : WITHOUT PULL-BAR
 3 : WITH INSULATION COAT PULL-BAR P/N 2576-1**-**
 0 : WITH DATUM MARK P/N 2574-0**#
 1 : WITHOUT DATUM MARK P/N 2574-1**#
 SEE TABLE.1

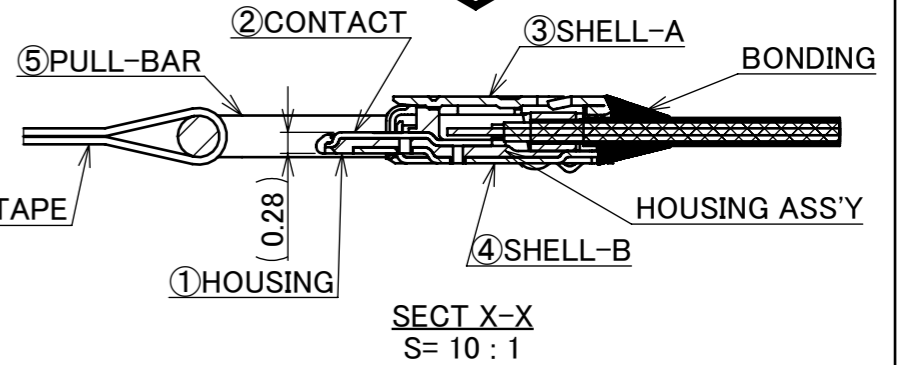
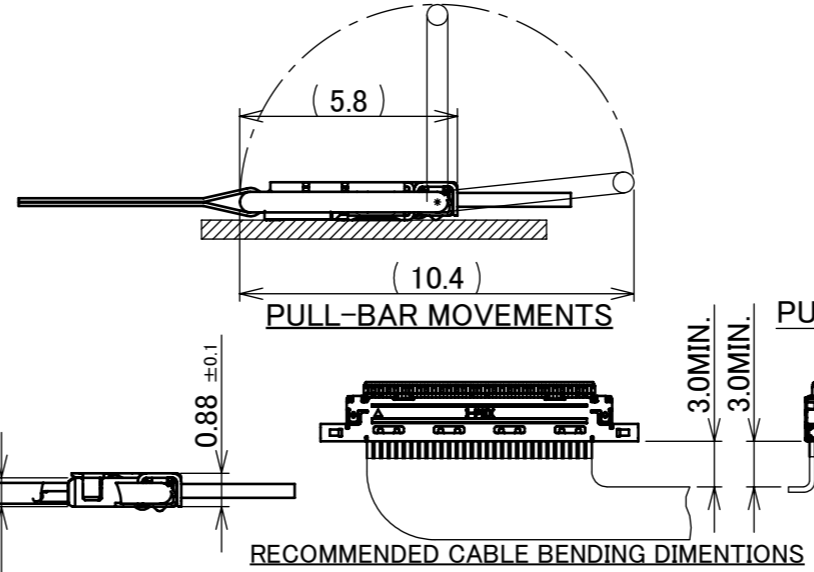
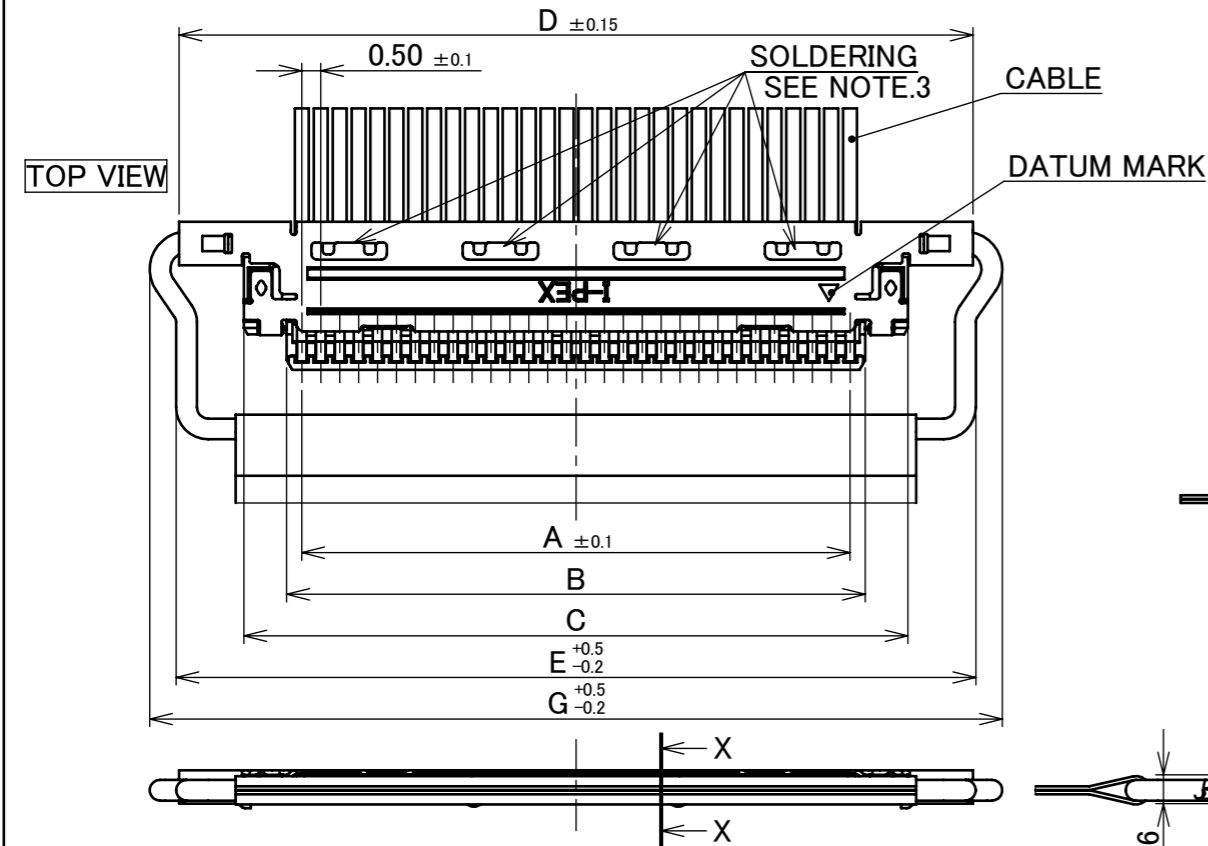
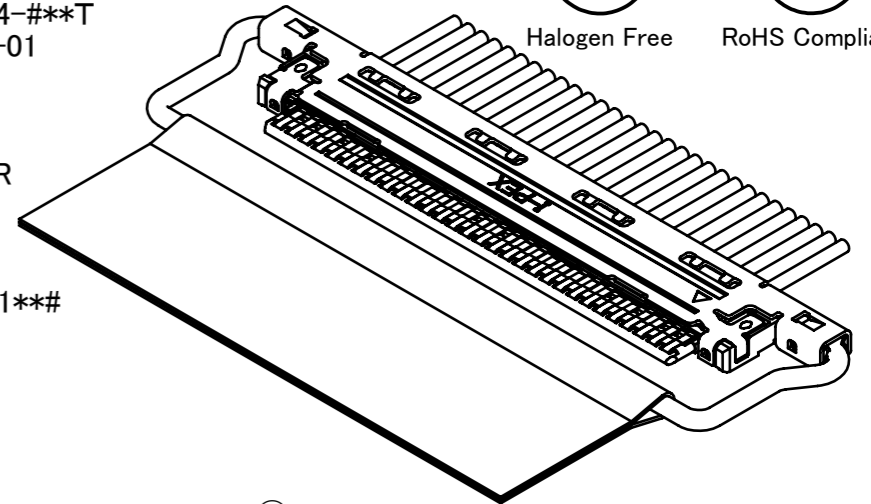

CABLE ASS'Y PART NO.	HOUSING ASS'Y PART NO.	SHELL-A PART NO.	PULL-BAR PART NO.
20453-0**T-*1*	20454-0**T-**	2574-***	2576-0**-**
20453-2**T-*1*	20454-2**T-**	2574-***2	2576-0**-**

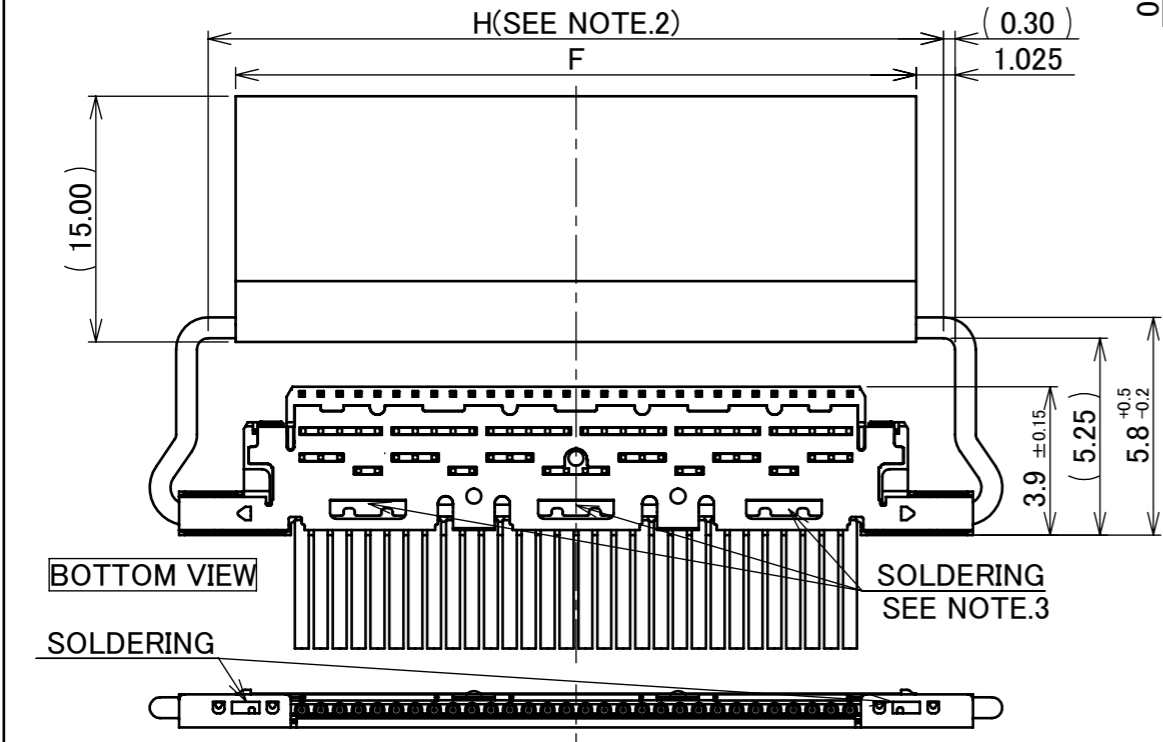

NOTES.
 1.RECOMMENDED PULL-TAPE
 PULL-TAPE : TERAOKA's INSULATION TAPE No.650S(#50) t=0.08
 2.PULL-TAPE CAN BE PUT WITHIN THE RANGE OF "H"(STRAIGHT AREA)
 3.SOLDERING IS ONLY A CASE WITH GND-BAR

PATENT REGISTERED

TABLE.1

PART NO.	CONTACT FINISH	SHELL-A FINISH	SHELL-B FINISH
20453-0**T-***	CONTACT AREA : Au 0.1 μm MIN. OVER Ni 1.00 μm MIN. SOLDERING AREA : Au 0.05 μm MIN. OVER Ni 1.00 μm MIN.	TOP SIDE : Au 0.05 μm MIN. OVER Ni 1.00 μm MIN. BOTTOM SIDE : Au 0.015 μm MIN. OVER Ni 1.00 μm MIN.	TOP SIDE : Au 0.015 μm MIN. OVER Ni 1.00 μm MIN. BOTTOM SIDE : Au 0.05 μm MIN. OVER Ni 1.00 μm MIN.
20453-2**T-***	CONTACT AREA : Au 0.1 μm MIN. OVER Ni 1.00 μm MIN. SOLDERING AREA : Au 0.05 μm MIN. OVER Ni 1.00 μm MIN.	TOP SIDE : Au 0.03 μm MIN. OVER Ni 1.00 μm MIN. BOTTOM SIDE : Ni 1.00 μm MIN.(THERE IS THE POSSIBILITY THAT Au ATTACHES RANDOMLY)	TOP SIDE : Ni 1.00 μm MIN.(THERE IS THE POSSIBILITY THAT Au ATTACHES RANDOMLY) BOTTOM SIDE : Au 0.03 μm MIN. OVER Ni 1.00 μm MIN.

NO.	DISCRIPTION	MATERIAL	FINISH , REMARKS
5	PULL-BAR	SUS	
4	SHELL-B	PHOSPHOR BRONZE	SEE ABOVE TABLE.1
3	SHELL-A	PHOSPHOR BRONZE	SEE ABOVE TABLE.1
2	CONTACT	PHOSPHOR BRONZE	SEE ABOVE TABLE.1
1	HOUSING	LCP	UL94V-0, BLACK

33	Z211561	R.M	Dec./21/'21	H.I	ANGLE	±2°	6 OVER 30 MAX.	±0.3	PROJECTION	SERIES No. R11R3R0	CUSTOMER COPY					
32	Z211259	R.M	Oct./18/'21	H.I	6 MAX.	±0.2	30 OVER 120 MAX.	±0.5								
31	Z210160	R.M	Feb./17/'21	H.I	GENERAL TOLERANCE.			TITLE CABLINER [®] -VS PLUG FOR CABLE ASS'Y	SCALE 5:1	UNIT mm	SHEET 1/6					
30	Z201153	T.Ono	Nov./05/'20	H.I	DWG.	DATE						2007/09/27				
29	Z191177	R.M	Sept./16/'19	H.I	H.Ikari		CHK.									
28	Z190010	Y.M	Jan./07/'19	H.I												
REV.	ECN	BY	DATE	APP.	APP.	E.Kawabe		2007/09/27	DWG. No.	20453	SIZE	A3	SHEET	1/6	REV.	33

WITHOUT PULL-BAR

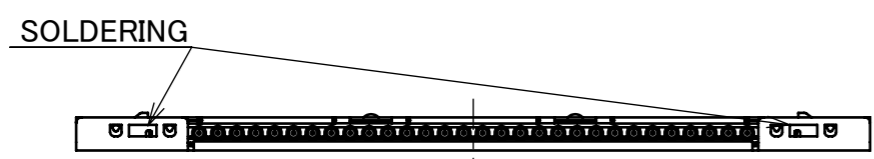
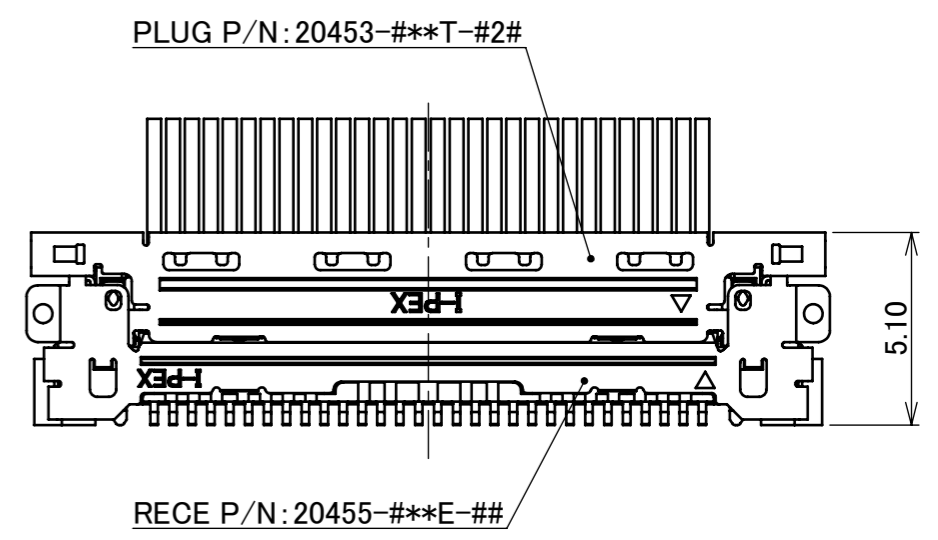
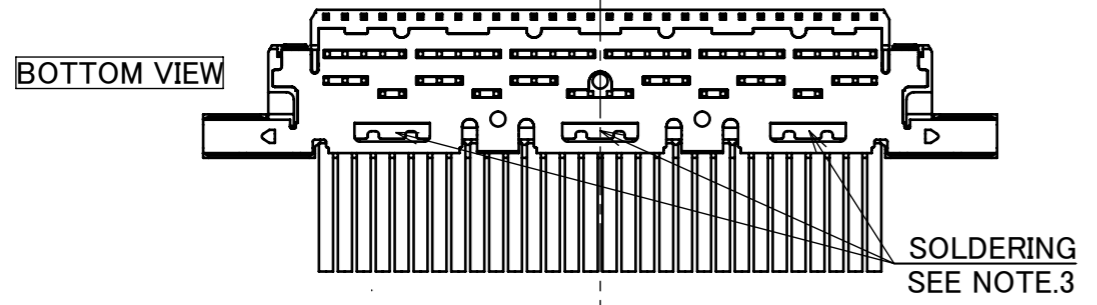
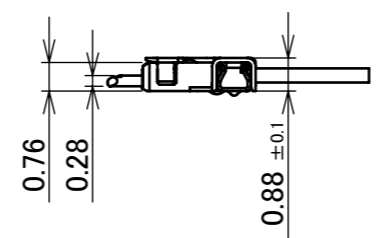
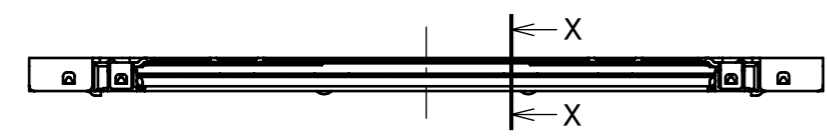
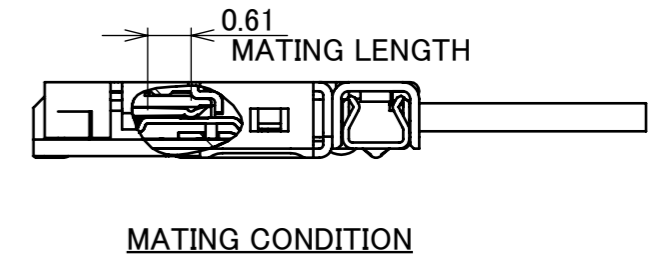
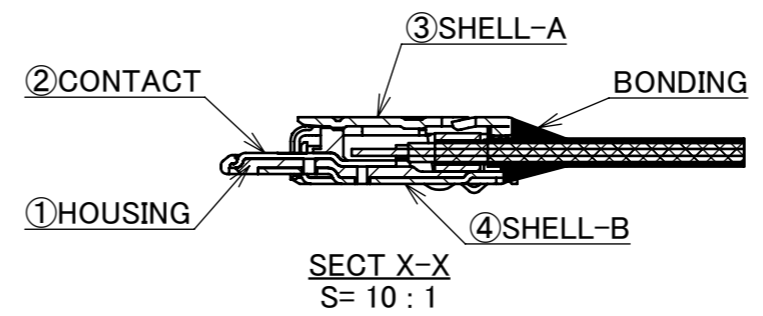
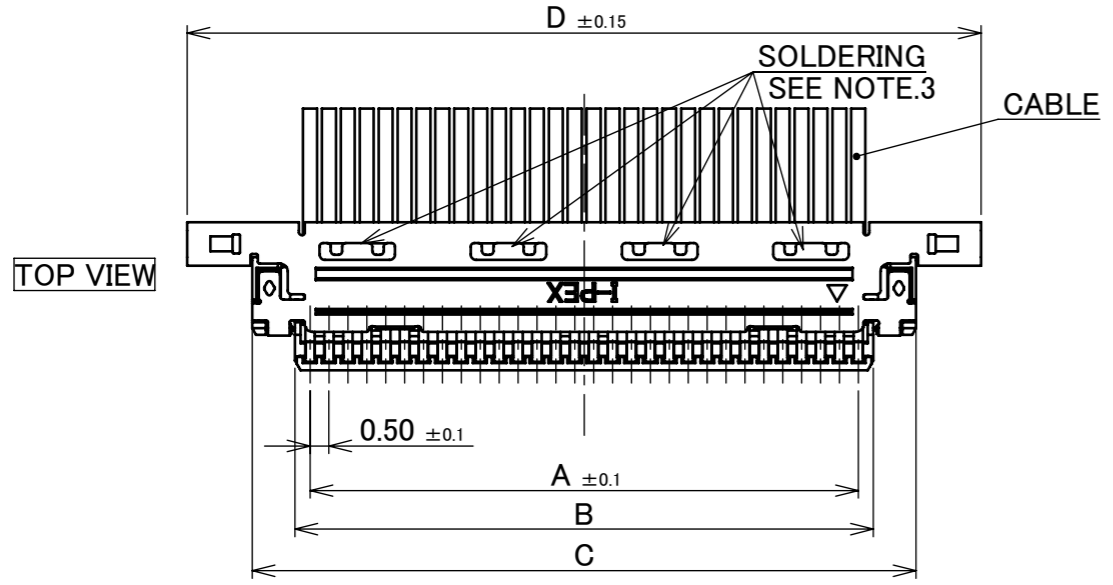
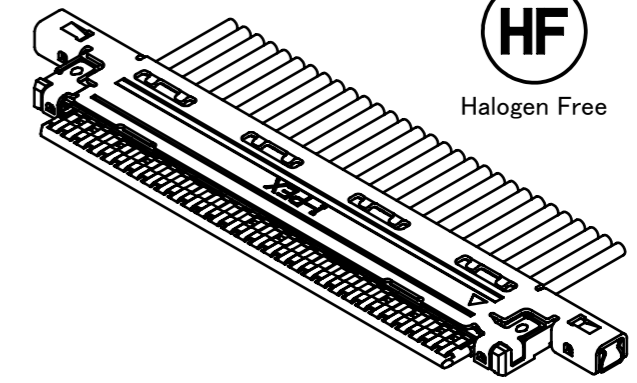

PATENT REGISTERED

PART NO.			
CABLE ASS'Y PART NO.	HOUSING ASS'Y PART NO.	SHELL-A PART NO.	PULL-BAR PART NO.
20453-0**T-*2*	20454-0**T-**	2574-***	-
20453-2**T-*2*	20454-2**T-**	2574-***2	-

ANGLE	±2°	6 OVER 30 MAX.	±0.3	PROJECTION ⊕	SERIES No. R11R3R0	CUSTOMER COPY		
6 MAX.	±0.2	30 OVER 120 MAX.	±0.5					
GENERAL TOLERANCE.				TITLE CABLIN [®] -VS PLUG FOR CABLE ASS'Y	SCALE 5:1 UNIT mm	I-PEX		
DWG.	DATE							
CHK.								
APP.								
				DWG. No.	20453	SIZE A3	SHEET 2/6	REV. 33

WITH INSULATION COAT PULL-BAR



Halogen Free



RoHS Compliant

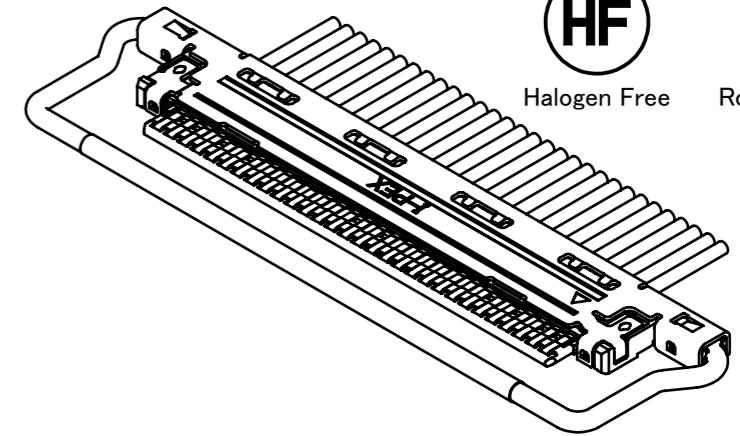

TOP VIEW

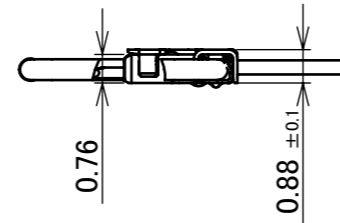
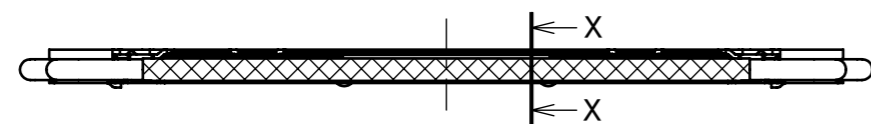
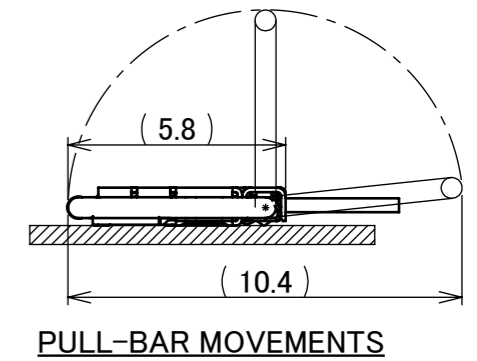
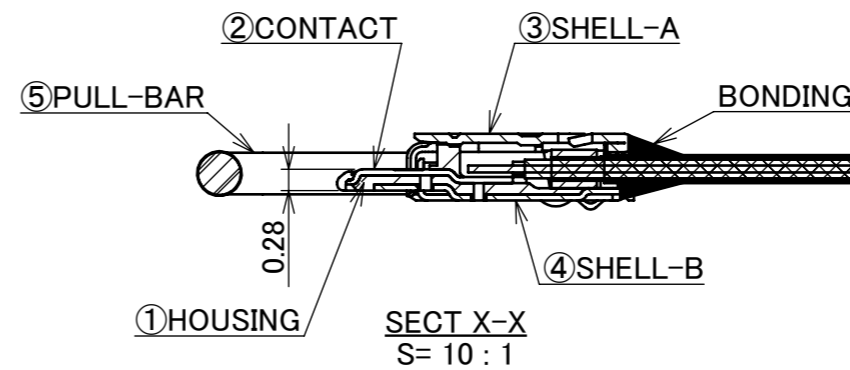
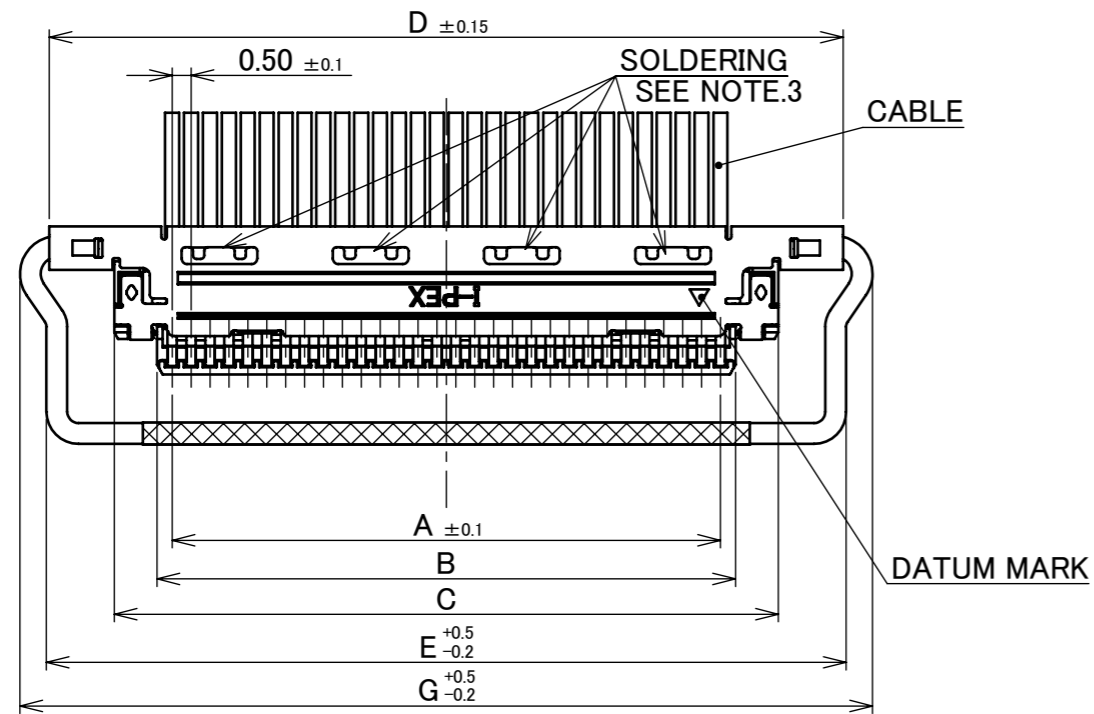

BOTTOM VIEW

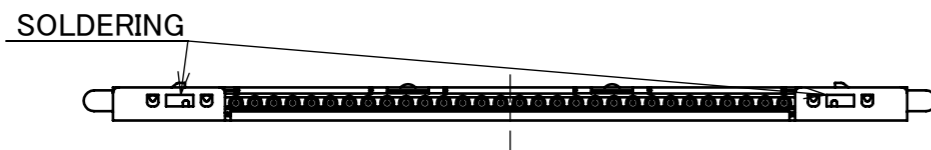
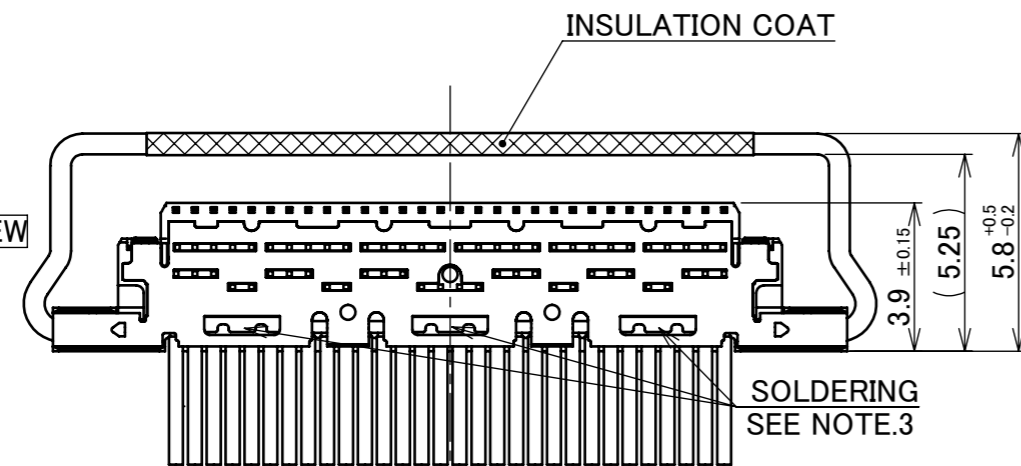

PART NO.

CABLE ASS'Y PART NO.	HOUSING ASS'Y PART NO.	SHELL-A PART NO.	PULL-BAR PART NO.
20453-0**T-*3*	20454-0**T-**	2574-***	2576-1**-**
20453-2**T-*3*	20454-2**T-**	2574-***2	2576-1**-**

ANGLE	±2°	6 OVER 30 MAX.	±0.3	PROJECTION ⊕	SERIES No. R11R3R0	CUSTOMER COPY		
	6 MAX.	±0.2	30 OVER 120 MAX.					
GENERAL TOLERANCE.				TITLE CABLIN [®] -VS PLUG FOR CABLE ASS'Y		SCALE 5:1	I-PEX	
DWG.	DATE				UNIT mm			
CHK.								
APP.				DWG. No.	20453	SIZE A3	SHEET 3/6	REV. 33

PATENT REGISTERED

ITEMS	SPECIFICATION
APPLICABLE CABLE	MICRO COAX : AWG# 44, 42, 40, 38, 36 DISCRETE : AWG# 36, 34, 32 TWINCOAX : AWG# 40
RATING VOLTAGE	100V AC (PER CONTACT)
RATING AMPERAGE (FOR CONTACT)	0.1A AC/DC [AWG#44] PER CONTACT/UP TO 50 CONTACTS 0.24A AC/DC [AWG#42] PER CONTACT/UP TO 50 CONTACTS 0.3A AC/DC [AWG#40] PER CONTACT/UP TO 50 CONTACTS 0.5A AC/DC [AWG#38] PER CONTACT/UP TO 14 CONTACTS 0.8A AC/DC [AWG#36] PER CONTACT/UP TO 10 CONTACTS 1.0A AC/DC [AWG#34] PER CONTACT/UP TO 6 CONTACTS 1.0A AC/DC [AWG#32] PER CONTACT/UP TO 6 CONTACTS TESTING BY A REAL MACHINE IS RECOMMENDED BECAUSE TEMPERATURE RISE MAY AFFECTED BY ACTUAL SITUATION.
OPERATING TEMPERATURE	233~358K(-40°C~+85°C)
OPERATING HUMIDITY	85% R.H. MAX.(NON-CONDENSING)
CONTACT RESISTANCE	INITIAL : 140mohm MAX.(AWG#32) / AFTER TEST : \triangle 40mohm MAX. 180mohm MAX.(AWG#34) 275mohm MAX.(AWG#36) 360mohm MAX.(AWG#38) 600mohm MAX.(AWG#40) 700mohm MAX.(AWG#42) 1080mohm MAX.(AWG#44)
GROUND SHELL RESISTANCE	INITIAL : 50mohm MAX. / AFTER TEST : \triangle 40mohm MAX.
INSULATION RESISTANCE	INITIAL : 1000Mohm MIN. / AFTER TEST : 500Mohm MIN.
DIELECTRIC WITHSTANDING VOLTAGE	AC250V 1min
DURABILITY	30 CYCLES
MATING FORCE (INITIAL / AFTER TEST)	20P : 9.45N MAX. 30P : 12.15N MAX. 40P : 16.20N MAX. 50P : 20.25N MAX.
UNMATING FORCE (INITIAL / AFTER TEST)	20P : 2.0N MIN. 30P : 3.0N MIN. 40P : 4.0N MIN. 50P : 5.0N MIN.
CABLE RETENTION FORCE	20P : 9.80N MIN. 30P : 14.70N MIN. 40P : 19.60N MIN. 50P : 24.50N MIN.
PRODUCT SPECIFICATION	PRS-1427
TEST REPORT	TR-08047 (20453-0**T-###) / TR-13084 (20453-2**T-###)
INSTRUCTION MANUAL	HIM-08004
ASSEMBLY MANUAL	ASM-08003
APPEARANCE CRITERIA No.	QLS-A***

ANGLE	$\pm 2^\circ$	6 OVER 30 MAX.	± 0.3	PROJECTION 	SERIES No. R11R3R0	CUSTOMER COPY		
6 MAX.	± 0.2	30 OVER 120 MAX.	± 0.5					
GENERAL TOLERANCE.				TITLE CABLIN [®] -VS PLUG FOR CABLE ASS'Y	SCALE 5:1 UNIT mm			
DWG.	DATE							
CHK.								
APP.								
				DWG. No.	20453	SIZE A3	SHEET 4/6	REV. 33

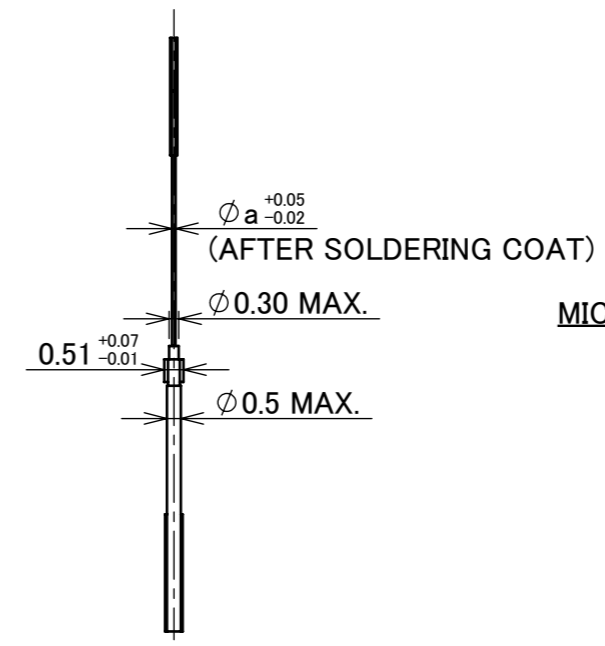
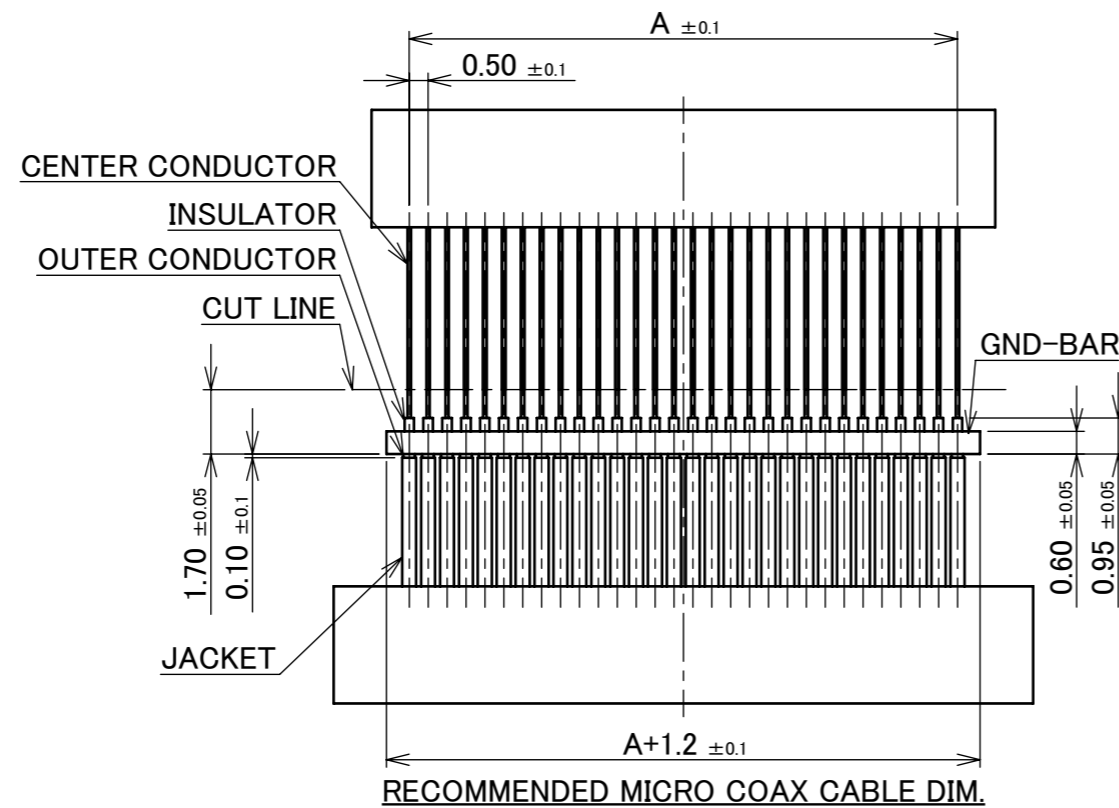

MICRO COAX CABLE DIMENSION

	a
#36	0.15
#38	0.12
#40	0.09
#42	0.075
#44	0.063

MICRO COAX CABLE AWG#**

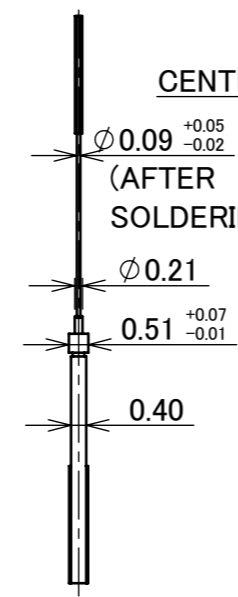
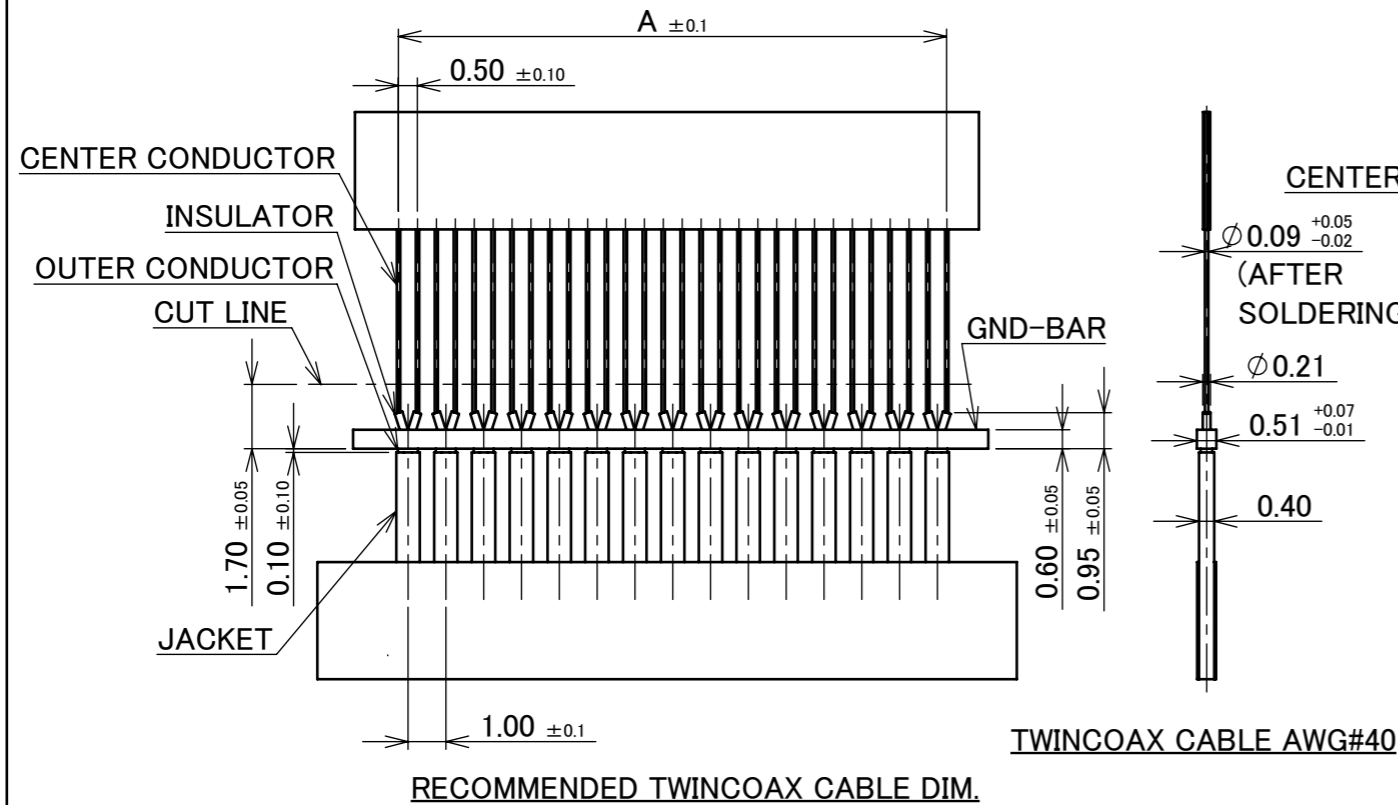

TWINCOAX CABLE AWG#40

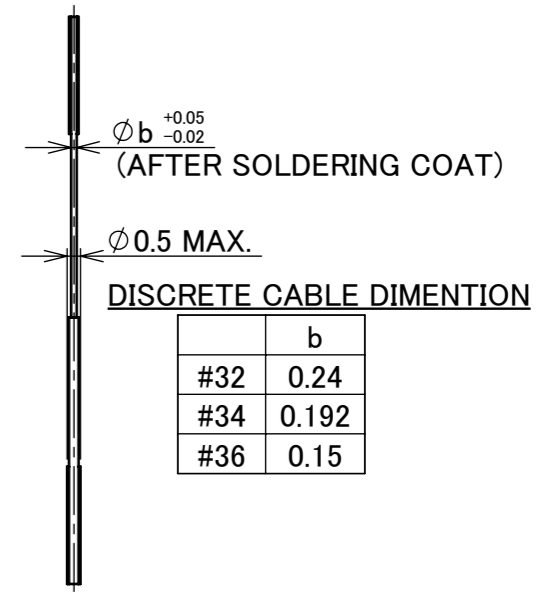
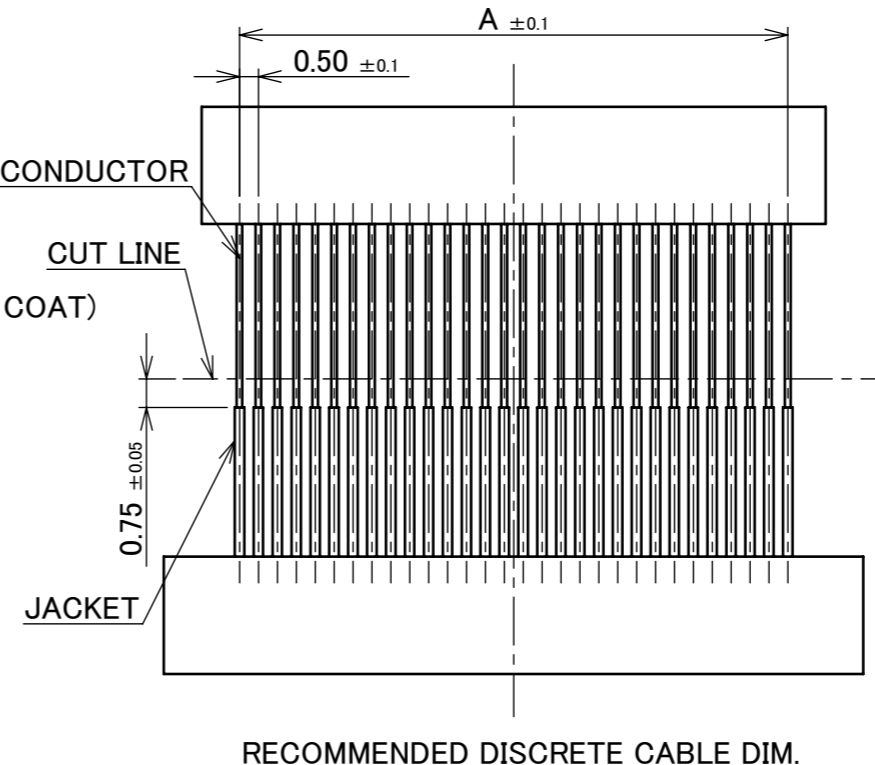

DISCRETE CABLE DIMENTION

	b
#32	0.24
#34	0.192
#36	0.15

DISCRETE CABLE AWG#**

ANGLE	$\pm 2^\circ$	6 OVER 30 MAX.	± 0.3	PROJECTION 	SERIES No. R11R3R0	CUSTOMER COPY		
	6 MAX.	± 0.2	30 OVER 120 MAX.					
GENERAL TOLERANCE.				TITLE CABLIN [®] -VS PLUG FOR CABLE ASS'Y	SCALE 5:1 UNIT mm			
DWG.	DATE							
CHK.								
APP.								
				DWG. No.	20453	SIZE A3	SHEET 5/6	REV. 33

THE EXTERNAL APPEARANCE

20P

TOP VIEW

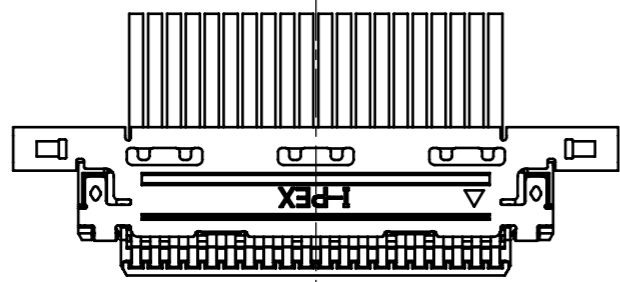

BOTTOM VIEW

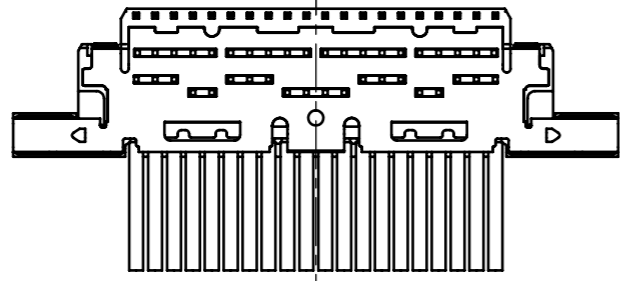

40P

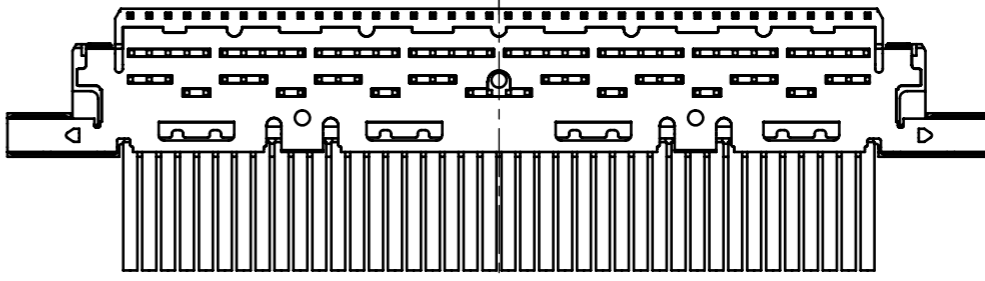
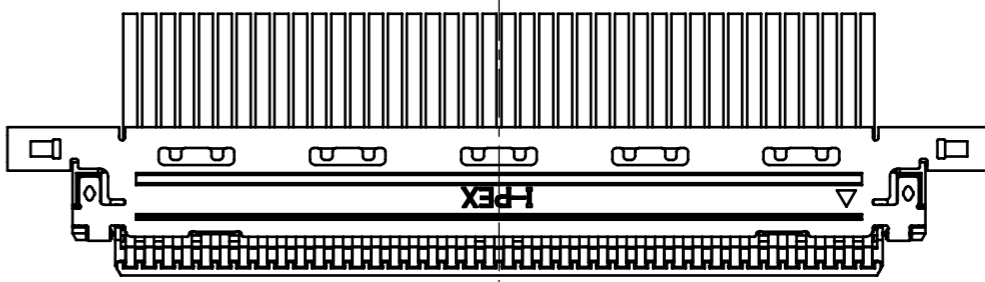

30P

TOP VIEW

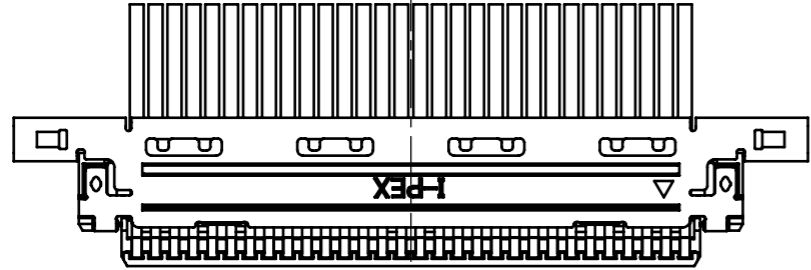

BOTTOM VIEW

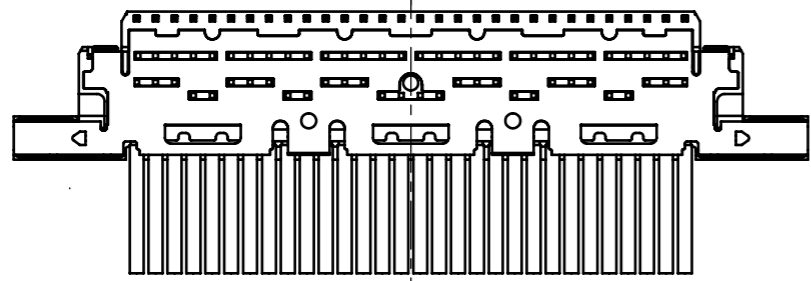

50P

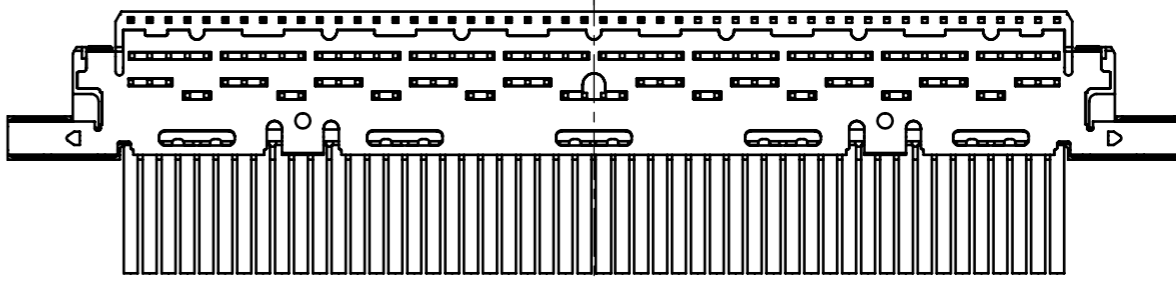
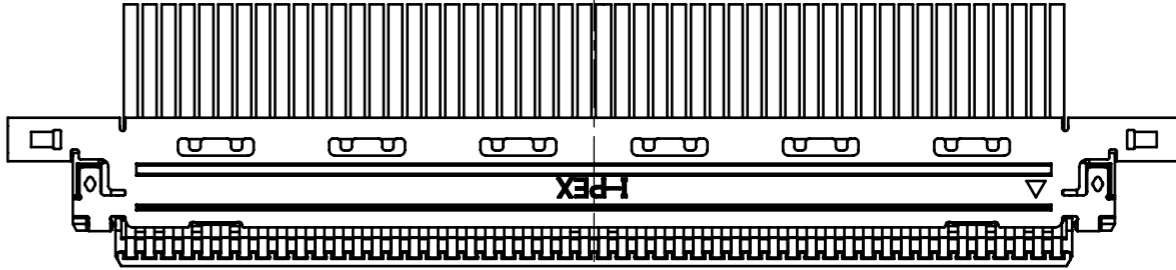

ANGLE	$\pm 2^\circ$	6 OVER 30 MAX.	± 0.3	PROJECTION 	SERIES No. R11R3R0	CUSTOMER COPY		
6 MAX.	± 0.2	30 OVER 120 MAX.	± 0.5					
GENERAL TOLERANCE.				TITLE CABLIN [®] -VS PLUG FOR CABLE ASS'Y	SCALE 5:1 UNIT mm	I-PEX		
DWG.	DATE							
CHK.								
APP.								
				DWG. No.	20453	SIZE A3	SHEET 6/6	REV. 33