

Recommended P/N 20849-0**E-01

PART NO.	Pos.	A	B	C	D
20849-020E-0#	20	11.30	9.50	14.33	15.10
20849-030E-0#	30	16.30	14.50	19.33	20.10
20849-040E-0#	40	21.30	19.50	24.33	25.10

P/N : 20849- 0 ** E- 0 #
SEE TABLE 1
POS.

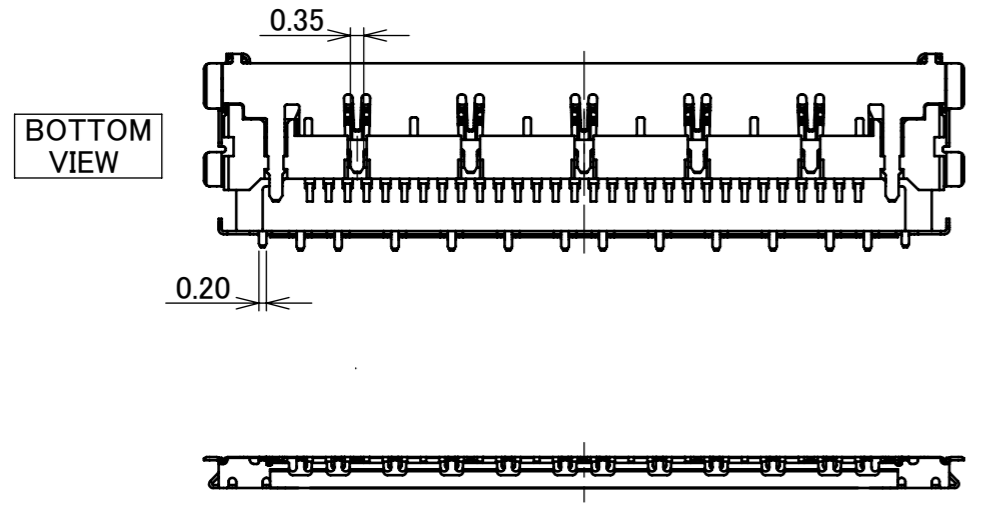
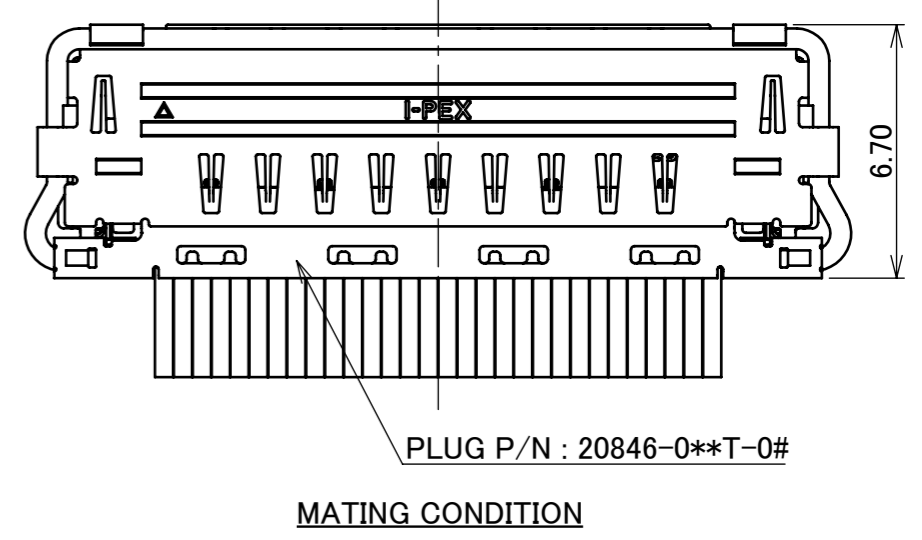
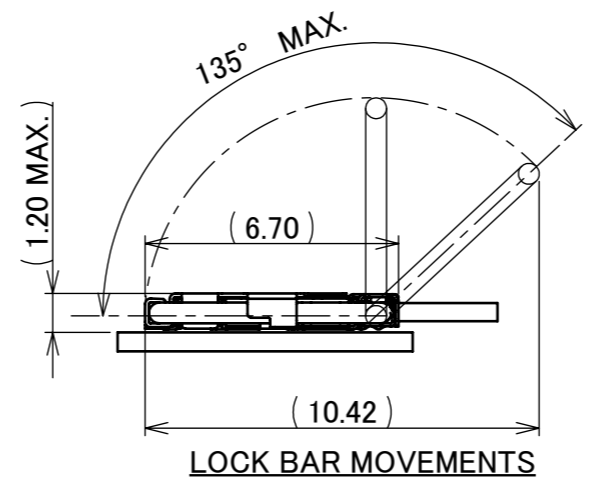
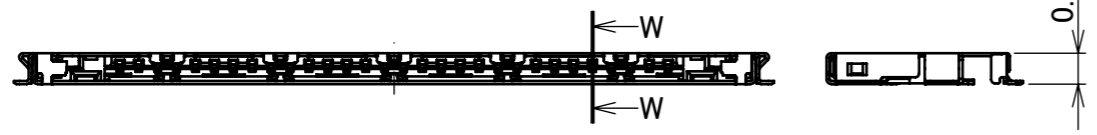
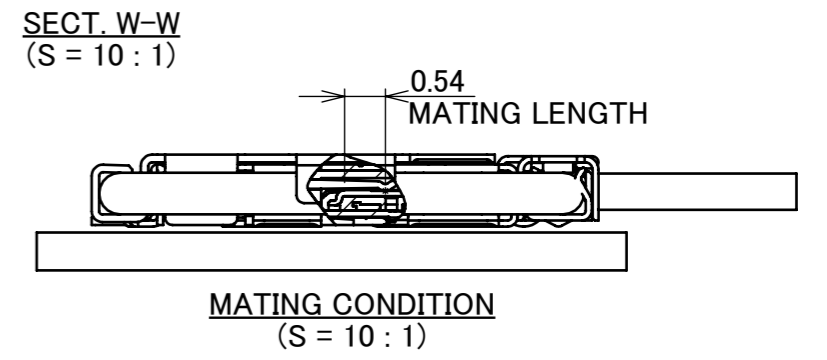
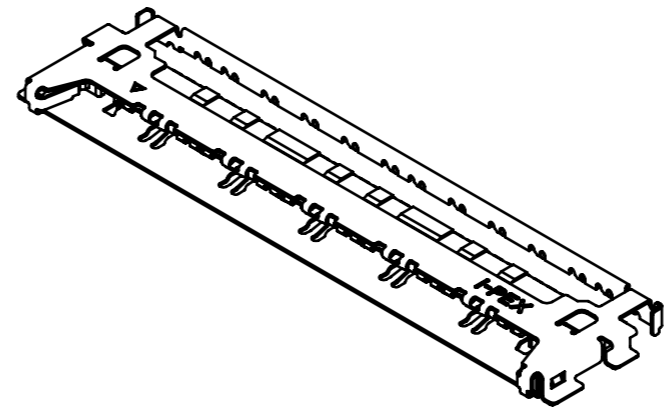
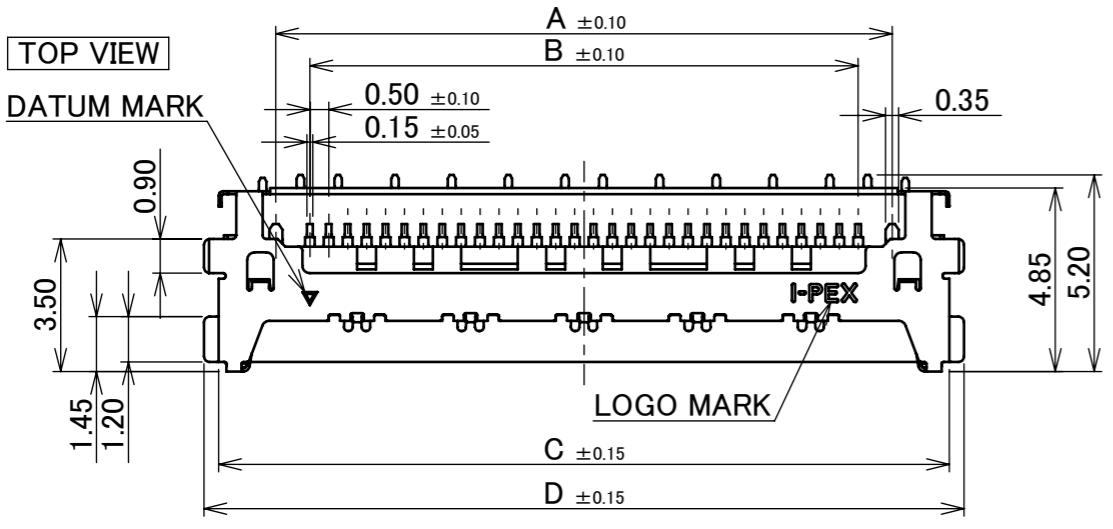
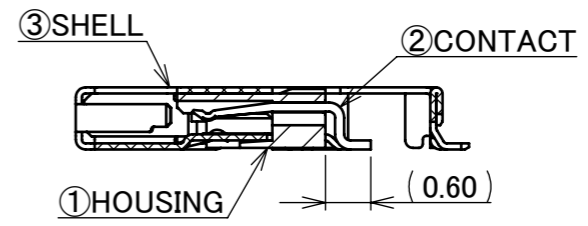

TABLE.1

PART NO.	CONTACT FINISH	SHELL FINISH
20849-0**E-01	CONTACT & SOLDERING AREA : Au 0.03 μm MIN. OVER Ni 1.00 μm MIN.	ALL OVER Ni 1.00 μm MIN. SOLDERING AREA : Au 0.02 μm MIN.
20849-0**E-02	CONTACT AREA : Au 0.38 μm MIN. OVER Ni 1.27 μm MIN. SOLDERING AREA : Au 0.03 μm MIN. OVER Ni 1.00 μm MIN.	

NO.	DISCRIPTION	MATERIAL	FINISH , REMARKS
3	SHELL	PHOSPHOR BRONZE	SEE TABLE 1
2	CONTACT	PHOSPHOR BRONZE	SEE TABLE 1
1	HOUSING	LCP	UL94V-0, BLACK

REV.	ECN	BY	DATE	APP.	APP.	PROJECTION	SERIES No.	TITLE	SCALE	CUSTOMER COPY
9	Z230311	Y.I	Mar./17/'23	M.T	ANGLE ±2°		R2	CABLIN® -VS II RECE. ASS'Y	5:1	I-PEX
8	Z220254	K.W	Mar./09/'22	H.I	6 MAX. ±0.2				UNIT	
7	Z220121	M.N	Feb./04/'22	H.I	6 OVER 30 MAX. ±0.3	mm	SIZE	A3	SHEET	REV.
6	Z201143	M.N	Nov./04/'20	H.I	30 OVER 120 MAX. ±0.5	DATE	20849			
5	Z200862	M.N	Aug./21/'20	H.I	GENERAL TOLERANCE.	2017/07/25		DWG. No.		
4	Z191437	R.M	Nov./04/'19	H.I	CHK. T.Kurachi					
REV.	ECN	BY	DATE	APP.	APP.					
REVISION RECORD						Y.Shimada				

PATENT REGISTERED

PART NO.	Pos.
20849-020E-0#	20
20849-030E-0#	30
20849-040E-0#	40

BOTTOM VIEW

PATENT REGISTERED

20P

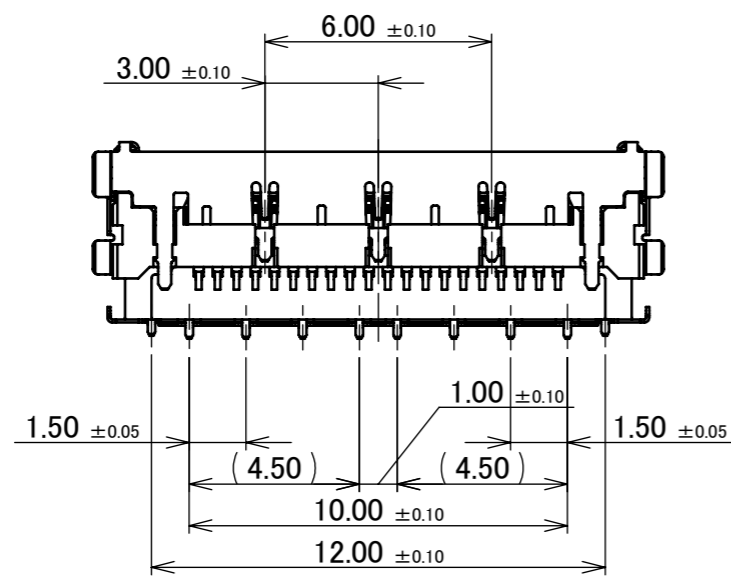

30P

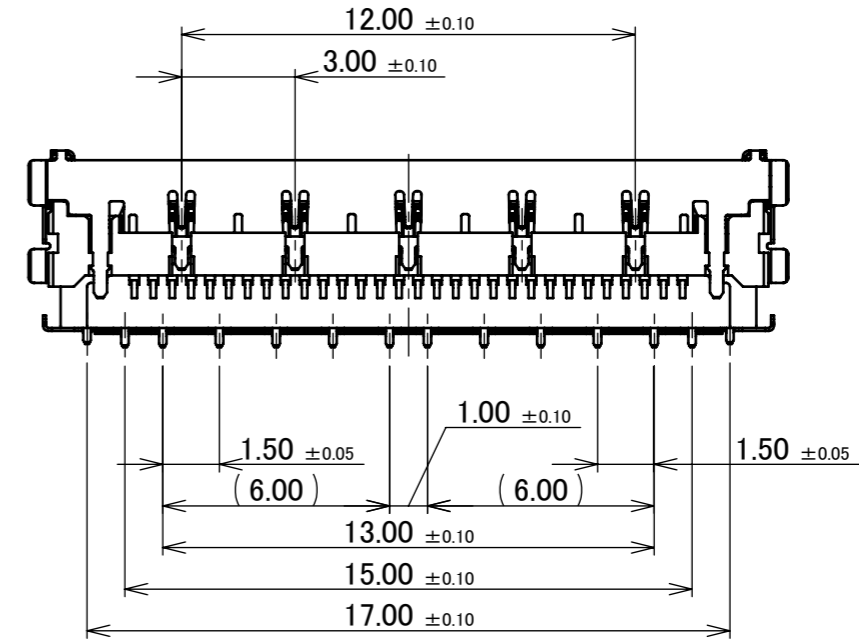

40P

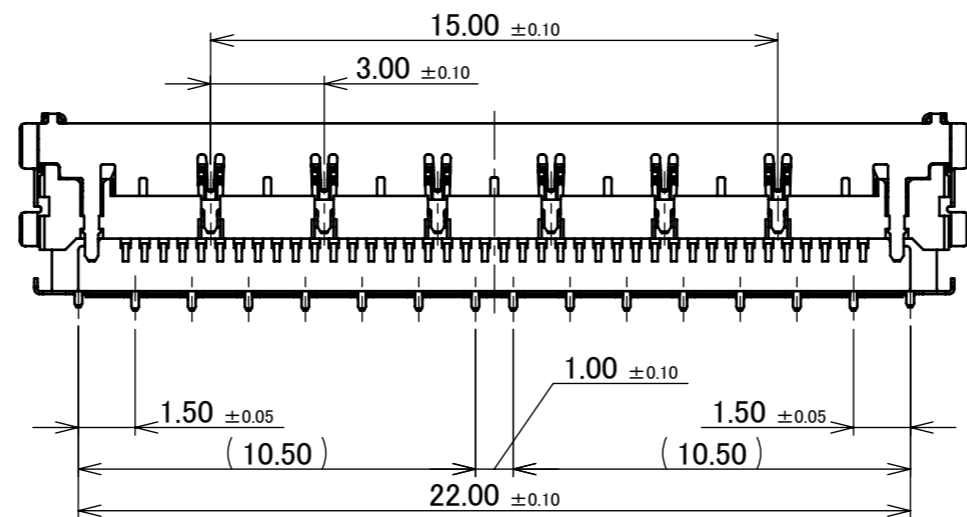

ANGLE	±2°	6 OVER 30 MAX.	±0.3	PROJECTION ⊕	SERIES No. R2	CUSTOMER COPY		
6 MAX.	±0.2	30 OVER 120 MAX.	±0.5					
GENERAL TOLERANCE.				TITLE CABLIN [®] -VS II RECE. ASS'Y	SCALE 5:1	I-PEX		
DWG.	DATE							
CHK.								
APP.								
				DWG. No.	20849	SIZE A3	SHEET 2/8	REV. 9

ITEMS	SPECIFICATION
APPLICABLE CABLE	MICRO COAX : AWG# 44 , 42 , 40 , 38 , 36 DISCRETE : AWG# 36 , 34 , 32 TWIN COAX : AWG# 40
RATING VOLTAGE	100V AC (PER CONTACT PIN)
RATING AMPERAGE (FOR CONTACT)	0.1A AC/DC [AWG#44] PER CONTACT PIN/UP TO 40 CONTACTS 0.24A AC/DC [AWG#42] PER CONTACT PIN/UP TO 40 CONTACTS 0.3A AC/DC [AWG#40] PER CONTACT PIN/UP TO 40 CONTACTS 0.5A AC/DC [AWG#38] PER CONTACT PIN/UP TO 23 CONTACTS 0.8A AC/DC [AWG#36] PER CONTACT PIN/UP TO 10 CONTACTS 1.0A AC/DC [AWG#34] FOR POWER PER CONTACT PIN/UP TO 9 CONTACTS 1.0A AC/DC [AWG#32] FOR POWER PER CONTACT PIN/UP TO 9 CONTACTS ※TESTING BY A REAL MACHINE IS RECOMMENDED BECAUSE TEMPERATURE RISE MAY AFFECTED BY ACTUAL SITUATION
OPERATING TEMPERATURE	233~378K(-40°C~+105°C)
OPERATING HUMIDITY	85% MAX.(NON-CONDENSING)
CONTACT RESISTANCE	INITIAL : 140mohm MAX.(AWG#32) / AFTER TEST : \triangle 40mohm MAX. 180mohm MAX.(AWG#34) 275mohm MAX.(AWG#36) 360mohm MAX.(AWG#38) 600mohm MAX.(AWG#40) 700mohm MAX.(AWG#42) 1080mohm MAX.(AWG#44)
GROUND SHELL RESISTANCE	INITIAL : 50mohm MAX. / AFTER TEST : \triangle 40mohm MAX.
INSULATION RESISTANCE	INITIAL : 1000Mohm MIN. / AFTER TEST : 500Mohm MIN.
DIELECTRIC WITHSTANDING VOLTAGE	AC250V 1min
DURABILITY	30 CYCLES
MATING FORCE (INITIAL / AFTER 30 CYCLES)	20P : 9.70N MAX. 30P : 14.55N MAX. 40P : 19.40N MAX.
UNMATING FORCE (INITIAL / AFTER 30 CYCLES)	20P : 2.00N MIN. 30P : 3.00N MIN. 40P : 4.00N MIN.
CABLE RETENTION FORCE	20P : 9.80N MIN. 30P : 14.70N MIN. 40P : 19.60N MIN.
COPLANARITY	0.10 MAX.
PRODUCT SPECIFICATION	PRS-2398
TEST REPORT	TR-17060 (20849-0**E-01) / TR-18048 (20849-0**E-02)
PACKING STANDARD	PST-17079
INSTRUCTION MANUAL	HIM-17015
ASSEMBLY MANUAL	ASM-17005
APPEARANCE CRITERIA No.	QLS-A***

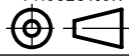
ANGLE	$\pm 2^\circ$	6 OVER 30 MAX.	± 0.3	PROJECTION 	SERIES No. R2	CUSTOMER COPY			
	6 MAX.	± 0.2	30 OVER 120 MAX.						± 0.5
GENERAL TOLERANCE.				TITLE CABLIN [®] -VS II RECE. ASS'Y	SCALE -	I-PEX			
DWG.	DATE								UNIT mm
CHK.									SIZE A3
APP.									SHEET 3/8
				DWG. No. 20849	REV. 9				

PATENT REGISTERED

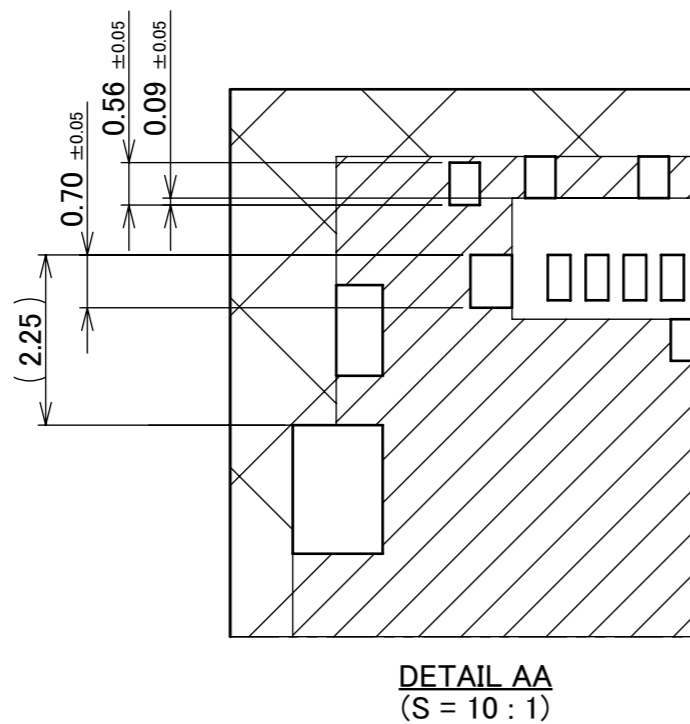
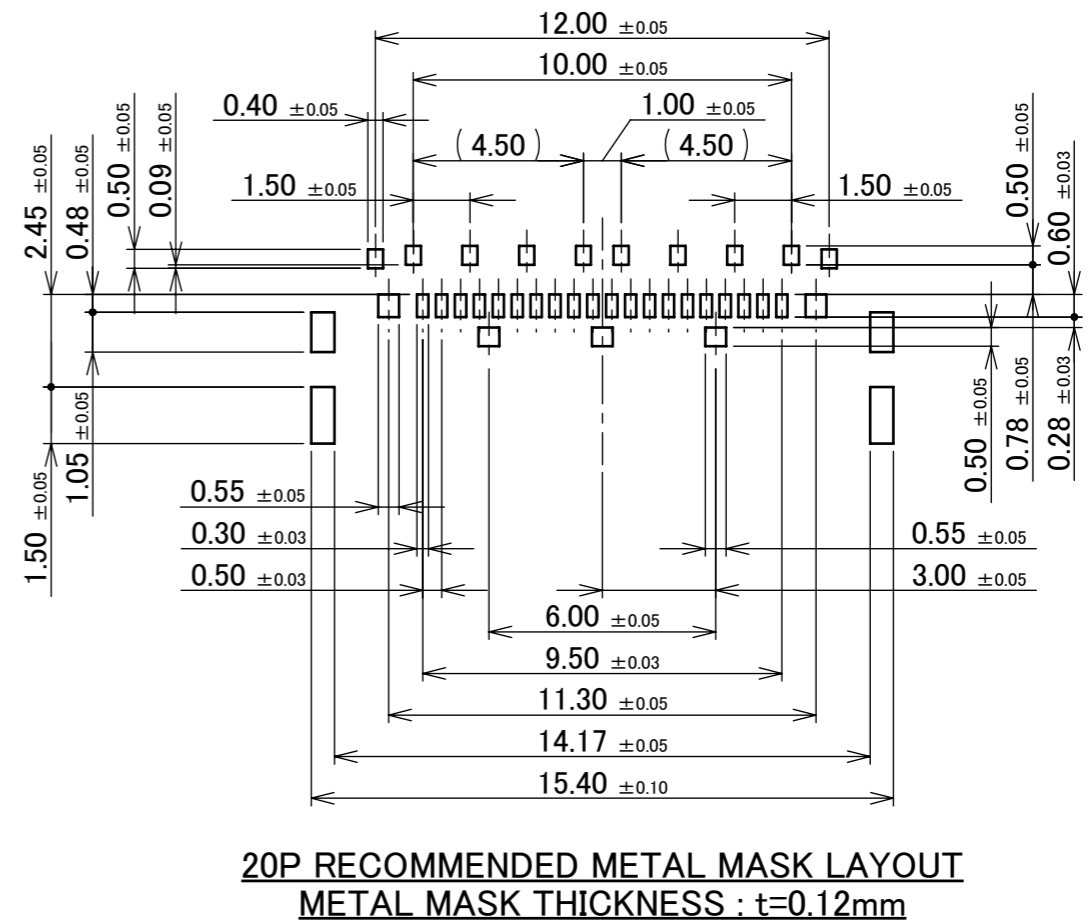
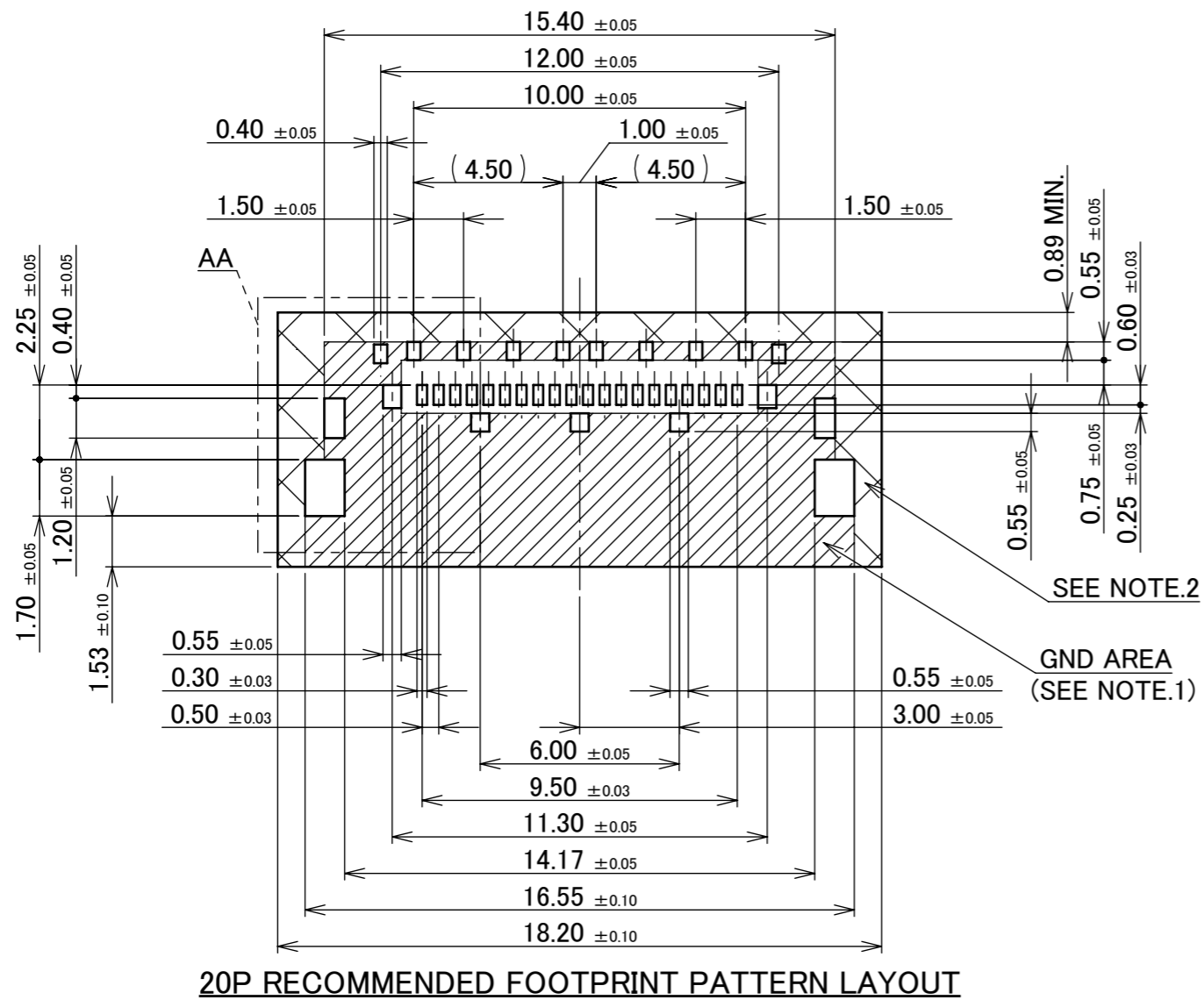

- NOTES.
1. SOLDER RESIST MUST BE APPLIED TO THIS AREA.
2. DO NOT MOUNT ANOTHER COMPONENT IN THIS AREA.

ANGLE	±2°	6 OVER 30 MAX.	±0.3	PROJECTION ⊕	SERIES No. R2	CUSTOMER COPY		
	6 MAX.	±0.2	30 OVER 120 MAX.					±0.5
GENERAL TOLERANCE.				TITLE		SCALE	I-PEX	
DWG.	DATE			CABLIN [®] -VS II RECE. ASS'Y		5:1		
CHK.						UNIT mm		
APP.				DWG. No.	20849	SIZE A3	SHEET 4/8	REV. 9

PATENT REGISTERED

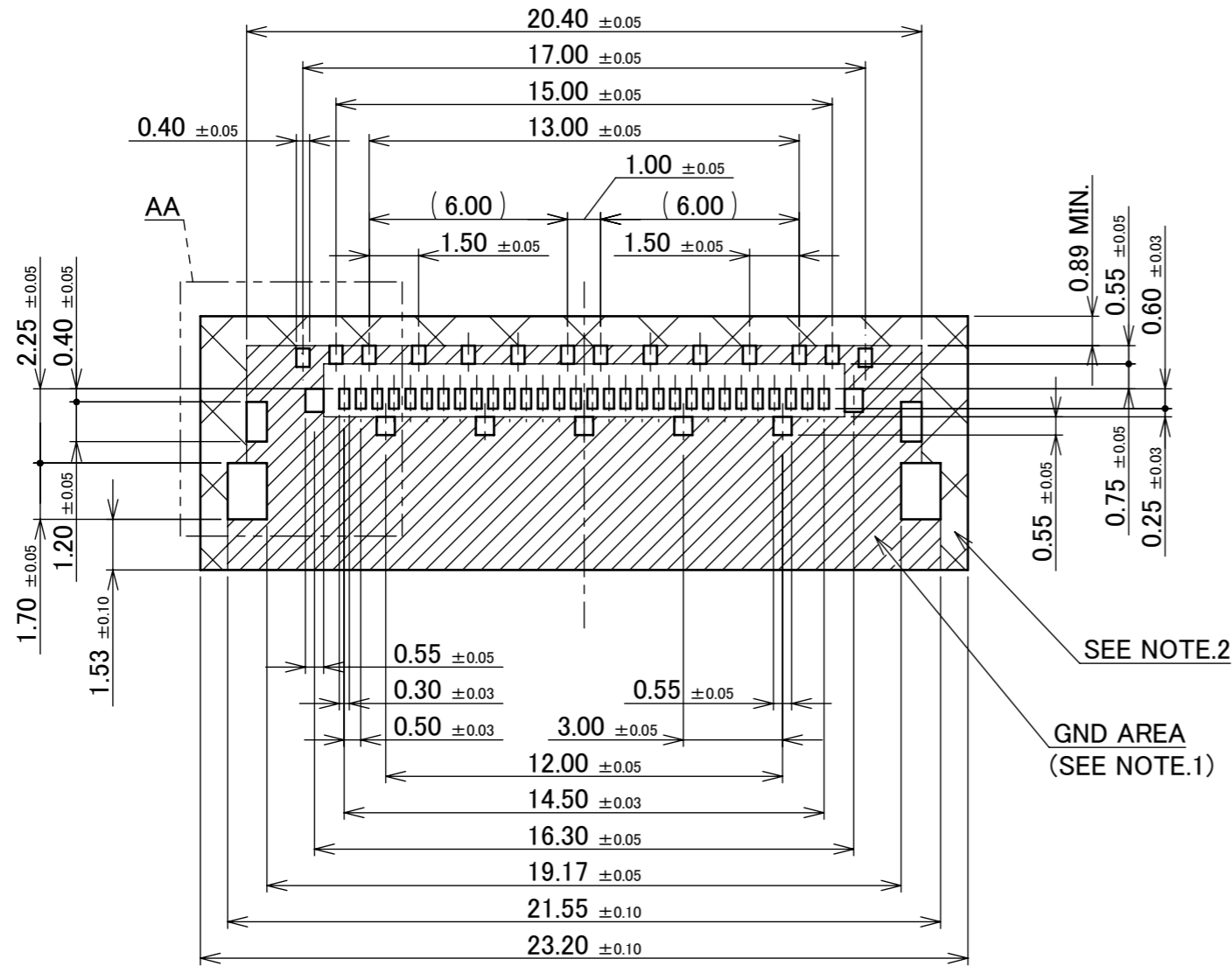

30P RECOMMENDED FOOTPRINT PATTERN LAYOUT

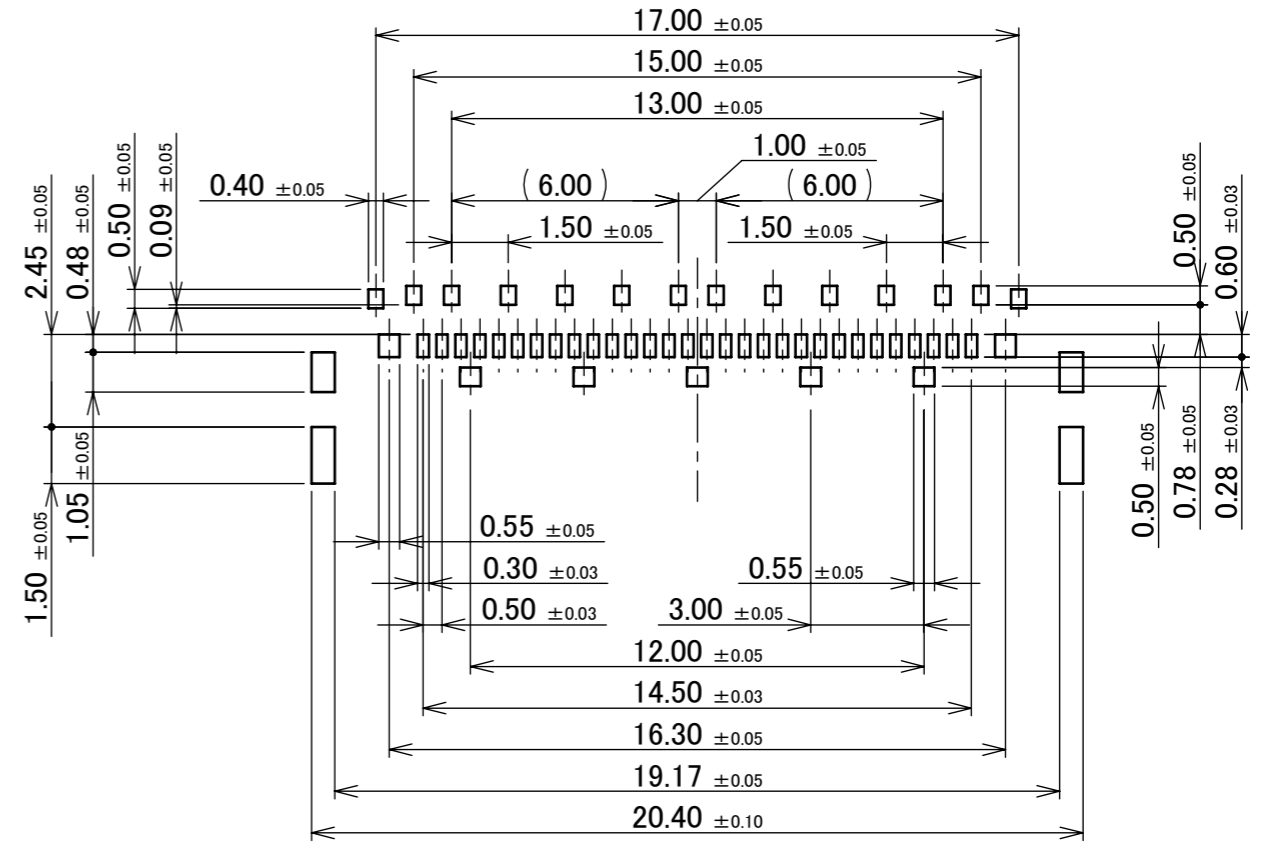

30P RECOMMENDED METAL MASK LAYOUT
METAL MASK THICKNESS : t=0.12mm

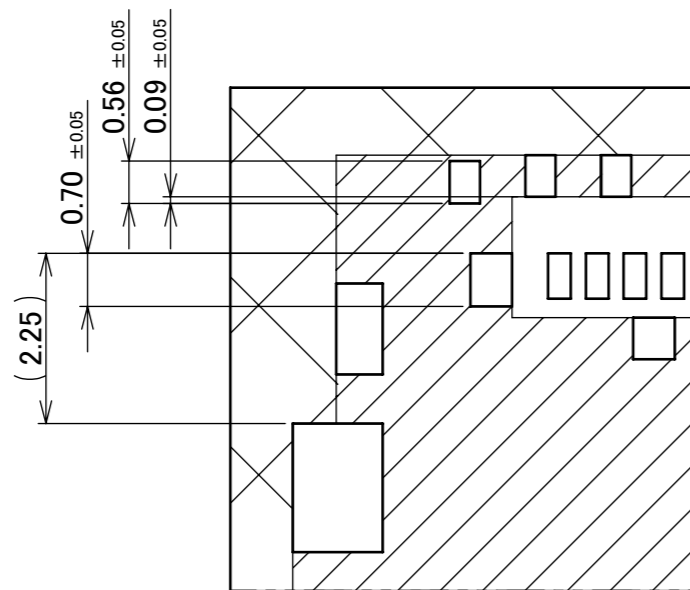

DETAIL AA
(S = 10 : 1)

NOTES.

1. SOLDER RESIST MUST BE APPLIED TO THIS AREA.
2. DO NOT MOUNT ANOTHER COMPONENT IN THIS AREA.

ANGLE	±2°	6 OVER 30 MAX.	±0.3	PROJECTION	SERIES No.	CUSTOMER COPY	
	6 MAX.	±0.2	30 OVER 120 MAX.	±0.5	R2		
GENERAL TOLERANCE.				TITLE	SCALE	I-PEX	
DWG.	DATE			CABLIN [®] -VS II RECE. ASS'Y	5:1		
CHK.				DWG. No.	UNIT		
APP.				20849	mm	SIZE	SHEET
					A3	5/8	REV.
							9

PATENT REGISTERED

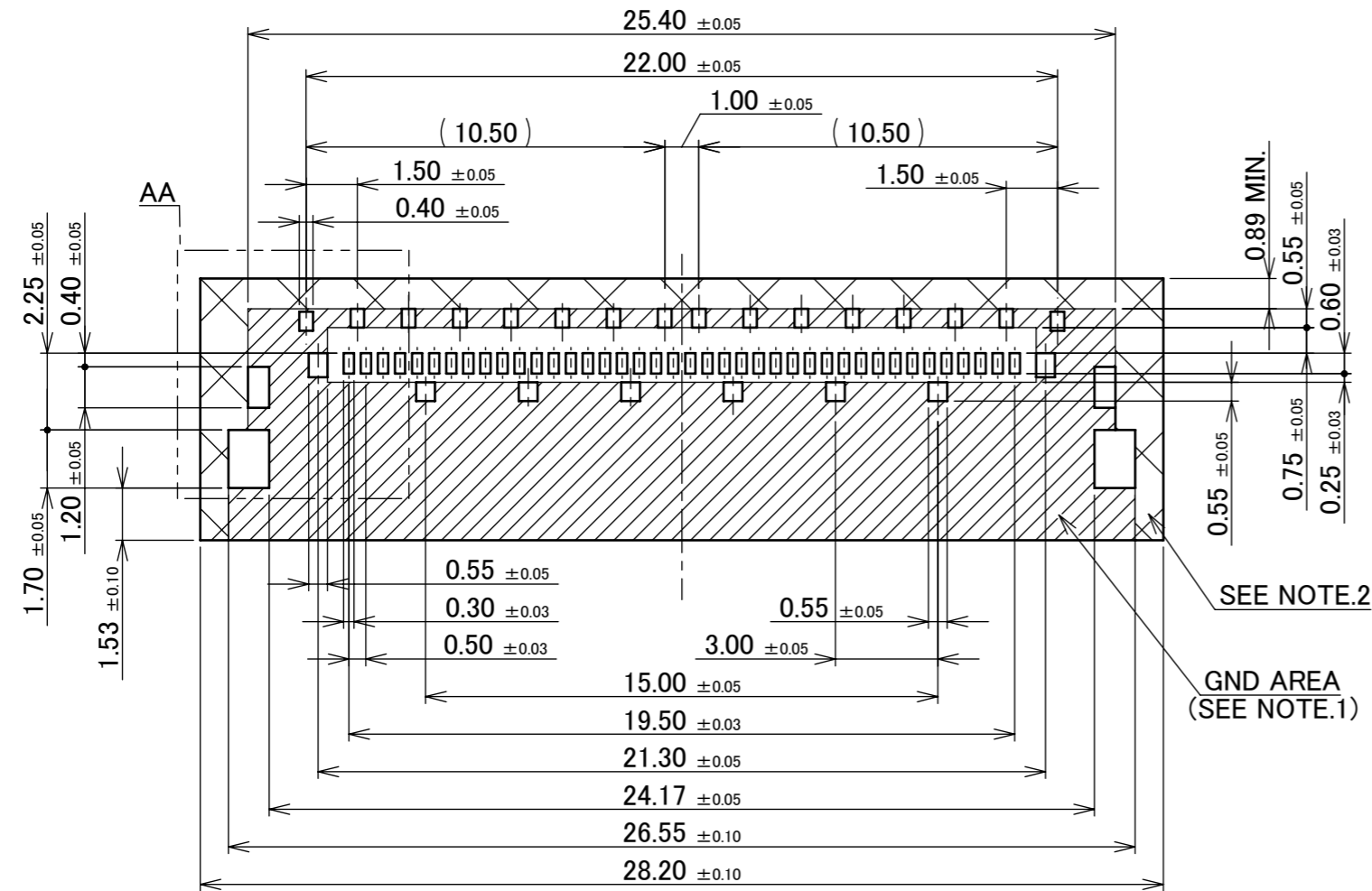

40P RECOMMENDED FOOTPRINT PATTERN LAYOUT

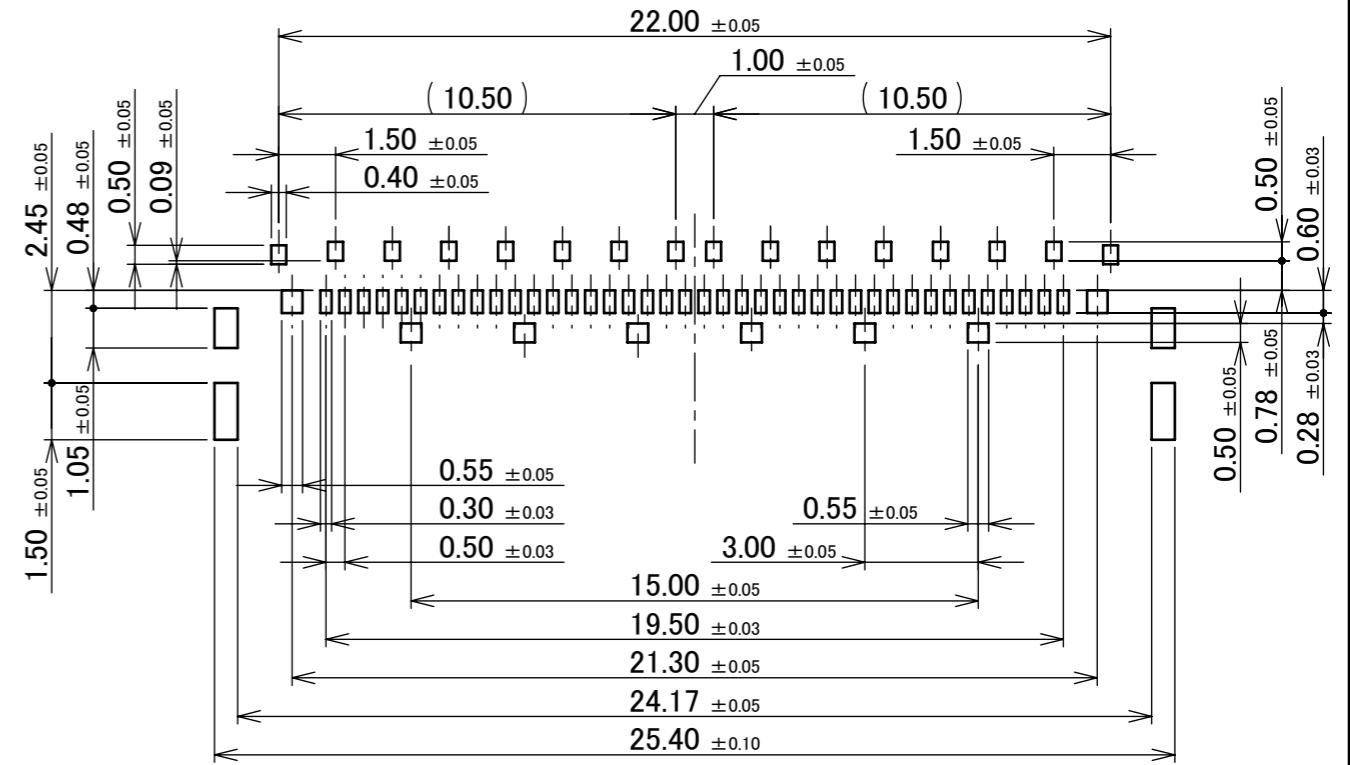

**40P RECOMMENDED METAL MASK LAYOUT
METAL MASK THICKNESS : t=0.12mm**

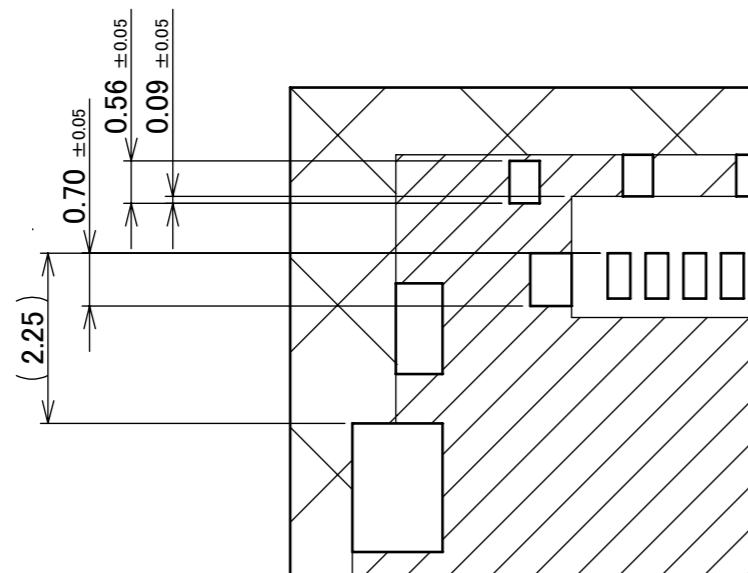

**DETAIL AA
(S = 10 : 1)**

- NOTES.
 1. SOLDER RESIST MUST BE APPLIED TO THIS AREA.
 2. DO NOT MOUNT ANOTHER COMPONENT IN THIS AREA.

ANGLE	±2°	6 OVER 30 MAX.	±0.3	PROJECTION	SERIES No.	CUSTOMER COPY	
	6 MAX.	±0.2	30 OVER 120 MAX.	⊕	R2		
GENERAL TOLERANCE.				TITLE	SCALE	I-PEX	
DWG.	DATE			CABLIN [®] -VS II RECE. ASS'Y	5:1		
CHK.					UNIT		
APP.				DWG. No.	20849	SIZE	SHEET
						A3	6/8
							REV.
							9

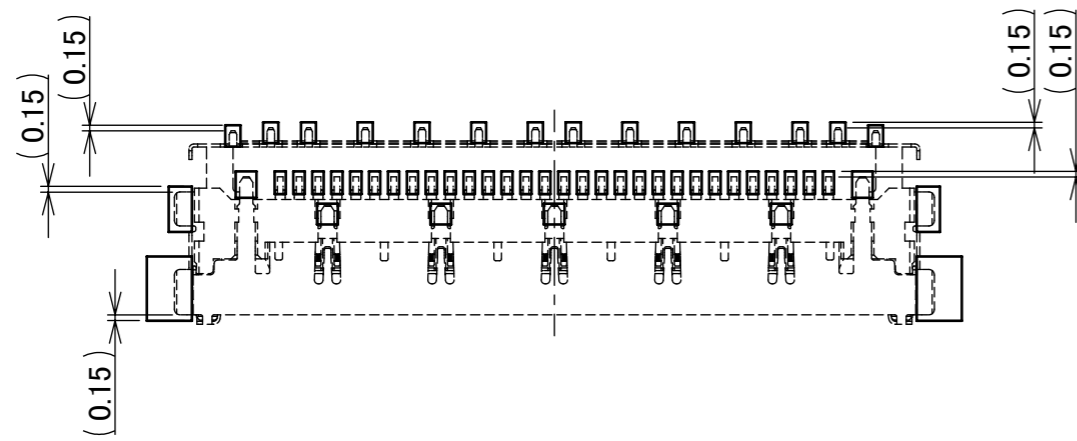

CONNECTOR ON RECOMMENDED FOOTPRINT PATTERN

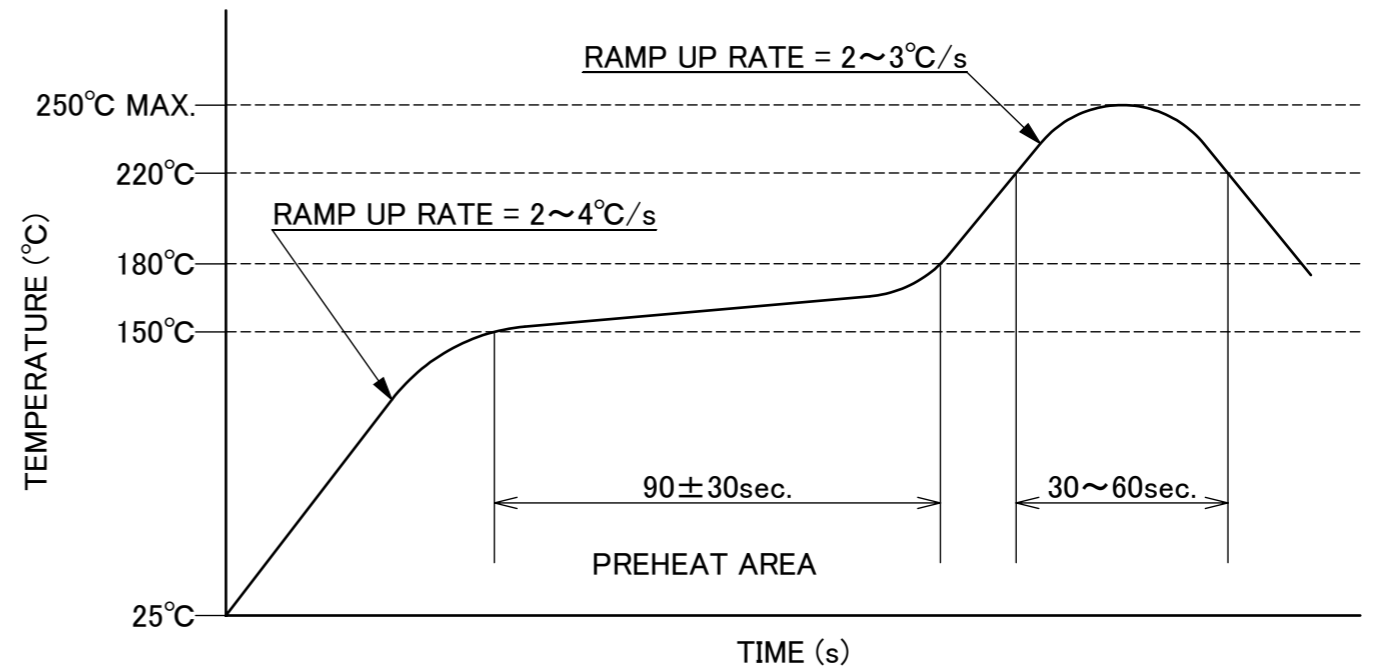

REFLOW TEMPERATURE PROFILE
 SENJU METAL INDUSTRY CO., LTD. : M705-SHF(Sn96.5 Ag3.0 Cu0.5)

ANGLE	±2°	6 OVER 30 MAX.	±0.3	PROJECTION 	SERIES No. R2	CUSTOMER COPY					
6 MAX.	±0.2	30 OVER 120 MAX.	±0.5								
GENERAL TOLERANCE.				TITLE CABLIN [®] -VS II RECE. ASS'Y	SCALE 5:1	I-PEX					
DWG.	DATE								UNIT mm		
CHK.									SIZE A3	SHEET 7/8	REV. 9
APP.									DWG. No. 20849		

PART NO.	M	N	P	Q	R	QTY. PER EMBOSS REEL (PIECES / REEL)	QTY. PER PACKING CARTON (REELS / CARTON)
20849-020E-0#	24.00	11.50	-	11.70	15.50	5500 / REEL	5 / CARTON = 27500
20849-030E-0#	32.00	14.20	28.40	16.70	20.50		4 / CARTON = 22000
20849-040E-0#	44.00	20.20	40.40	21.70	25.50		3 / CARTON = 16500

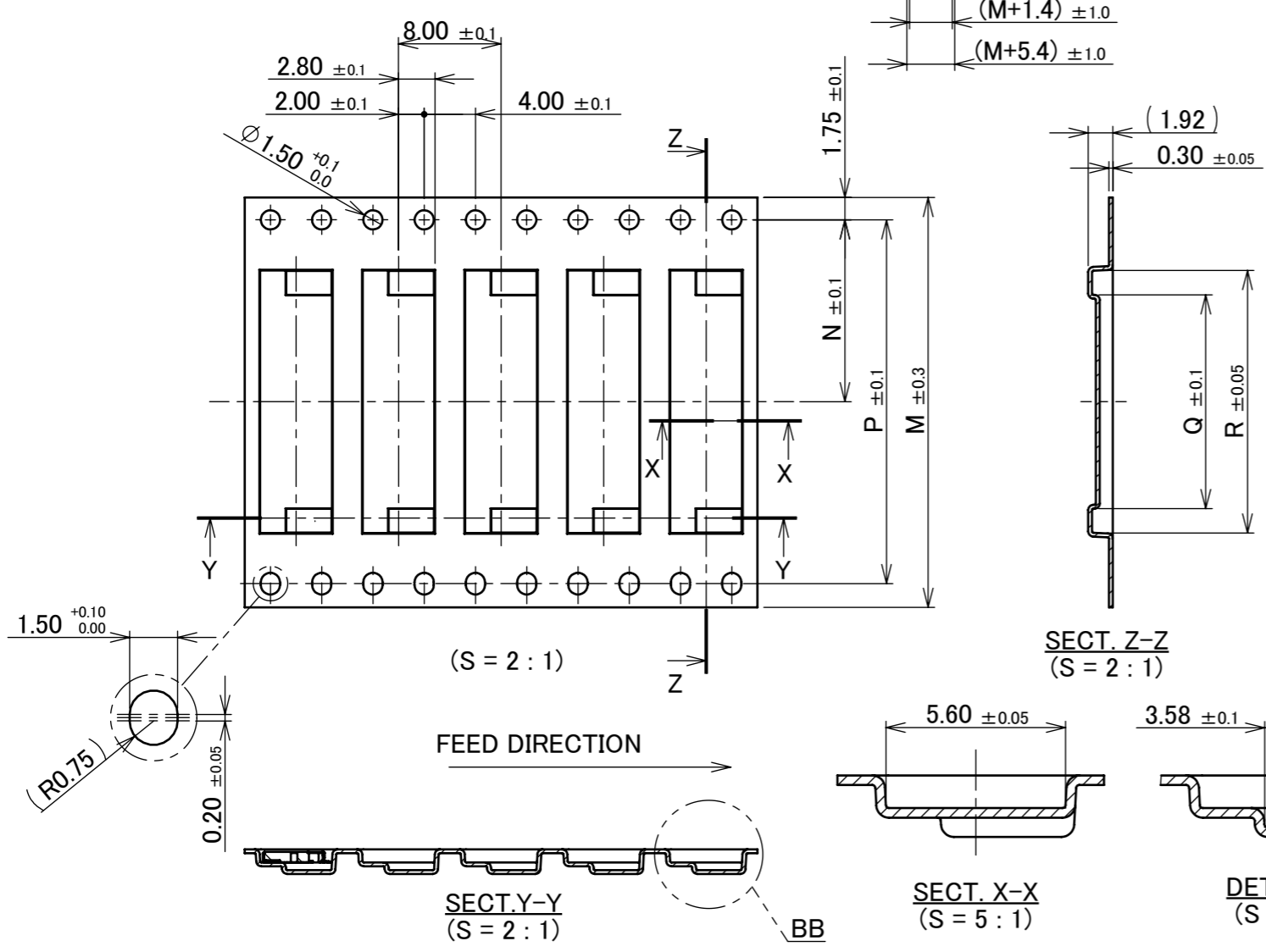
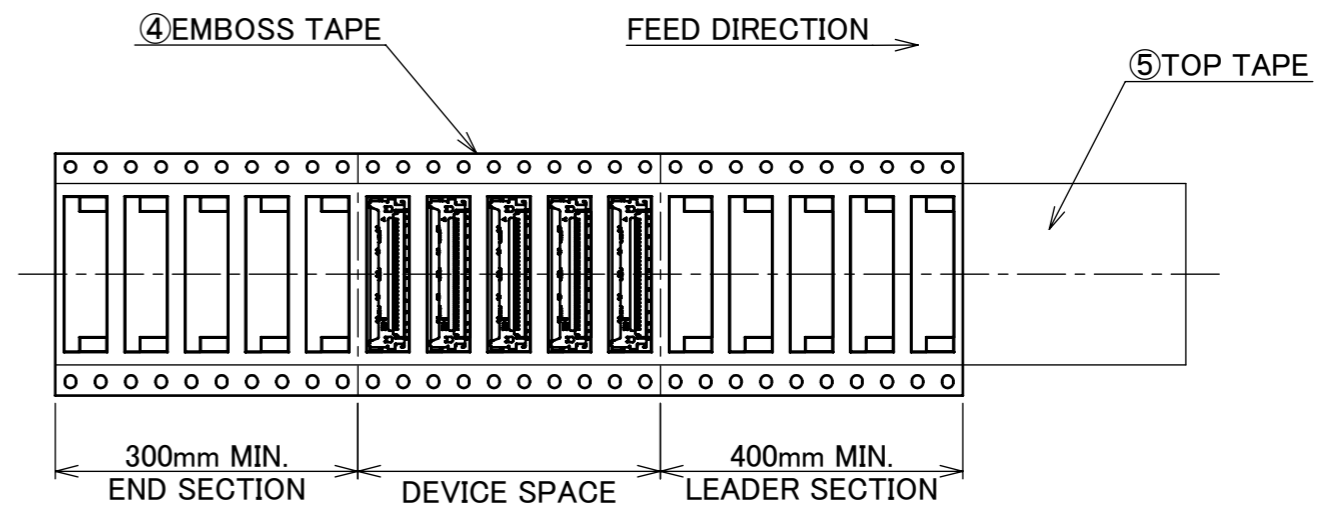
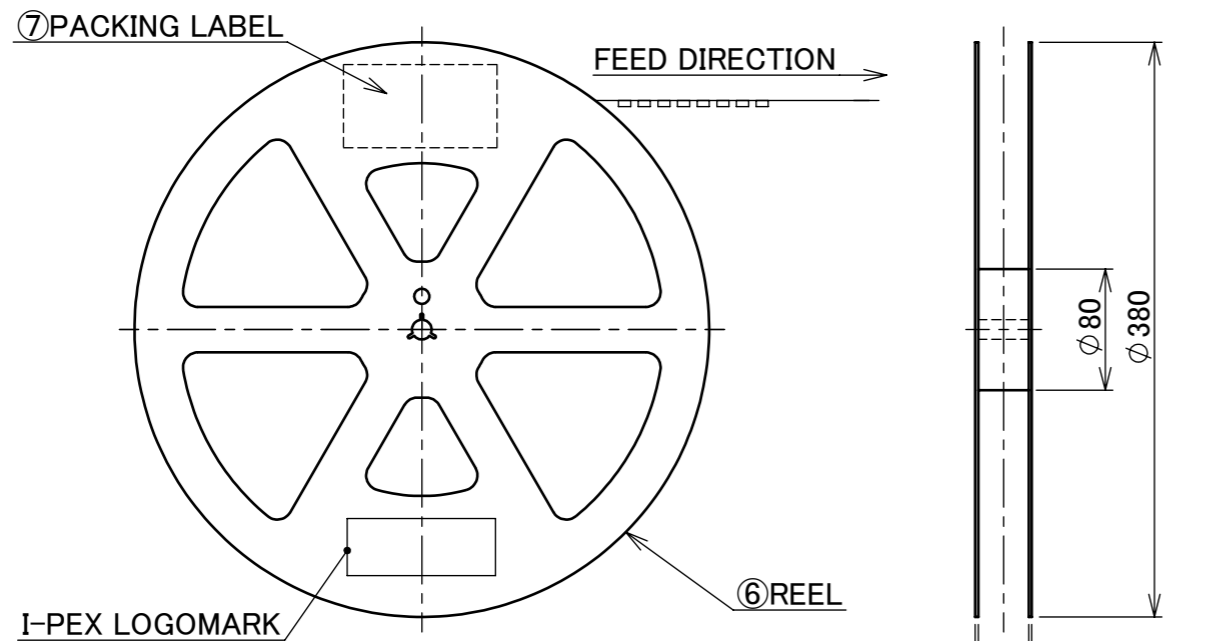

- NOTES.
 3. TAPING SPECIFICATION FOLLOWS JIS C 0806 (IEC 60286-3).
 4. MAKE EMPTY SECTION OF LEADER AND END ON EACH END OF THE TAPE.
 5. TOP TAPE SHALL NOT STICK OUT FROM EMBOSS TAPE.
 6. TOP TAPE SHALL NOT COVER FEED HOLE.

NO.	DISCRIPTION	MATERIAL	FINISH , REMARKS
7	PACKING LABEL	-	-
6	REEL	PS	ANTI-STATIC TYPE BLACK
5	TOP TAPE	PET t=0.062 TRANSPARENCY	ANTI-STATIC TYPE
4	EMBOSS TAPE	PS t=0.3 TRANSPARENCY	ANTI-STATIC TYPE

ANGLE	±2°	6 OVER 30 MAX.	±0.3	PROJECTION ⊕	SERIES No. R2	CUSTOMER COPY		
6 MAX.	±0.2	30 OVER 120 MAX.	±0.5					
GENERAL TOLERANCE.				TITLE CABLIN [®] -VS II RECE. ASS'Y	SCALE 1:X	UNIT mm		
DWG.	DATE							
CHK.								
APP.				DWG. No.	20849	SIZE A3	SHEET 8/8	REV. 9