

Recommended P/N 20846-0\*\*T-01

PART NO.	Pos.	A	B	C	D	E
20846-020T-0#	20	15.30	9.50	10.30	12.56	16.85
20846-030T-0#	30	20.30	14.50	15.30	17.56	21.85
20846-040T-0#	40	25.40	19.50	20.30	22.56	26.85

# PATENT REGISTERED



Halogen Free



RoHS Compliant

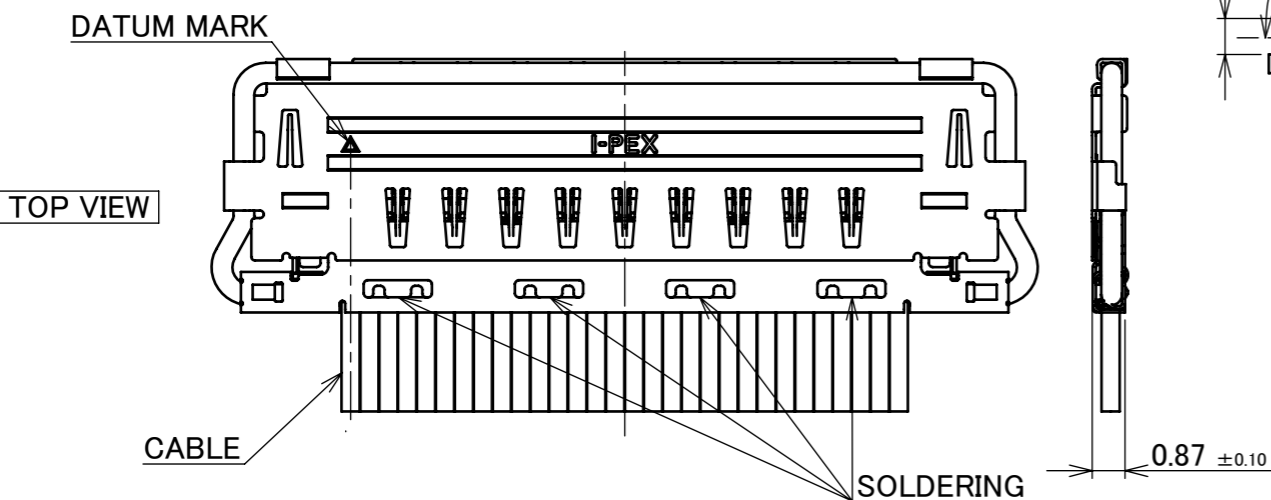
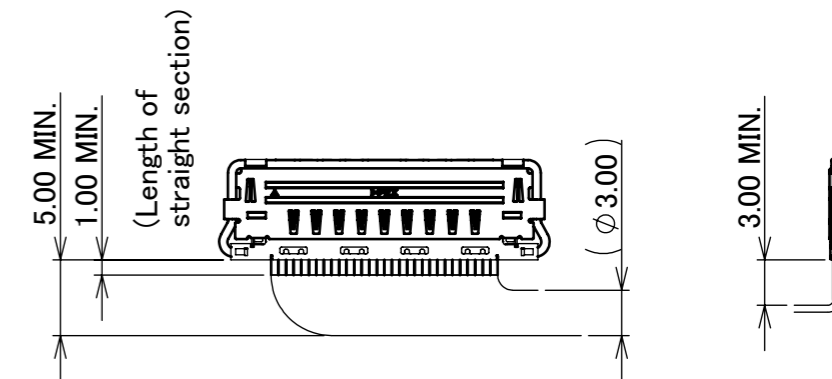
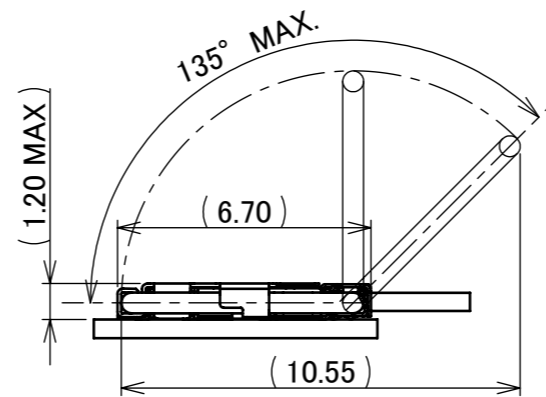
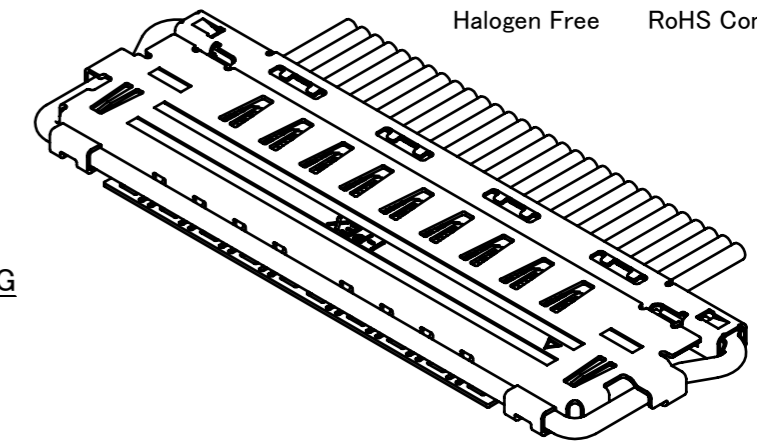
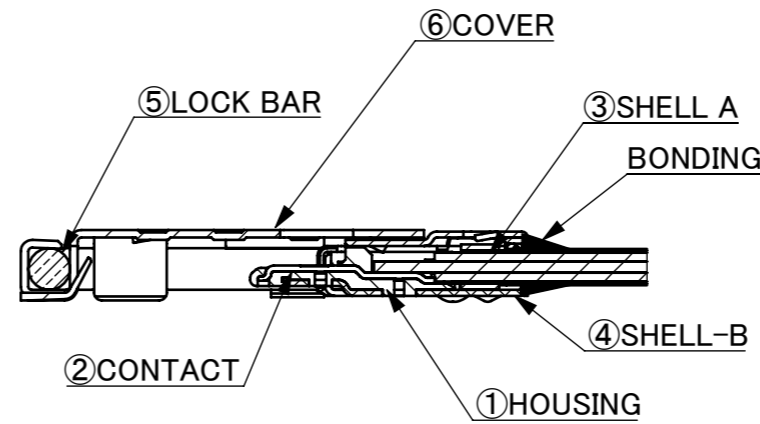
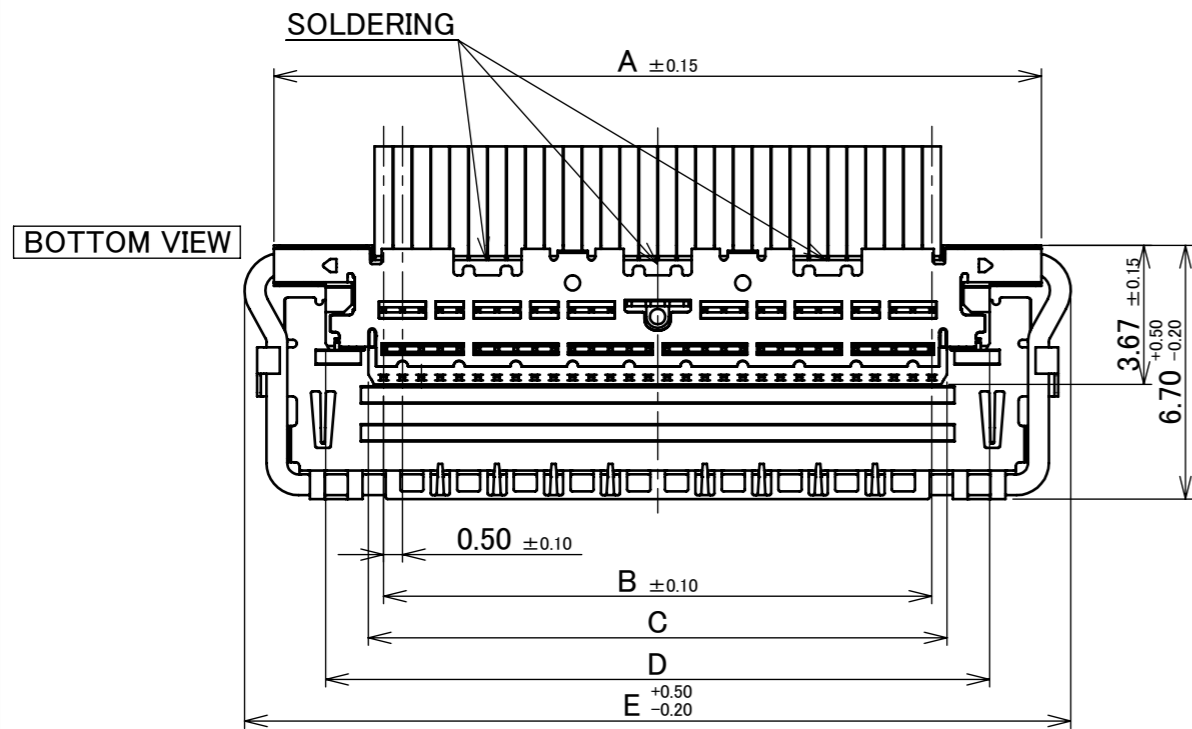

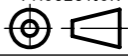

TABLE.1

PART NO.	CONTACT FINISH
20846-0**T-01	CONTACT & SOLDERING AREA : Au 0.03 μm MIN. OVER Ni 1.00 μm MIN.
20846-0**T-02	CONTACT AREA : Au 0.38 μm MIN. OVER Ni 1.27 μm MIN. SOLDERING AREA : Au 0.03 μm MIN. OVER Ni 1.00 μm MIN.

NO.	DISCRIPTION	MATERIAL	FINISH, REMARKS
6	COVER	PHOSPHOR BRONZE	ALL OVER Ni 1.00 μm MIN.
5	LOCK BAR	SUS	-
4	SHELL-B	PHOSPHOR BRONZE	PARTIAL Au 0.003 μm MIN. OVER Ni 1.00 μm MIN.
3	SHELL-A	PHOSPHOR BRONZE	PARTIAL Au 0.003 μm MIN. OVER Ni 1.00 μm MIN.
2	CONTACT	PHOSPHOR BRONZE	SEE TABLE 1
1	HOUSING	LCP	UL94V-0, BLACK

NO.	DISCRIPTION	MATERIAL	FINISH, REMARKS									
10	Z220121	M.N	Feb./04/'22	H.I	ANGLE	±2°	6 OVER 30 MAX.	±0.3	PROJECTION ⊕	SERIES No. R2R1R1	CUSTOMER COPY	
9	Z210548	M.N	May/26/'21	H.I	6 MAX.	±0.2	30 OVER 120 MAX.	±0.5				
8	Z191437	R.M	Nov./04/'19	H.I	GENERAL TOLERANCE.			TITLE CABLINER <sup>®</sup> -VS II PLUG CABLE ASS'Y	SCALE 5:1	UNIT mm	I-PEX	
7	Z190247	M.N	Feb./21/'19	Y.S	DWG.	K.Baba	DATE					2017/07/25
6	Z181497	M.N	Nov./16/'18	Y.S	CHK.	T.Kurachi	DATE	2017/07/25	DWG. No. 20846	SIZE A3	SHEET 1/3	REV. 10
5	Z181036	K.B	Aug./06/'18	Y.S	APP.	Y.Shimada	DATE	2017/07/26				
REV.	ECN	BY	DATE	APP.	REVISION RECORD							

ITEMS	SPECIFICATION
APPLICABLE CABLE	MICRO COAX : AWG# 44 , 42 , 40 , 38 , 36 DISCRETE : AWG# 36 , 34 , 32 TWIN COAX : AWG# 40
RATING VOLTAGE	100V AC (PER CONTACT)
RATING AMPERAGE (FOR CONTACT)	0.1A AC/DC [AWG#44] PER CONTACT/UP TO 40 CONTACTS 0.24A AC/DC [AWG#42] PER CONTACT/UP TO 40 CONTACTS 0.3A AC/DC [AWG#40] PER CONTACT/UP TO 40 CONTACTS 0.5A AC/DC [AWG#38] PER CONTACT/UP TO 23 CONTACTS 0.8A AC/DC [AWG#36] PER CONTACT/UP TO 10 CONTACTS 1.0A AC/DC [AWG#34] FOR POWER PER CONTACT/UP TO 9 CONTACTS 1.0A AC/DC [AWG#32] FOR POWER PER CONTACT/UP TO 9 CONTACTS ※TESTING BY A REAL MACHINE IS RECOMMENDED BECAUSE TEMPERATURE RISE MAY AFFECTED BY ACTUAL SITUATION
OPERATING TEMPERATURE	233~378K(-40°C~+105°C)
OPERATING HUMIDITY	85% MAX.(NON-CONDENSING)
CONTACT RESISTANCE	INITIAL : 140mohm MAX.(AWG#32) / AFTER TEST : $\triangle$ 40mohm MAX. 180mohm MAX.(AWG#34) 275mohm MAX.(AWG#36) 360mohm MAX.(AWG#38) 600mohm MAX.(AWG#40) 700mohm MAX.(AWG#42) 1080mohm MAX.(AWG#44)
GROUND SHELL RESISTANCE	INITIAL : 50mohm MAX. / AFTER TEST : $\triangle$ 40mohm MAX.
INSULATION RESISTANCE	INITIAL : 1000Mohm MIN. / AFTER TEST : 500Mohm MIN.
DIELECTRIC WITHSTANDING VOLTAGE	AC250V 1min
DURABILITY	30 CYCLES
MATING FORCE (INITIAL / AFTER 30 CYCLES)	20P : 9.70N MAX. 30P : 14.55N MAX. 40P : 19.40N MAX.
UNMATING FORCE (INITIAL / AFTER 30 CYCLES)	20P : 2.00N MIN. 30P : 3.00N MIN. 40P : 4.00N MIN.
CABLE RETENTION FORCE	20P : 9.80N MIN. 30P : 14.70N MIN. 40P : 19.60N MIN.
PRODUCT SPECIFICATION	PRS-2398
TEST REPORT	TR-17060 (20846-0**T-01) / TR-18048 (20846-0**T-02)
INSTRUCTION MANUAL	HIM-17015
ASSEMBLY MANUAL	ASM-17005
APPEARANCE CRITERIA No.	QLS-A***

ANGLE	$\pm 2^\circ$	6 OVER 30 MAX.	$\pm 0.3$	PROJECTION 	SERIES No. R2R1R1	CUSTOMER COPY		
6 MAX.	$\pm 0.2$	30 OVER 120 MAX.	$\pm 0.5$					
GENERAL TOLERANCE.				TITLE CABLIN <sup>®</sup> -VS II PLUG CABLE ASS'Y	SCALE 5:1 UNIT mm			
DWG.	DATE							
CHK.								
APP.								
				DWG. No.	20846	SIZE A3	SHEET 2/3	REV. 10

PART NO.	Pos.	B	G
20846-020T-0#	20	9.50	10.70
20846-030T-0#	30	14.50	15.70
20846-040T-0#	40	19.50	20.70

# PATENT REGISTERED

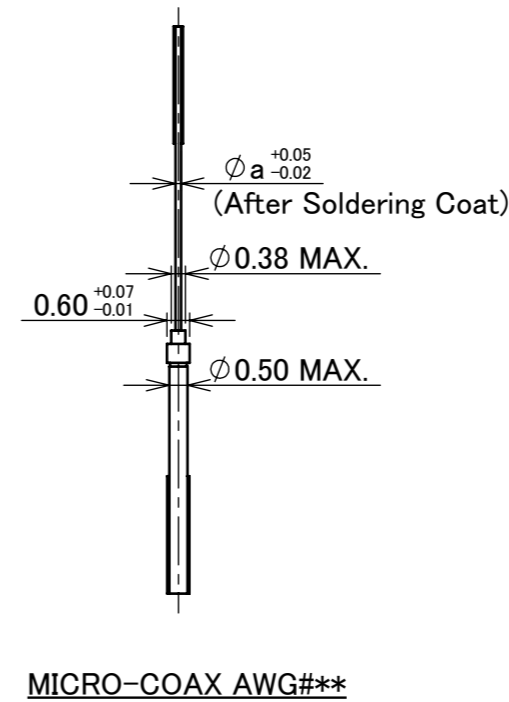
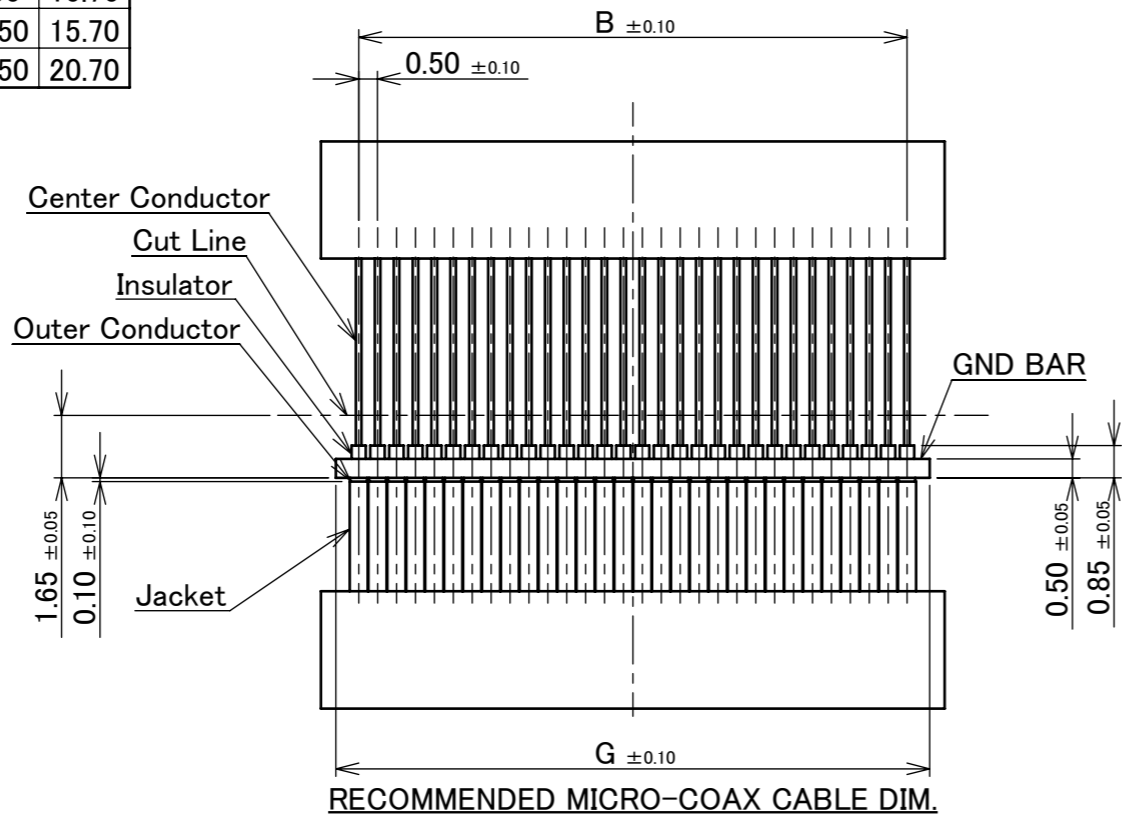

MICRO-COAX DIMENSION

	a
#36	0.15
#38	0.12
#40	0.09
#42	0.075
#44	0.063

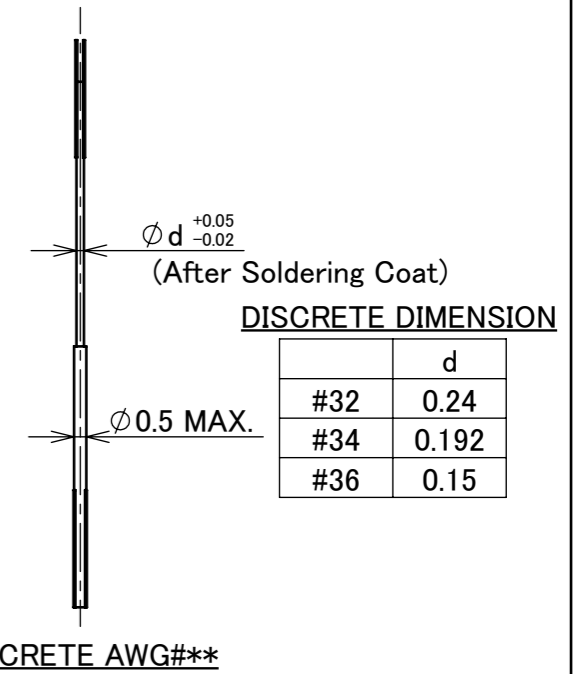
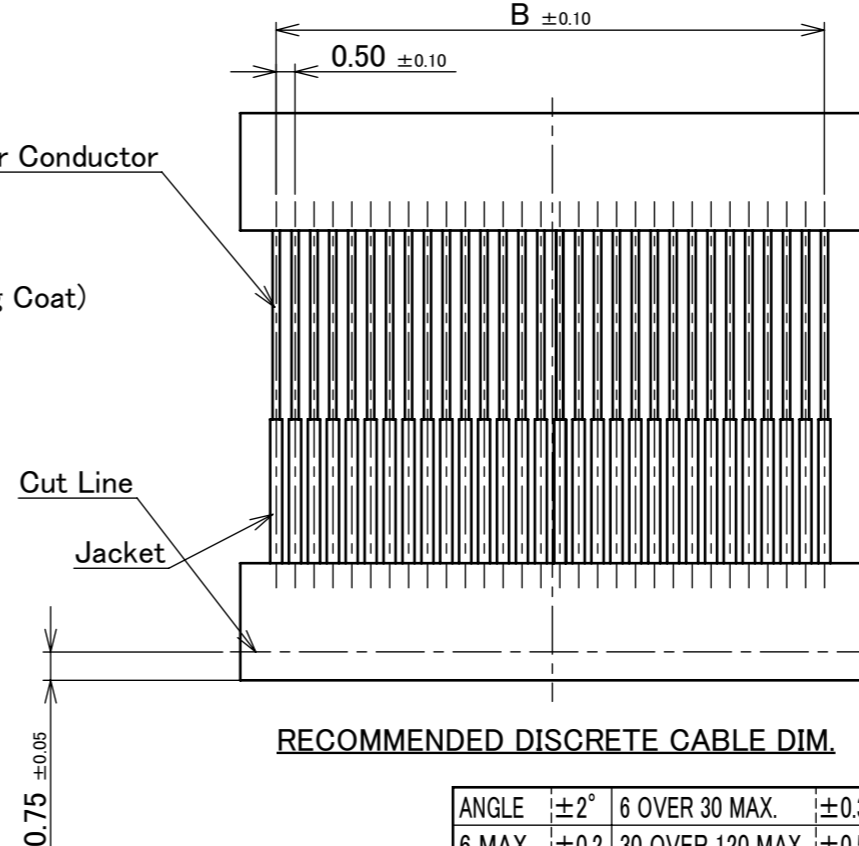
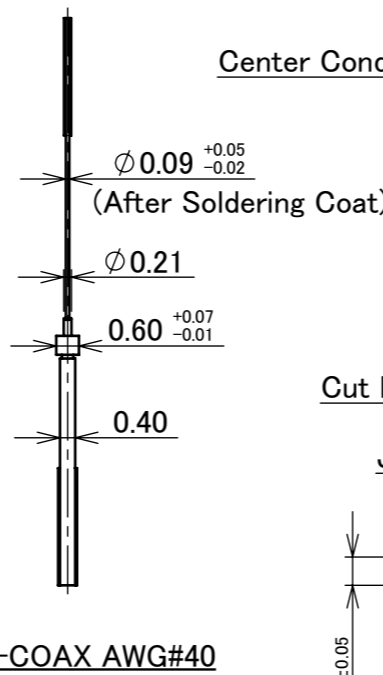
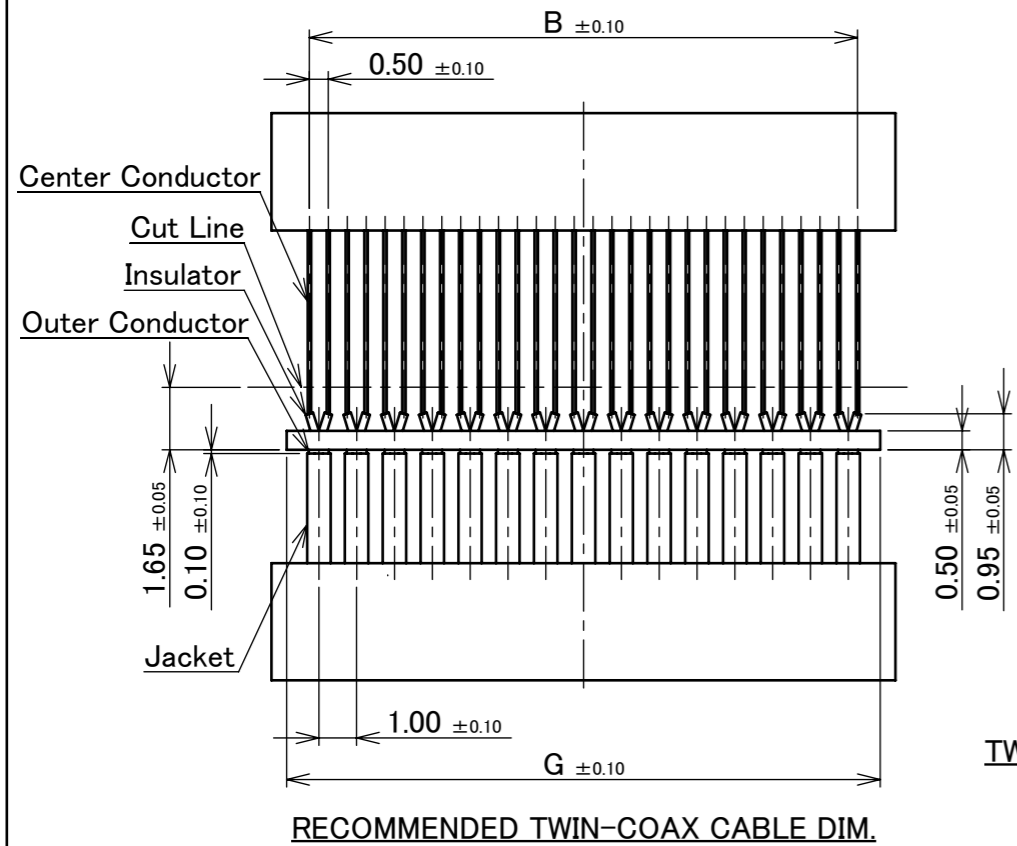

DISCRETE DIMENSION

	d
#32	0.24
#34	0.192
#36	0.15

ANGLE	±2°	6 OVER 30 MAX.	±0.3	PROJECTION ⊕	SERIES No. R2R1R1	CUSTOMER COPY	
	6 MAX.	±0.2	30 OVER 120 MAX.				
GENERAL TOLERANCE.				TITLE CABLIN® -VS II PLUG CABLE ASS'Y		SCALE 5:1	I-PEX
DWG.	DATE			DWG. No. 20846		UNIT mm	
CHK.				SIZE A3		SHEET 3/3	
APP.						REV. 10	