

Recommended P/N 20645-0**T-01

PART No.	A	B	C
20645-030T-01	19.30	17.56	20.05
20645-040T-01	24.30	22.56	25.05



Halogen Free



RoHS Compliant

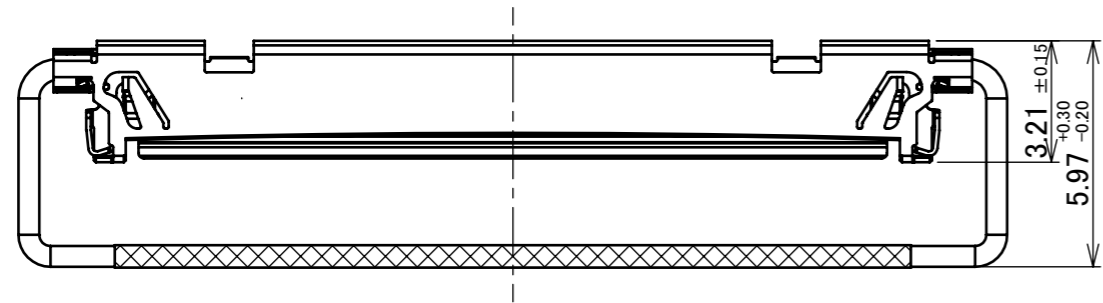
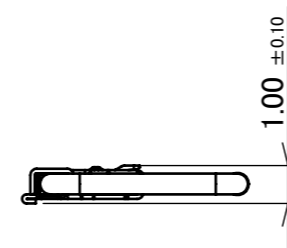
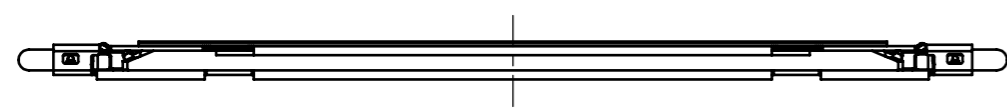
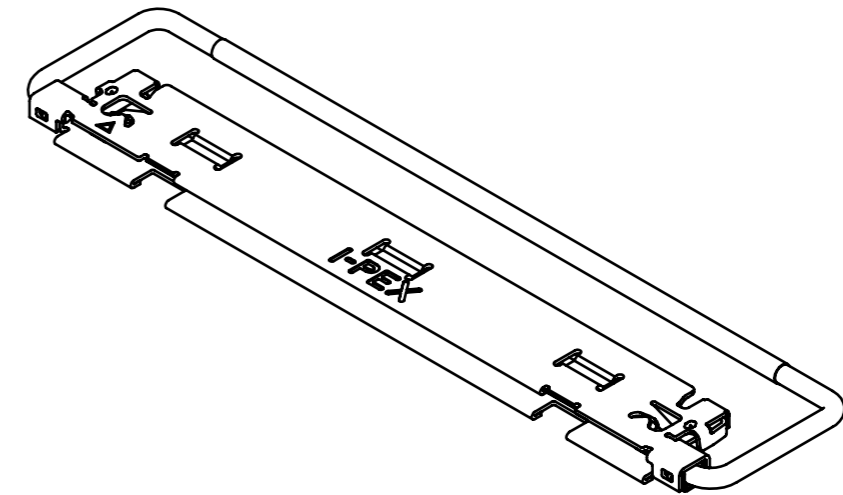
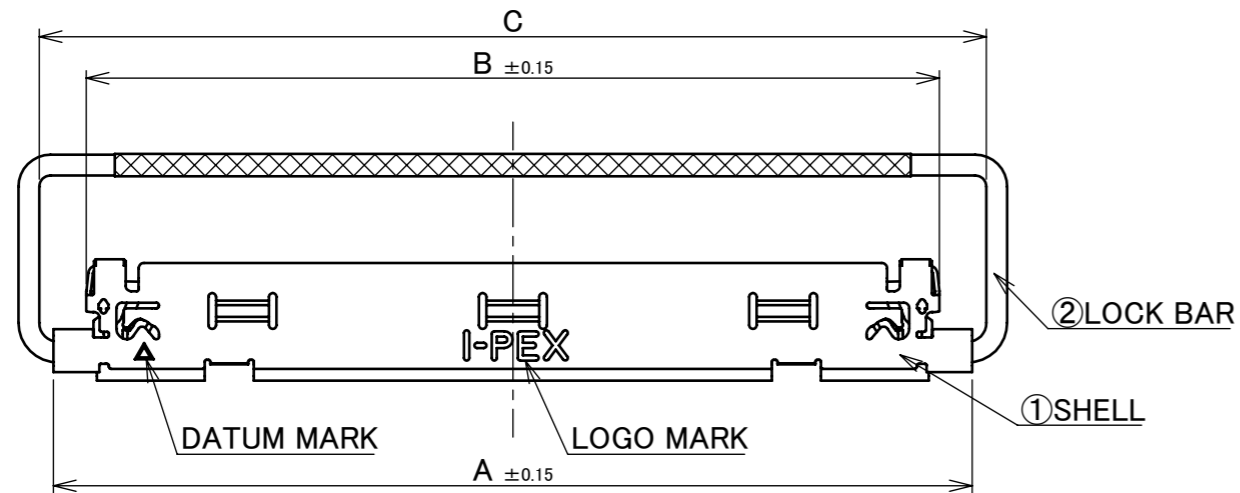

2	LOCK BAR	SUS	-
1	SHELL	PHOSPHOR BRONZE	ALL OVER Ni 1.00 μm MIN. CONTACT & SOLDERING AREA : Au 0.01 μm MIN.
NO.	DISCRIPTION	MATERIAL	FINISH , REMARKS

12	Z230400	T.O	Apr./06/'23	H.I	ANGLE	±2°	6 OVER 30 MAX.	±0.3	PROJECTION ⊕	SERIES No. R0	CUSTOMER COPY	
11	Z230352	T.O	Mar./27/'23	H.I	6 MAX.	±0.2	30 OVER 120 MAX.	±0.5				
10	Z220132	M.M	Feb./08/'22	H.I	GENERAL TOLERANCE.				TITLE CABLINER [®] -VSF PLUG SHELL ASS'Y	SCALE 5:1 UNIT mm	I-PEX	
9	Z191380	R.F	Oct./15/'19	H.I	DWG.	DATE		2014/11/07				
8	Z191207	T.O	Sept./12/'19	H.I	H.Aoki							
7	Z181328	Y.Sasa	Nov./19/'18	H.I	CHK. J.Tateishi							
REV.	ECN	BY	DATE	APP.	APP.	E.Kawabe		DWG. No.	20645	SIZE A3	SHEET 1/6	REV. 12

Confidential C

I-PEX Inc.

QKE-DFE06-02 REV.12

POS.	A	B	D	E	H
30	19.30	17.56	14.50	15.30	21.15
40	24.30	22.56	19.50	20.30	26.15

FPC ASS'Y STATE



Halogen Free



RoHS Compliant

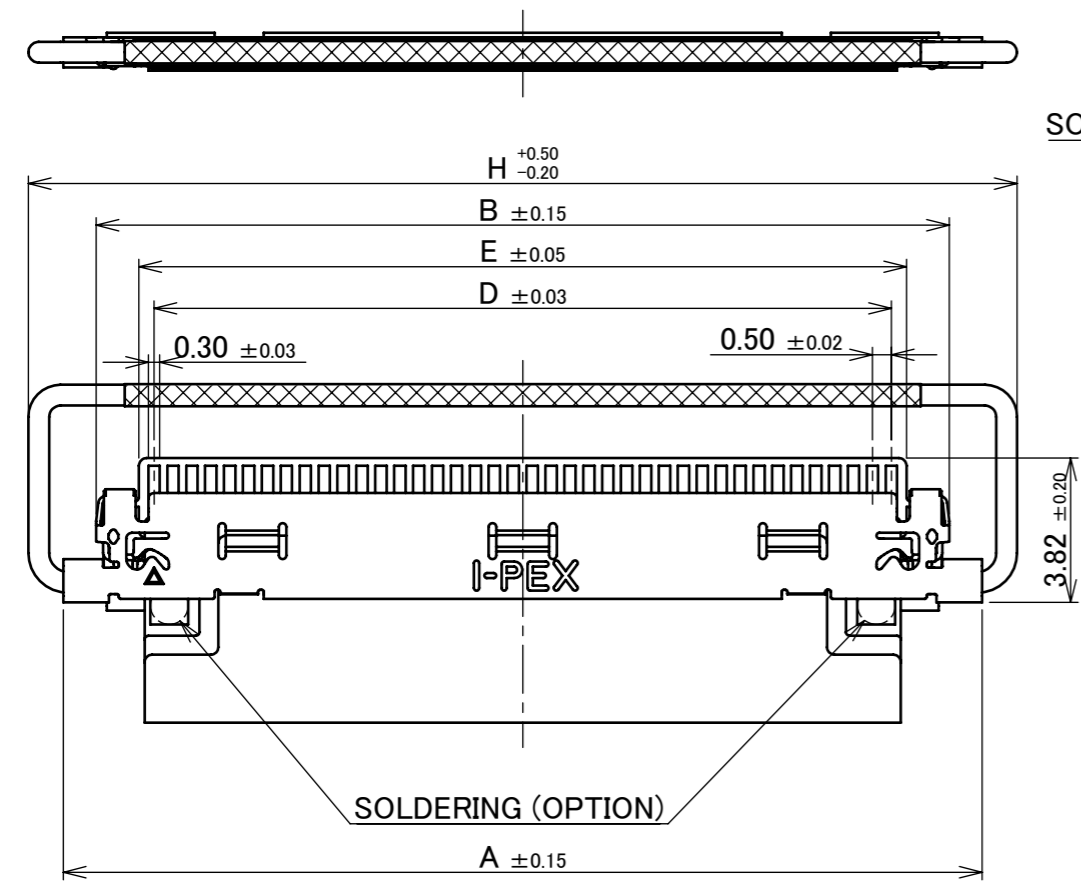

SOLDERING (OPTION)

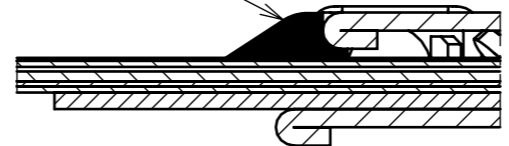

DETAIL BB
(S=20/1)

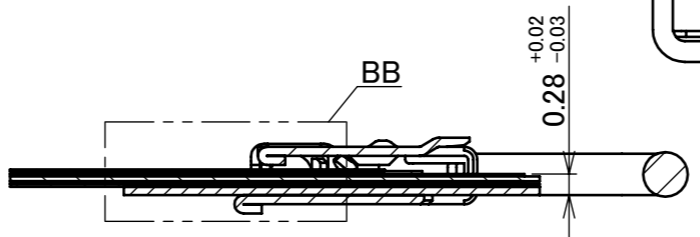

SECT AA-AA
(S=10/1)

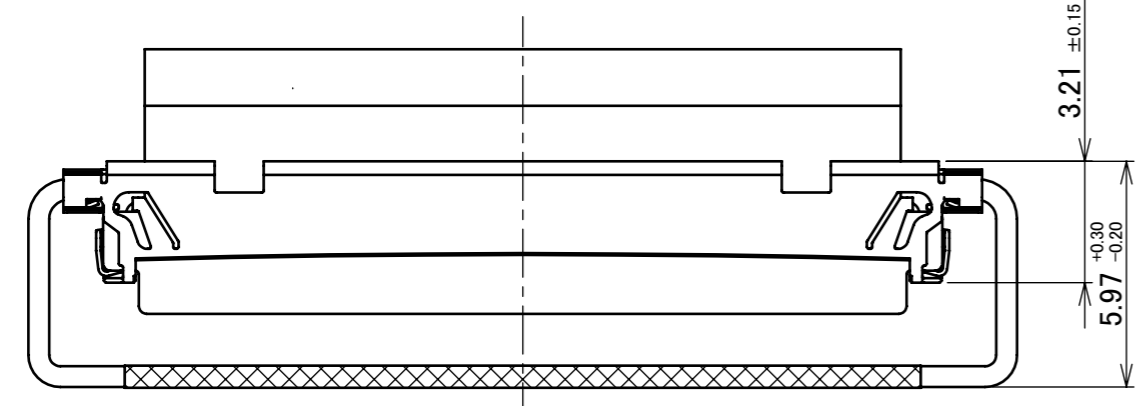
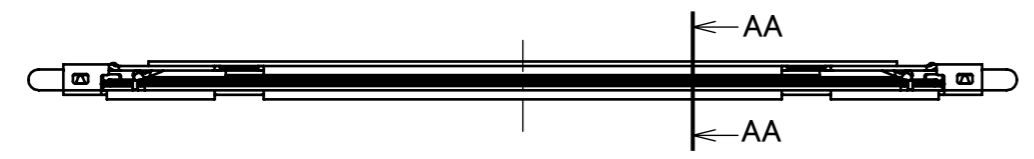
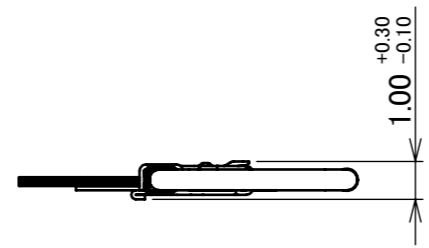

PLUG SHELL ASS'Y: CABLINE-VSF
P/N: 20645-0**T-01

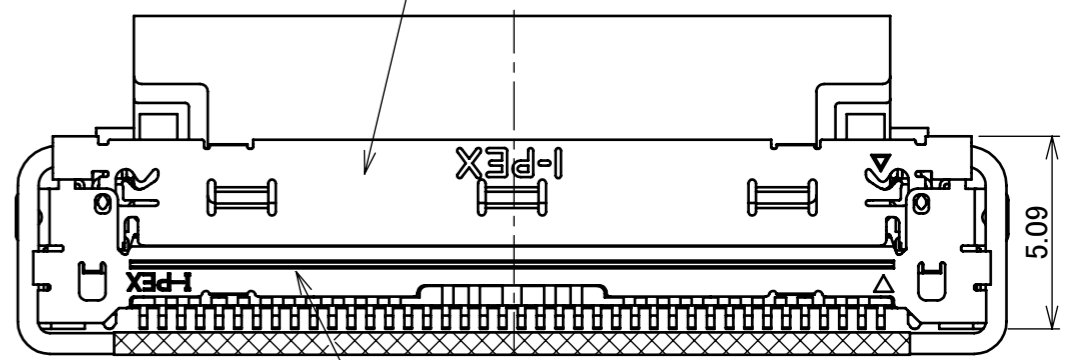

RECE: CABLINE-VS
P/N: 20455-0**E-***

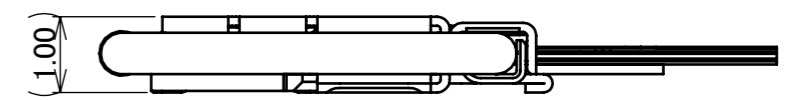

MATING CONDITION

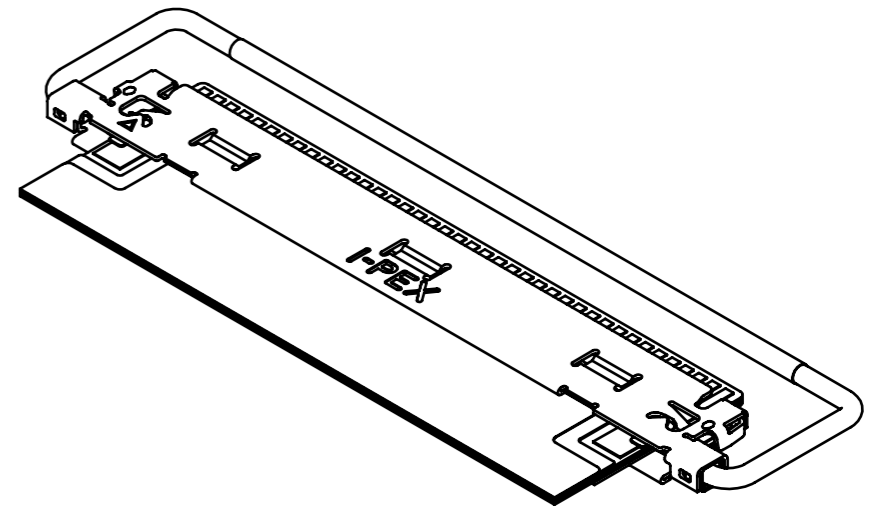

ANGLE	±2°	6 OVER 30 MAX.	±0.3	PROJECTION ⊕	SERIES No. R0	CUSTOMER COPY			
6 MAX.	±0.2	30 OVER 120 MAX.	±0.5						
GENERAL TOLERANCE.				TITLE CABLINE® -VSF PLUG SHELL ASS'Y		SCALE 5:1	I-PEX		
DWG.	DATE			DWG. No. 20645		UNIT mm			

ITEMS	SPECIFICATION
RATING VOLTAGE	100V AC (PER CONTACT)
RATING AMPERAGE (FOR SIGNAL CONTACT)	0.3A AC/DC (PER CONTACT)
OPERATING TEMPERATURE	233~358K(-40°C~+85°C)
OPERATING HUMIDITY	85% MAX.(NON-CONDENSING)
CONTACT RESISTANCE (FOR SIGNAL CONTACT)	INITIAL : 60mohm MAX. / AFTER TEST : \triangleleft 40mohm MAX.
GROUND SHELL RESISTANCE	INITIAL : 60mohm MAX. / AFTER TEST : \triangleleft 40mohm MAX.
INSULATION RESISTANCE	INITIAL : 1000Mohm MIN. / AFTER TEST : 500Mohm MIN.
DIELECTRIC WITHSTANDING VOLTAGE	AC250V 1min
DURABILITY	30 CYCLES
MATING FORCE (INITIAL / AFTER TEST)	30P : 24.0N MAX. / 40P : 32.0N MAX.
UNMATING FORCE (INITIAL / AFTER TEST)	30P : 1.1N MIN. / 40P : 1.4N MIN.
PRODUCT SPECIFICATION	PRS-1878
TEST REPORT	TR-14095, TR-17048
PACKING STANDARD	PST-14087
INSTRUCTION MANUAL	HIM-13010
ASSEMBLY MANUAL	ASM-13003
APPEARANCE CRITERIA No.	QLS-A***

ANGLE	$\pm 2^\circ$	6 OVER 30 MAX.	± 0.3	PROJECTION 	SERIES No. R0	CUSTOMER COPY	
6 MAX.	± 0.2	30 OVER 120 MAX.	± 0.5				
GENERAL TOLERANCE.				TITLE CABLINE® -VSF PLUG SHELL ASS'Y	SCALE	I-PEX	
DWG.	DATE						
CHK.							
APP.							
DWG. No.	20645			UNIT mm	SIZE A3	SHEET 3/6	REV. 12

POS.	D	E	F	G
30	14.50	15.30	17.20	15.00
40	19.50	20.30	22.20	20.00

RECOMMENDED FPC LAYOUT 【SHIELDED TYPE】

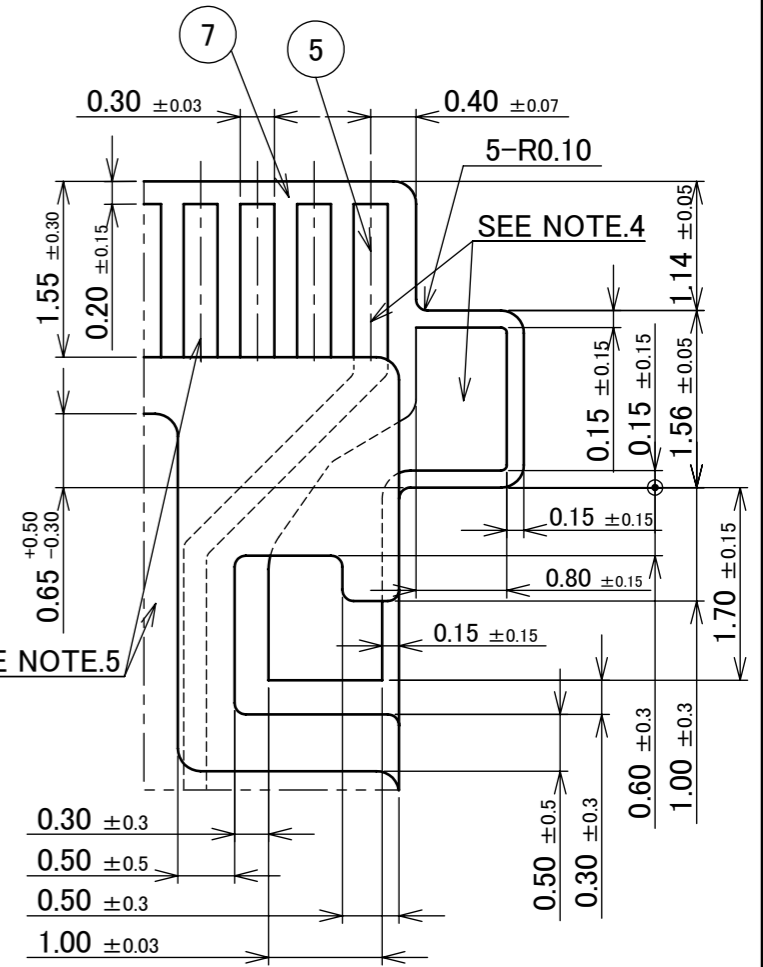
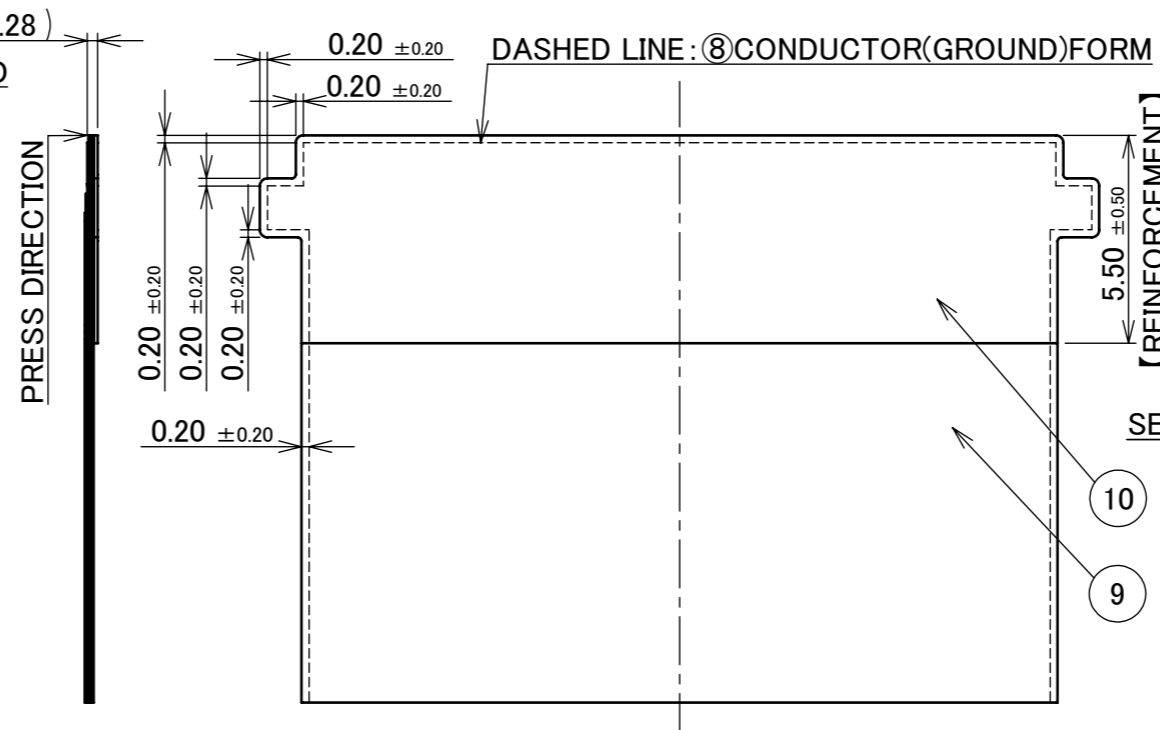
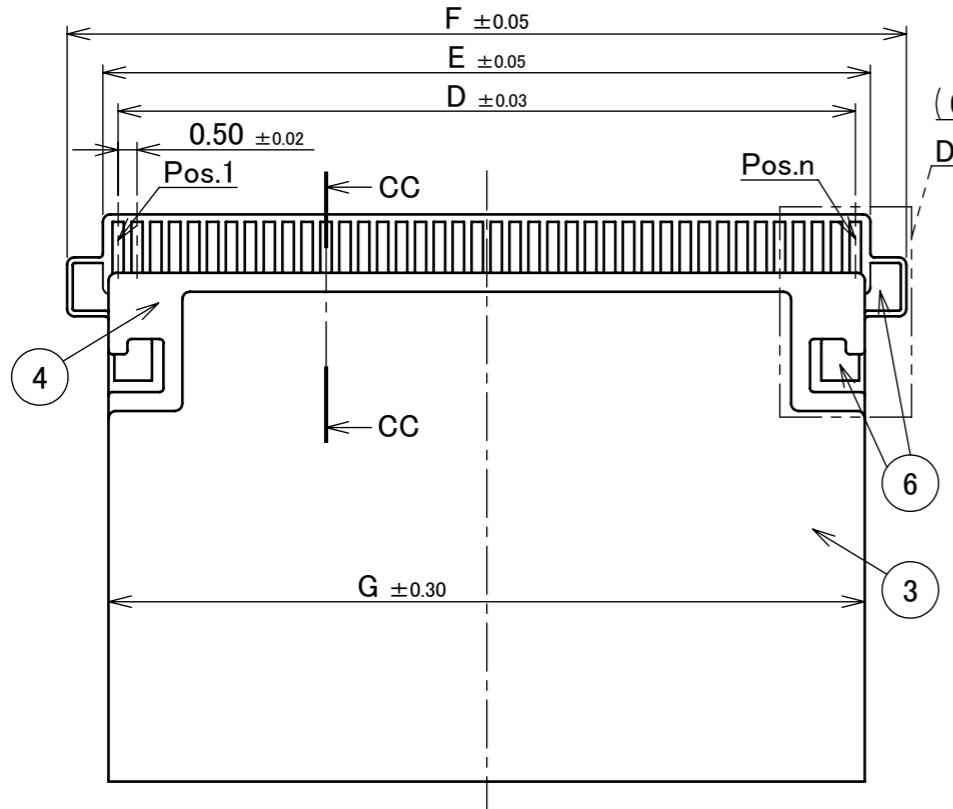

DETAIL DD
(S=15/1)

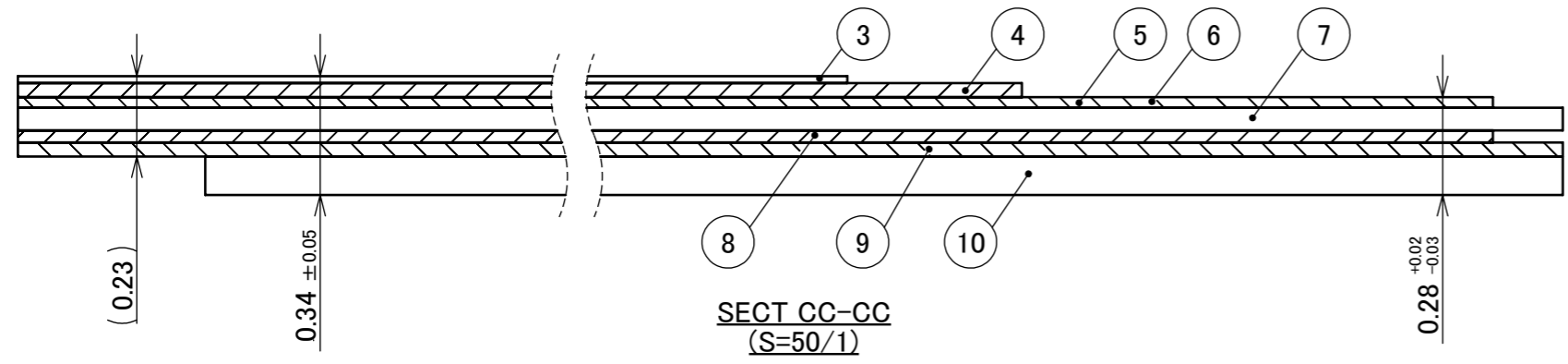

SECT CC-CC
(S=50/1)

10	REINFORCING TAPE	-	-
9	INSULATOR	-	-
8	CONDUCTOR (GROUND)	Cu	-
7	INSULATOR	-	-
6	CONDUCTOR (GROUND)	Cu	Ni, Au
5	CONDUCTOR (SIGNAL)	Cu	Ni, Au
4	INSULATOR	-	-
3	SHIELD FILM	-	-
NO.	DESCRIPTION	MATERIAL	PLATING

- NOTES.
- ADHESIVE SHOULD USE THERMOSETTING.
 - No.6: CONDUCTOR(GROUND) AND No.8: CONDUCTOR(GROUND) ARE CARRYING OUT THE ELECTRICAL CONNECTION.
 - No.3: SHIELD FILM AND No.8: CONDUCTOR(GROUND) ARE CARRYING OUT THE ELECTRICAL CONNECTION.
 - No.5: CONDUCTOR(SIGNAL) AND No.6,8: CONDUCTOR(GROUND) ARE NOT CONTACTING.
 - No.5: CONDUCTOR(SIGNAL) AND No.3: SHIELD FILM ARE NOT CONTACTING.

ANGLE	±2°	6 OVER 30 MAX.	±0.3	PROJECTION 	SERIES No. R0	CUSTOMER COPY		
6 MAX.	±0.2	30 OVER 120 MAX.	±0.5			TITLE CABLIN® -VSF PLUG SHELL ASS'Y	SCALE 5:1	I-PEX
GENERAL TOLERANCE.		DWG.	DATE	DWG. No. 20645	UNIT mm	SIZE A3	SHEET 4/6	
CHK.	APP.							

POS.	D	E	F	G
30	14.50	15.30	17.20	15.00
40	19.50	20.30	22.20	20.00

RECOMMENDED FPC LAYOUT
【NON SHIELDED TYPE】

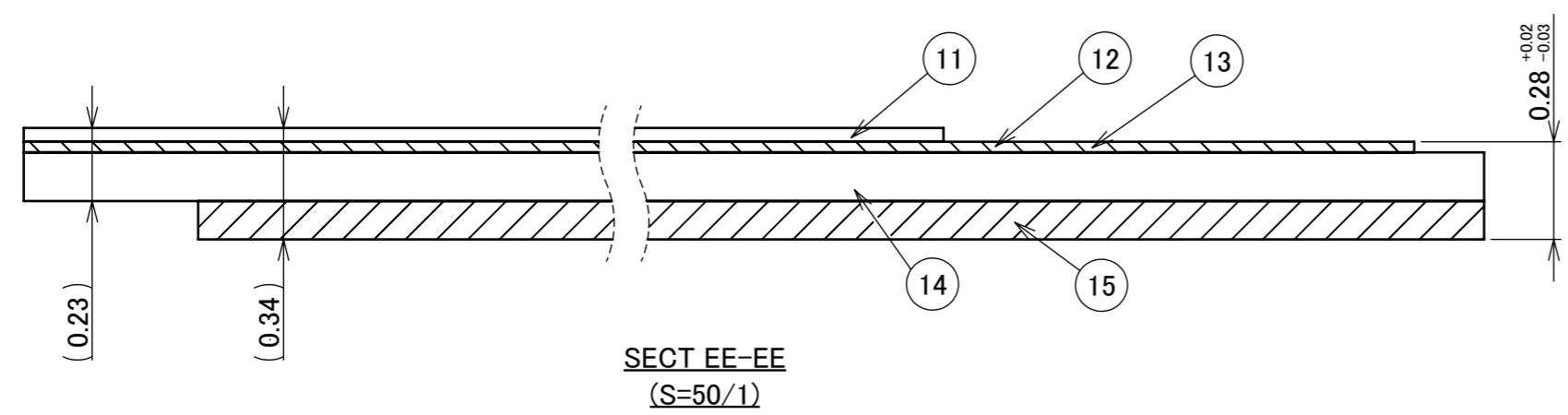
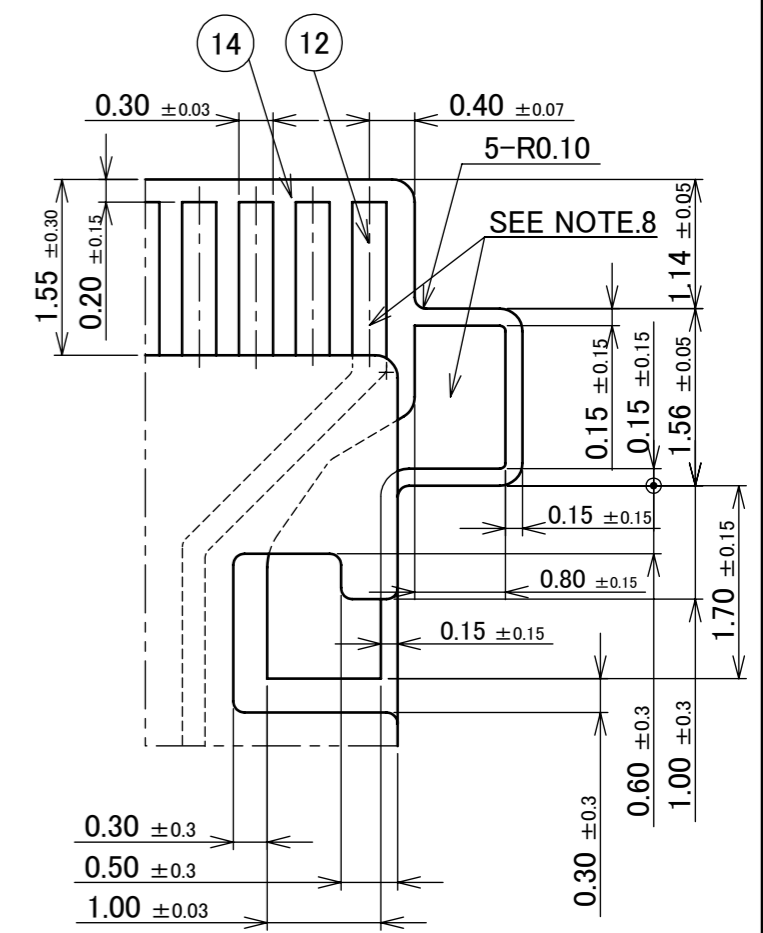
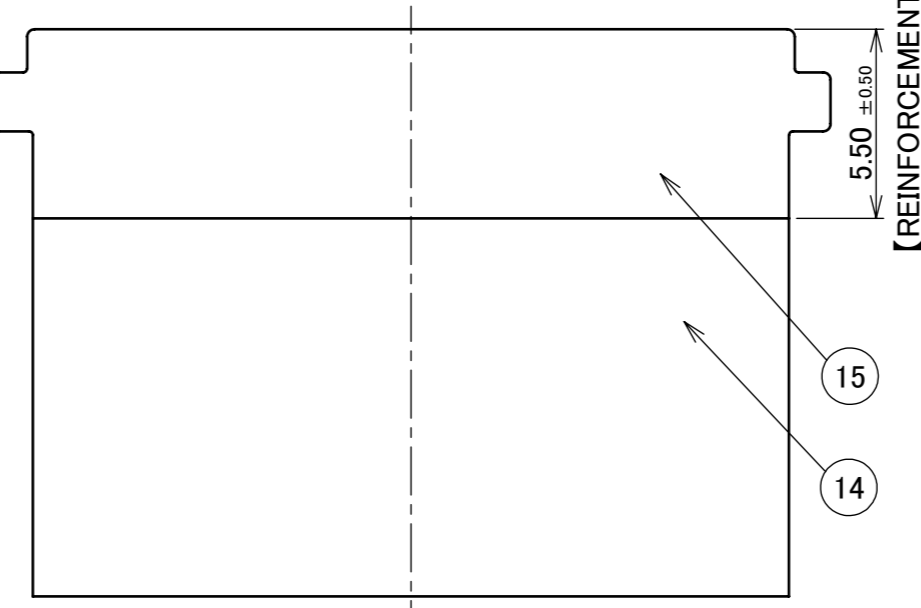
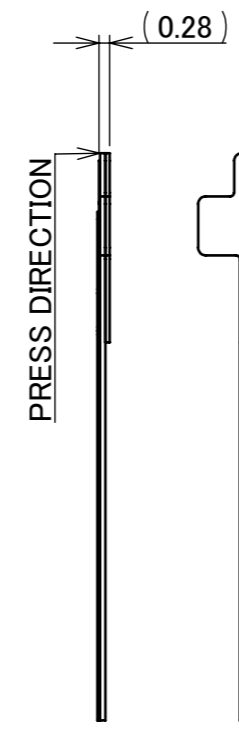
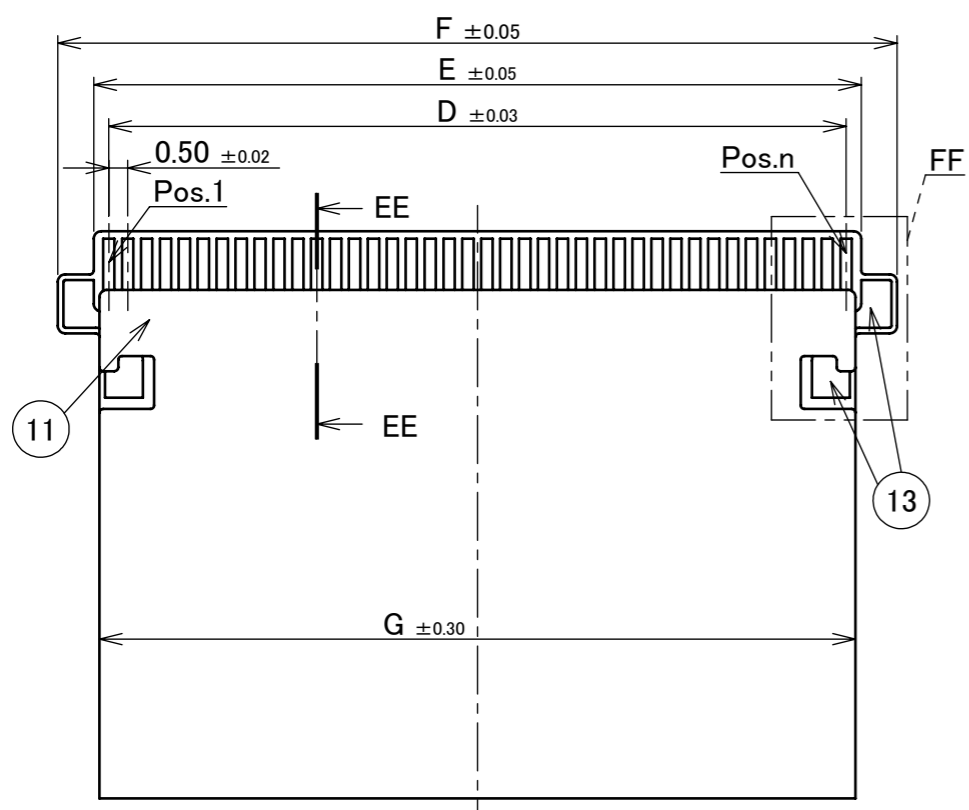

NO.	DESCRIPTION	MATERIAL	PLATING
15	REINFORCING TAPE	-	-
14	INSULATOR	-	-
13	CONDUCTOR (GROUND)	Cu	Ni, Au
12	CONDUCTOR (SIGNAL)	Cu	Ni, Au
11	INSULATOR	-	-

NOTES.
 6. ADHESIVE SHOULD USE THERMOSETTING.
 7. No.12: CONDUCTOR(SIGNAL) AND No.13: CONDUCTOR(GROUND) ARE NOT CONTACTING.

ANGLE	$\pm 2^\circ$	6 OVER 30 MAX.	± 0.3	PROJECTION 	SERIES No. R0	CUSTOMER COPY					
6 MAX.	± 0.2	30 OVER 120 MAX.	± 0.5								
GENERAL TOLERANCE.				TITLE CABLIN [®] -VSF PLUG SHELL ASS'Y	SCALE 5:1	I-PEX					
DWG.	DATE								UNIT mm		
CHK.									SIZE	SHEET	REV.
APP.									A3	5/6	12
				DWG. No.	20645						

PART NO.	QTY. IN DITCH (PIECES / DITCH)	QTY. IN TRAY (PIECES / TRAY)	QTY. PER SHIPPING CARTON (TRAYS / S CARTON)	QTY. PER PACKING CARTON (S CARTON / P CARTON)
20645-030T-01	1	100	20 / S CARTON =2000	4 / P CARTON = 8000
20645-040T-01				

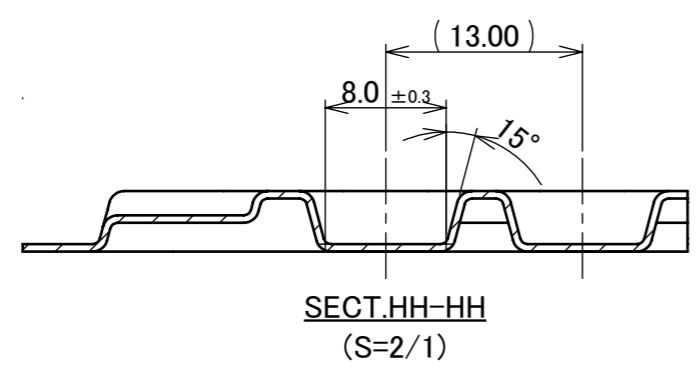
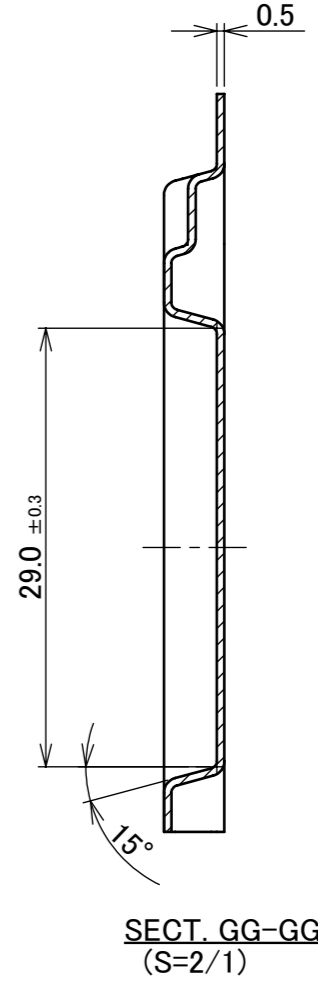
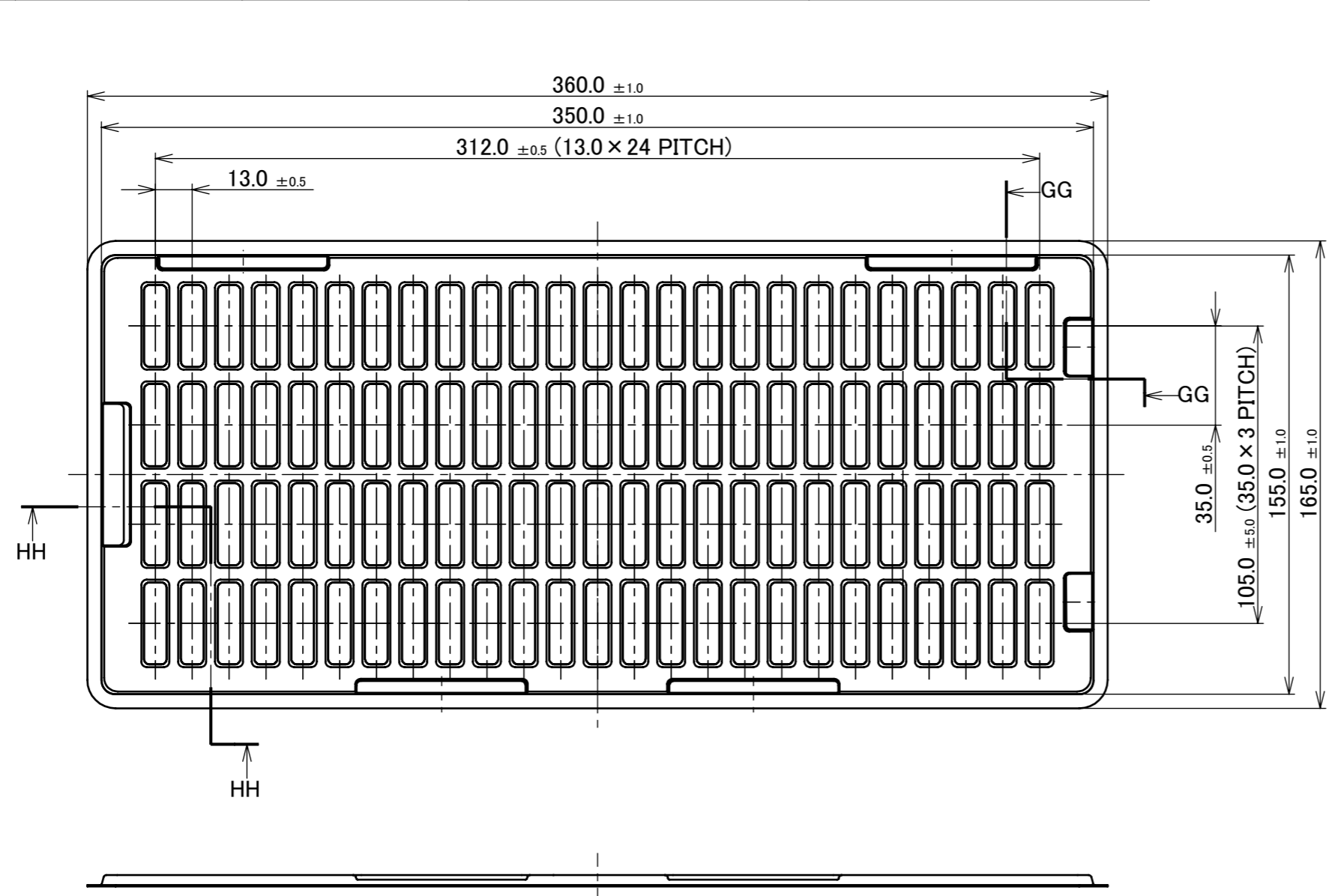

16	TRAY	PP	ANTI-STATIC TYPE
NO.	DISCRIPTION	MATERIAL	FINISH , REMARKS

ANGLE	±2°	6 OVER 30 MAX.	±0.3	PROJECTION ⊕	SERIES No. R0	CUSTOMER COPY		
6 MAX.	±0.2	30 OVER 120 MAX.	±0.5					
GENERAL TOLERANCE.				TITLE CABLIN® -VSF PLUG SHELL ASS'Y	SCALE 10:1	UNIT I-PEX		
DWG.	DATE							
CHK.								
APP.								
				DWG. No.	20645	SIZE A3	SHEET 6/6	REV. 12