

PART NO.	STRUCTURE
91580-0**B-001	MAIN BOARD A ASSEMBLY: 1PC. MAIN BOARD B ASSEMBLY: 1PC. 2xTHRU BOARD ASSEMBLY: 1PC.

P/N : 91580-0 ** B-001
Pos. : 30, 40, 50, 60, 70

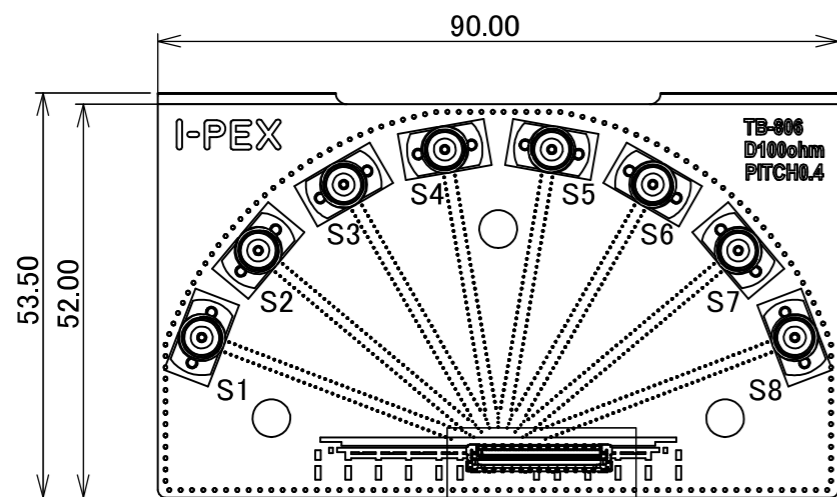

MAIN BOARD A

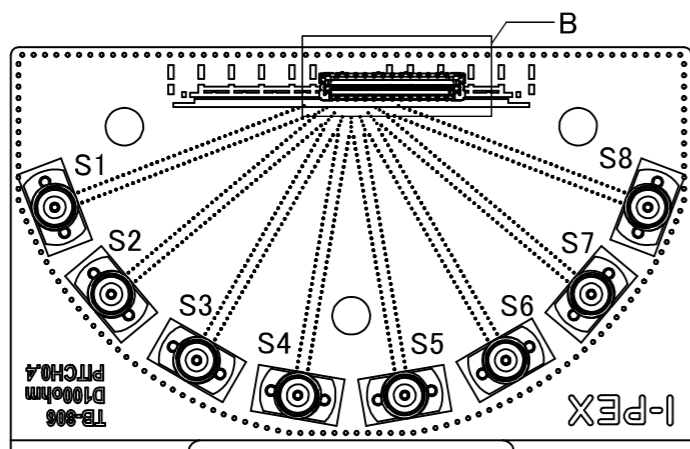

MAIN BOARD B

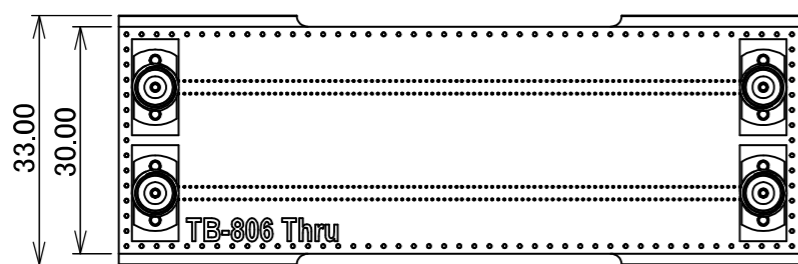

2xTHRU BOARD

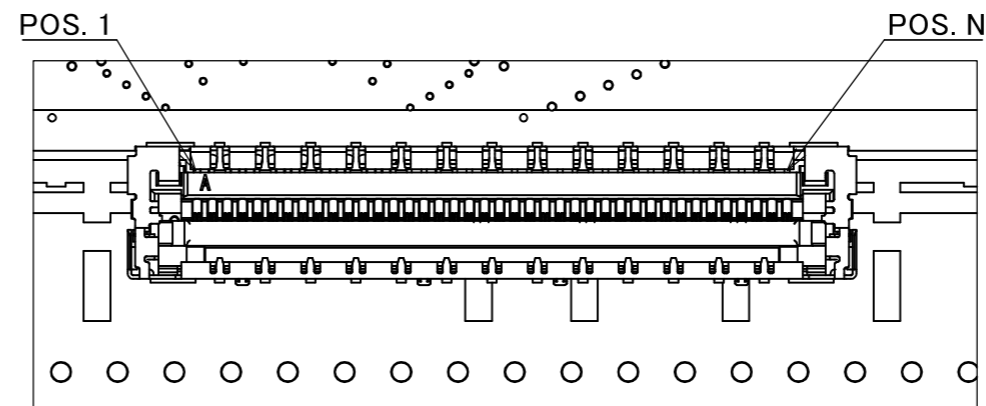

DETAIL A
(S=5/1)

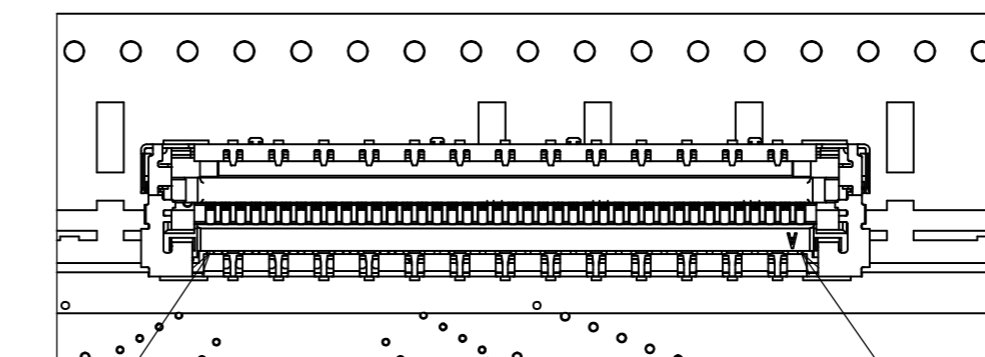

DETAIL B
(S=5/1)

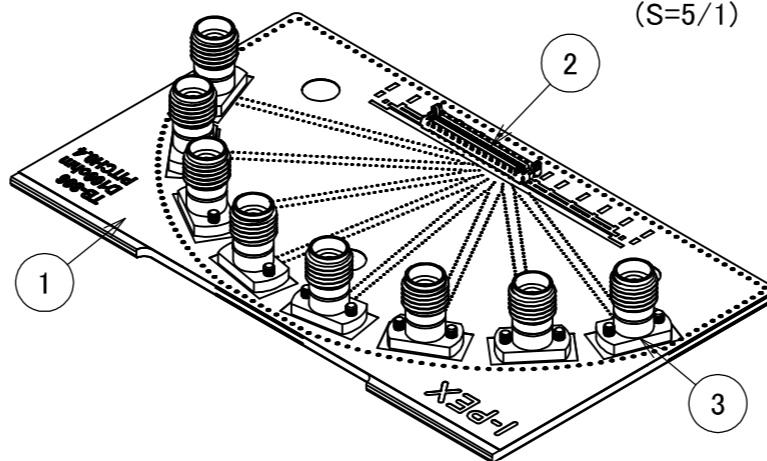

MAIN BOARD A/B ASSEMBLY

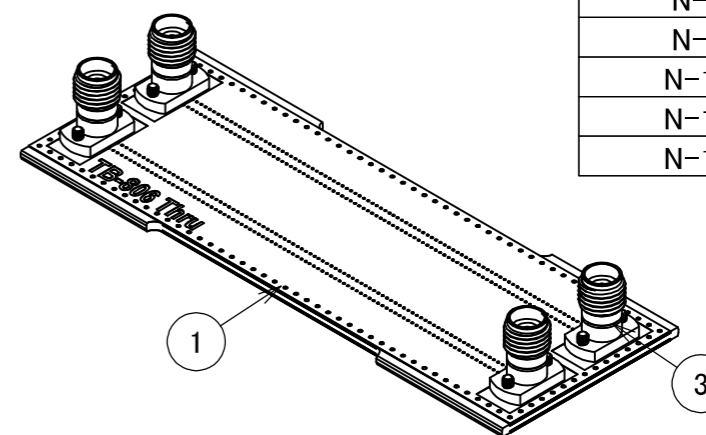

2xTHRU BOARD ASSEMBLY

MAIN BOARD A	
PIN POS.	ASSIGNMENT
1	GND
2	S1
3	S2
4	GND
5	S3
6	S4
7	GND
8	S5
9	S6
10	GND
11	S7
12	S8
13	GND

MAIN BOARD B	
PIN POS.	ASSIGNMENT
N	GND
N-1	S1
N-2	S2
N-3	GND
N-4	S3
N-5	S4
N-6	GND
N-7	S5
N-8	S6
N-9	GND
N-10	S7
N-11	S8
N-12	GND

NO.	DESCRIPTION	PART NO.	QTY	REMARKS
3	2.92mm CONNECTOR	50104-J001	20	JACK
2	CONNECTOR	20879-0**E-01	2	CABLINÉ-UM RECEPTACLE
1	TEST BOARD	TB-806	1	TEST BOARD THICKNESS : 1.6mm

NOTES.

- FOR DETAILED INFORMATION ON THE STRUCTURE OF TEST BOARD TB-806, REFER TO REPORT #IER-001-10697.
- CHARACTERISTIC IMPEDANCE : 50Ω ± 10% (SINGLE-ENDED). Tr=17.5ps (10%-90%)
- APPLICABLE PLUG CONNECTOR : CABLINE-UM PLUG (P/N : 20877-0**T-##)
- MAXIMUM MEASUREMENT FREQUENCY : 40GHz
- OTHER PIN CONFIGURATIONS CAN BE PROVIDED UPON REQUEST.

REVISION RECORD					GENERAL TOLERANCE.			PROJECTION		SERIES No.		CUSTOMER COPY	
REV.	ECN	BY	DATE	APP.	ANGLE	±2°	6 OVER 30 MAX.	±0.3	TITLE	SCALE	UNIT	SHEET	REV.
1	ZC00710	R.M	2026/05/25	H.I	6 MAX.	±0.2	30 OVER 120 MAX.	±0.5					
0	Z241156	H.U	2024/08/29	-	DWG. H.Uchida DATE 2024/08/29			DWG. No. 91580					
T.Masunaga					M.Nakamura			DWG. No. 91580		A3		1	

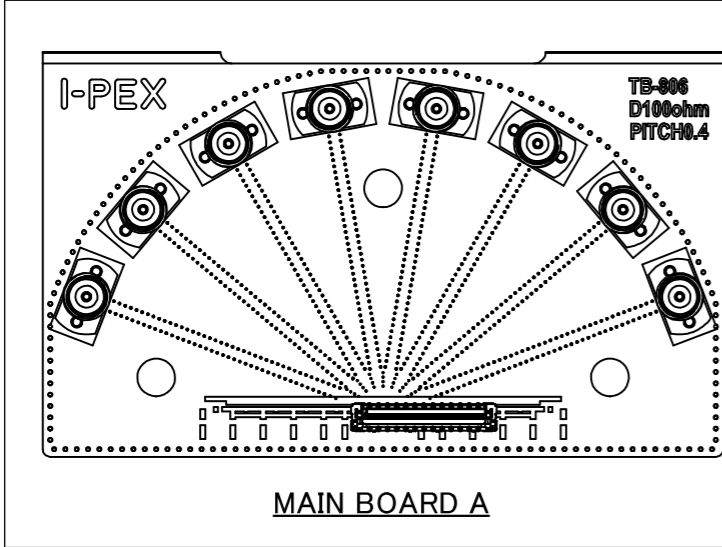

<LARGE BAG>
REUSABLE PLASTIC BAG

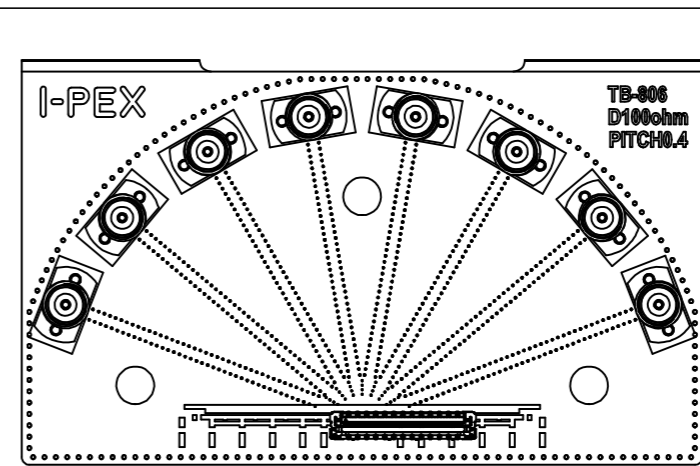

<SMALL BAG>
REUSABLE PLASTIC BAG

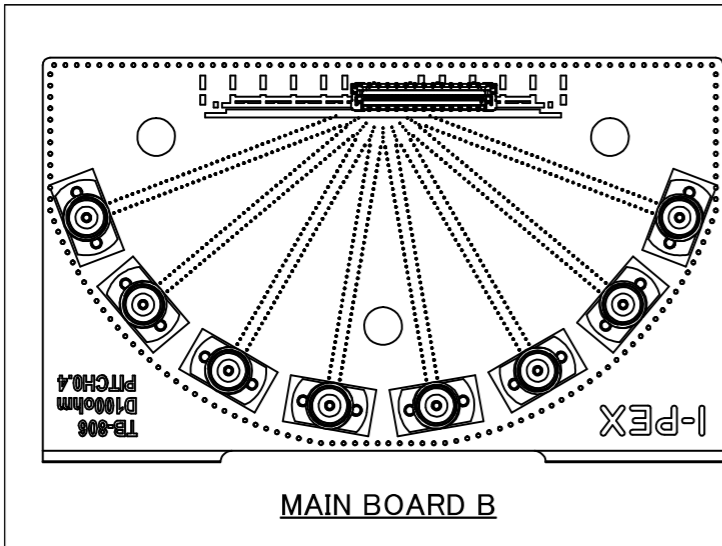

<SMALL BAG>
REUSABLE PLASTIC BAG

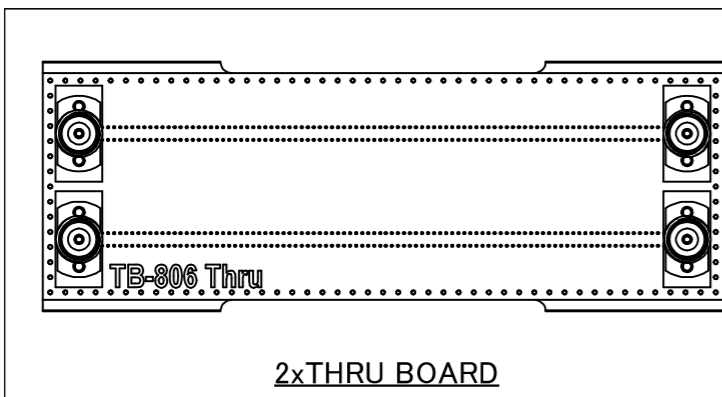
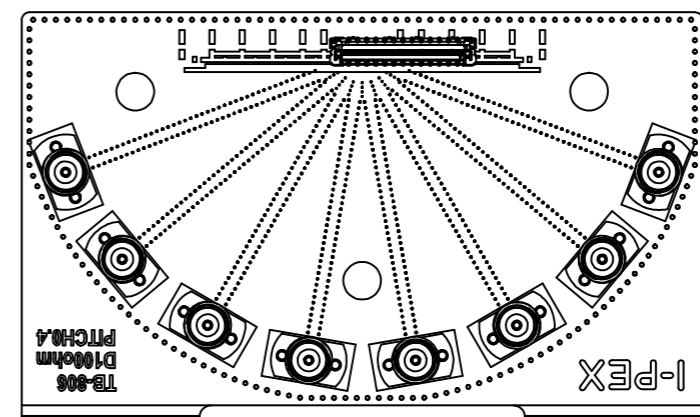

<SMALL BAG>
REUSABLE PLASTIC BAG

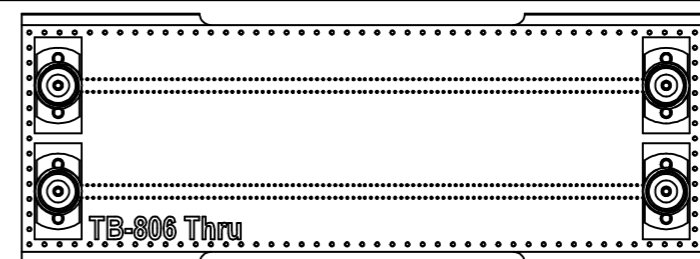

PACKING STYLE

ANGLE	±2°	6 OVER 30 MAX.	±0.3	PROJECTION ⊕	SERIES No. R1R5R0	CUSTOMER COPY	
	6 MAX.	±0.2	30 OVER 120 MAX.				
GENERAL TOLERANCE.				TITLE CABLIN [®] -UM SI TEST BOARD ASSEMBLY	DWG. No. 91580	SCALE	I-PEX
DWG.	DATE		1:2				
CHK.			UNIT				
APP.			mm				
				SIZE	SHEET	REV.	
				A3	2/2	1	