

Recommended P/N 3488-0\*\*1

| PART No.  | Pos. | A     | B     | C     | D     | E     |
|-----------|------|-------|-------|-------|-------|-------|
| 3488-0301 | 30   | 16.20 | 13.88 | 4.00  | 13.65 | 9.36  |
| 3488-0401 | 40   | 20.20 | 17.88 | 8.00  | 17.65 | 13.36 |
| 3588-0501 | 50   | 24.20 | 21.88 | 12.00 | 21.65 | 17.36 |
| 3488-0601 | 60   | 28.20 | 25.88 | 16.00 | 25.65 | 21.36 |



Halogen Free RoHS Compliant

**PATENT PENDING**

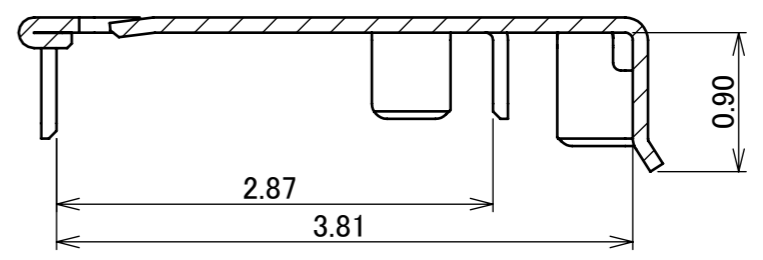
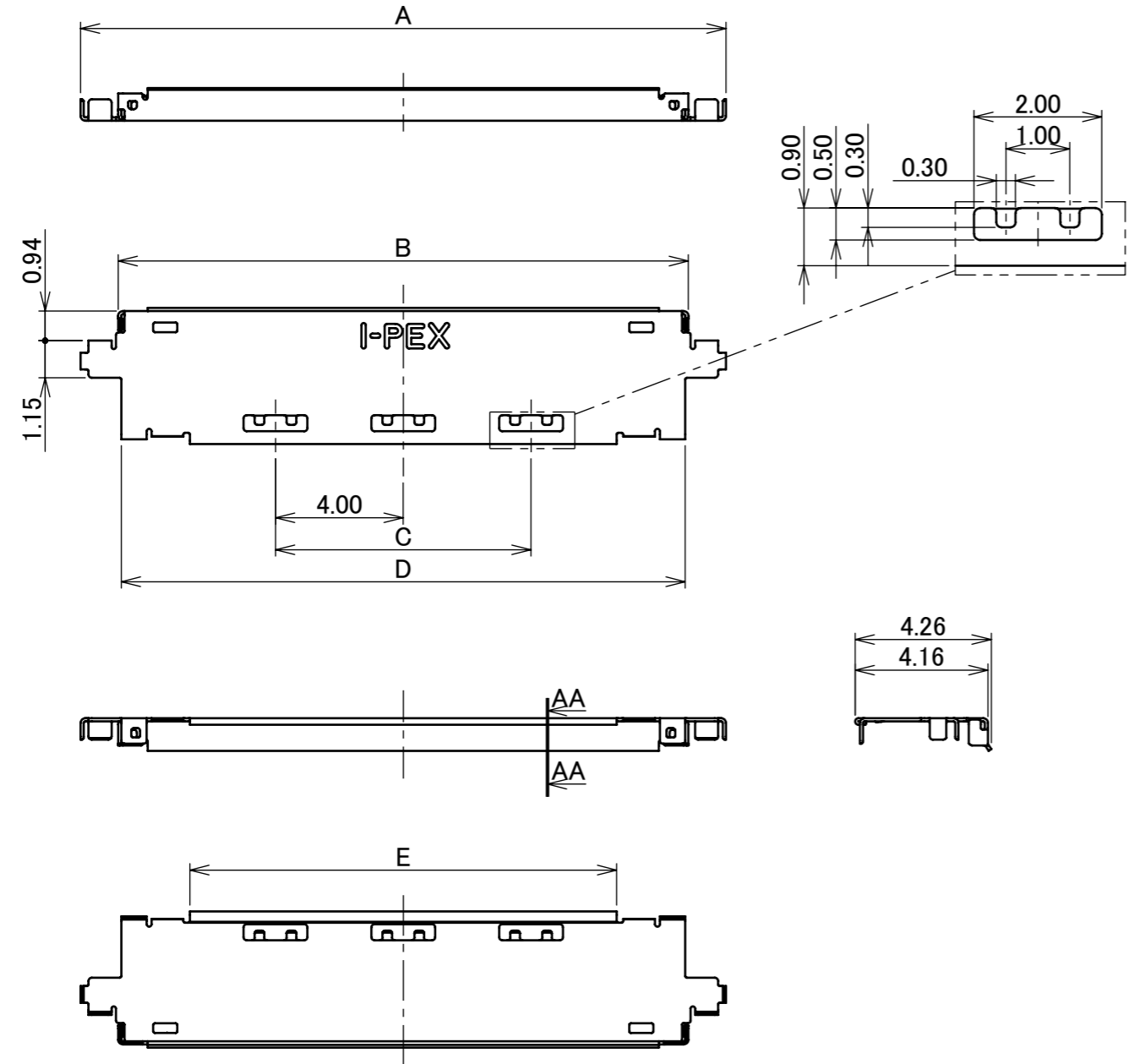
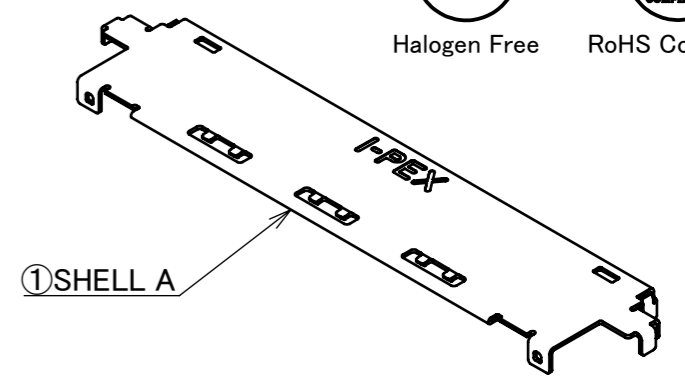

SECT.AA-AA (S=20/1)

| NO. | DISCRIPTION | MATERIAL        | FINISH , REMARKS                                |
|-----|-------------|-----------------|---|
| 1   | SHELL A     | PHOSPHOR BRONZE | PARTIAL Au 0.003 μ m MIN. OVER Ni 1.00 μ m MIN. |

| REV.            | ECN     | BY  | DATE        | APP. | APP.    | ANGLE              | ±2°  | 6 OVER 30 MAX.   | ±0.3 | PROJECTION               | SERIES No. | CUSTOMER COPY  |
|-----------------|---------|-----|-------------|------|---------|--------------------|------|------------------|------|--------------------------|------------|--|
| 3               | Z240289 | R.M | Mar./05/'24 | T.M  |         | 6 MAX.             | ±0.2 | 30 OVER 120 MAX. | ±0.5 | ⊕                        | R2         | TITLE<br>CABLINE® -UM<br>PLUG SHELL A<br><br>SCALE<br>5:1<br>UNIT<br>mm<br>SIZE SHEET<br>A3 1/2<br>REV.<br>3 |
| 2               | Z211301 | T.M | Nov./01/'21 | H.I  | DWG.    | GENERAL TOLERANCE. |      |                  |      | T.Masunaga<br>2019/01/10 |            |  |
| 1               | Z200040 | T.M | Jan./14/'20 | H.I  | CHK.    |                    |      |                  |      |                          |            |  |
| 0               | Z190029 | T.M | Jan./10/'19 |      | APP.    |                    |      |                  |      |                          |            |  |
| REVISION RECORD |         |     |             |      | H.Ikari | DWG. No.           | 3488 |                  |      |                          |            |  |

| PART No.  | Pos. | F     | G     | QTY. PER EMBOSS REEL<br>(PIECES / REEL) | QTY. PER PACKING CARTON<br>(REELS / CARTON) | PACKING STANDARD |
|-----------|------|-------|-------|---|---|------------------|
| 3488-0301 | 30   | 40.00 | 37.00 | 5000 / REEL                             | 3 / CARTON = 15000                          | PST-18045        |
| 3488-0401 | 40   | 40.00 | 37.00 |   |   |                  |
| 3488-0501 | 50   | 40.00 | 37.00 |   |   |                  |
| 3488-0601 | 60   | 40.00 | 37.00 |   |   |                  |

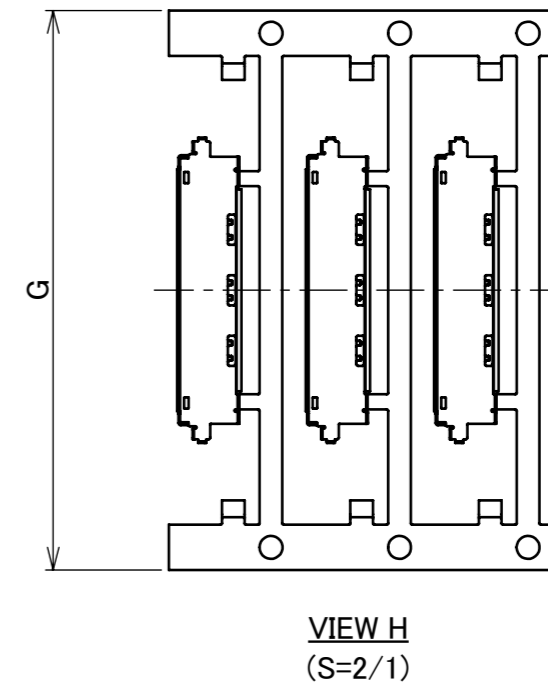
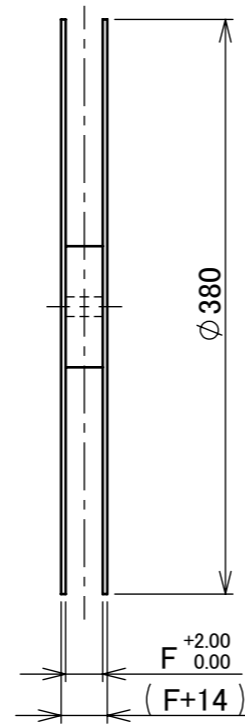
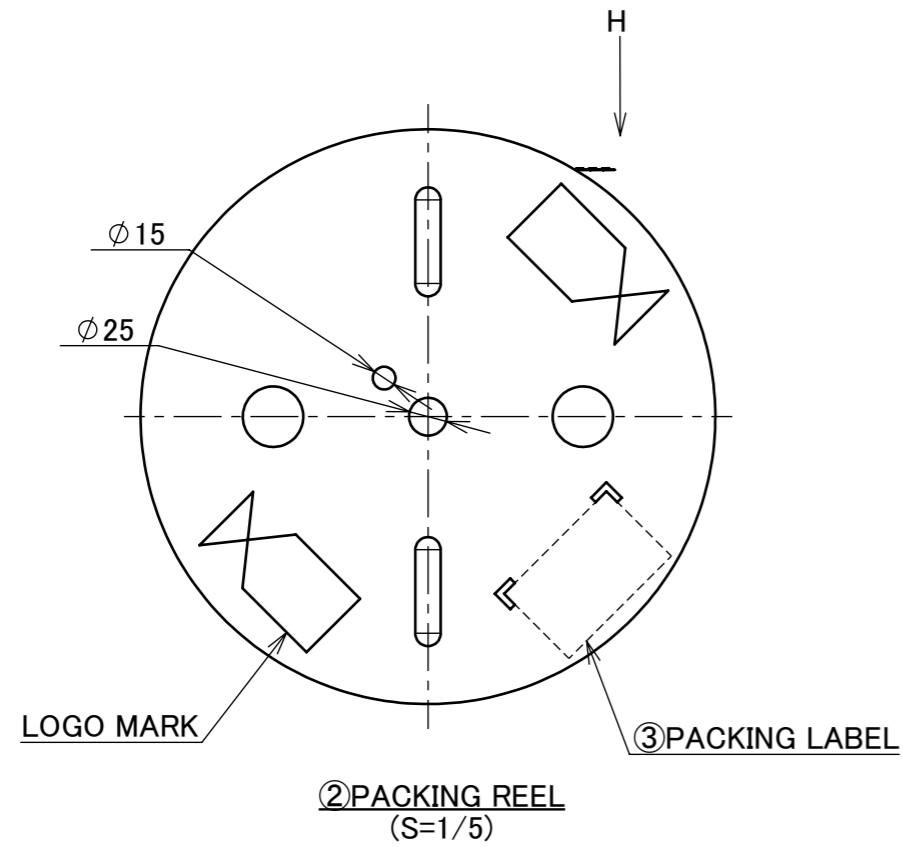

| NO. | DISCRIPTION   | MATERIAL  | FINISH , REMARKS |
|-----|---------------|-----------|------------------|
| 3   | PACKING LABEL | -         | -                |
| 2   | PACKING REEL  | CARDBOARD | -                |

| ANGLE              | $\pm 2^\circ$ | 6 OVER 30 MAX.   | $\pm 0.3$ | PROJECTION                  | SERIES No. | CUSTOMER COPY |       |       |      |
|--------------------|---------------|------------------|-----------|-----------------------------|------------|---------------|-------|-------|------|
| 6 MAX.             | $\pm 0.2$     | 30 OVER 120 MAX. | $\pm 0.5$ |                             | R2         | I-PEX         |       |       |      |
| GENERAL TOLERANCE. |               |                  |           | TITLE                       |            | SCALE         | I-PEX |       |      |
| DWG.               | DATE          |                  |           | CABLIN® -UM<br>PLUG SHELL A |            | 5:1           |       |       |      |
| CHK.               |               |                  |           |                             |            | UNIT          |       |       |      |
| APP.               |               |                  |           | DWG. No.                    |            | mm            | SIZE  | SHEET | REV. |
|                    |               |                  |           | 3488                        |            | A3            | 2/2   | 3     |      |