

Recommended P/N 3488-0\*\*1

| PART No.  | Pos. | A     | B     | C     | D     | E     |
|-----------|------|-------|-------|-------|-------|-------|
| 3488-0301 | 30   | 16.20 | 13.88 | 4.00  | 13.65 | 9.36  |
| 3488-0401 | 40   | 20.20 | 17.88 | 8.00  | 17.65 | 13.36 |
| 3488-0601 | 60   | 28.20 | 25.88 | 16.00 | 25.65 | 21.36 |

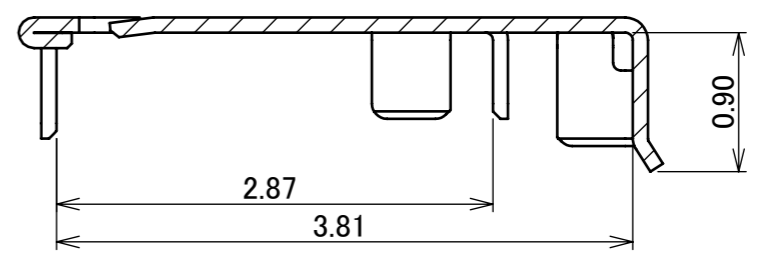

**PATENT PENDING**

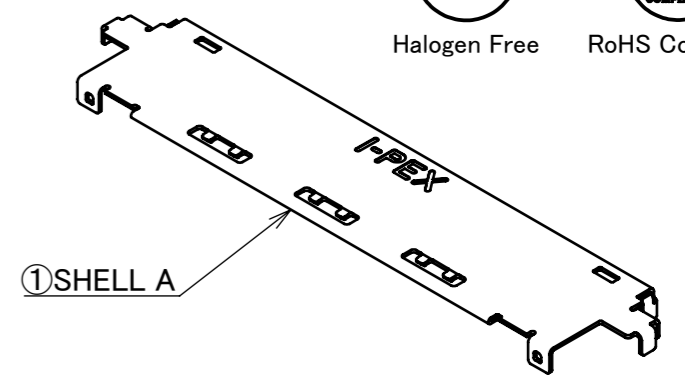
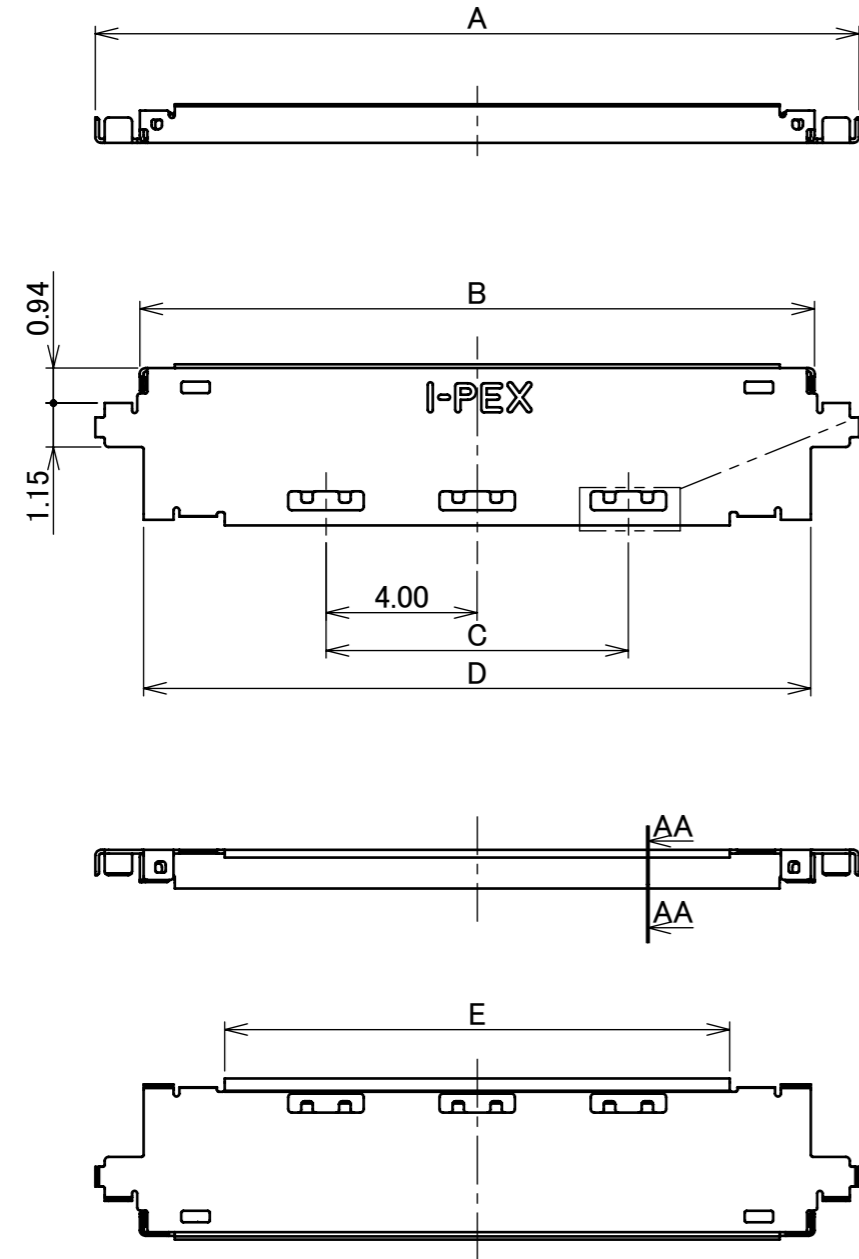

SECT.AA-AA  
(S=20/1)

| NO. | DISCRIPTION | MATERIAL        | FINISH , REMARKS                                |
|-----|-------------|-----------------|---|
| 1   | SHELL A     | PHOSPHOR BRONZE | PARTIAL Au 0.003 μ m MIN. OVER Ni 1.00 μ m MIN. |

| REV. | ECN     | BY  | DATE        | APP. | APP.    | DATE       | DWG. No. | SIZE | SHEET | REV. |
|------|---------|-----|-------------|------|---------|------------|----------|------|-------|------|
| 2    | Z211301 | T.M | Nov./01/'21 | H.I  | H.Ikari | 2019/01/11 | 3488     | A3   | 1/2   | 2    |
| 1    | Z200040 | T.M | Jan./14/'20 | H.I  |         |            |          |      |       |      |
| 0    | Z190029 | T.M | Jan./10/'19 |      |         |            |          |      |       |      |

Confidential C

I-PEX Inc.

QKE-DFE06-02 REV.12

| PART No.  | Pos. | F     | G     | QTY. PER EMBOSS REEL<br>(PIECES / REEL) | QTY. PER PACKING CARTON<br>(REELS / CARTON) | PACKING STANDARD |
|-----------|------|-------|-------|---|---|------------------|
| 3488-0301 | 30   | 40.00 | 37.00 | 5000 / REEL                             | 3 / CARTON = 15000                          | PST-18045        |
| 3488-0401 | 40   | 40.00 | 37.00 |   |   |                  |
| 3488-0601 | 60   | 40.00 | 37.00 |   |   |                  |

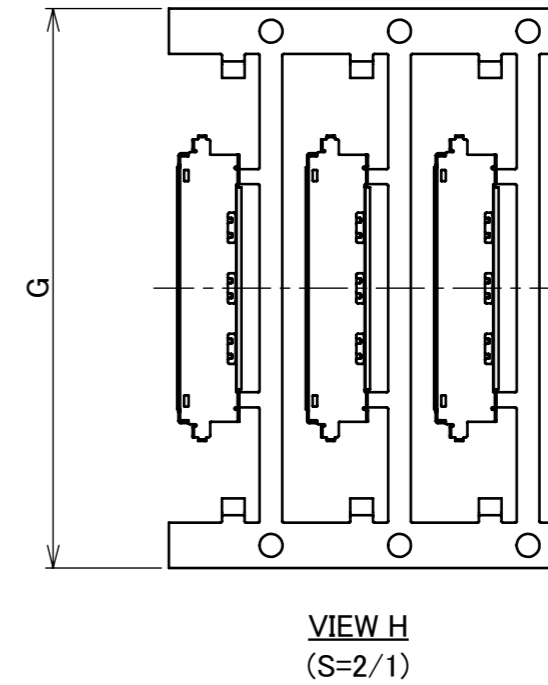
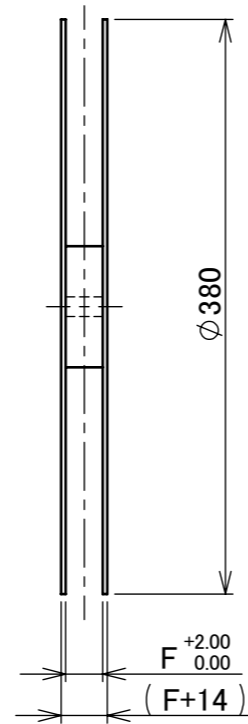
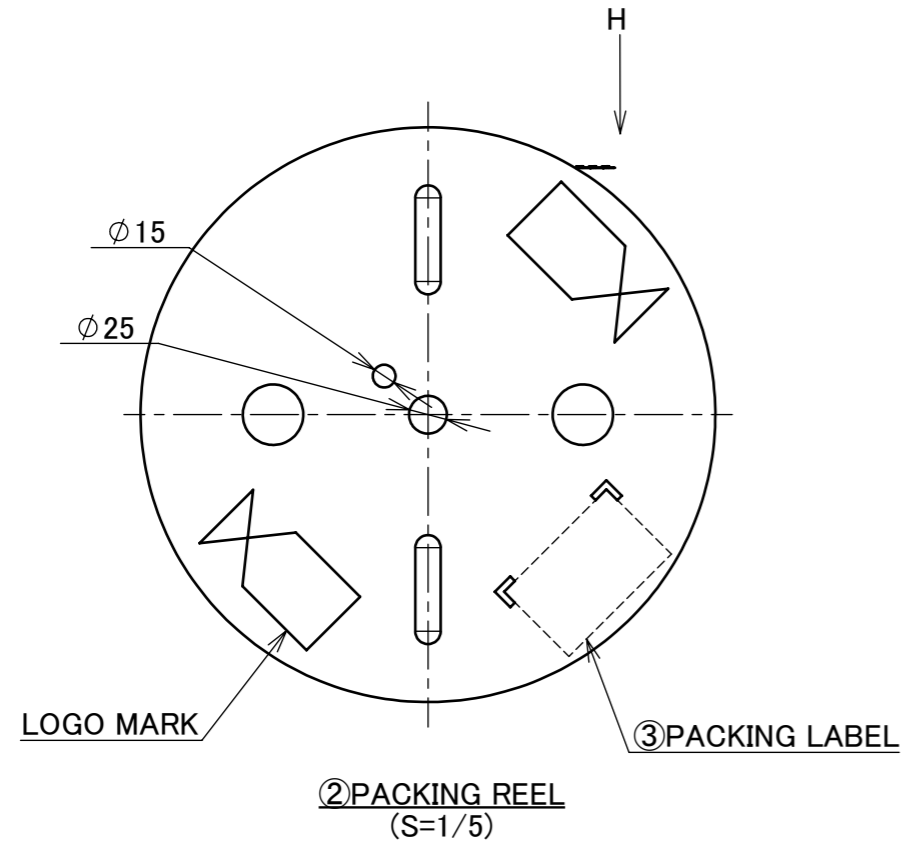

| NO. | DISCRIPTION   | MATERIAL  | FINISH , REMARKS |
|-----|---------------|-----------|------------------|
| 3   | PACKING LABEL | -         | -                |
| 2   | PACKING REEL  | CARDBOARD | -                |

| ANGLE              | $\pm 2^\circ$ | 6 OVER 30 MAX.   | $\pm 0.3$ | PROJECTION                              | SERIES No. | CUSTOMER COPY   |  |  |      |       |      |
|--------------------|---------------|------------------|-----------|---|------------|---|--|--|------|-------|------|
| 6 MAX.             | $\pm 0.2$     | 30 OVER 120 MAX. | $\pm 0.5$ |   | R2         | <div style="display: flex; align-items: center;"> <div style="margin-right: 10px;">SCALE</div> <div style="font-size: 24px; font-weight: bold;">5:1</div> </div> <div style="display: flex; align-items: center;"> <div style="margin-right: 10px;">UNIT</div> <div style="font-size: 24px; font-weight: bold;">mm</div> </div> <div style="display: flex; align-items: center;"> <div style="margin-right: 10px;">I-PEX</div> </div> |  |  |      |       |      |
| GENERAL TOLERANCE. |               |                  |           | TITLE                                   |            |   |  |  | SIZE | SHEET | REV. |
| DWG.               | DATE          |                  |           | CABLIN <sup>®</sup> -UM<br>PLUG SHELL A |            |   |  |  | A3   | 2/2   | 2    |
| CHK.               |               |                  |           |   |            |   |  |  |      |       |      |
| APP.               |               |                  |           | DWG. No.                                |            | 3488  |  |  |      |       |      |