

Recommended P/N 20877-0**T-01

PART NO.	Pos.	A	B	C	D	E
20877-030T-01	30	16.20	13.85	13.65	11.60	17.00
20877-040T-01	40	20.20	17.85	17.65	15.60	21.00
20877-060T-01	60	28.20	25.85	25.65	23.60	29.00

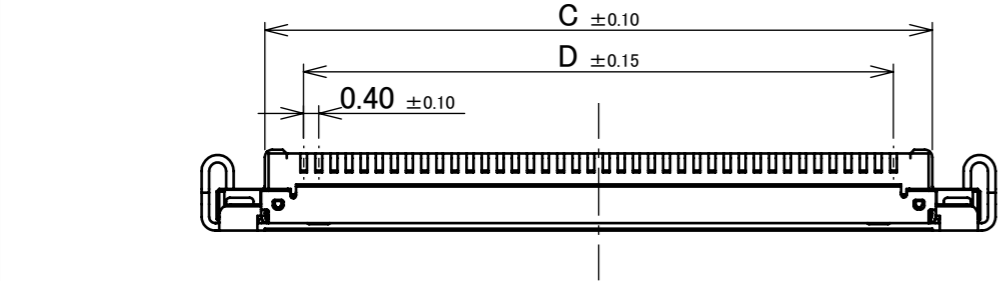

With LOCK COVER

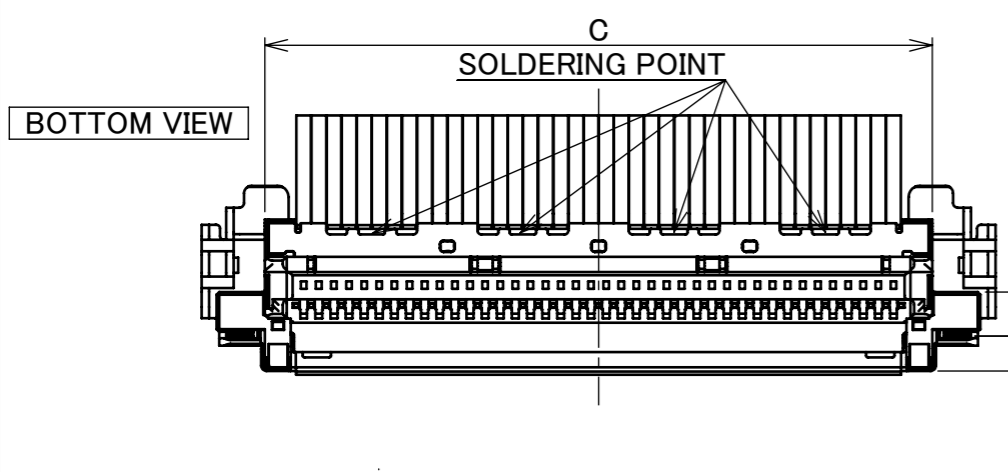
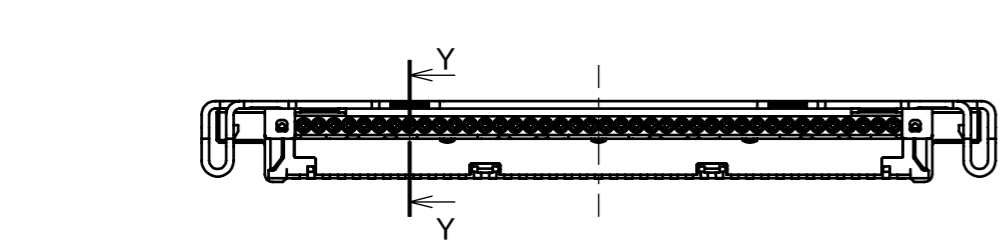
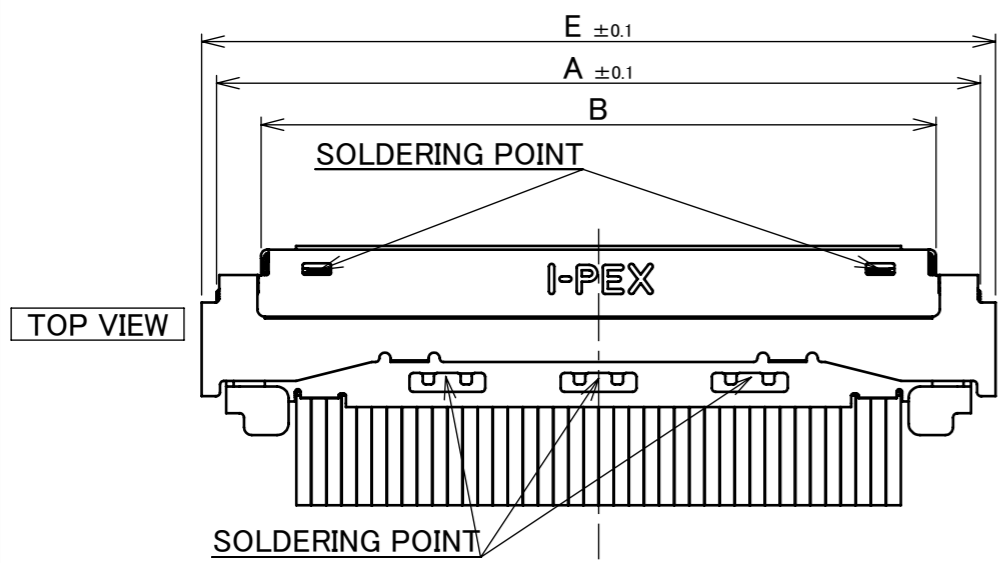

BONDING
(LOCTITE 352 RECOMMENDS)

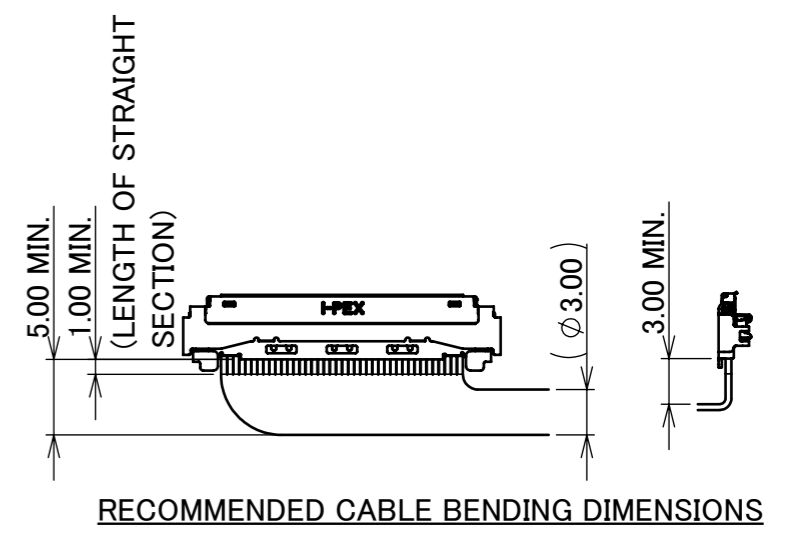
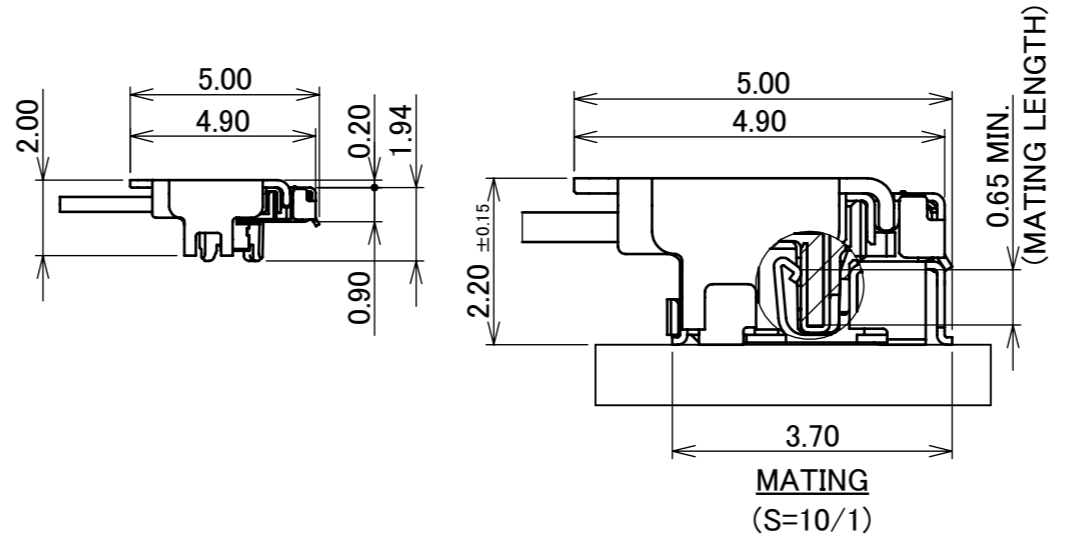
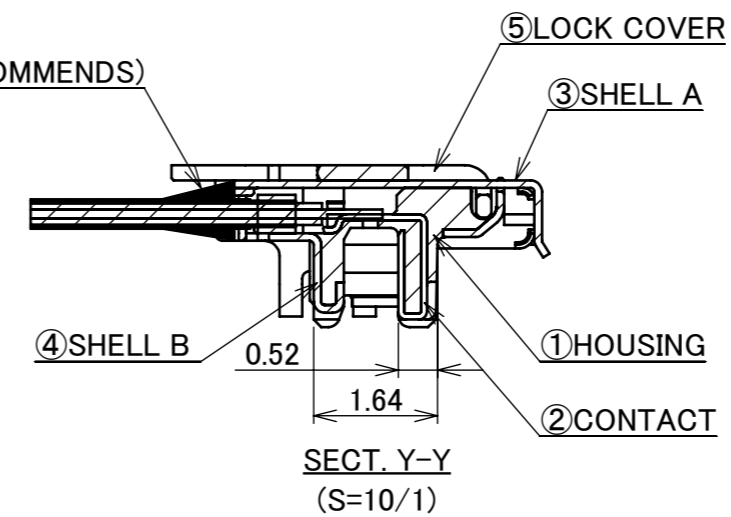

PATENT PENDING

NO.	DISCRIPTION	MATERIAL	FINISH , REMARKS
5	LOCK COVER	PHOSPHOR BRONZE	ALL OVER Ni 1.0 μ m MIN.
4	SHELL B	PHOSPHOR BRONZE	PARTIAL Au 0.003 μ m MIN. OVER Ni 1.0 μ m MIN.
3	SHELL A	PHOSPHOR BRONZE	PARTIAL Au 0.003 μ m MIN. OVER Ni 1.0 μ m MIN.
2	CONTACT	CORSON ALLOY	ALL OVER Ni 1.0 μ m MIN. CONTACT & SOLDERING AREA : Au 0.03 μ m MIN.
1	HOUSING	LCP	UL94V-0 ,BLACK

REV.	ECN	BY	DATE	APP.	APP.	REVISION RECORD	PROJECTION	SERIES No.	TITLE	SCALE	SHEET	REV.
12	Z240414	T.Ono	Apr./04/'24	T.M	ANGLE ±2°	6 OVER 30 MAX. ±0.3		R3R2R2R0	CABLINER-UM PLUG CABLE ASSEMBLY	5:1	mm	12
11	Z231031	H.U	Sept./13/'23	T.M	6 MAX. ±0.2	30 OVER 120 MAX. ±0.5						
10	Z230612	R.M	May./26/'23	T.M	GENERAL TOLERANCE.			R3R2R2R0	CABLINER-UM PLUG CABLE ASSEMBLY	5:1	mm	12
9	Z230347	R.M	Mar./24/'23	T.M	DWG. T.Masunaga	DATE 2019/01/10						
8	Z230276	R.M	Mar./10/'23	T.M	CHK. -							
7	Z230039	K.B	Jan./13/'23	H.I	APP. H.Ikari							
REVISION RECORD							H.Ikari	DWG. No. 20877		A3	1/5	12

Recommended P/N 20877-0**T-01

PART NO.	Pos.	A	B	C	D
20877-030T-02	30	16.20	13.85	13.65	11.60
20877-040T-02	40	20.20	17.85	17.65	15.60
20877-050T-02	50	24.20	21.85	21.65	19.60
20877-060T-02	60	28.20	25.85	25.65	23.60



Without LOCK COVER

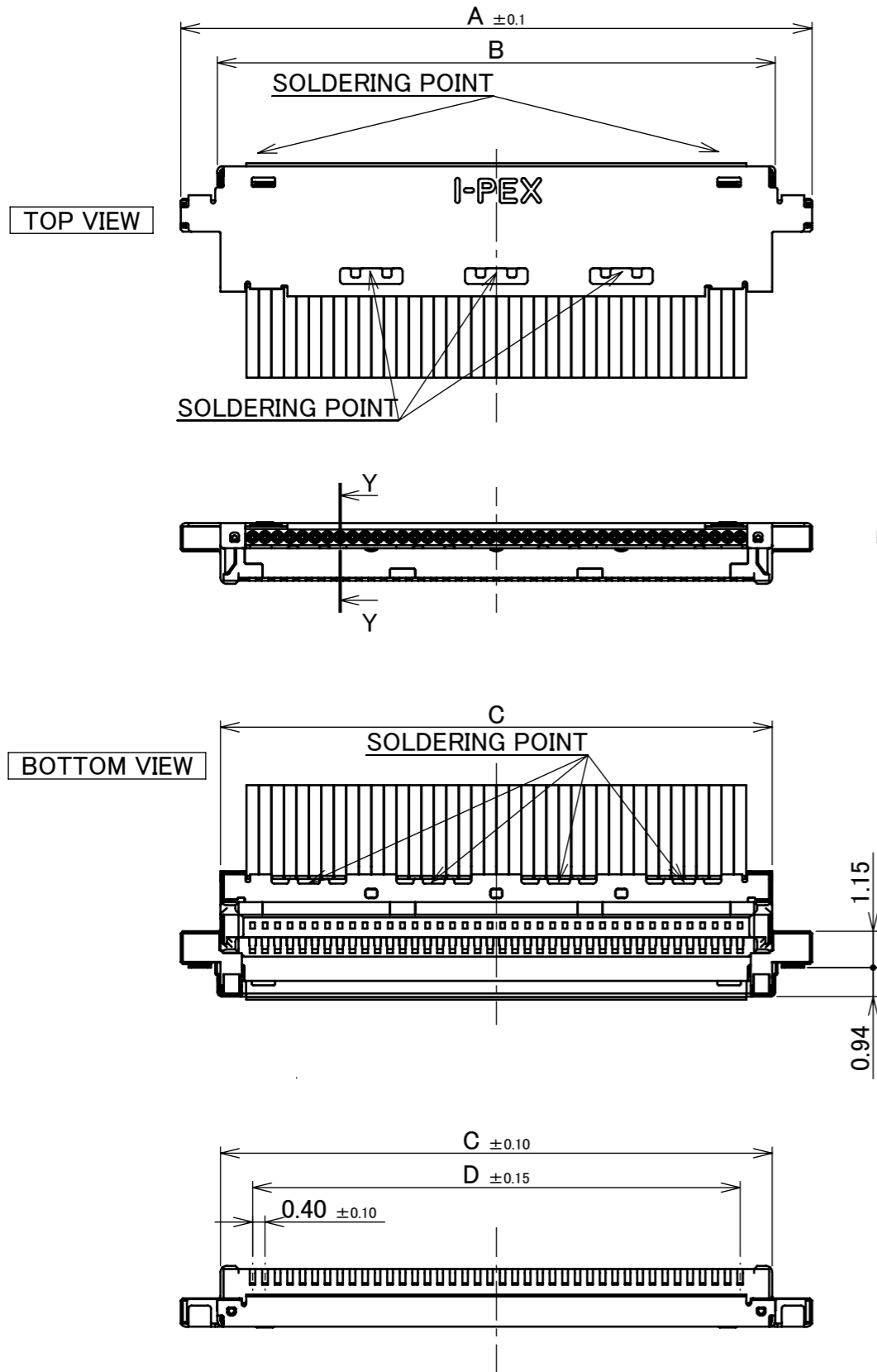

BONDING
(LOCTITE 352 RECOMMENDS)

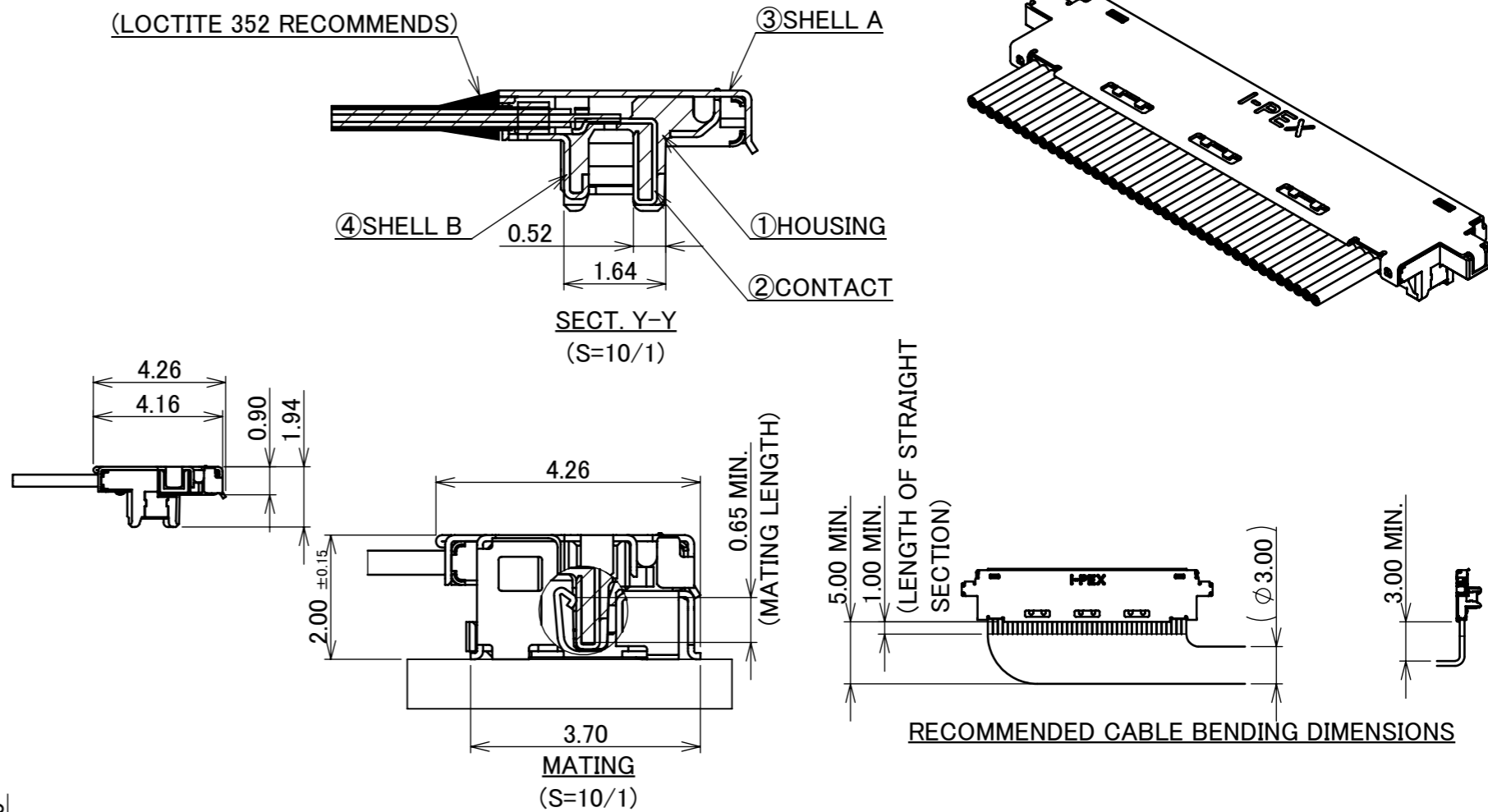

PATENT PENDING

NO.	DISCRIPTION	MATERIAL	FINISH , REMARKS
4	SHELL B	PHOSPHOR BRONZE	PARTIAL Au 0.003 μ m MIN. OVER Ni 1.0 μ m MIN.
3	SHELL A	PHOSPHOR BRONZE	PARTIAL Au 0.003 μ m MIN. OVER Ni 1.0 μ m MIN.
2	CONTACT	CORSON ALLOY	ALL OVER Ni 1.0 μ m MIN. CONTACT & SOLDERING AREA : Au 0.03 μ m MIN.
1	HOUSING	LCP	UL94V-0 ,BLACK

ANGLE	±2°	6 OVER 30 MAX.	±0.3	PROJECTION ⊕	SERIES No. R3R2R2R0	CUSTOMER COPY			
	6 MAX.	±0.2	30 OVER 120 MAX.						±0.5
GENERAL TOLERANCE.					TITLE CABLIN®-UM PLUG CABLE ASSEMBLY	SCALE	I-PEX		
DWG.	DATE					5:1			
CHK.						UNIT			
APP.						mm			
					DWG. No.	20877	SIZE	SHEET	REV.
							A3	2/5	12

Recommended P/N 20877-0**T-01

PART NO.	Pos.	A	B	C	D	F	G
20877-030T-03	30	16.20	13.85	13.65	11.60	9.00	10.00
20877-040T-03	40	20.20	17.85	17.65	15.60	13.00	14.00
20877-050T-03	50	24.20	21.85	21.65	19.60	17.00	18.00
20877-060T-03	60	28.20	25.85	25.65	23.60	21.00	22.00

With PULL TAPE HOLDER

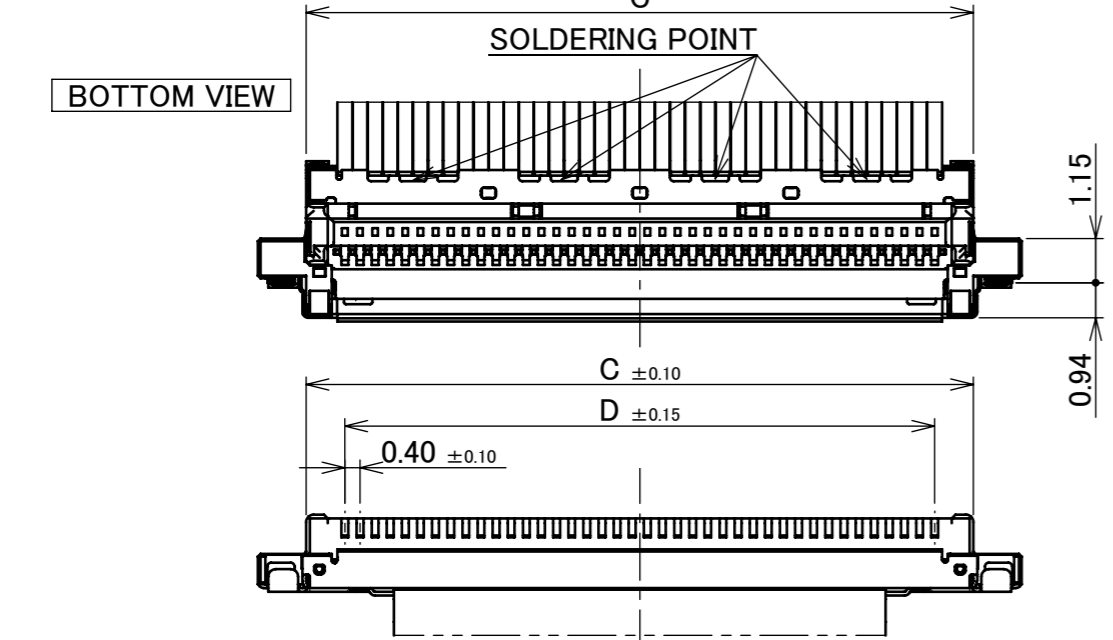
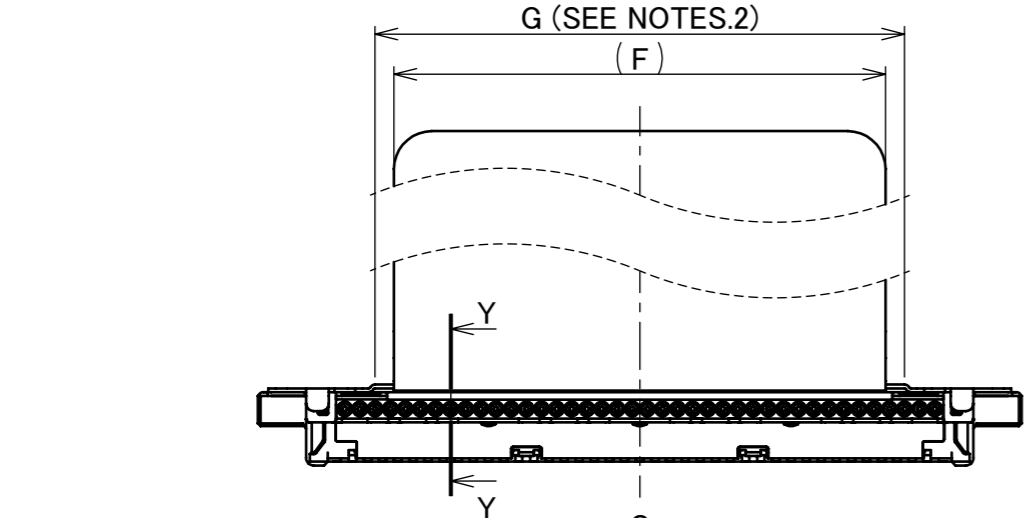
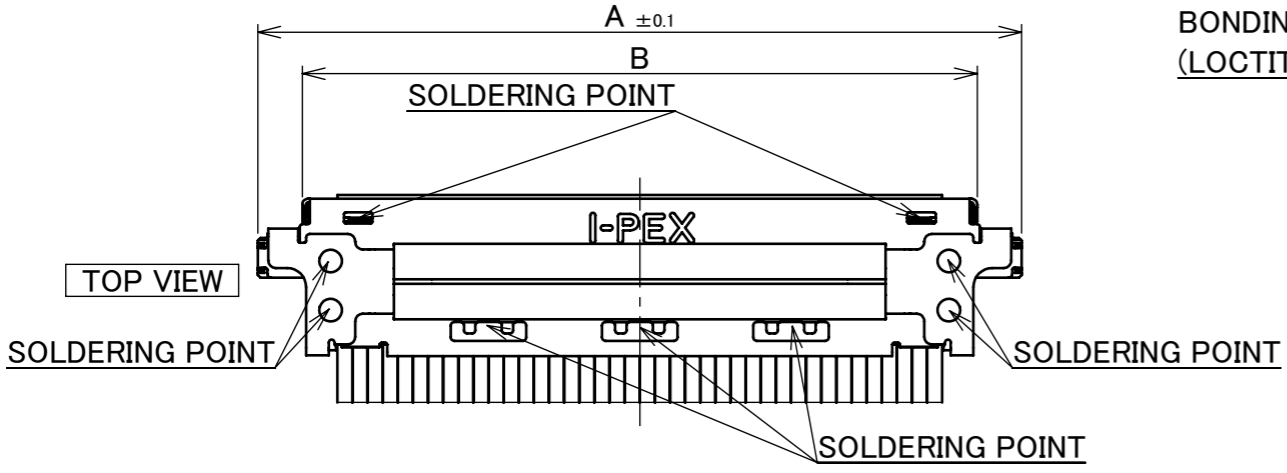

BONDING
(LOCTITE 352 RECOMMENDS)

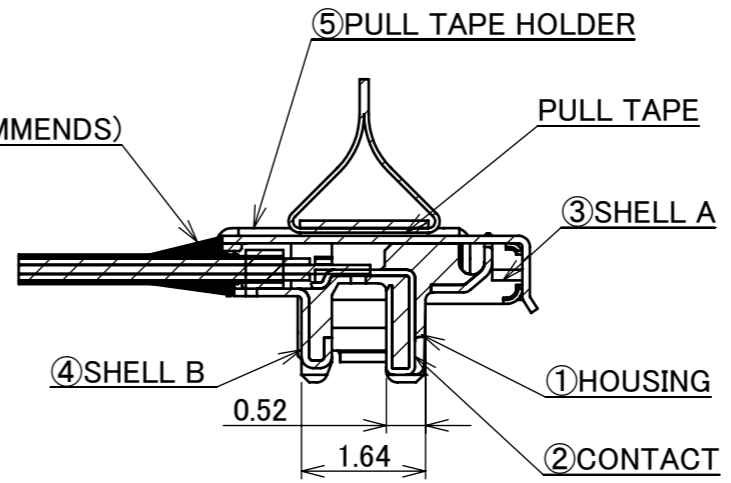

SECT. Y-Y
(S=10/1)

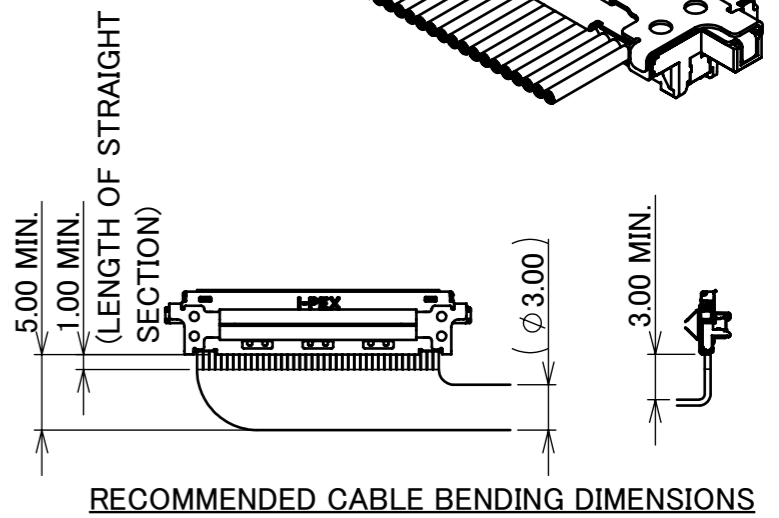
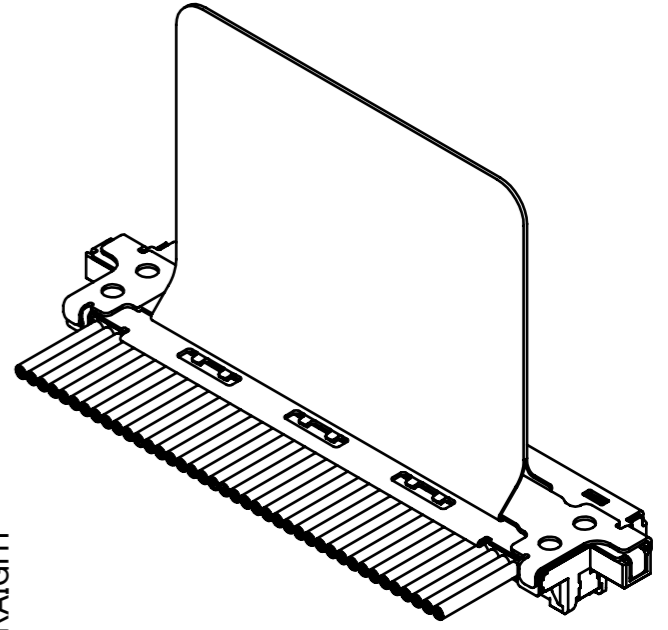
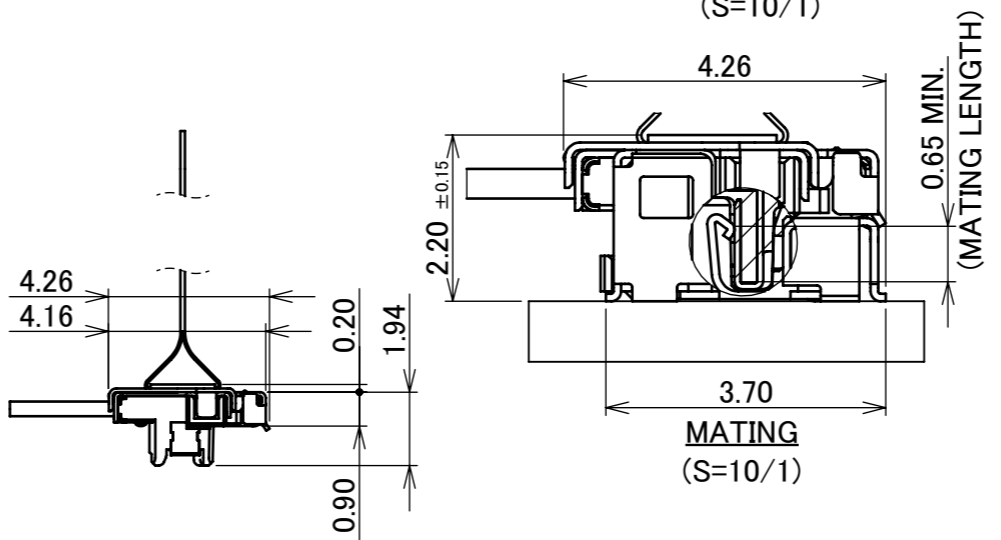

PATENT PENDING

NO.	DISCRIPTION	MATERIAL	FINISH , REMARKS
5	PULL TAPE HOLDER	PHOSPHOR BRONZE	PARTIAL Au 0.003 μ m MIN. OVER Ni 1.0 μ m MIN.
4	SHELL B	PHOSPHOR BRONZE	PARTIAL Au 0.003 μ m MIN. OVER Ni 1.0 μ m MIN.
3	SHELL A	PHOSPHOR BRONZE	PARTIAL Au 0.003 μ m MIN. OVER Ni 1.0 μ m MIN.
2	CONTACT	CORSON ALLOY	ALL OVER Ni 1.0 μ m MIN. CONTACT & SOLDERING AREA : Au 0.03 μ m MIN.
1	HOUSING	LCP	UL94V-0 ,BLACK

NOTES.
1.RECOMMENDED PULL-TAPE
PULL-TAPE : TERAOKA's INSULATION TAPE No.650S(#50) t=0.08
2.PULL-TAPE CAN BE PUT WITHIN THE RANGE OF "G" STRIAIGHT AREA.

ANGLE	±2°	6 OVER 30 MAX.	±0.3	PROJECTION ⊕	SERIES No. R3R2R2R0	CUSTOMER COPY					
	6 MAX.	±0.2	30 OVER 120 MAX.						±0.5		
GENERAL TOLERANCE.				TITLE CABLINE®-UM PLUG CABLE ASSEMBLY		SCALE 5:1	I-PEX				
DWG.	DATE			DWG. No.		UNIT mm					
CHK.				20877		SIZE A3				SHEET 3/5	REV. 12
APP.											

ITEMS	SPECIFICATION
APPLICABLE CABLE	MICRO-COAXIAL CABLE : AWG# 44 , 42 , 40 , 38 , 36 DISCRETE WIRE : AWG# 36 , 34 TWINAX CABLE : AWG# 40 , 42
RATING VOLTAGE	100V AC (PER CONTACT PIN)
RATING AMPERAGE (FOR CONTACT)	0.15A AC/DC [AWG#44] PER CONTACT PIN/UP TO 60 CONTACTS 0.24A AC/DC [AWG#42] PER CONTACT PIN/UP TO 49 CONTACTS 0.3A AC/DC [AWG#40] PER CONTACT PIN/UP TO 38 CONTACTS 0.5A AC/DC [AWG#38] PER CONTACT PIN/UP TO 19 CONTACTS 0.8A AC/DC [AWG#36] PER CONTACT PIN/UP TO 12 CONTACTS 1.0A AC/DC [AWG#34] PER CONTACT PIN/UP TO 10 CONTACTS ※TESTING BY A REAL MACHINE IS RECOMMENDED BECAUSE TEMPERATURE RISE MAY AFFECTED BY ACTUAL SITUATION.
OPERATING TEMPERATURE	233~378K(-40°C~+105°C)
OPERATING HUMIDITY	85% MAX.(NON-CONDENSING)
CONTACT RESISTANCE	INITIAL : 180mohm MAX.(AWG#34) / AFTER TEST : \triangle 40mohm MAX. 275mohm MAX.(AWG#36) 360mohm MAX.(AWG#38) 600mohm MAX.(AWG#40) 700mohm MAX.(AWG#42) 1080mohm MAX.(AWG#44)
GROUND SHELL RESISTANCE	INITIAL : 50mohm MAX. / AFTER TEST : \triangle 40mohm MAX.
INSULATION RESISTANCE	INITIAL : 1000Mohm MIN. / AFTER TEST : 500Mohm MIN.
DIELECTRIC WITHSTANDING VOLTAGE	AC250V 1min
DURABILITY	30 CYCLES
MATING FORCE (INITIAL / AFTER TEST)	30P : 34.00N MAX. 50P : 46.00N MAX. 40P : 40.00N MAX. 60P : 52.00N MAX.
UNMATING FORCE (INITIAL / AFTER TEST)	30P : 3.0N MIN. 50P : 5.0N MIN. 40P : 4.0N MIN. 60P : 6.0N MIN.
CABLE RETENTION FORCE	30P : 14.70N MIN. 50P : 24.50N MIN. 40P : 19.60N MIN. 60P : 29.40N MIN.
PRODUCT SPECIFICATION	PRS-2514
TEST REPORT	TR-18067 (RECEPTACLE:20879-0**E-01) TR-18088 (RECEPTACLE:20879-0**E-02)
INSTRUCTION MANUAL	HIM-18033
ASSEMBLY MANUAL	ASM-18003
APPEARANCE CRITERIA No.	QLS-A***

ANGLE	$\pm 2^\circ$	6 OVER 30 MAX.	± 0.3	PROJECTION 	SERIES No. R3R2R2R0	CUSTOMER COPY			
6 MAX.	± 0.2	30 OVER 120 MAX.	± 0.5			TITLE CABLIN [®] -UM PLUG CABLE ASSEMBLY	SCALE -	I-PEX	
GENERAL TOLERANCE.				DWG. No.	20877	UNIT mm	SIZE A3		
DWG.	DATE			CHK.	APP.				

PART NO.	Pos.	D
20877-030T-0#	30	11.60
20877-040T-0#	40	15.60
20877-050T-0#	50	19.60
20877-060T-0#	60	23.60

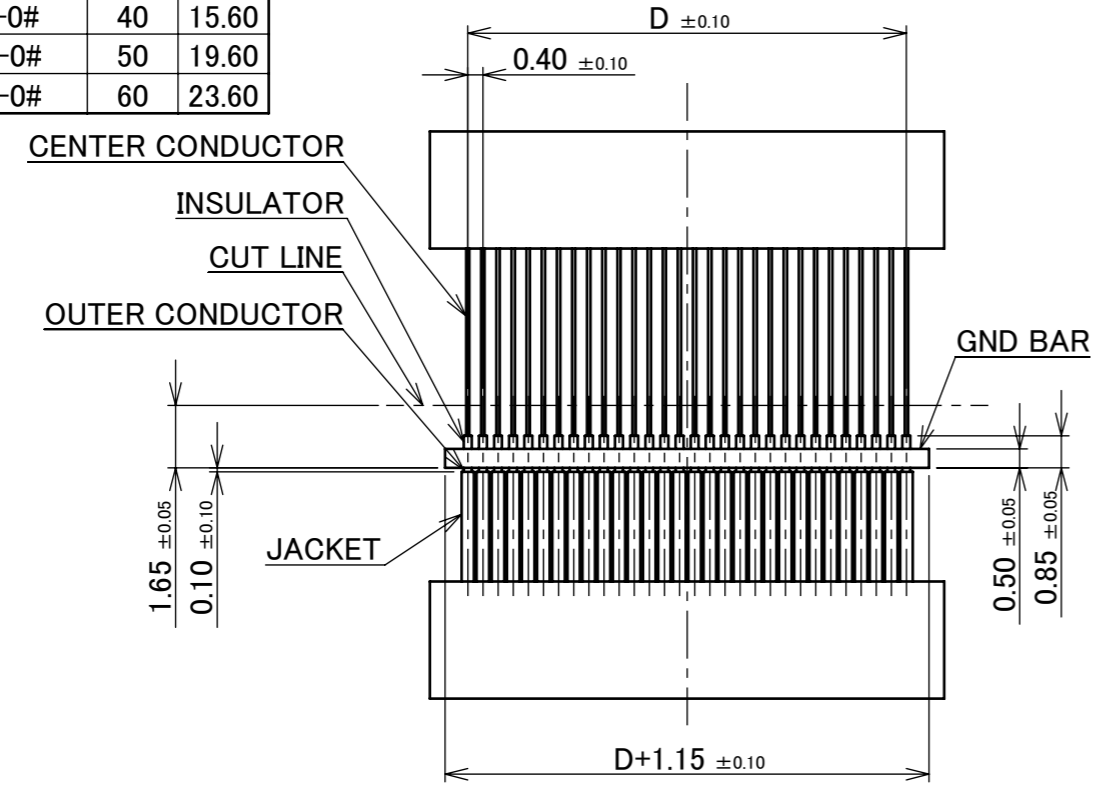

RECOMMENDED MICRO-COAXIAL CABLE DIM.

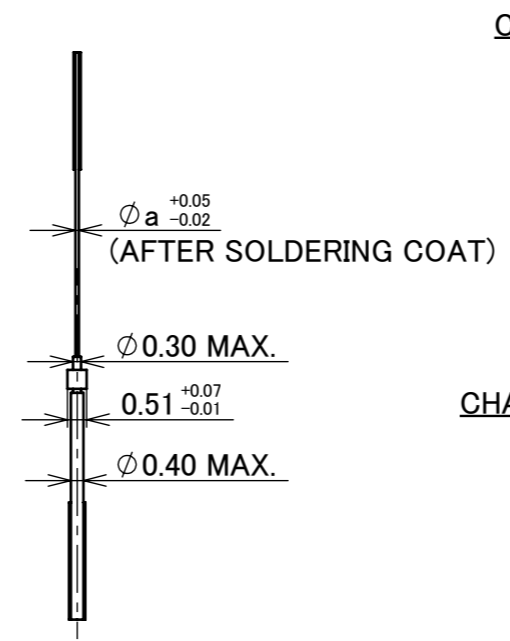

MICRO-COAXIAL CABLE AWG#**

CHARACTERISTIC IMPEDANCE MATCHING MICRO-COAXIAL CABLE

	a
#38	0.12
#40	0.09
#42	0.075
#44	0.063

CHARACTERISTIC IMPEDANCE UN-MATCHING MICRO-COAXIAL CABLE

	a
#36	0.15

MICRO-COAXIAL CABLE #36 : NOT RECOMMENDED FOR HIGH SPEED SIGNAL TRANSFER

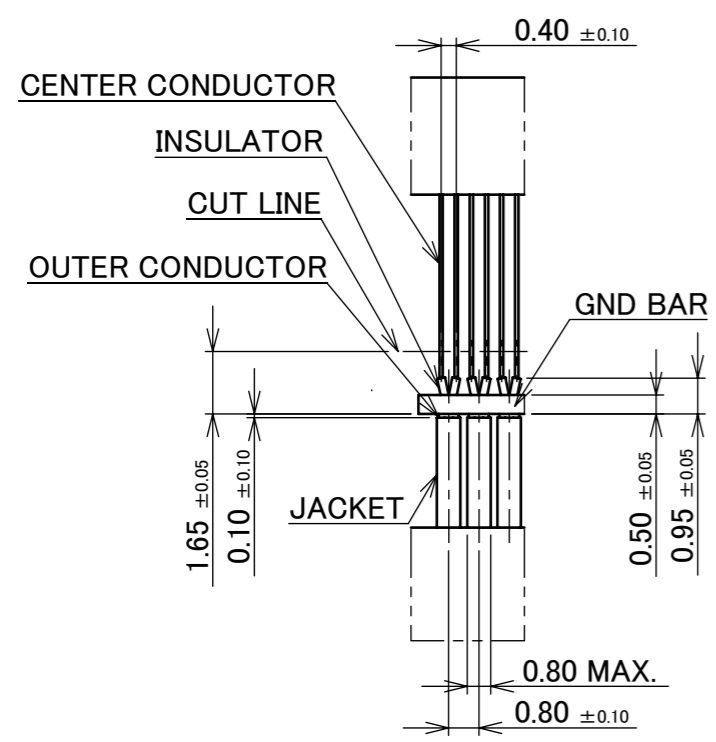

RECOMMENDED TWINAX CABLE DIM.

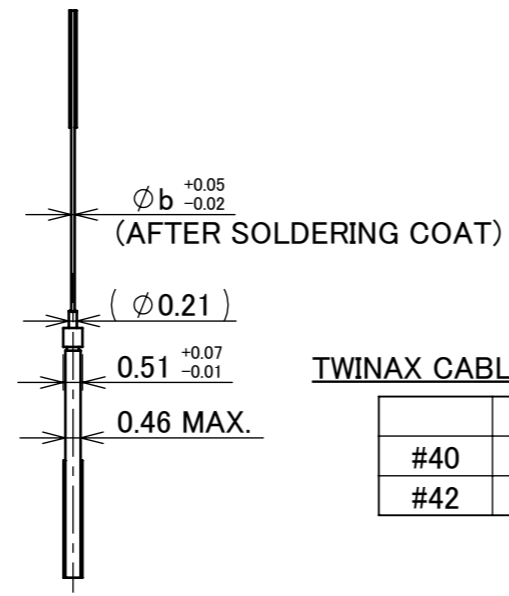

TWINAX CABLE AWG#**

TWINAX CABLE DIMENSION

	b
#40	0.09
#42	0.075

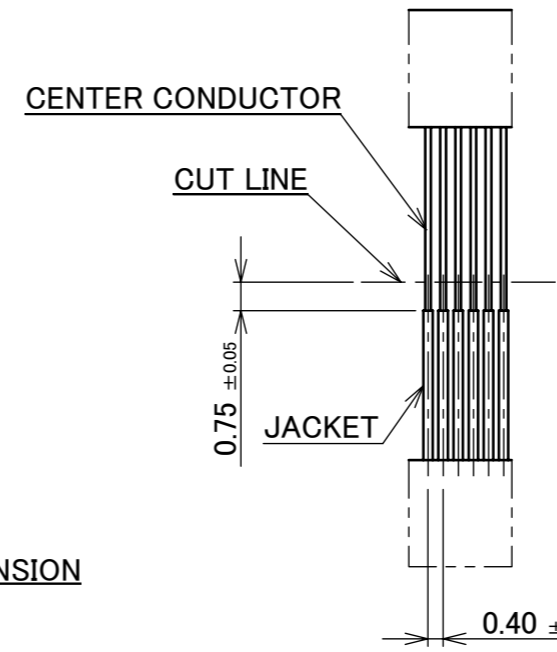

RECOMMENDED DISCRETE WIRE DIM.

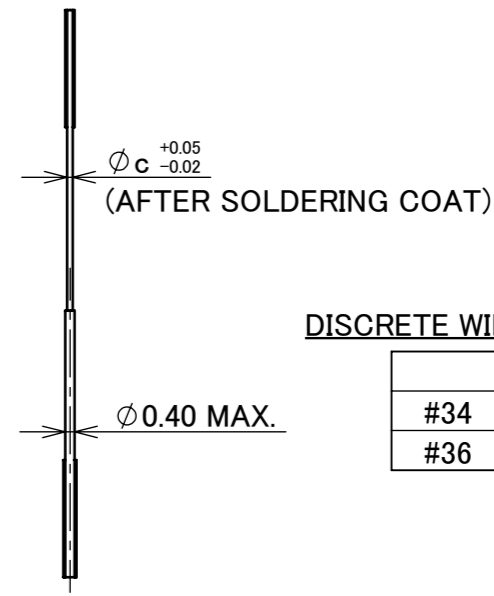

DISCRETE WIRE AWG#**

DISCRETE WIRE DIMENSION

	c
#34	0.192
#36	0.15

ANGLE	±2°	6 OVER 30 MAX.	±0.3	PROJECTION ⊕	SERIES No. R3R2R2R0	CUSTOMER COPY			
	6 MAX.	±0.2	30 OVER 120 MAX.						±0.5
GENERAL TOLERANCE.					TITLE CABLINE®-UM PLUG CABLE ASSEMBLY	SCALE	I-PEX		
DWG.	DATE					5:1			
CHK.						UNIT			
APP.						mm			
					DWG. No.	20877	SIZE	SHEET	REV.
							A3	5/5	12