

Recommended P/N 20877-0**T-01

PART NO.	Pos.	A	B	C	D	F	G
20877-030T-03	30	16.20	13.85	13.65	11.60	9.00	10.00
20877-040T-03	40	20.20	17.85	17.65	15.60	13.00	14.00
20877-060T-03	60	28.20	25.85	25.65	23.60	21.00	22.00

With PULL TAPE HOLDER

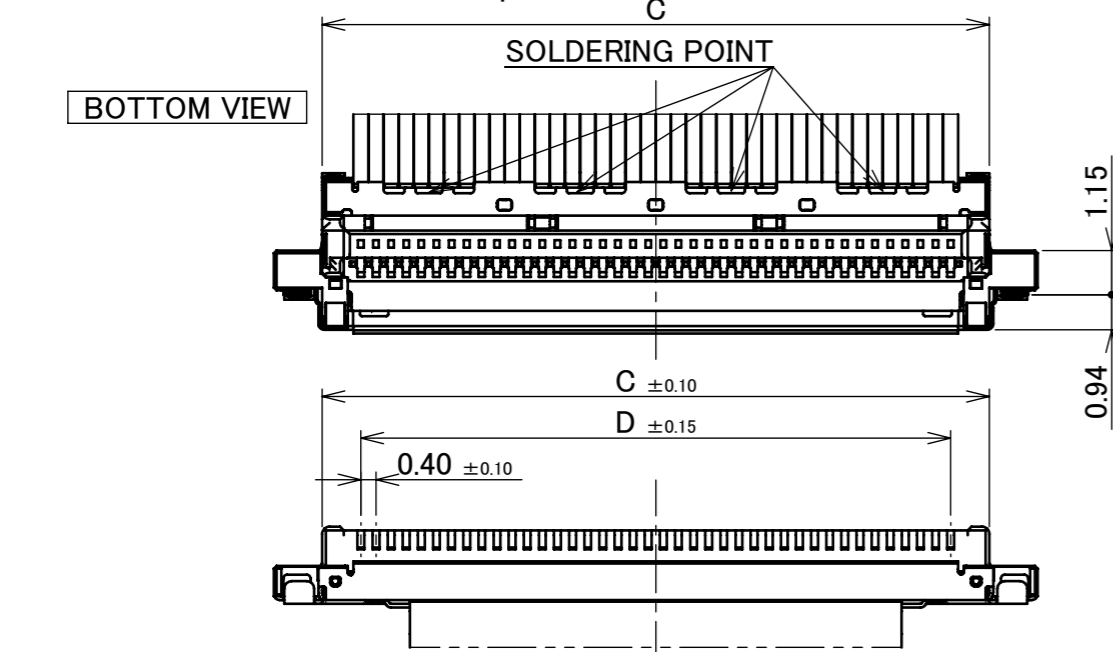
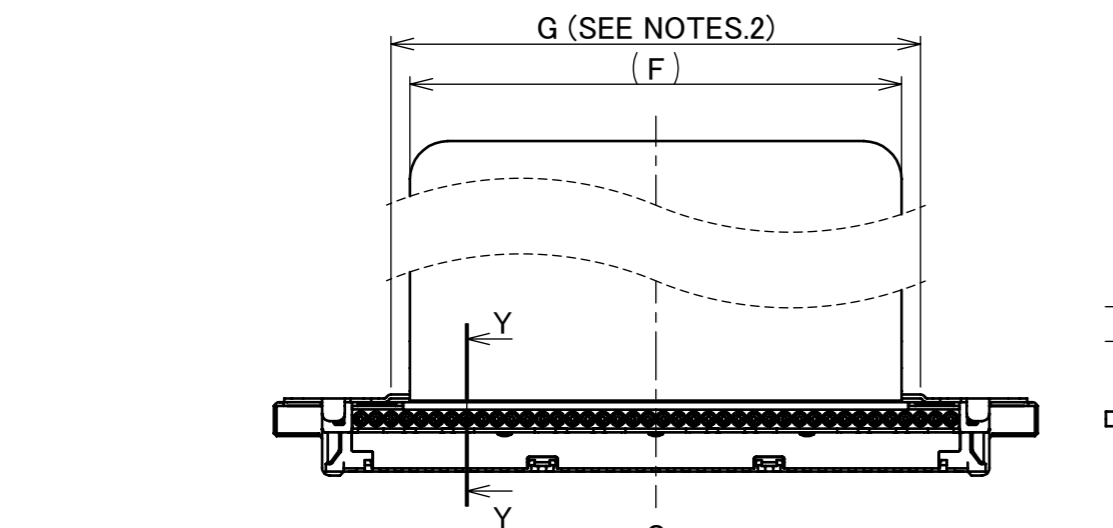
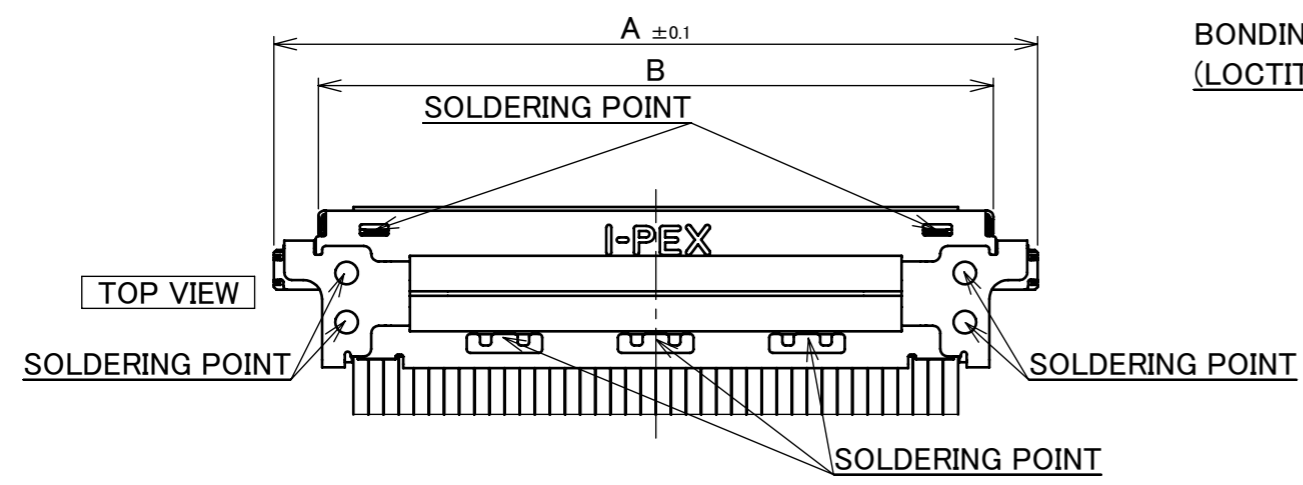

BONDING
(LOCTITE 352 RECOMMENDS)

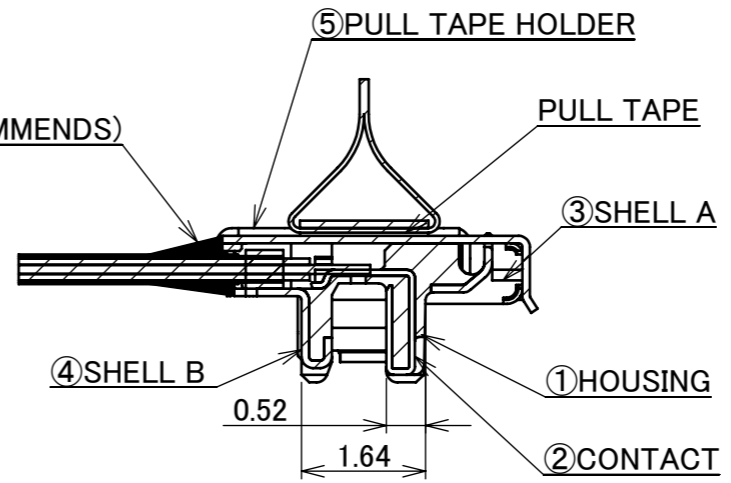

SECT. Y-Y
(S=10/1)

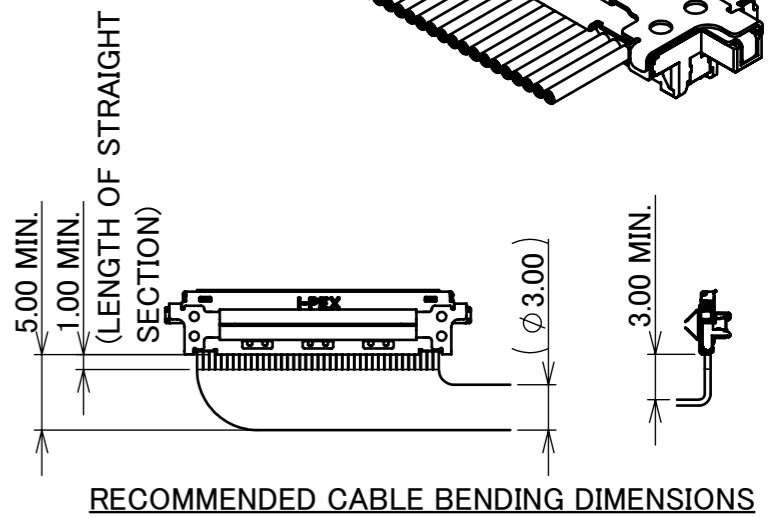
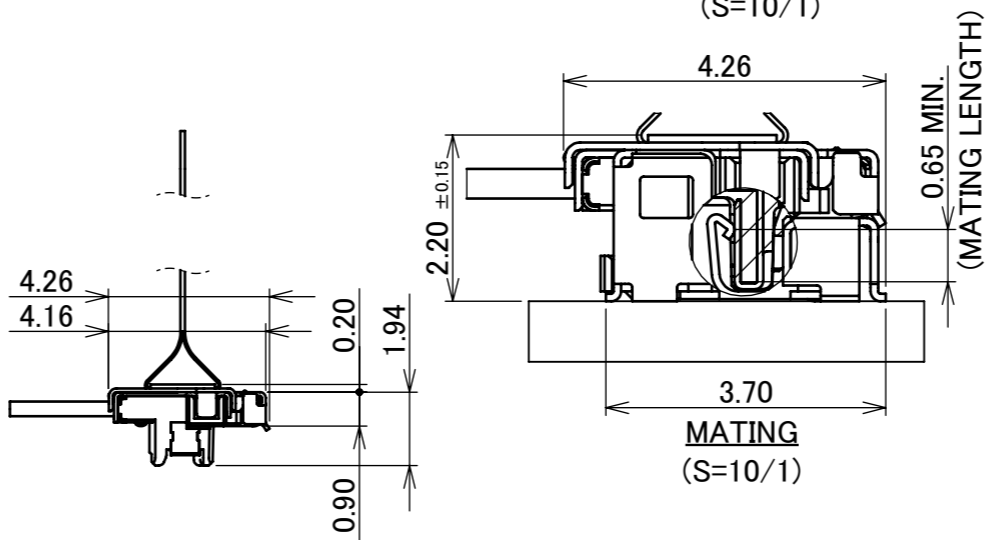

PATENT PENDING

NO.	DISCRIPTION	MATERIAL	FINISH , REMARKS
5	PULL TAPE HOLDER	PHOSPHOR BRONZE	PARTIAL Au 0.003 μ m MIN. OVER Ni 1.0 μ m MIN.
4	SHELL B	PHOSPHOR BRONZE	PARTIAL Au 0.003 μ m MIN. OVER Ni 1.0 μ m MIN.
3	SHELL A	PHOSPHOR BRONZE	PARTIAL Au 0.003 μ m MIN. OVER Ni 1.0 μ m MIN.
2	CONTACT	CORSON ALLOY	ALL OVER Ni 1.0 μ m MIN. CONTACT & SOLDERING AREA : Au 0.03 μ m MIN.
1	HOUSING	LCP	UL94V-0 ,BLACK

NOTES.
1.RECOMMENDED PULL-TAPE
PULL-TAPE : TERAOKA's INSULATION TAPE No.650S(#50) t=0.08
2.PULL-TAPE CAN BE PUT WITHIN THE RANGE OF "G" STRIAIGHT AREA.

ANGLE	±2°	6 OVER 30 MAX.	±0.3	PROJECTION ⊕	SERIES No. R3R2R2R0	CUSTOMER COPY			
	6 MAX.	±0.2	30 OVER 120 MAX.						±0.5
GENERAL TOLERANCE.					TITLE CABLINE®-UM PLUG CABLE ASSEMBLY	SCALE	I-PEX		
DWG.	DATE			5:1					
CHK.				UNIT		mm			
APP.				SIZE		SHEET			
					DWG. No.	20877	A3	3/5	10

ITEMS	SPECIFICATION
APPLICABLE CABLE	MICRO COAX : AWG# 44 , 42 , 40 , 38 , 36 DISCRETE : AWG# 36 , 34 TWINCOAX : AWG# 40 , 42
RATING VOLTAGE	100V AC (PER CONTACT PIN)
RATING AMPERAGE (FOR CONTACT)	0.15A AC/DC [AWG#44] PER CONTACT PIN/UP TO 60 CONTACTS 0.24A AC/DC [AWG#42] PER CONTACT PIN/UP TO 49 CONTACTS 0.3A AC/DC [AWG#40] PER CONTACT PIN/UP TO 38 CONTACTS 0.5A AC/DC [AWG#38] PER CONTACT PIN/UP TO 19 CONTACTS 0.8A AC/DC [AWG#36] PER CONTACT PIN/UP TO 12 CONTACTS 1.0A AC/DC [AWG#34] PER CONTACT PIN/UP TO 10 CONTACTS ※TESTING BY A REAL MACHINE IS RECOMMENDED BECAUSE TEMPERATURE RISE MAY AFFECTED BY ACTUAL SITUATION.
OPERATING TEMPERATURE	233~378K(-40°C~+105°C)
OPERATING HUMIDITY	85% MAX.(NON-CONDENSING)
CONTACT RESISTANCE	INITIAL : 180mohm MAX.(AWG#34) / AFTER TEST : \triangle 40mohm MAX. 275mohm MAX.(AWG#36) 360mohm MAX.(AWG#38) 600mohm MAX.(AWG#40) 700mohm MAX.(AWG#42) 1080mohm MAX.(AWG#44)
GROUND SHELL RESISTANCE	INITIAL : 50mohm MAX. / AFTER TEST : \triangle 40mohm MAX.
INSULATION RESISTANCE	INITIAL : 1000Mohm MIN. / AFTER TEST : 500Mohm MIN.
DIELECTRIC WITHSTANDING VOLTAGE	AC250V 1min
DURABILITY	30 CYCLES
MATING FORCE (INITIAL / AFTER TEST)	30P : 34.00N MAX. 60P : 52.00N MAX. 40P : 40.00N MAX.
UNMATING FORCE (INITIAL / AFTER TEST)	30P : 3.0N MIN. 60P : 6.0N MIN. 40P : 4.0N MIN.
CABLE RETENTION FORCE	30P : 14.70N MIN. 60P : 29.40N MIN. 40P : 19.60N MIN.
PRODUCT SPECIFICATION	PRS-2514
TEST REPORT	TR-18067 (RECEPTACLE:20879-0**E-01) TR-18088 (RECEPTACLE:20879-0**E-02)
INSTRUCTION MANUAL	HIM-18033
ASSEMBLY MANUAL	ASM-18003
APPEARANCE CRITERIA No.	QLS-A***

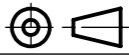
ANGLE	$\pm 2^\circ$	6 OVER 30 MAX.	± 0.3	PROJECTION 	SERIES No. R3R2R2R0	CUSTOMER COPY		
6 MAX.	± 0.2	30 OVER 120 MAX.	± 0.5					
GENERAL TOLERANCE.				TITLE CABLIN [®] -UM PLUG CABLE ASSEMBLY	SCALE	I-PEX		
DWG.	DATE				-			
CHK.					UNIT			
APP.					mm			
				DWG. No.	20877	SIZE	SHEET	REV.
						A3	4/5	10

PART NO.	Pos.	D
20877-030T-0#	30	11.60
20877-040T-0#	40	15.60
20877-060T-0#	60	23.60

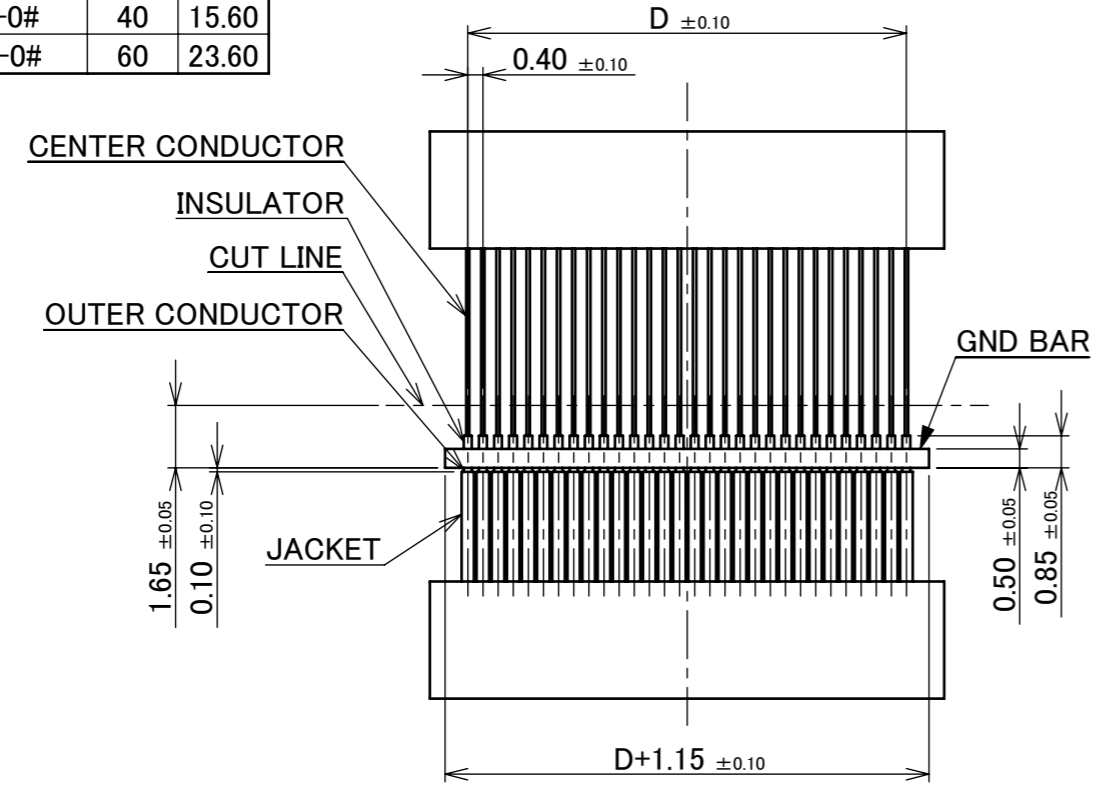

RECOMMENDED MICRO COAX CABLE DIM.

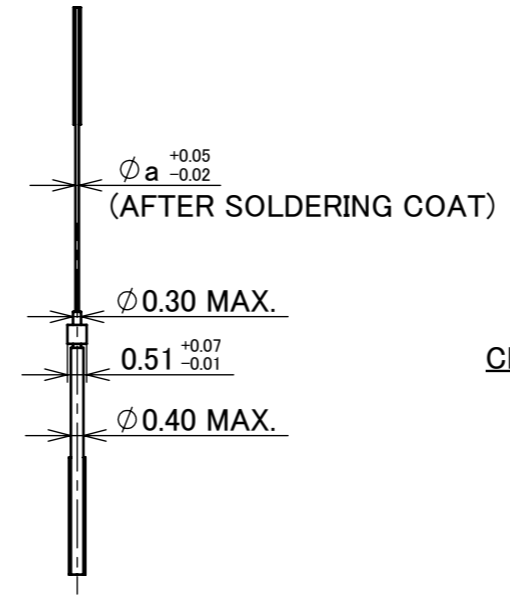

MICRO COAX CABLE AWG#**

CHARACTERISTIC IMPEDANCE MATCHING MICRO COAX CABLE

	a
#38	0.12
#40	0.09
#42	0.075
#44	0.063

CHARACTERISTIC IMPEDANCE UN-MATCHING MICRO COAX CABLE

	a
#36	0.15

MICRO COAX CABLE #36 : NOT RECOMMENDED FOR HIGH SPEED SIGNAL TRANSFER

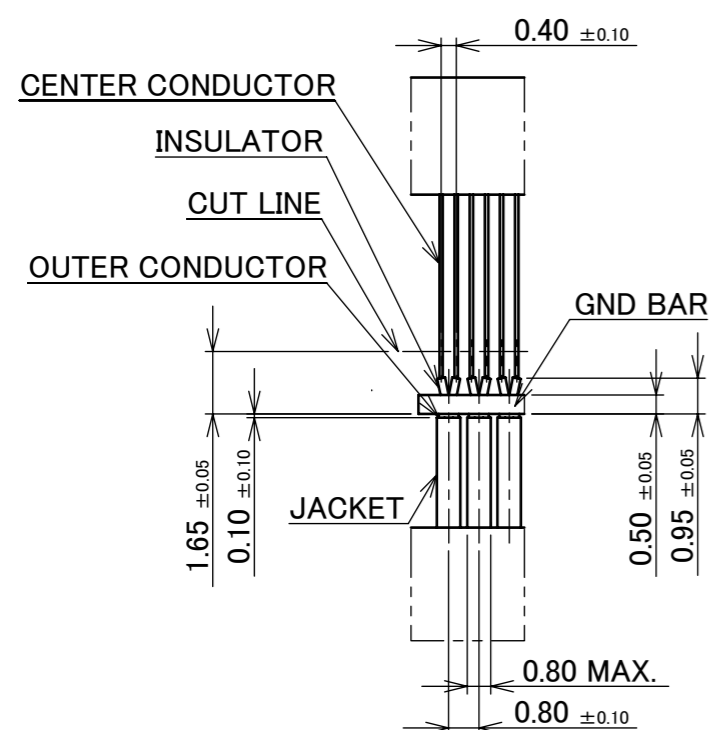

RECOMMENDED TWINCOAX CABLE DIM.

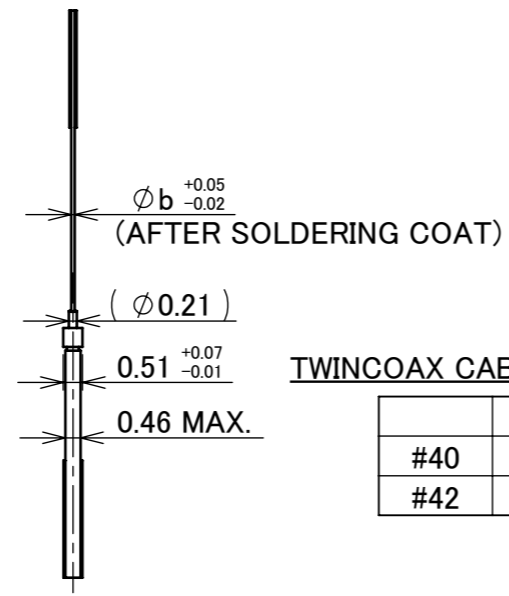

TWINCOAX CABLE DIMENSION

	b
#40	0.09
#42	0.075

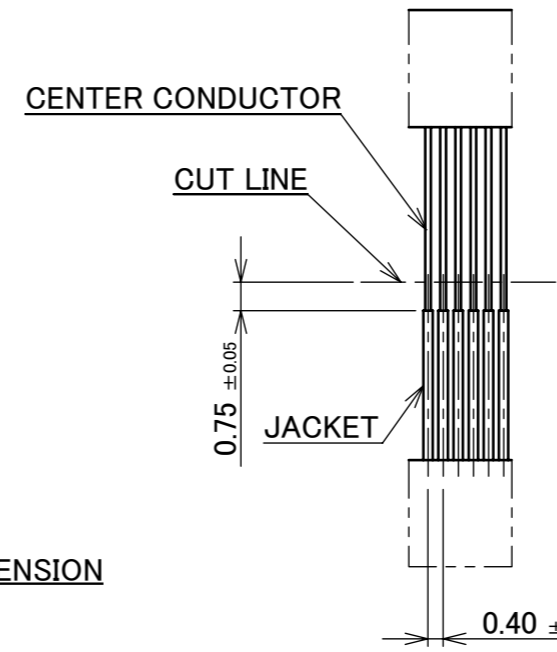

RECOMMENDED DISCRETE CABLE DIM.

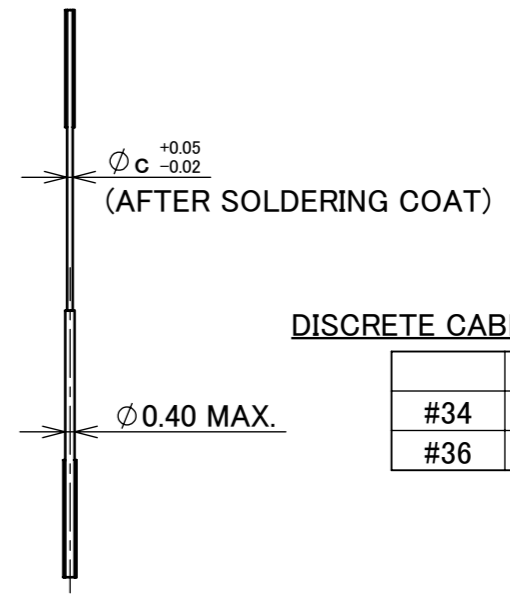

DISCRETE CABLE AWG#**

DISCRETE CABLE DIMENSION

	c
#34	0.192
#36	0.15

ANGLE	±2°	6 OVER 30 MAX.	±0.3	PROJECTION ⊕	SERIES No. R3R2R2R0	CUSTOMER COPY			
	6 MAX.	±0.2	30 OVER 120 MAX.						±0.5
GENERAL TOLERANCE.				TITLE		SCALE	I-PEX		
DWG.	DATE			CABLIN [®] -UM PLUG CABLE ASSEMBLY		5:1			
CHK.						UNIT			
APP.				DWG. No. 20877		mm			
						SIZE	SHEET	REV.	
						A3	5/5	10	