

Recommended P/N 21103-0**E-02

PART NO.	Pos.	A	B	C	D	E	F	G
21103-040E-02	40	17.65	20.20	16.50	16.33	15.60	16.19	10.80
21103-070E-02	70	29.65	32.20	28.50	28.33	27.60	28.19	25.20



Halogen Free



RoHS Compliant

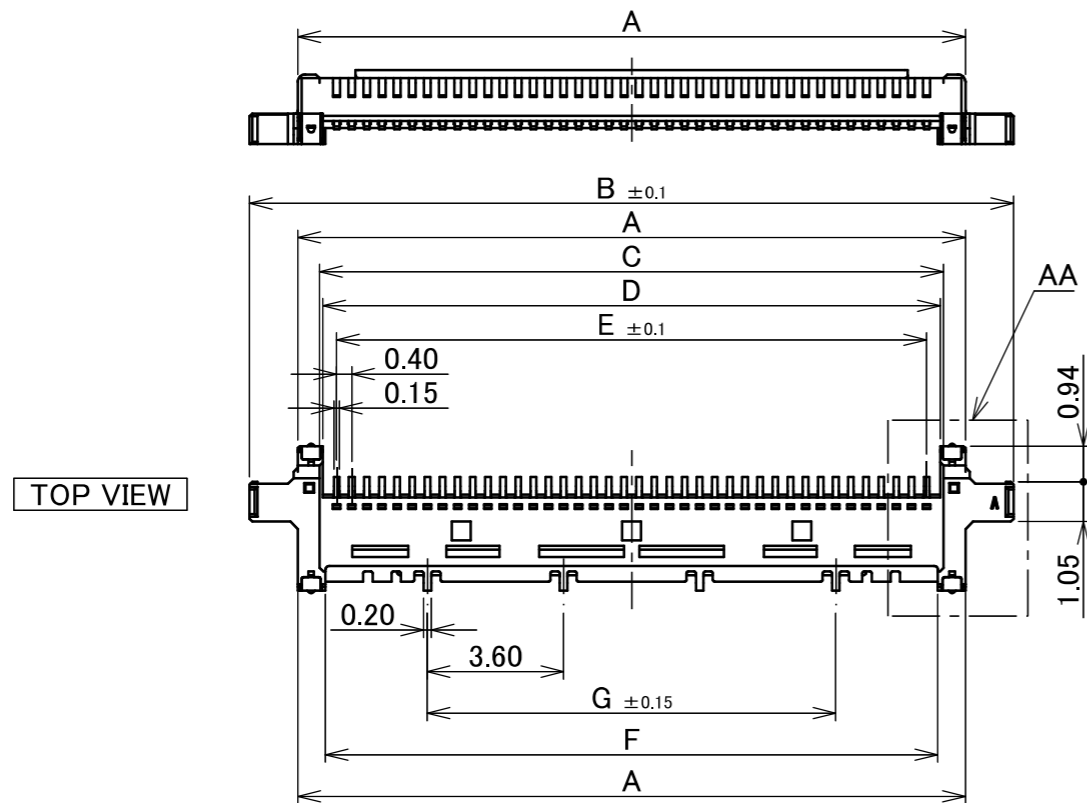
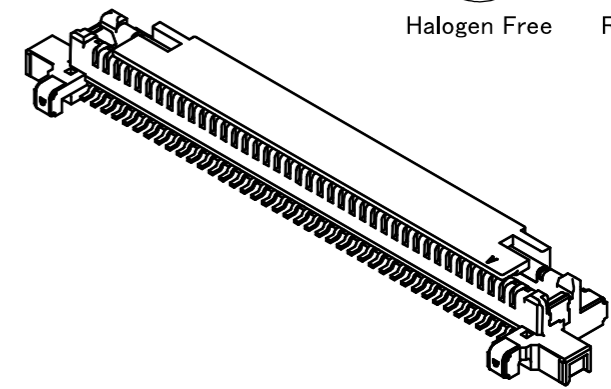

TOP VIEW

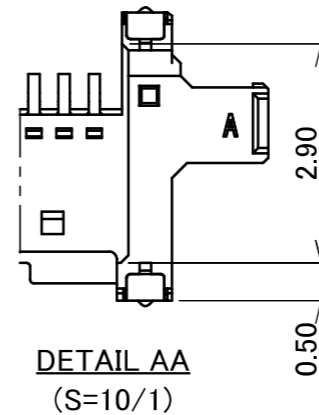

DETAIL AA
(S=10/1)

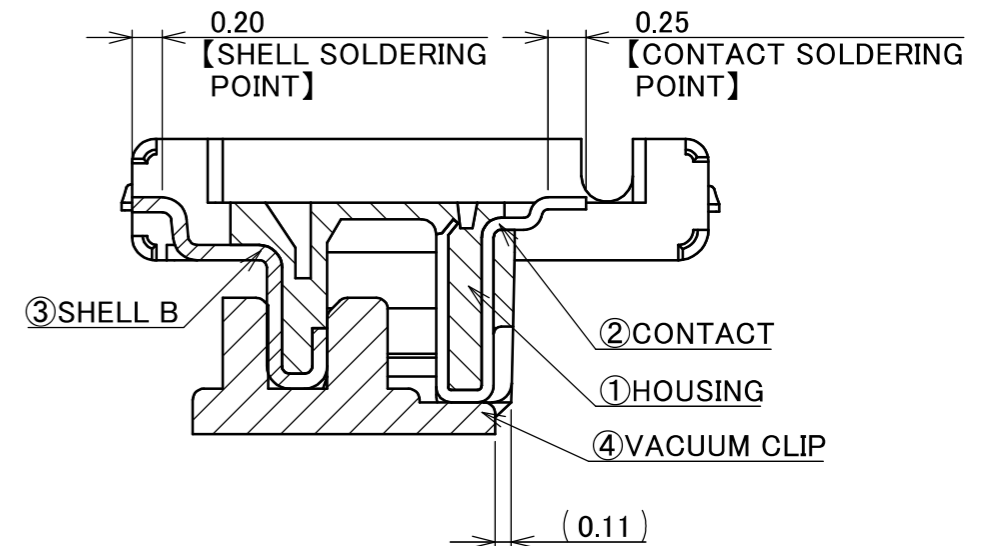

SECT. BB-BB
(S=20 : 1)

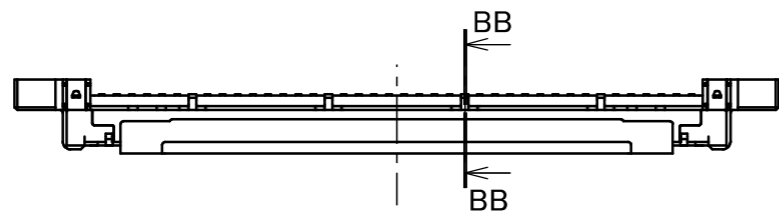

BOTTOM VIEW

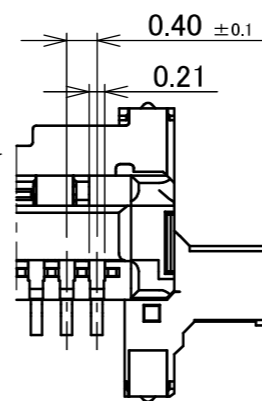
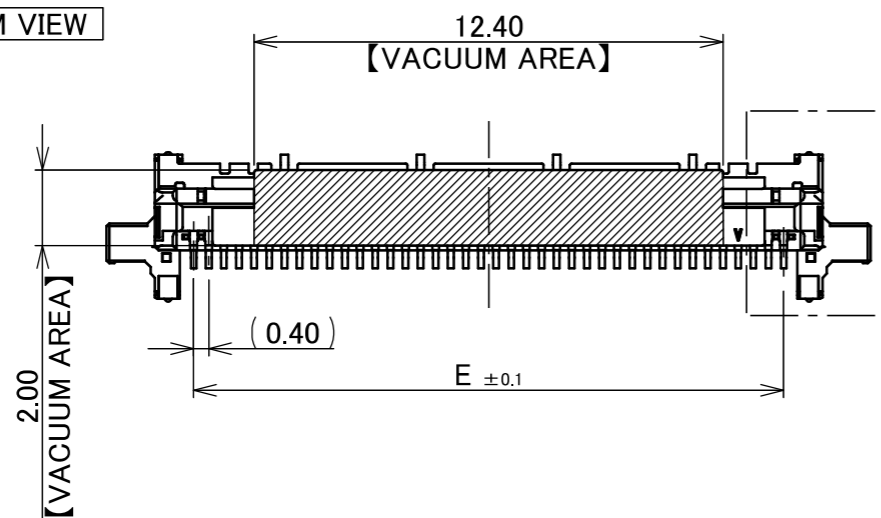
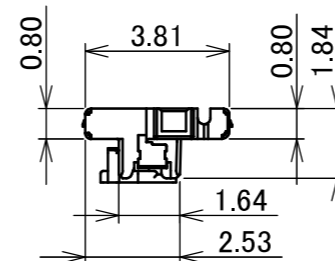

NO.	DISCRIPTION	MATERIAL	FINISH , REMARKS
4	VACUUM CLIP	LCP	-
3	SHELL B	PHOSPHOR BRONZE	ALL Au 0.01 μ m MIN. OVER Ni 1.00 μ m MIN.
2	CONTACT	CORSON ALLOY	ALL OVER Ni 1.00 μ m MIN. CONTACT & SOLDERING AREA : Au 0.03 μ m MIN.
1	HOUSING	LCP	UL94V-0 ,BLACK

REV.	ECN	BY	DATE	APP.	ANGLE	PROJECTION	SERIES No.	CUSTOMER COPY		
					±2° 6 OVER 30 MAX. ±0.3 6 MAX. ±0.2 30 OVER 120 MAX. ±0.5	⊕	R1			
REVISION RECORD					GENERAL TOLERANCE.		TITLE CABLINER [®] -UMF PLUG HOUSING ASSEMBLY	SCALE	I-PEX	
2	ZC00714	H.U	2026/06/08	H.I	DWG. DATE H.Uchida 2025/05/20	5:1				
1	ZC00077	K.Ta	2025/09/03	T.M	CHK. M.Nakamura	UNIT mm				
0	Z250794	H.U	2025/05/20	-	APP. T.Masunaga	SIZE SHEET A3 1/2				
							DWG. No.	21103	REV.	2

PATENT PENDING

PART NO.	Pos.	L	M	N	P	Q	QTY. PER EMBOSS REEL (PIECES / REEL)	QTY. PER PACKING CARTON (REELS / CARTON)	PACKING STANDARD
21103-040E-02	40	32.00	25.50	14.20	28.40	20.60	4500 / REEL	4 / CARTON = 18000	PST-25010
21103-070E-02	70	44.00	37.50	20.20	40.40	32.60	4500 / REEL	3 / CARTON = 13500	

PATENT PENDING

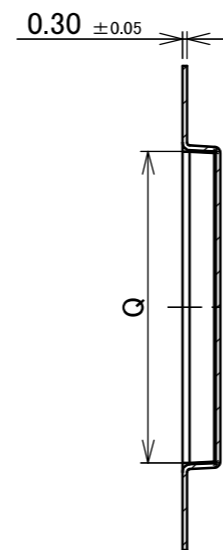
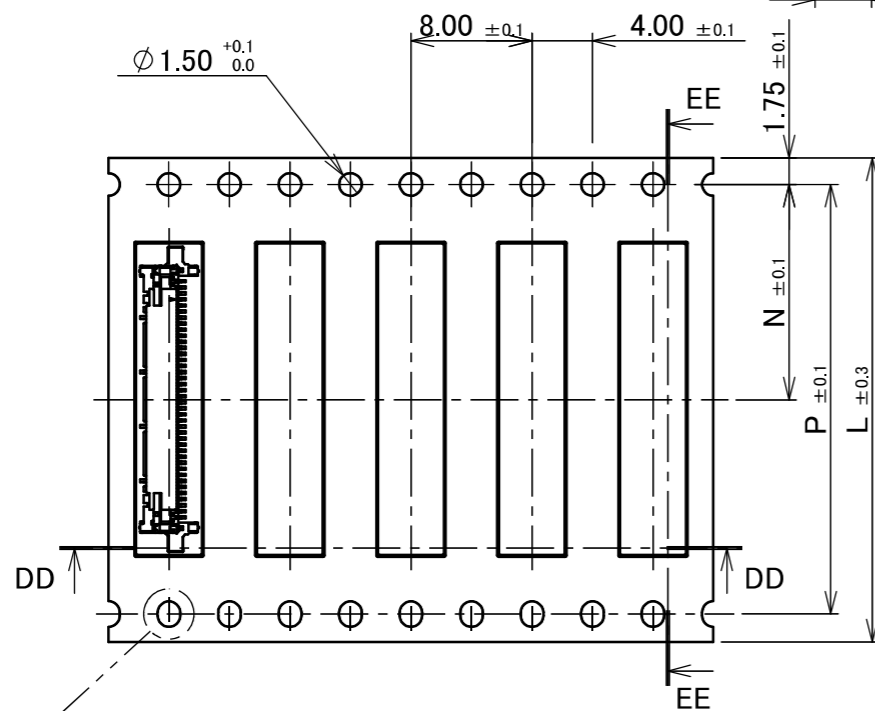
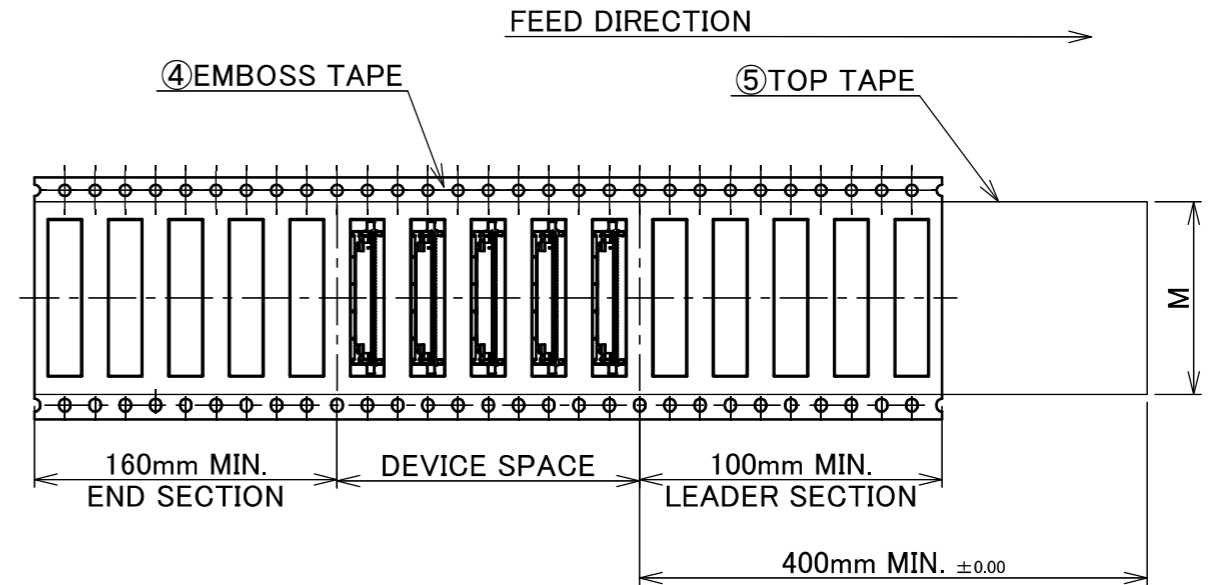
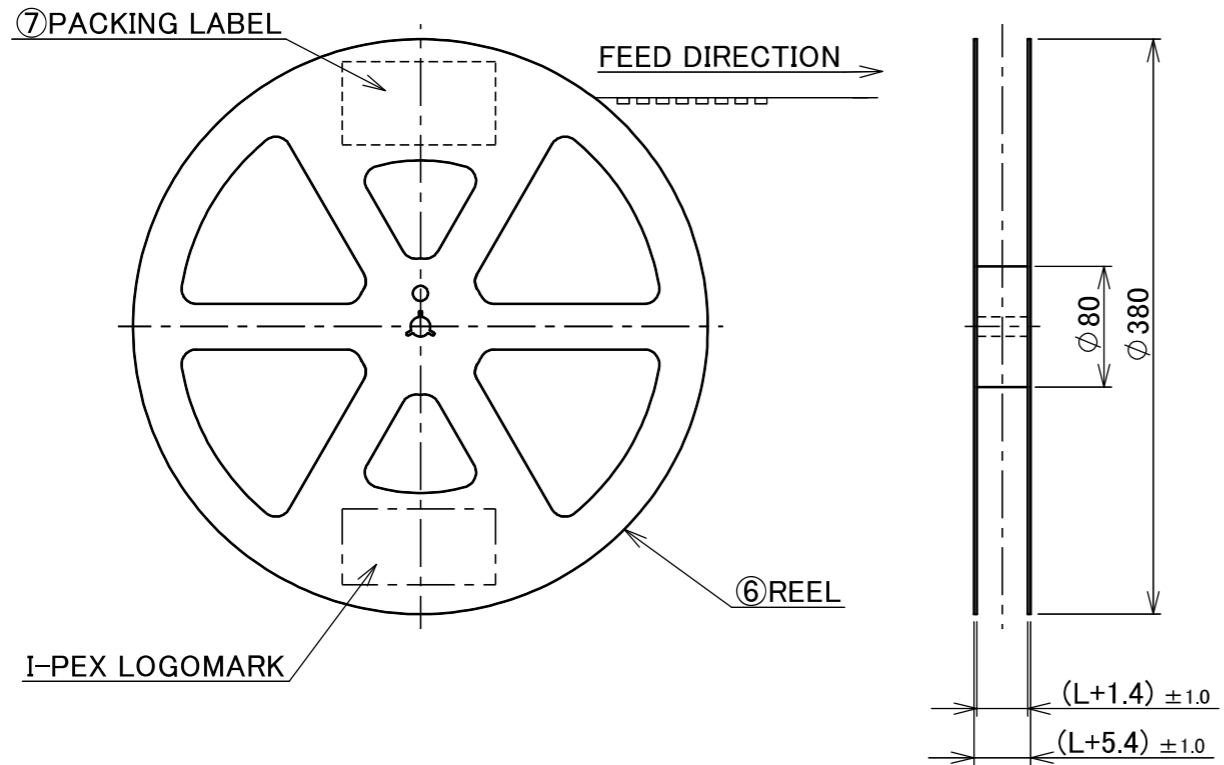

SECT EE-EE (S=2 : 1)

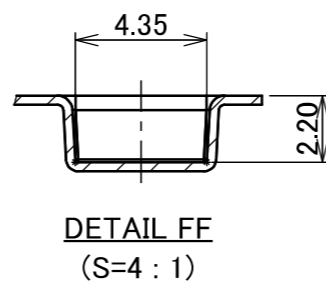
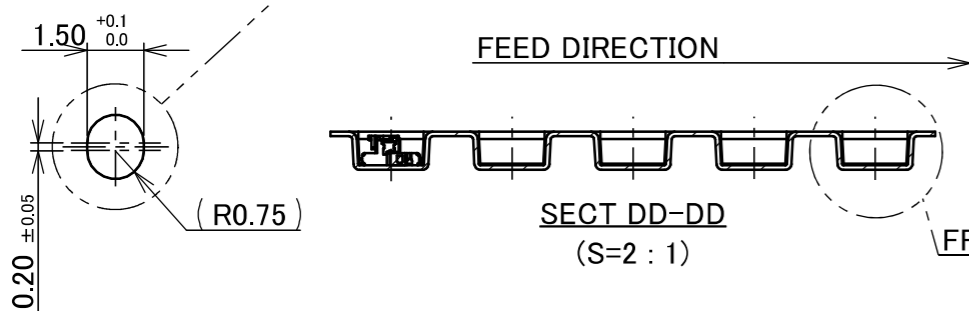

NOTES.

- TAPING SPECIFICATION FOLLOWS JIS C 0806 (IEC 60286-3).
- MAKE EMPTY SECTION OF LEADER AND END ON EACH END OF THE TAPE.
- TOP TAPE SHALL NOT STICK OUT FROM EMBOSS TAPE.
- TOP TAPE SHALL NOT COVER FEED HOLE.

NO.	DISCRIPTION	MATERIAL	FINISH , REMARKS
7	PACKING LABEL	-	-
6	REEL	PS	ANTI-STATIC TYPE BLACK
5	TOP TAPE	PET TRANSPARENCY	ANTI-STATIC TYPE
4	EMBOSS TAPE	PS TRANSPARENCY	ANTI-STATIC TYPE

ANGLE	±2°	6 OVER 30 MAX.	±0.3	PROJECTION	SERIES No.	CUSTOMER COPY
6 MAX.	±0.2	30 OVER 120 MAX.	±0.5		R1	
GENERAL TOLERANCE.				TITLE	SCALE	I-PEX
DWG.	DATE	CABLIN [®] -UMF PLUG HOUSING ASSEMBLY		5:1		
CHK.				DWG. No.	UNIT	mm
APP.				21103	A3	
				SIZE	SHEET	REV.
				A3	2/2	2