

Recommended P/N 20498-0\*\*E-41

PART No.	Pos.	A	B	C	D	E
20498-026E-##	26	12.4	10.8	8.1	3.6	6.7
20498-032E-##	32	14.2	12.6	9.9	4.5	10.9
◆ 20498-034E-##	34	14.8	13.2	10.5	4.8	11.5
20498-040E-##	40	16.6	15.0	12.3	5.7	10.9
20498-050E-##	50	19.6	18.0	15.3	7.2	11.5

◆ MARK MEANS NOT AVAILABLE

20498-0\*\*E-##  
 0 : WITHOUT VACUUM CLIP  
 1 : WITH VACUUM CLIP  
 3 : SHELL Au PLATING  
 4 : SHELL Sn PLATING  
 Pos.



Halogen Free



RoHS Compliant

PART COMBINATION TABLE	
RECEPTACLE ASSEMBLY	PLUG CABLE ASSEMBLY
20498-0**E-3#	20496-0**-30
20498-0**E-4#	20496-0**-40

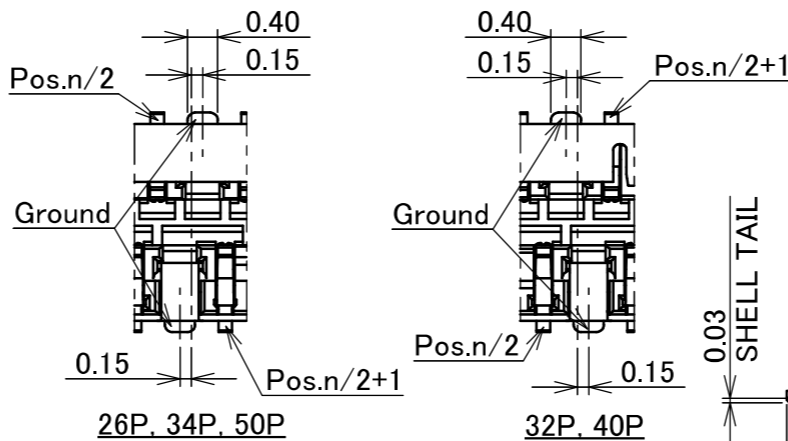
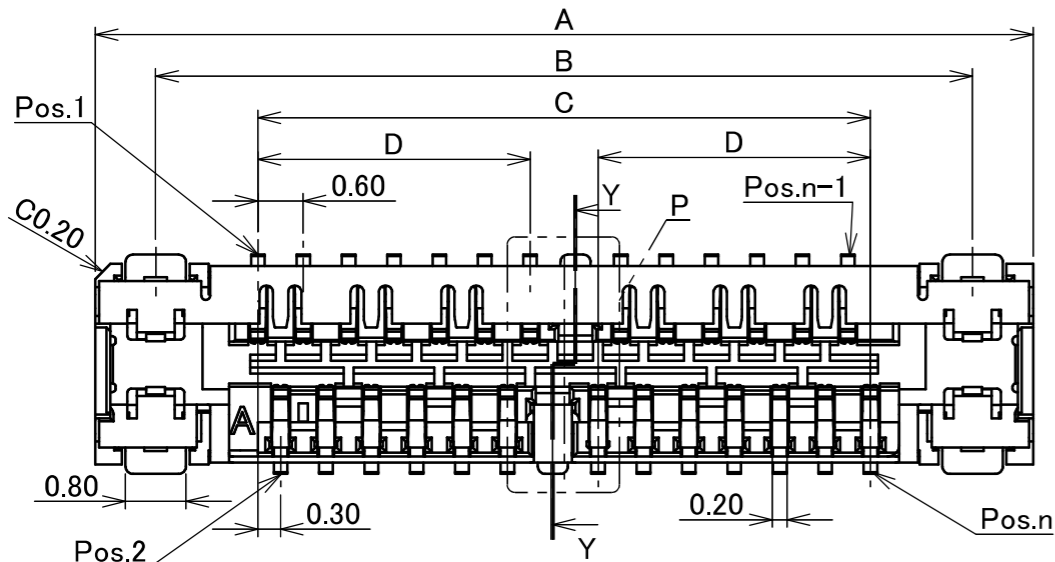
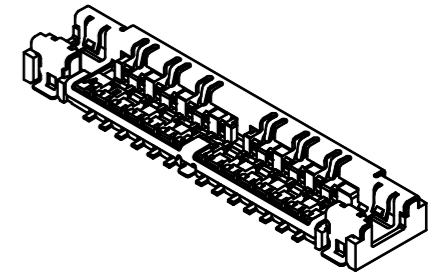

DETAIL P

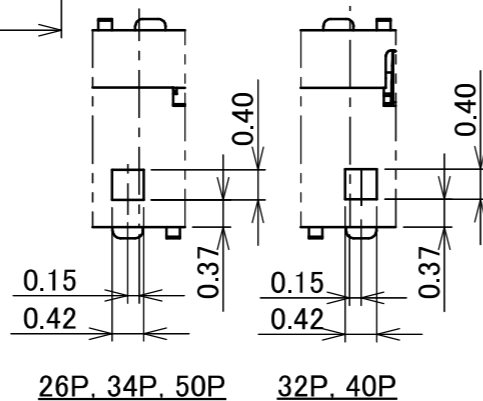
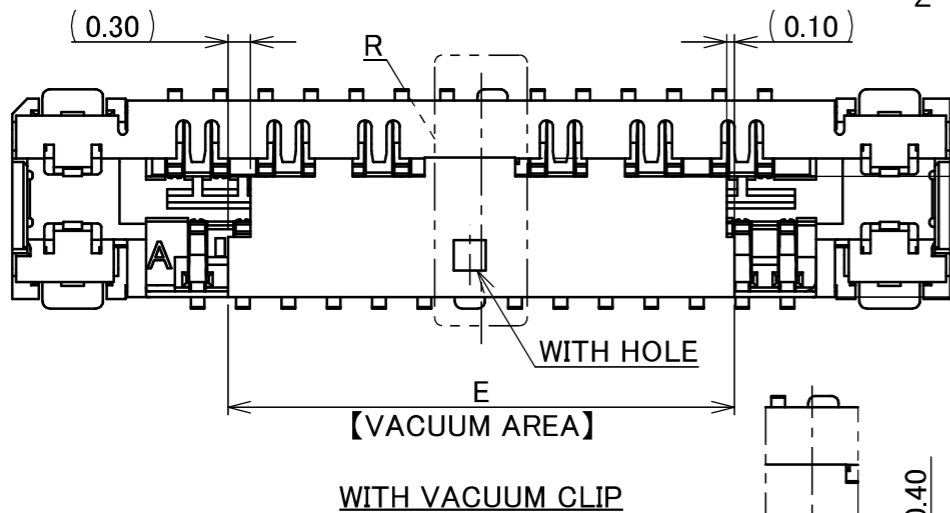
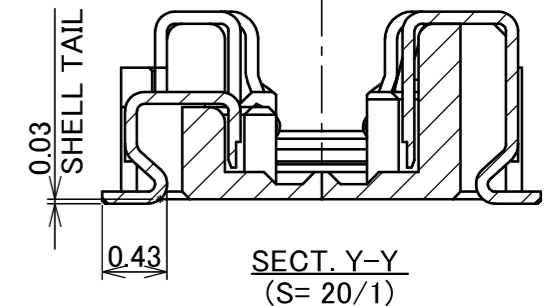
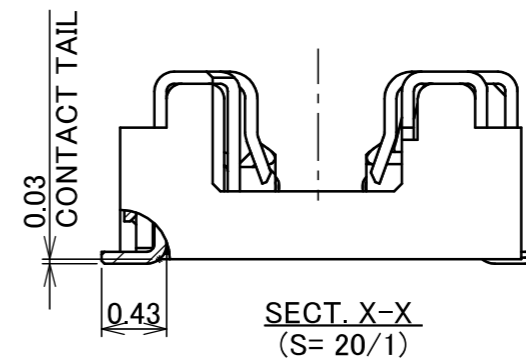
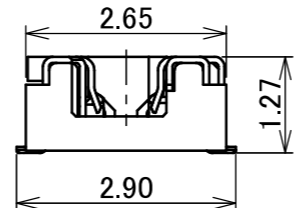
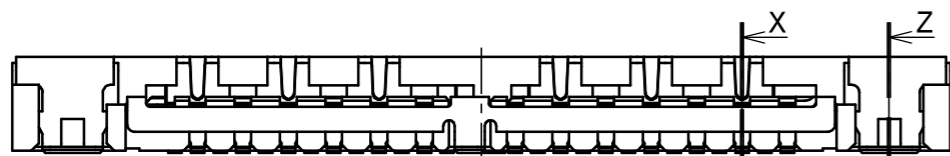
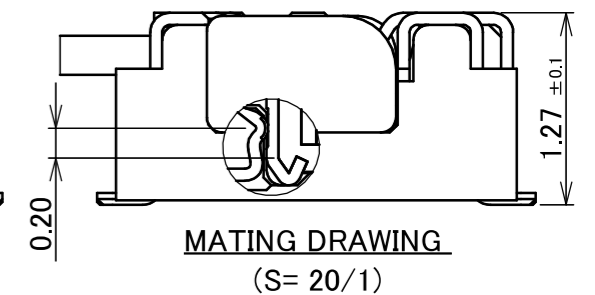
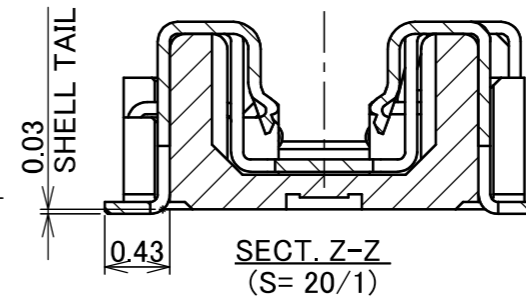

DETAIL R

NO.	DISCRIPTION	MATERIAL	FINISH , REMARKS
4	VACUUM CLIP	LCP	UL94V-0
3	SHELL	PHOSPHOR BROMZE	P/N 20498-0**E-3#: Au 0.02 μ m MIN. OVER Ni 1.00 μ m MIN. P/N 20498-0**E-4#: Sn 2.00 μ m MIN. OVER Ni 1.00 μ m MIN.
2	CONTACT	PHOSPHOR BRONZE	ALL OVER : Ni 1.00 μ m MIN. CONTACT AREA : Au 0.1 μ m MIN. SOLDERING AREA : Au 0.05 μ MIN.
1	HOUSING	LCP	UL94V-0

REV.	ECN	BY	DATE	APP.	APP.	DATE	DWG. No.	SIZE	SHEET	REV.
20	ZC00734	R.H	2026/06/03	T.M	ANGLE	±2°	6 OVER 30 MAX.	±0.3		
19	Z240030	R.H	2024/01/10	H.I	6 MAX.	±0.2	30 OVER 120 MAX.	±0.5		
18	Z220216	S.Y	2022/03/02	H.I	GENERAL TOLERANCE.					
17	Z211184	R.H	2021/09/30	H.I	DWG.	J.Ohsaka	DATE	2008/11/28		
16	Z191021	S.Y	2019/08/01	H.I	CHK.	-				
15	Z190779	S.Y	2019/06/12	H.I	APP.	E.Kawabe	DATE	2008/12/02		

ITEMS	SPECIFICATION
APPLICABLE CABLE	MICRO-COAXIAL CABLE : AWG# 46 , 44 , 42 DISCRETE WIRE : AWG# 39
RATING VOLTAGE	50V AC (PER CONTACT PIN)
RATING AMPERAGE (FOR CONTACT)	0.50A AC/DC [AWG#39] (PER CONTACT PIN / UP TO 10 CONTACTS) 0.20A AC/DC [AWG#42] 0.19A AC/DC [AWG#44] 0.15A AC/DC [AWG#46] ※ TESTING BY A REAL MACHINE IS RECOMENDED BECAUSE TEMPERATURE RISE MAY AFFECTED BY ACTUAL SITUATION
OPERATING TEMPERATURE	233~358K(-40°C~+85°C)
OPERATING HUMIDITY	85% MAX.(NON-CONDENSING)
CONTACT RESISTANCE	INITIAL : 450mohm MAX.(AWG#39) 700mohm MAX.(AWG#42) 1080mohm MAX.(AWG#44) 1880mohm MAX.(AWG#46) AFTER TEST : $\triangle$ 40mohm MAX.
GROUND CONTACT RESISTANCE	INITIAL : 100mohm MAX. / AFTER TEST : $\triangle$ 40mohm MAX.
INSULATION RESISTANCE	INITIAL : 100Mohm MIN. / AFTER TEST : 100Mohm MIN.
DIELECTRIC WITHSTANDING VOLTAGE	AC100V 1min
DURABILITY	20 CYCLES
MATING FORCE (INITIAL / 20 CYCLES)	26P : 28.0N MAX. 32P : 34.5N MAX. 40P : 40.0N MAX. 50P : 50.0N MAX.
UNMATING FORCE (INITIAL / 20 CYCLES)	26P : 3.0N MIN. 32P : 3.0N MIN. 40P : 3.0N MIN. 50P : 3.0N MIN.
COPLANARITY	0.10MAX
CABLE RETENTION FORCE	15.0N MIN. (AWG# 44)
PRODUCT SPECIFICATION	PRS-1469
TEST REPORT	TR-09032
PACKING STANDARD	300-697
INSTRUCTION MANUAL	HIM-09006
ASSEMBLY MANUAL	ASM-09004
APPEARANCE CRITERIA No.	QLS-A***

ANGLE	$\pm 2^\circ$	6 OVER 30 MAX.	$\pm 0.3$	PROJECTION 	SERIES No. R3	CUSTOMER COPY		
	6 MAX.	$\pm 0.2$	30 OVER 120 MAX.					
GENERAL TOLERANCE.				TITLE CABLIN <sup>®</sup> -UA II RECEPTACLE ASSEMBLY	SCALE 5:1 UNIT mm			
DWG.	DATE							
CHK.								
APP.								
				DWG. No.	20498	SIZE	SHEET	REV.
						A3	2/6	20

	PART No.	Pos.	A	B	C	D	F
	20498-026E-##	26	12.4	10.8	8.1	3.6	8.9
	20498-032E-##	32	14.2	12.6	9.9	4.5	10.7
◆	20498-034E-##	34	14.8	13.2	10.5	4.8	11.3
	20498-040E-##	40	16.6	15.0	12.3	5.7	13.1
	20498-050E-##	50	19.6	18.0	15.3	7.2	16.1

◆ MARK MEANS NOT AVAILABLE (ALL)

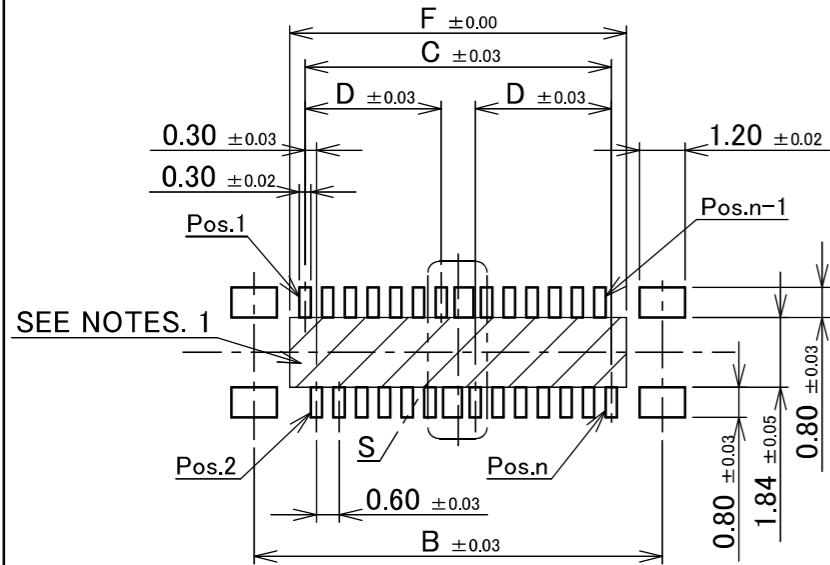

26P, 34P, 50P

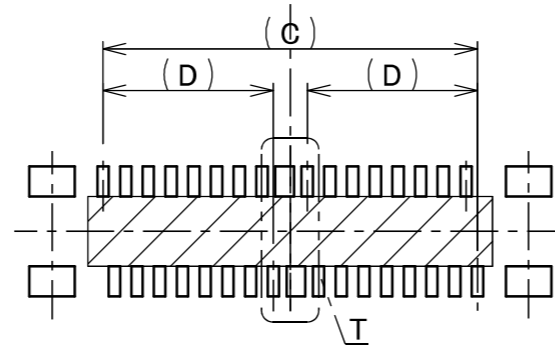

32P, 40P

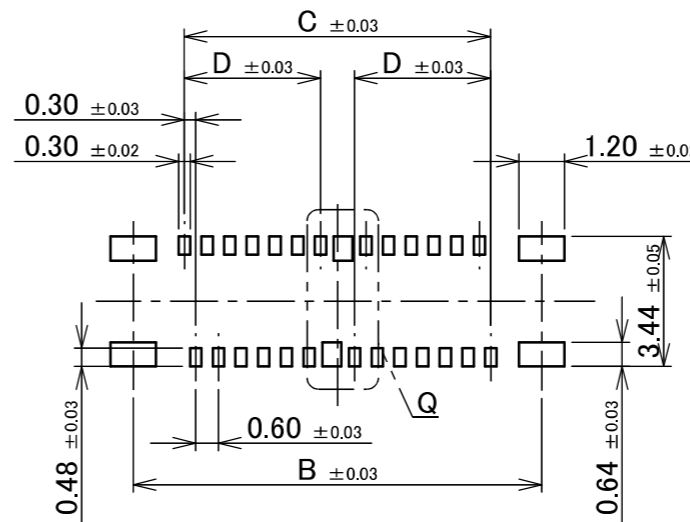

26P, 34P, 50P

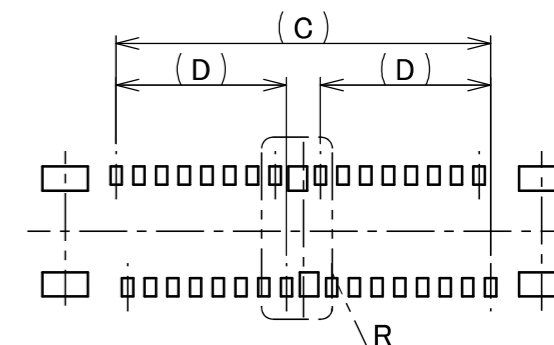

32P, 40P

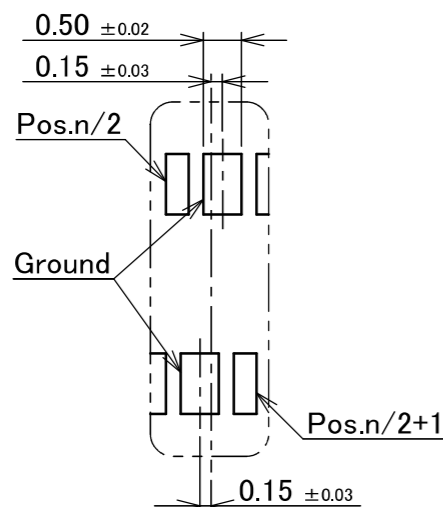

DETAIL S  
(S= 10/1)

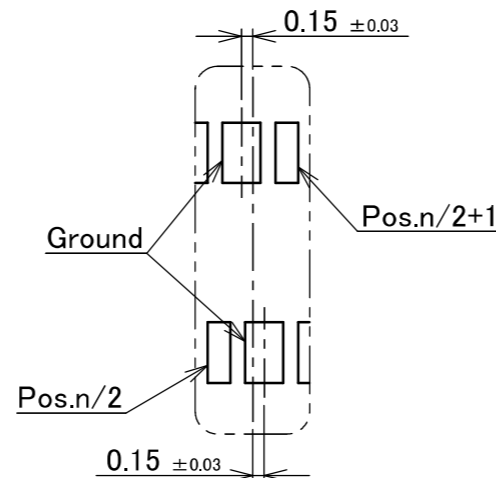

DETAIL T  
(S= 10/1)

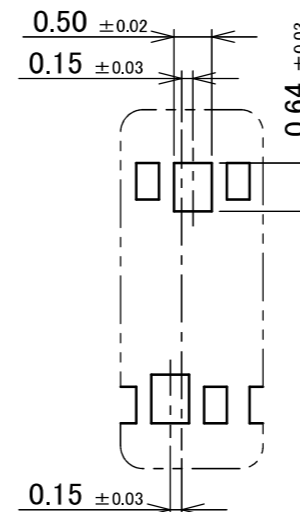

DETAIL Q  
(S= 10/1)

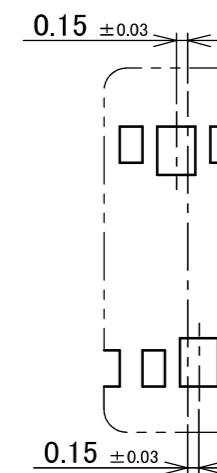

DETAIL R  
(S= 10/1)

RECOMMENDED FOOTPRINT PATTERN LAYOUT

RECOMMENDED FOOTPRINT METAL MASK LAYOUT  
METAL MASK THICKNESS : t=0.12 mm

NOTES.  
1. SOLDER RESIST MUST BE APPLIED TO THIS AREA

ANGLE	±2°	6 OVER 30 MAX.	±0.3	PROJECTION ⊕	SERIES No. R3	CUSTOMER COPY				
	6 MAX.	±0.2	30 OVER 120 MAX.					±0.5		
GENERAL TOLERANCE.				TITLE CABLIN®-UA II RECEPTACLE ASSEMBLY	SCALE 5:1	I-PEX				
DWG.	DATE							UNIT mm		
CHK.								SIZE A3	SHEET 3/6	REV. 20
APP.								DWG. No. 20498		

	PART No.	Pos.	G
	20498-026E-##	26	12.0
	20498-032E-##	32	13.8
◆	20498-034E-##	34	14.4
	20498-040E-##	40	16.2
	20498-050E-##	50	19.2

◆ MARK MEANS NOT AVAILABLE (ALL)

PATTERN A : WHEN USING A DOUBLE-SIDE REMOVAL JIG

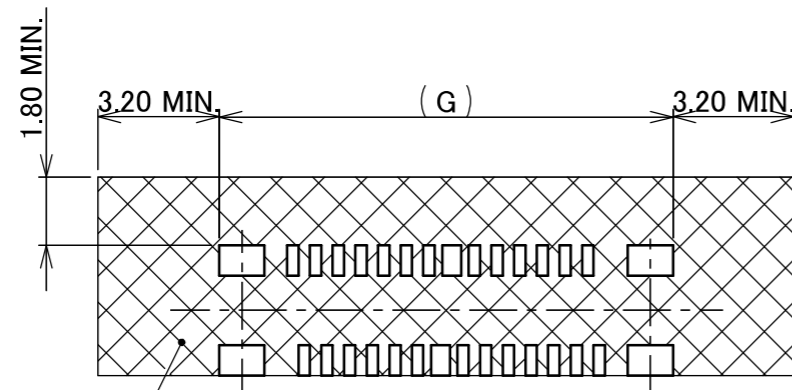

COMPONENT MOUNTING PROHIBITION AREA PATTERN A

PATTERN B : WHEN USING A SINGLE-SIDED REMOVAL JIG

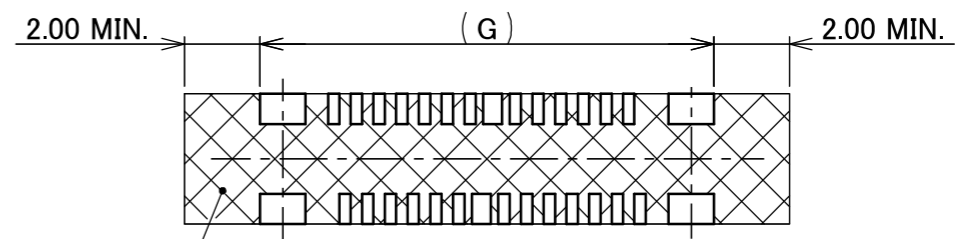

COMPONENT MOUNTING PROHIBITION AREA PATTERN B

COMPONENT MOUNTING PROHIBITION AREA

ANGLE	±2°	6 OVER 30 MAX.	±0.3	PROJECTION ⊕	SERIES No. R3	CUSTOMER COPY		
6 MAX.	±0.2	30 OVER 120 MAX.	±0.5					
GENERAL TOLERANCE.				TITLE CABLIN <sup>®</sup> -UA II RECEPTACLE ASSEMBLY	SCALE 5:1 UNIT mm	I-PEX		
DWG.	DATE							
CHK.								
APP.								
				DWG. No.	20498	SIZE A3	SHEET 4/6	REV. 20

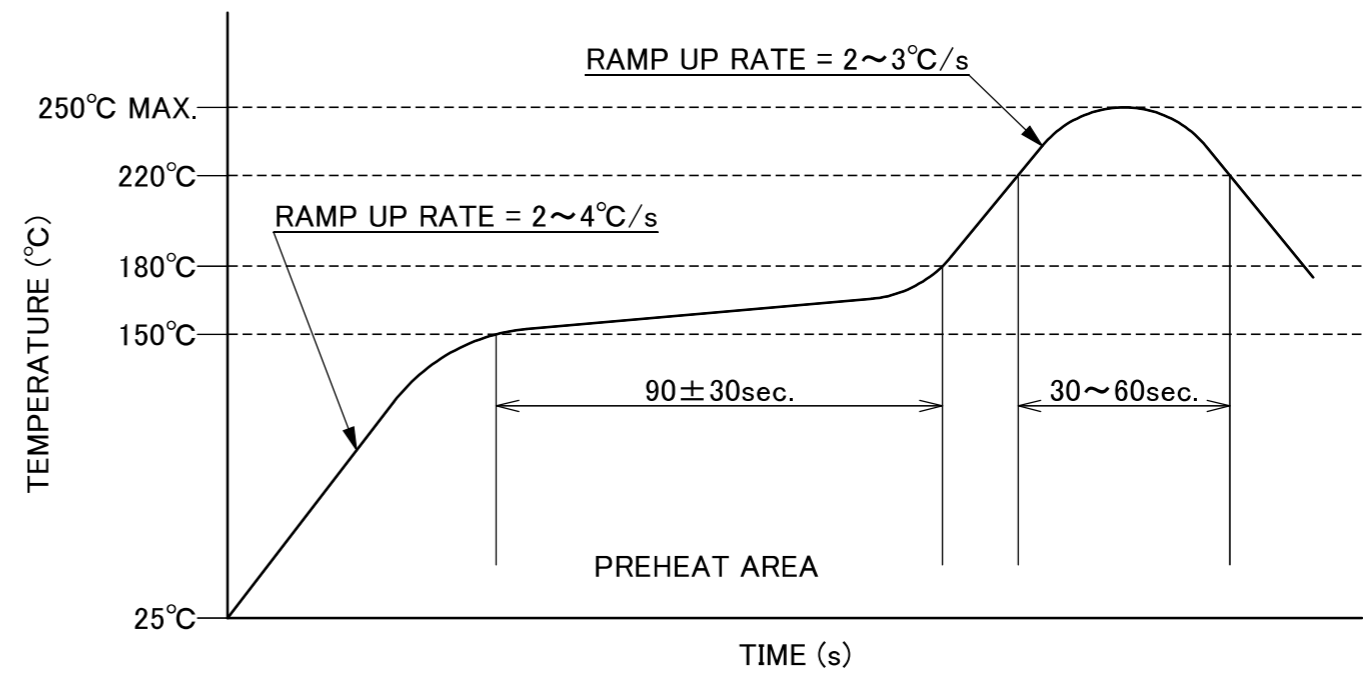
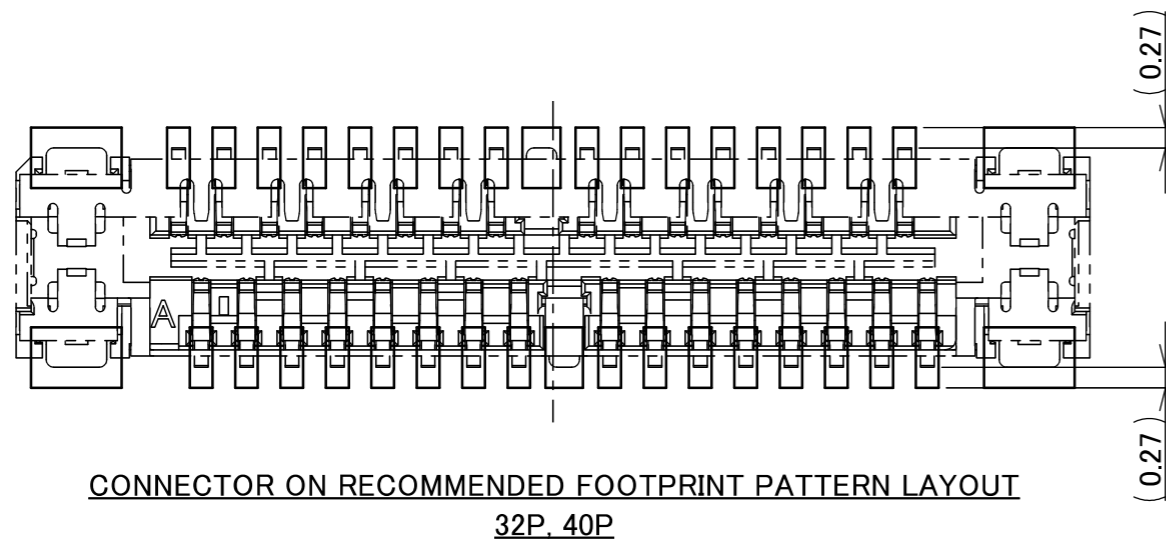
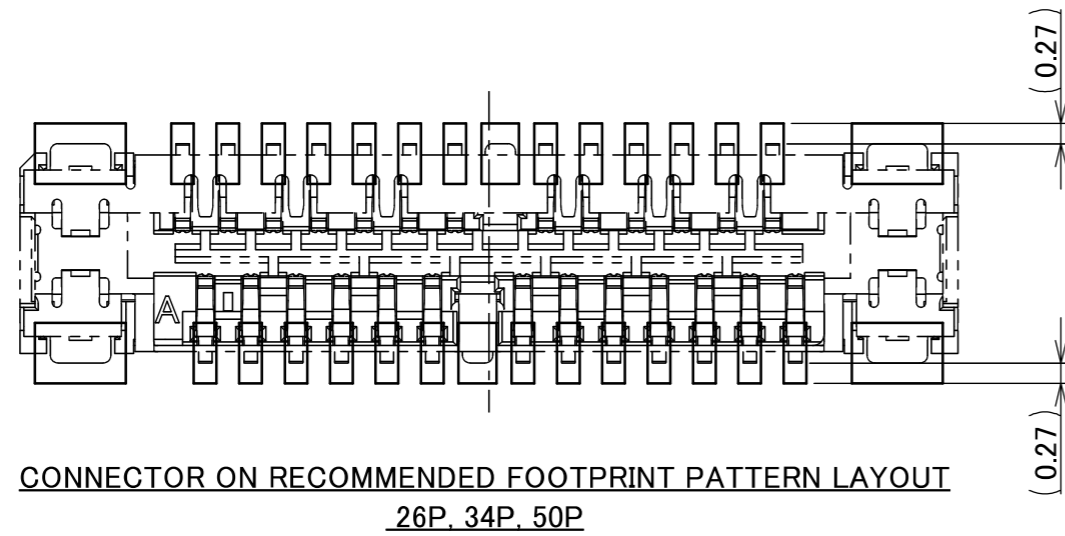

REFLOW TEMPERATURE PROFILE  
SENJU METAL INDUSTRY CO., LTD. : M705-SHF(Sn96.5 Ag3.0 Cu0.5)

ANGLE	±2°	6 OVER 30 MAX.	±0.3	PROJECTION ⊕	SERIES No. R3	CUSTOMER COPY			
6 MAX.	±0.2	30 OVER 120 MAX.	±0.5						
GENERAL TOLERANCE.				TITLE		SCALE	<b>I-PEX</b>		
DWG.	DATE			CABLIN <sup>®</sup> -UA II RECEPTACLE ASSEMBLY		10:1			
CHK.						UNIT			
APP.						mm			
				DWG. No.	20498	SIZE	SHEET	REV.	
						A3	5/6	20	

	DEVICE P/N	F	G	H	J	K	L	M	QTY. PER EMBOSS REEL (PIECES / REEL)	QTY. PER PACKING CARTON (REELS / CARTON)
	20498-026E-##	21.3	24.0	11.5	-	13.4	12.8	9.35	5000 / REEL	4 / CARTON = 20000
	20498-032E-##	21.3	24.0	11.5	-	15.2	14.6	11.15	5000 / REEL	4 / CARTON = 20000
◆	20498-034E-##	21.3	24.0	11.5	-	15.8	15.2	11.75	5000 / REEL	4 / CARTON = 20000
	20498-040E-##	26.0	32.0	14.2	28.4	17.6	17.0	13.55	5000 / REEL	3 / CARTON = 15000
	20498-050E-##	26.0	32.0	14.2	28.4	20.6	20.0	16.55	5000 / REEL	3 / CARTON = 15000

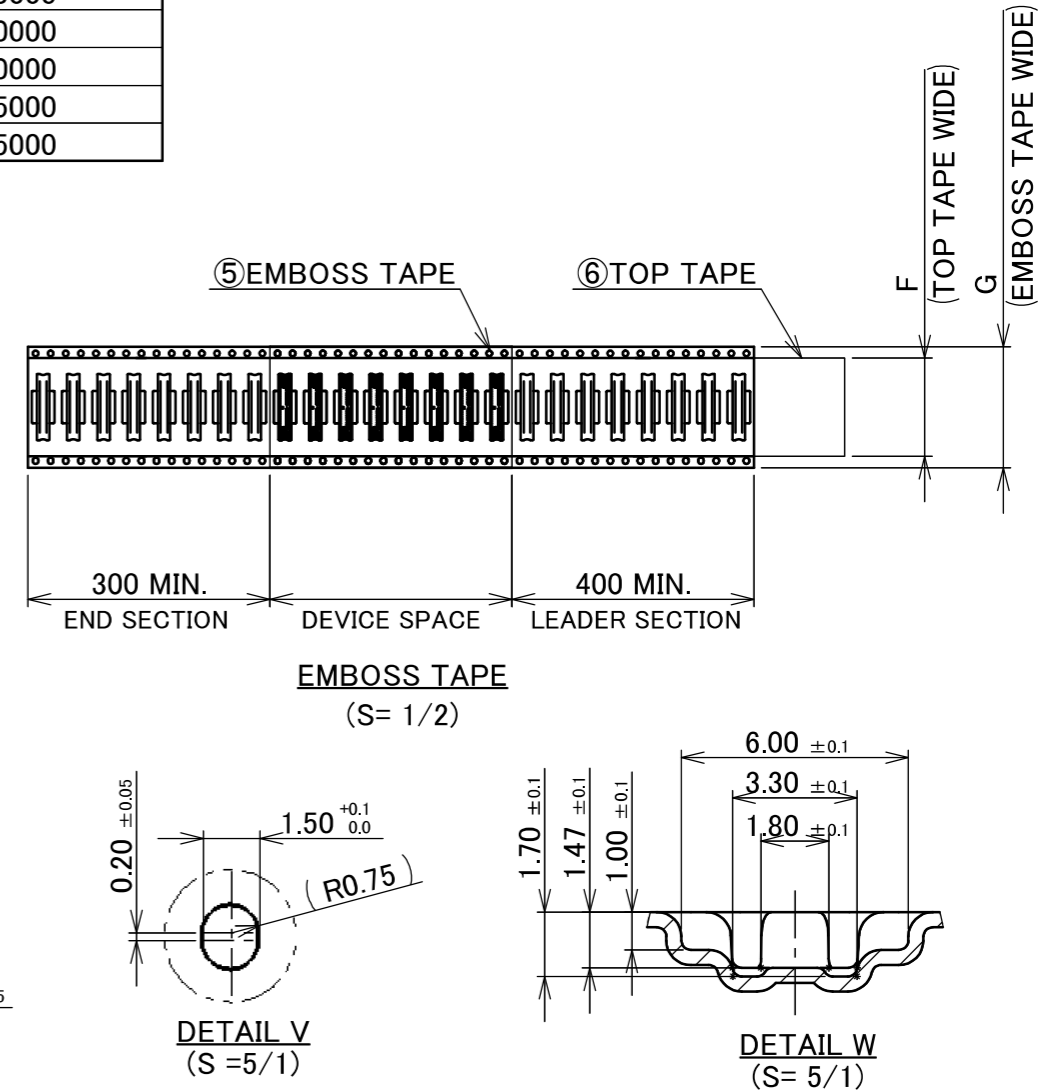
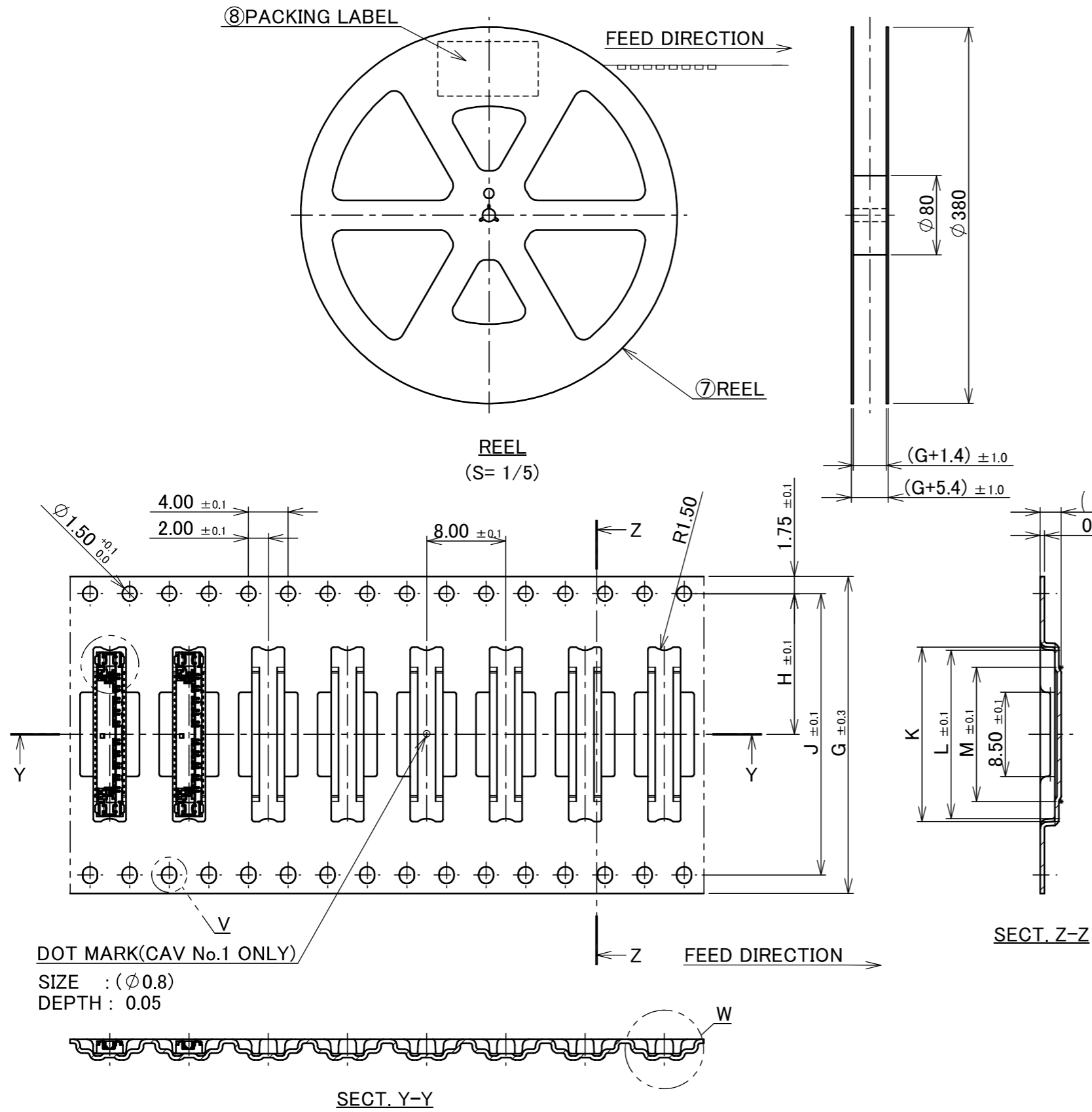

NOTES.  
 2. TAPING SPECIFICATION FOLLOWS JIS C 0806 (IEC 60286-3).  
 3. MAKE EMPTY SECTION OF LEADER AND END ON EACH END OF THE TAPE.  
 4. TOP TAPE SHALL NOT STICK OUT FROM EMBOSS TAPE.  
 5. TOP TAPE SHALL NOT COVER FEED HOLE.

NO.	DISCRIPTION	MATERIAL	FINISH , REMARKS
8	PACKING LABEL	-	-
7	REEL	PS	ANTI-STATIC TYPE BLACK
6	TOP TAPE	PET TRANSPARENCY	ANTI-STATIC TYPE ADHESIVE TYPE
5	EMBOSS TAPE	PS TRANSPARENCY	ANTI-STATIC TYPE

ANGLE	±2°	6 OVER 30 MAX.	±0.3	PROJECTION	SERIES No.	CUSTOMER COPY		
6 MAX.	±0.2	30 OVER 120 MAX.	±0.5		R3			
GENERAL TOLERANCE.				TITLE	SCALE	<b>I-PEX</b>		
DWG.	DATE		CABLIN®-UA II RECEPTACLE ASSEMBLY	2:1				
CHK.				UNIT				
APP.				mm				
				DWG. No.	SIZE	SHEET	REV.	
				20498	A3	6/6	20	