

Recommended P/N 20498-0**E-41

PART No.	Pos.	A	B	C	D	E
20498-026E-##	26	12.4	10.8	8.1	3.6	6.7
20498-032E-##	32	14.2	12.6	9.9	4.5	10.9
◆ 20498-034E-##	34	14.8	13.2	10.5	4.8	11.5
20498-040E-##	40	16.6	15.0	12.3	5.7	10.9
20498-050E-##	50	19.6	18.0	15.3	7.2	11.5

◆ MARK MEANS NOT AVAILABLE

20498-0**E-##
 0 : WITHOUT VACUUM CLIP
 1 : WITH VACUUM CLIP
 3 : SHELL Au PLATING
 4 : SHELL Sn PLATING
 Pos.



Halogen Free



RoHS Compliant

PART COMBINATION TABLE	
RECEPTACLE ASS'Y	PLUG CABLE ASS'Y
20498-0**E-3#	20496-0**-30
20498-0**E-4#	20496-0**-40

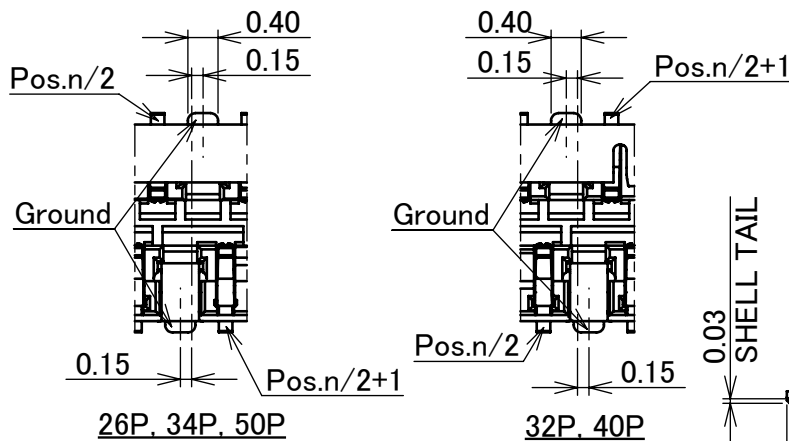
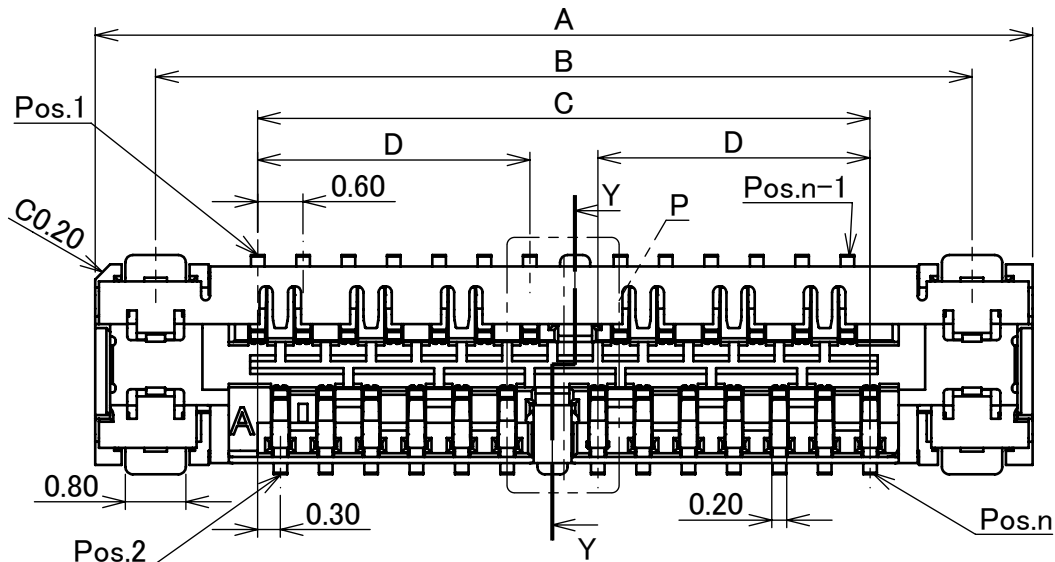
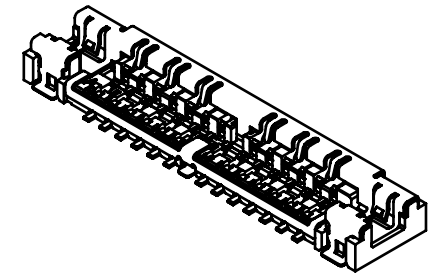

DETAIL P

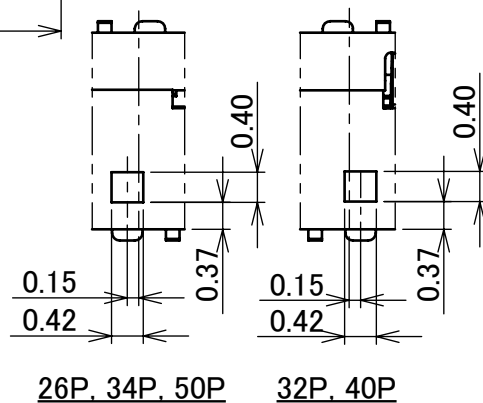
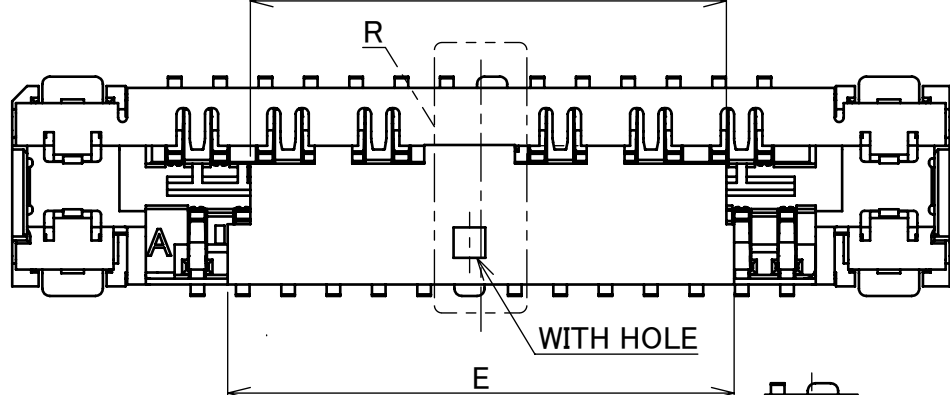
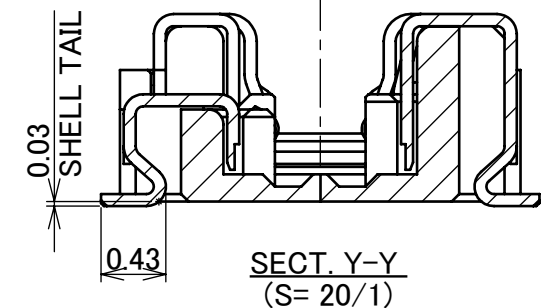
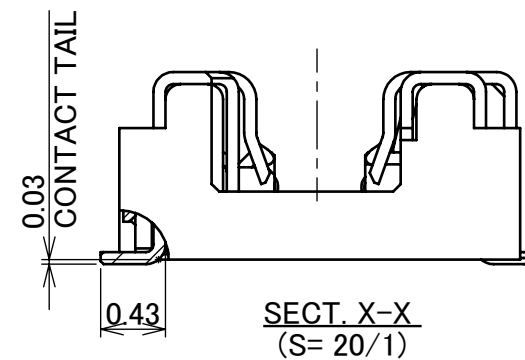
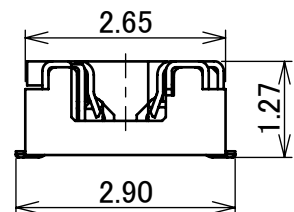
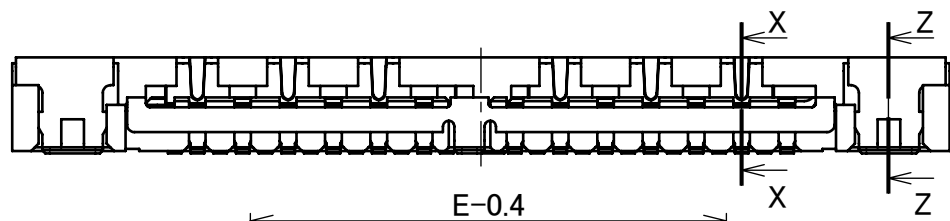
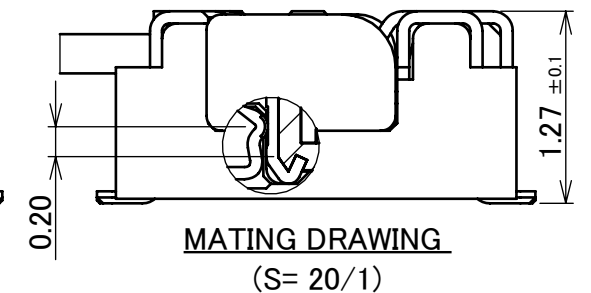
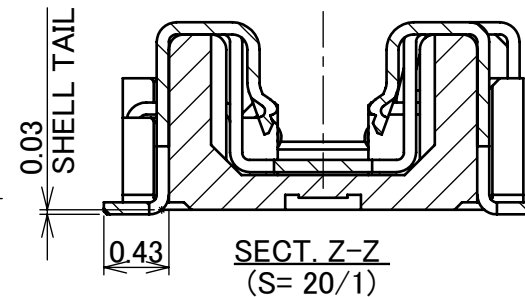

DETAIL R

NO.	DISCRIPTION	MATERIAL	FINISH , REMARKS
4	VACUUM CLIP	LCP	UL94V-0
3	SHELL	PHOSPHOR BROMZE	P/N 20498-0**E-3#: Au 0.02 μ m MIN. OVER Ni 1.00 μ m MIN. P/N 20498-0**E-4#: Sn 2.00 μ m MIN. OVER Ni 1.00 μ m MIN.
2	CONTACT	PHOSPHOR BRONZE	ALL OVER : Ni 1.00 μ m MIN. CONTACT AREA : Au 0.1 μ m MIN. SOLDERING AREA : Au 0.05 μ MIN.
1	HOUSING	LCP	UL94V-0



REV.	ECN	BY	DATE	APP.	APP.	DATE	DWG. No.	SIZE	SHEET	REV.
18	Z220216	S.Y	2022/03/02	H.I	ANGLE	±2°	6 OVER 30 MAX.	±0.3		
17	Z211184	R.H	2021/09/30	H.I	6 MAX.	±0.2	30 OVER 120 MAX.	±0.5		
16	Z191021	S.Y	2019/08/01	H.I	GENERAL TOLERANCE.					
15	Z190779	S.Y	2019/06/12	H.I	DWG.	J.Ohsaka	DATE	2008/11/28		
14	Z181009	T.O	2018/07/31	H.I	CHK.					
13	Z180161	R.H	2018/02/08	M.T						
REV.	ECN	BY	DATE	APP.	APP.	E.Kawabe	DATE	2008/12/02	DWG. No.	20498

PROJECTION SERIES No. R3 CUSTOMER COPY

TITLE CABLINE® -UA II RECEPTACLE ASS'Y SCALE 10:1 UNIT mm SHEET 1/5 REV. 18

I-PEX

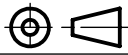
ITEMS	SPECIFICATION
APPLICABLE CABLE	MICRO COAX : AWG# 46 , 44 , 42 DISCRETE : AWG# 39
RATING VOLTAGE	50V AC (PER CONTACT)
RATING AMPERAGE (FOR CONTACT)	0.50A AC/DC [AWG#39] (PER CONTACT / UP TO 10 CONTACTS) 0.20A AC/DC [AWG#42] 0.19A AC/DC [AWG#44] 0.15A AC/DC [AWG#46] ※ TESTING BY A REAL MACHINE IS RECOMENDED BECAUSE TEMPERATURE RISE MAY AFFECTED BY ACTUAL SITUATION
OPERATING TEMPERATURE	233~358K(-40°C~+85°C)
OPERATING HUMIDITY	85% MAX.(NON-CONDENSING)
CONTACT RESISTANCE	INITIAL : 450mohm MAX.(AWG#39) 700mohm MAX.(AWG#42) 1080mohm MAX.(AWG#44) 1880mohm MAX.(AWG#46) AFTER TEST : \triangleleft 40mohm MAX.
GROUND CONTACT RESISTANCE	INITIAL : 100mohm MAX. / AFTER TEST : \triangleleft 40mohm MAX.
INSULATION RESISTANCE	INITIAL : 100Mohm MIN. / AFTER TEST : 100Mohm MIN.
DIELECTRIC WITHSTANDING VOLTAGE	AC100V 1min
DURABILITY	20 CYCLES
MATING FORCE (INITIAL / 20 CYCLES)	26P : 28.0N MAX. 32P : 34.5N MAX. 40P : 40.0N MAX. 50P : 50.0N MAX.
UNMATING FORCE (INITIAL / 20 CYCLES)	26P : 3.0N MIN. 32P : 3.0N MIN. 40P : 3.0N MIN. 50P : 3.0N MIN.
COPLANARITY	0.10MAX
CABLE RETENTION FORCE	15.0N MIN. (AWG# 44)
PRODUCT SPECIFICATION	PRS-1469
TEST REPORT	TR-09032
PACKING STANDARD	300-697
INSTRUCTION MANUAL	HIM-09006
ASSEMBLY MANUAL	ASM-09004
APPEARANCE CRITERIA No.	QLS-A***

ANGLE	$\pm 2^\circ$	6 OVER 30 MAX.	± 0.3	PROJECTION 	SERIES No. R3	CUSTOMER COPY		
6 MAX.	± 0.2	30 OVER 120 MAX.	± 0.5					
GENERAL TOLERANCE.				TITLE CABLIN [®] -UA II RECEPTACLE ASS'Y	SCALE 	I-PEX		
DWG.	DATE							
CHK.								
APP.								
				DWG. No.	20498	SIZE	SHEET	REV.
						A3	2/5	18

	PART No.	Pos.	A	B	C	D
	20498-026E-##	26	12.4	10.8	8.1	3.6
	20498-032E-##	32	14.2	12.6	9.9	4.5
◆	20498-034E-##	34	14.8	13.2	10.5	4.8
	20498-040E-##	40	16.6	15.0	12.3	5.7
	20498-050E-##	50	19.6	18.0	15.3	7.2

◆ MARK MEANS NOT AVAILABLE (ALL)

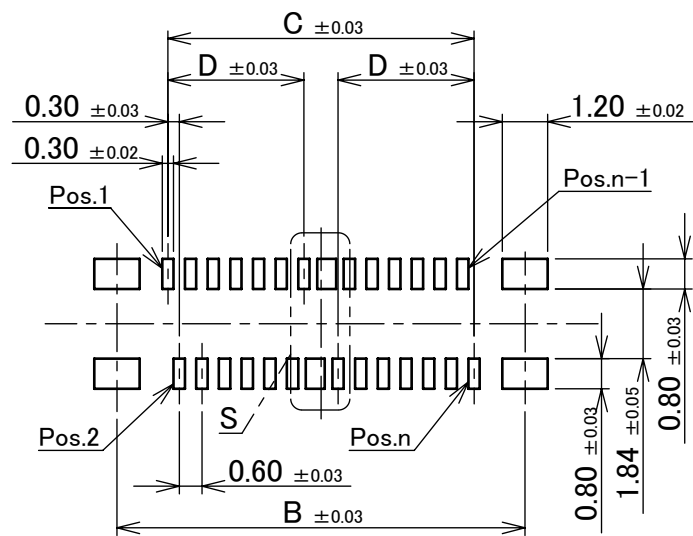

26P, 34P, 50P

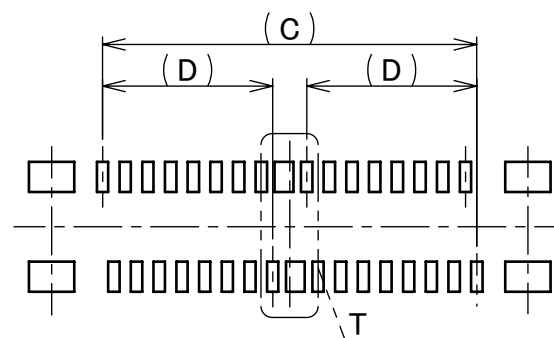

32P, 40P

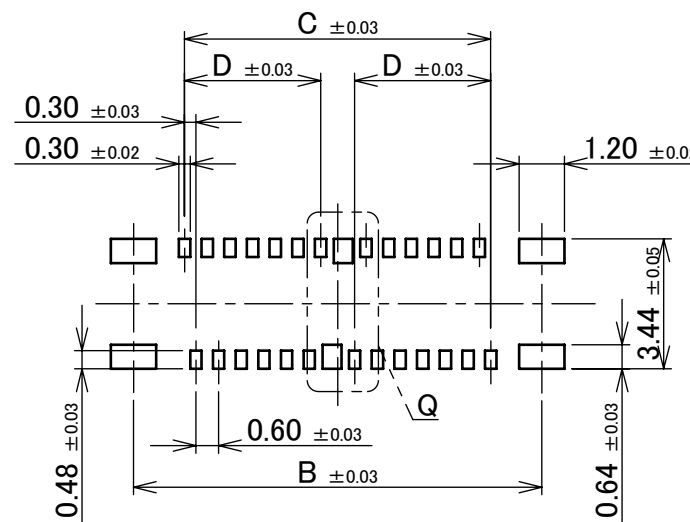

26P, 34P, 50P

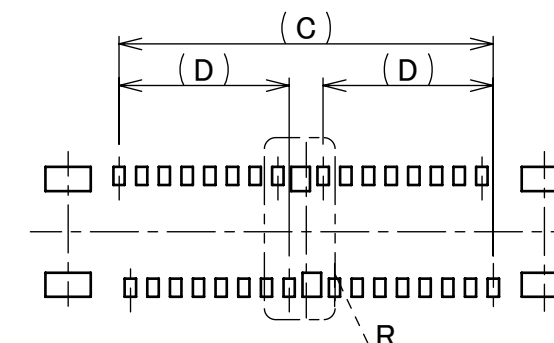

32P, 40P

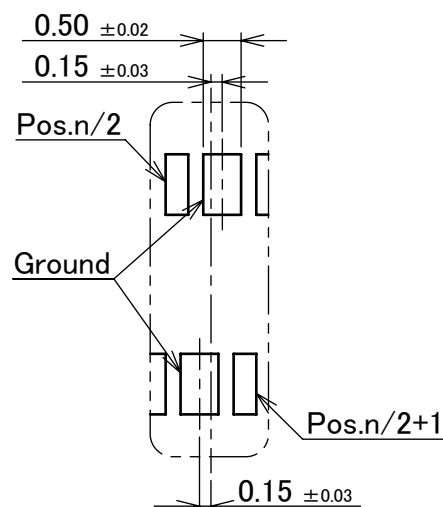

DETAIL S
(S= 10/1)

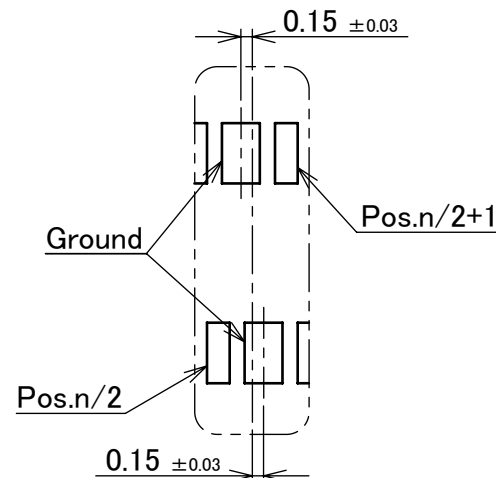

DETAIL T
(S= 10/1)

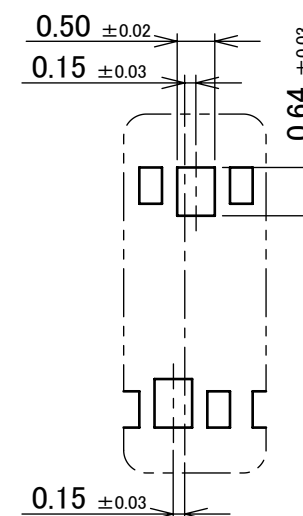

DETAIL Q
(S= 10/1)

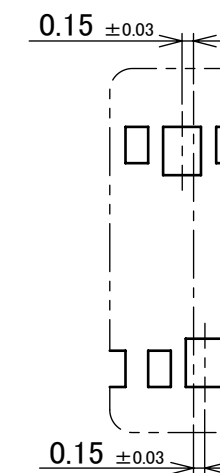

DETAIL R
(S= 10/1)

RECOMMENDED FOOTPRINT PATTERN LAYOUT

RECOMMENDED FOOTPRINT METAL MASK LAYOUT
METAL MASK THICKNESS : t=0.12 mm

- NOTES.
1. THIS AREA CANNOT MOUNT ANOTHER COMPONENTS.
 2. SOLDER RESIST SHALL BE APPLIED TO PREVENT SHORT CIRCUITS WHEN PLACING SIGNAL LINES ON GROUND AREA.

ANGLE	±2°	6 OVER 30 MAX.	±0.3	PROJECTION ⊕	SERIES No. R3	CUSTOMER COPY				
	6 MAX.	±0.2	30 OVER 120 MAX.					±0.5		
GENERAL TOLERANCE.				TITLE CABLINER [®] -UA II RECEPTACLE ASS'Y	SCALE 5:1	I-PEX				
DWG.	DATE							UNIT mm		
CHK.								SIZE A3	SHEET 3/5	REV. 18
APP.								DWG. No. 20498		

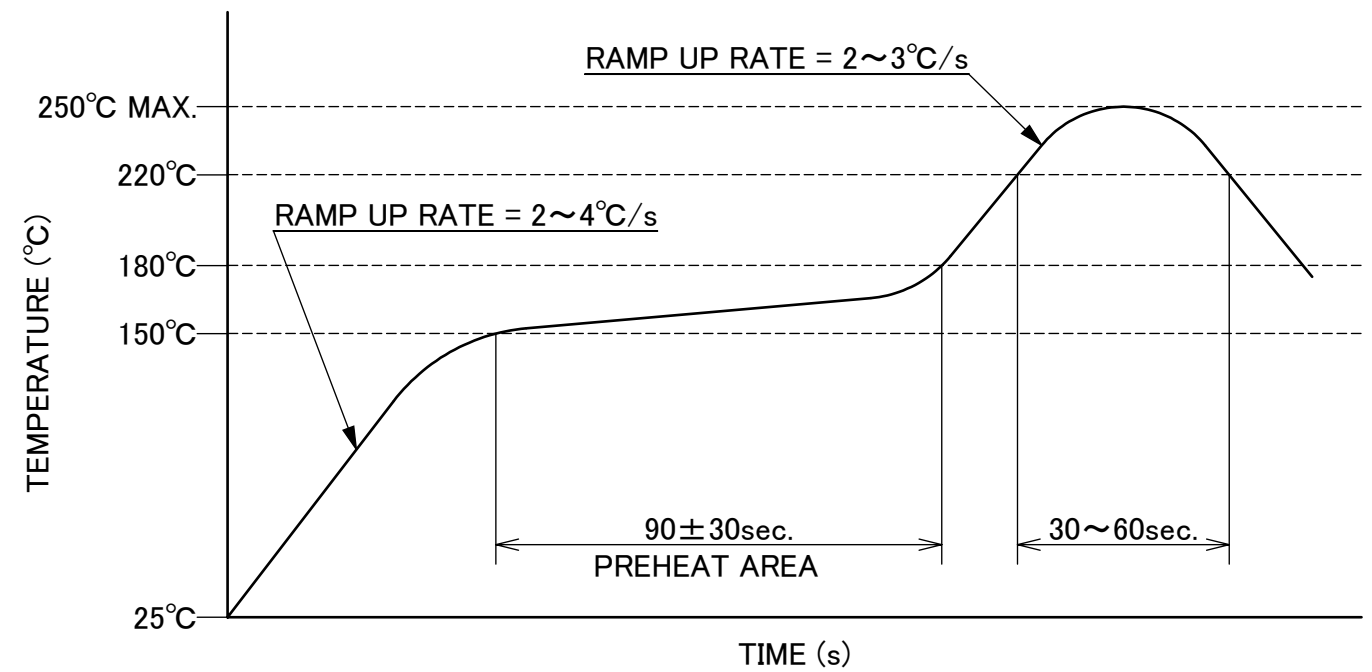
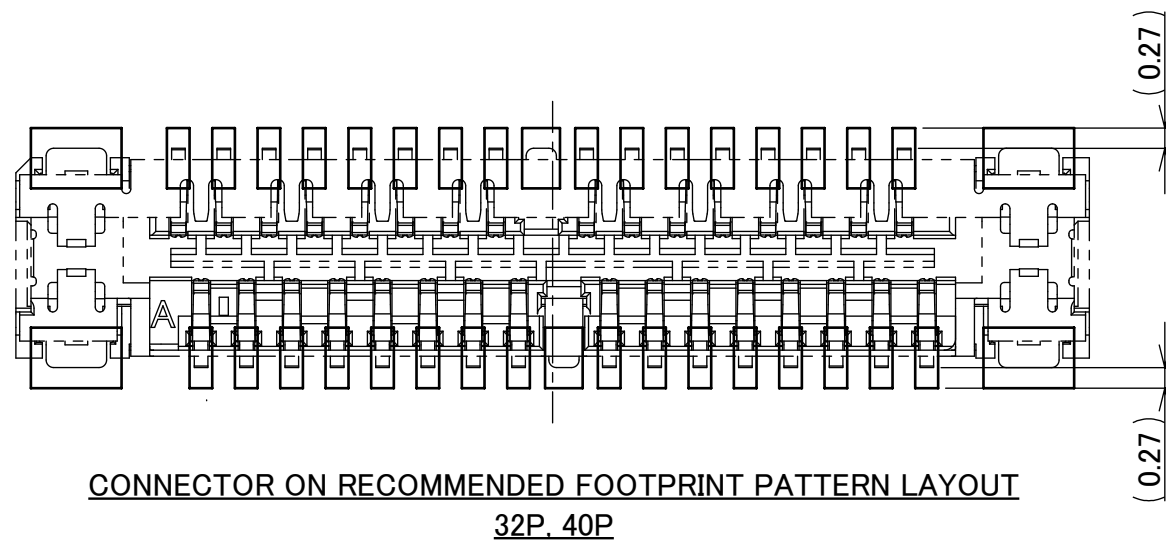
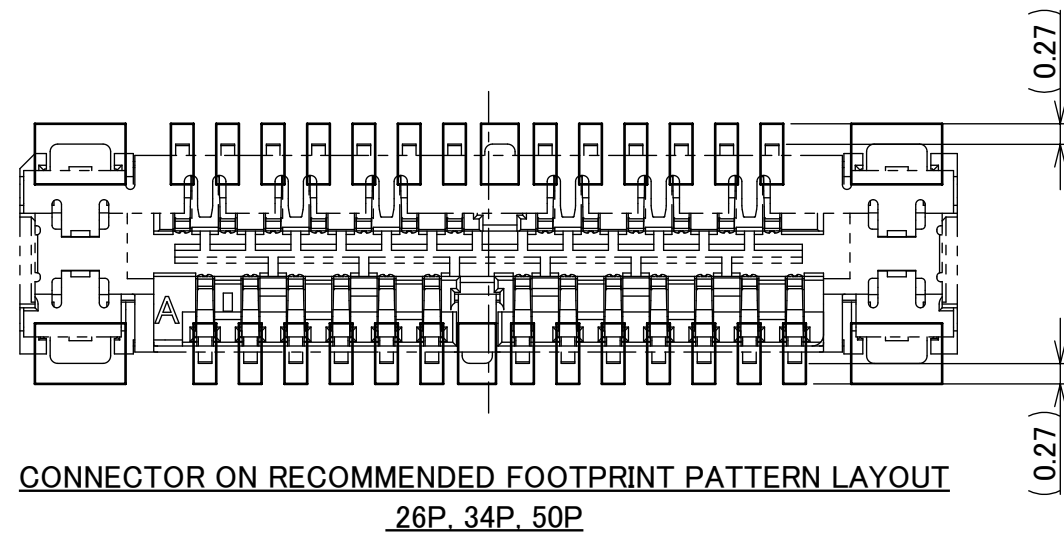

REFLOW TEMPERATURE PROFILE
SENJU METAL INDUSTRY CO., LTD. : M705-SHF(Sn96.5 Ag3.0 Cu0.5)

ANGLE	±2°	6 OVER 30 MAX.	±0.3	PROJECTION ⊕	SERIES No. R3	CUSTOMER COPY			
6 MAX.	±0.2	30 OVER 120 MAX.	±0.5						
GENERAL TOLERANCE.				TITLE		SCALE	I-PEX		
DWG.	DATE			CABLIN [®] -UA II RECEPTACLE ASS'Y		10:1			
CHK.						UNIT			
APP.						mm			
				DWG. No.	20498	SIZE	SHEET	REV.	
						A3	4/5	18	

	DEVICE P/N	F	G	H	J	K	L	M	QTY. PER EMBOSS REEL (PIECES / REEL)	QTY. PER PACKING CARTON (REELS / CARTON)
	20498-026E-##	21.3	24.0	11.5	-	13.4	12.8	9.35	5000 / REEL	4 / CARTON = 20000
	20498-032E-##	21.3	24.0	11.5	-	15.2	14.6	11.15	5000 / REEL	4 / CARTON = 20000
◆	20498-034E-##	21.3	24.0	11.5	-	15.8	15.2	11.75	5000 / REEL	4 / CARTON = 20000
	20498-040E-##	26.0	32.0	14.2	28.4	17.6	17.0	13.55	5000 / REEL	3 / CARTON = 15000
	20498-050E-##	26.0	32.0	14.2	28.4	20.6	20.0	16.55	5000 / REEL	3 / CARTON = 15000

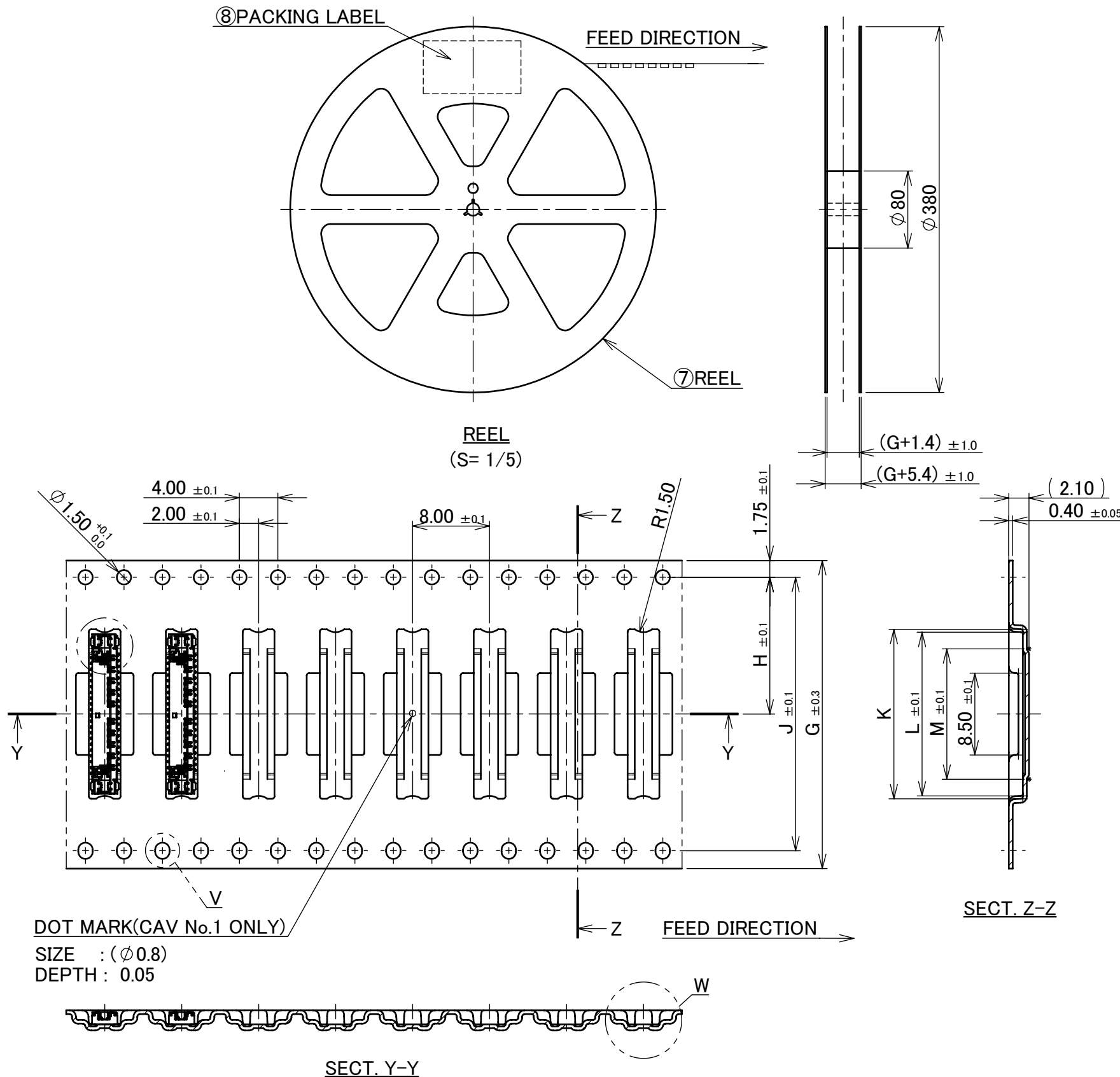

- NOTES.
- TAPING SPECIFICATION FOLLOWS JIS C 0806 (IEC 60286-3).
 - MAKE EMPTY SECTION OF LEADER AND END ON EACH END OF THE TAPE.
 - TOP TAPE SHALL NOT STICK OUT FROM EMBOSS TAPE.
 - TOP TAPE SHALL NOT COVER FEED HOLE.

NO.	DISCRIPTION	MATERIAL	FINISH , REMARKS
8	PACKING LABEL	-	-
7	REEL	PS	ANTI-STATIC TYPE BLACK
6	TOP TAPE	PET t=0.061 TRANSPARENCY	ANTI-STATIC TYPE ADHESIVE TYPE
5	EMBROSS TAPE	PS t=0.4 TRANSPARENCY	ANTI-STATIC TYPE

ANGLE	±2°	6 OVER 30 MAX.	±0.3	PROJECTION	SERIES No.	CUSTOMER COPY
6 MAX.	±0.2	30 OVER 120 MAX.	±0.5		R3	
GENERAL TOLERANCE.				TITLE	DWG. No. 20498	SCALE
DWG.	DATE	CABLINER® -UA II RECEPTACLE ASS'Y		2:1		
CHK.	DATE			UNIT		
APP.	DATE			mm		
				DWG. No.	20498	SIZE
						A3
						SHEET
						5/5
						REV.
						18