

Recommended P/N		2679-0**-10			
PART NO.	POS.	A	B	C	
2679-026-#0	26	11.5	6.0	9.6	
2679-032-#0	32	13.3	7.0	11.4	
◆ 2679-034-#0	34	13.9	8.0	12.0	
2679-040-#0	40	15.7		13.8	
2679-050-#0	50	18.7	12.0	16.8	

◆ MARK MEANS NOT AVAILABLE.

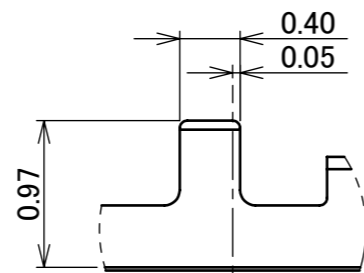

32P, 40P

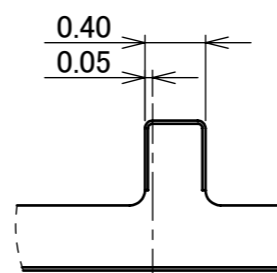

26P, 34P, 50P

DETAIL P
(S= 20/1)

2679-0**-#0
 0: METAL COVER Au PLATING
 1: METAL COVER Sn PLATING
 Pos.

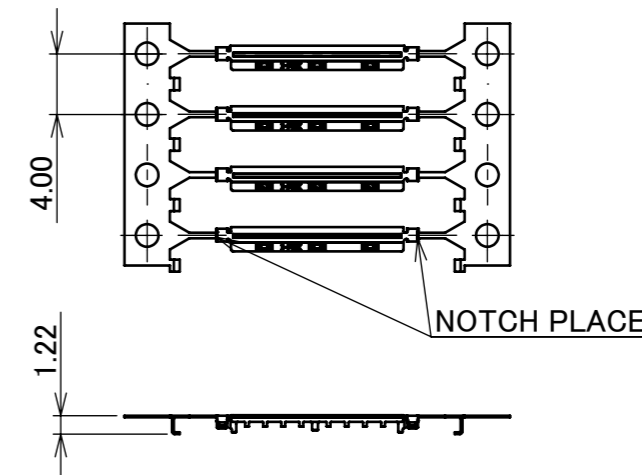
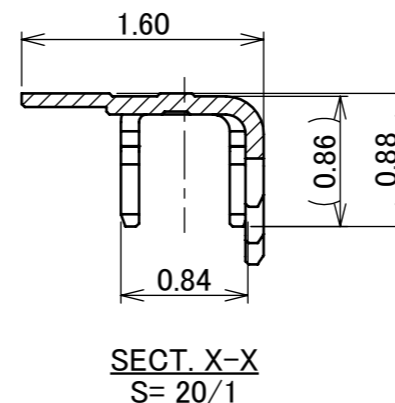
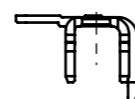
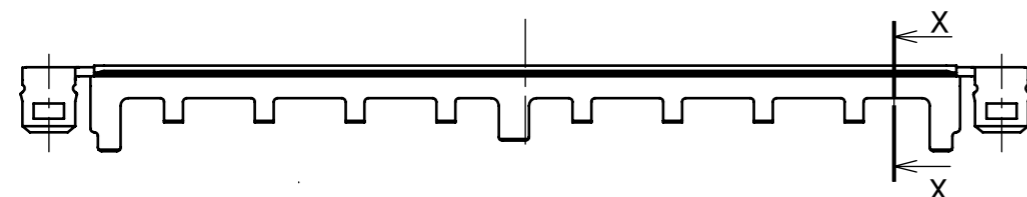
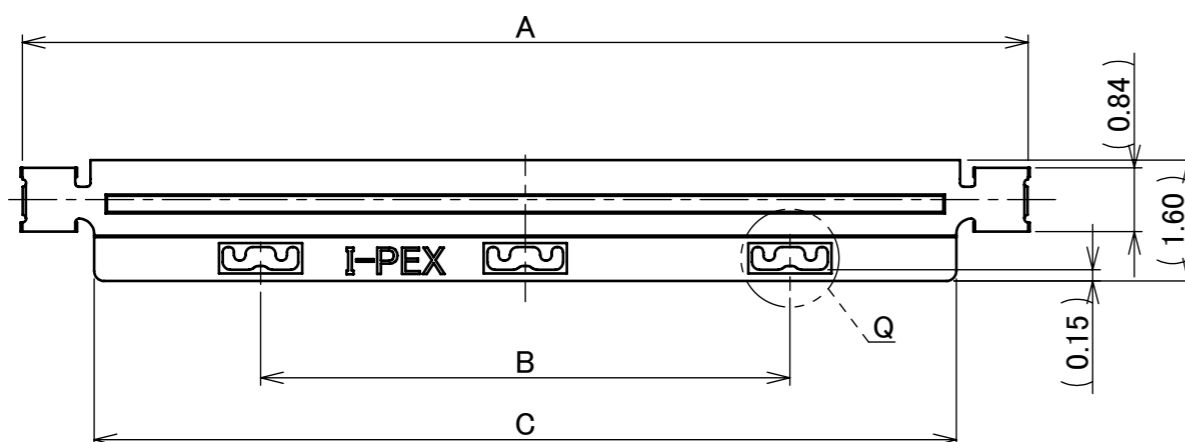
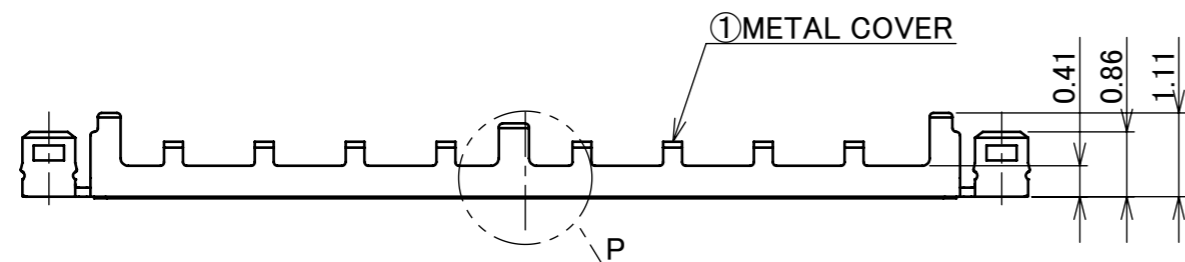

WITH CARRIER
(S= 2/1)

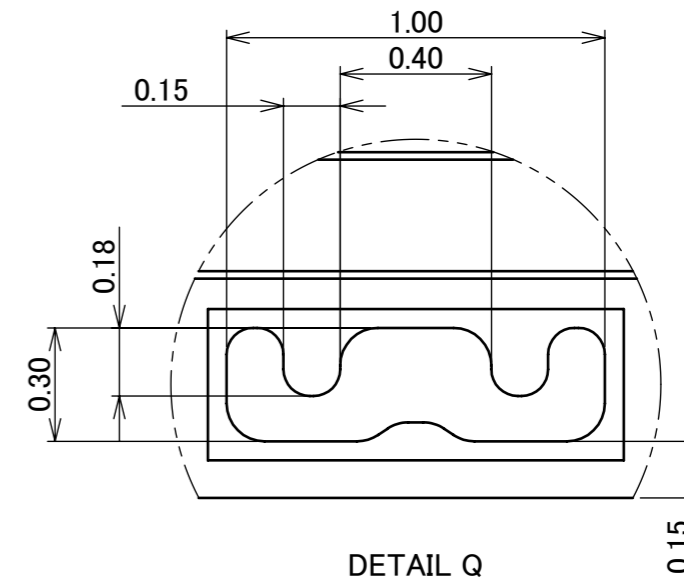

DETAIL Q
(S= 50/1)

NO.	DISCRIPTION	MATERIAL	FINISH , REMARKS
1	METAL COVER	STAINLESS STEEL	t=0.12 P/N 2679-0**-00: Au 0.05 μ m MIN. OVER Ni 1.00 μ m MIN. P/N 2679-0**-10: Sn 1.00 μ m MIN. OVER Ni 1.00 μ m MIN.

NOTES

1. APPLICABLE PLUG HOUSING ASS'Y
P/N 20497-0**T-30
2. PRODUCT SPECIFICATION : DOCUMENT No. PRS-1469
ASSEMBLY MANUAL : DOCUMENT No. ASM-09004

REV.	ECN	BY	DATE	APP.	APP.	DATE	DWG. No.	SIZE	SHEET	REV.
8	Z191190	S.Y	Sept./06/'19	H.I	ANGLE	±2°	6 OVER 30 MAX.	±0.3	PROJECTION	CUSTOMER COPY
7	Z181009	T.O	July/31/'18	H.I	6 MAX.	±0.2	30 OVER 120 MAX.	±0.5	⊕	
6	Z180289	R.H	Mar./06/'18	M.T	GENERAL TOLERANCE.			TITLE	SCALE	I-PEX
5	Z141362	T.U	Dec./05/'14	Tom	DWG.	DATE	CABLIN®-UA II PLUG METAL COVER	10:1		
4	Z131176	S.K	Dec./25/'13	Tom	J.Ohsaka	2009/02/17		UNIT	mm	
3	Z12116	J.O	Feb./20/'12	E.K	CHK.	DATE	SIZE	A3		
REVISION RECORD					E.Kawabe	2009/02/17	2679	SHEET	1/2	REV. 8

	PART NO.	POS.	D	E	REEL QTY.	QTY. (1 REEL)	QTY. IN PACKING CARTON (1 CARTON)	PACKING STANDARD
	2679-026-#0	26	21.00	25.00	4 REELS		15000 × 4 = 60000	
	2679-032-#0	32	23.00	30.00	3 REELS	15000	15000 × 3 = 45000	300-696
◆	2679-034-#0	34	23.00	30.00				
	2679-040-#0	40	25.50	30.00				
	2679-050-#0	50	28.50	35.00				

◆ MARK MEANS NOT AVAILABLE.

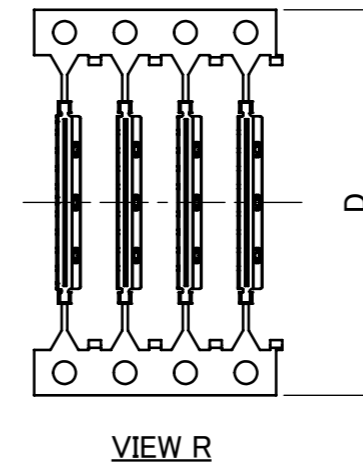
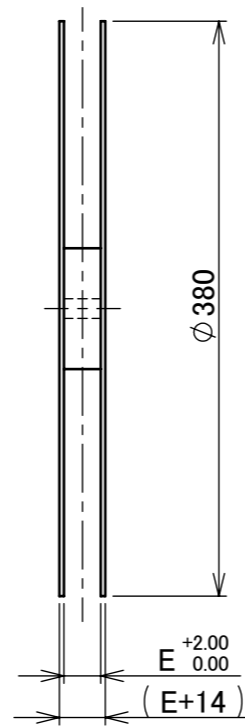
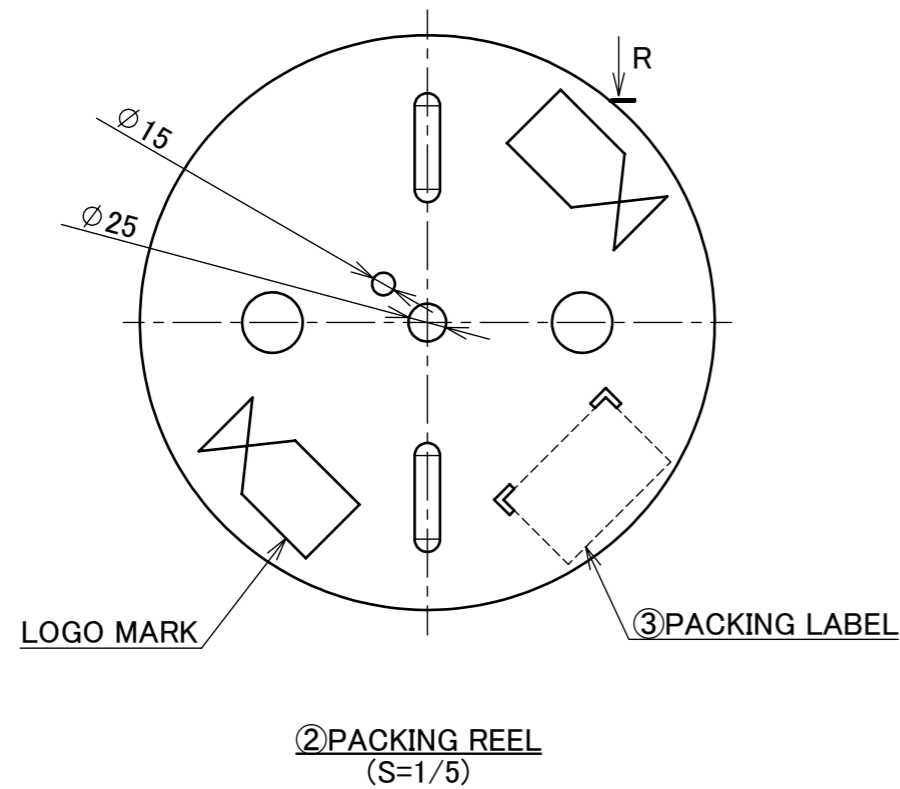

3	PACKING LABEL	-	-
2	PACKING REEL	CARDBOARD	-
NO.	DISCRIPTION	MATERIAL	FINISH , REMARKS

ANGLE	$\pm 2^\circ$	6 OVER 30 MAX.	± 0.3	PROJECTION 	SERIES No. R1	CUSTOMER COPY
6 MAX.	± 0.2	30 OVER 120 MAX.	± 0.5			
GENERAL TOLERANCE.				TITLE CABLIN [®] -UA II PLUG METAL COVER	SCALE X:1	UNIT mm
DWG.	DATE					
CHK.	DATE					
APP.	DATE					
				DWG. No.	2679	SIZE A3
				SHEET 2/2		REV. 8