

Recommended P/N 2182-0**-03 (10P / 14P / 20P / 30P / 32P / 35P) 2182-0**-04 (40P / 50P)

PART NO.	POS.	A	B	C
2182-010-03	10	7.84	-	24.50
2182-014-03	14	9.44	-	24.50
2182-020-03	20	11.84	-	24.50
2182-030-03	30	15.84	8.90	28.50
2182-032-03	32	16.64	9.70	29.30
2182-035-03	35	17.84	10.90	30.50

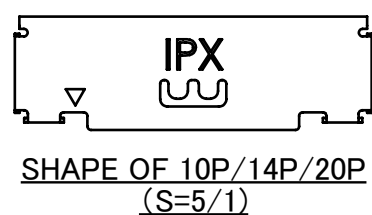
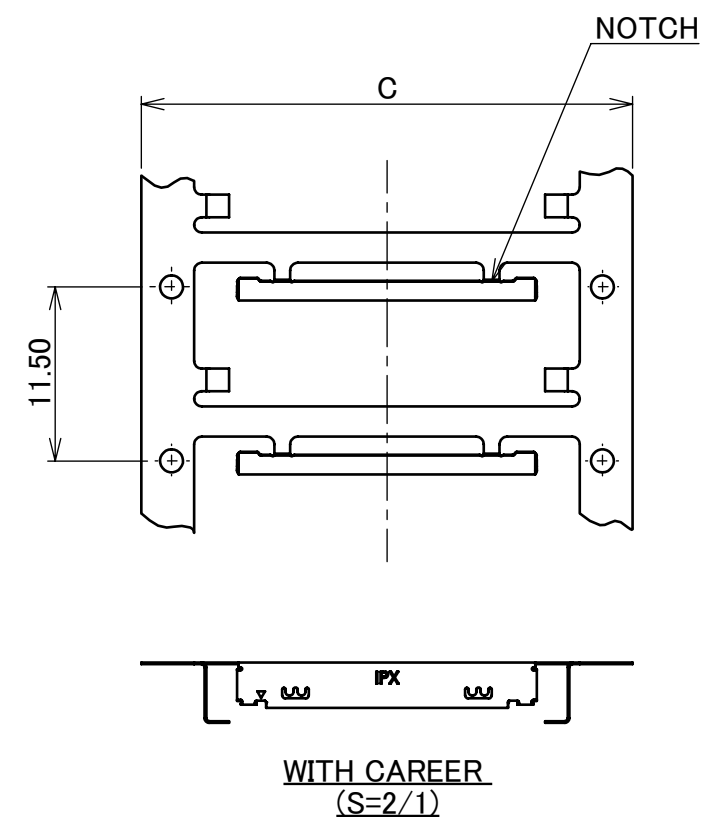
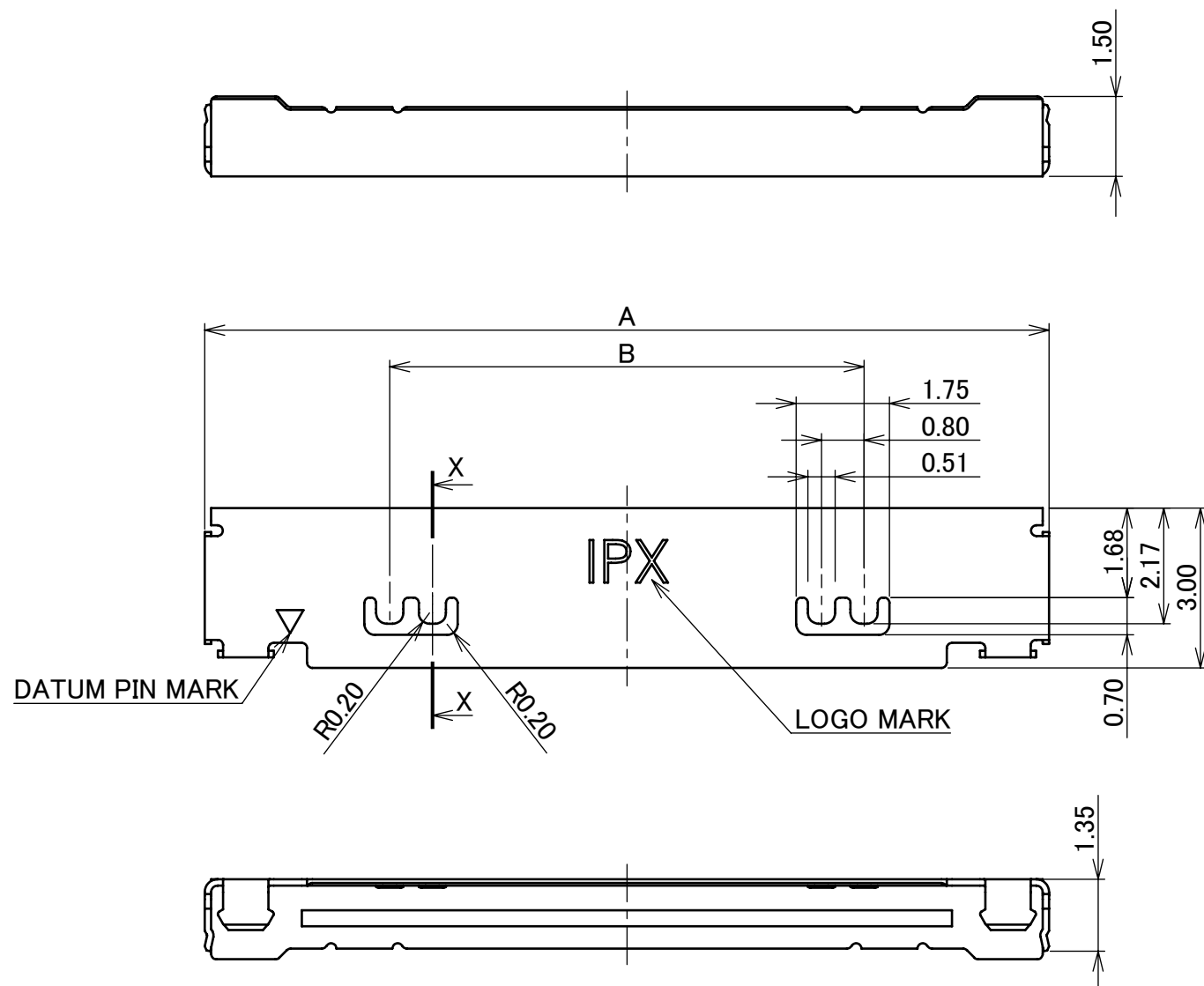
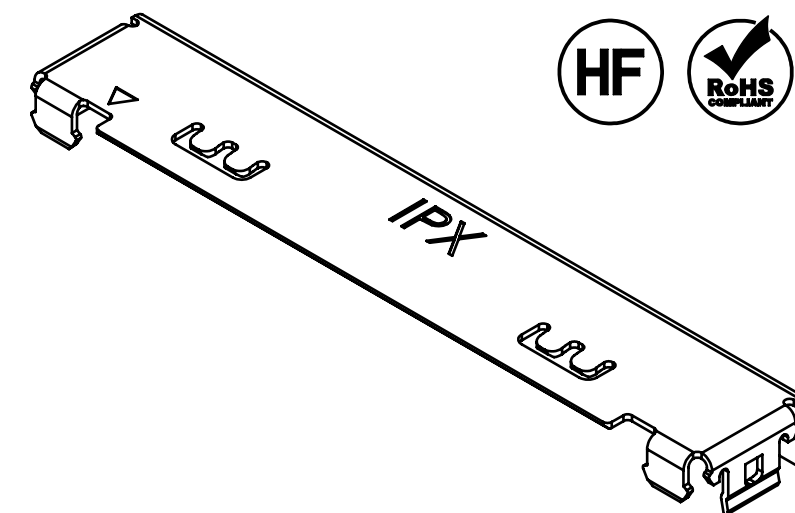

NO.	DESCRIPTION	MATERIAL	FINISH, REMARKS
1	METAL COVER	PHOSPHOR BRONZE	Sn REFLOW 1.00 μm MIN.

REV.	ECN	BY	DATE	APP.	APP.	DWG. No.	SIZE	SHEET	REV.
19	Z210420	T.T	Apr./21/'21	H.I	ANGLE ±2°	6 OVER 30 MAX.	±0.3		
18	Z201169	K.Hara	Nov./10/'20	Y.S	6 MAX. ±0.2	30 OVER 120 MAX.	±0.5		
17	Z191219	K.Hara	Sept./12/'19	H.I	GENERAL TOLERANCE.				
16	Z181296	H.K	Oct./24/'18	Y.S	DWG. K.Narita	DATE 2004/04/22			
15	Z171057	R.H	Sept./12/'17	M.T	CHK. M.Matsuo				
14	Z160023	K.H	Jan./13/'16	K.N	APP. T.Harada				

Recommended P/N 2182-0**-03 (10P / 14P / 20P / 30P / 32P / 35P) 2182-0**-04 (40P / 50P)

PART NO.	POS.	A	B	C	D
2182-040-04	40	19.84	12.90	32.50	4.84
2182-050-04	50	23.84	16.90	36.50	6.17

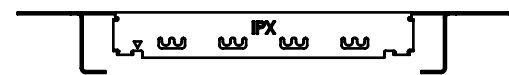
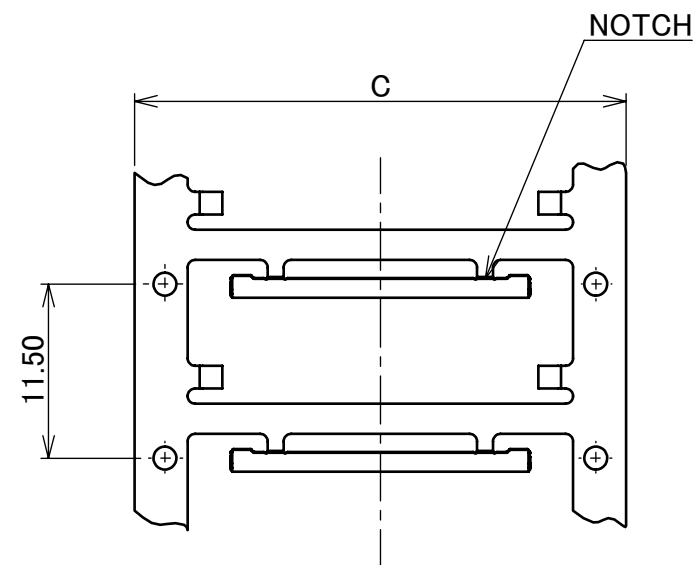
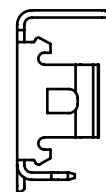
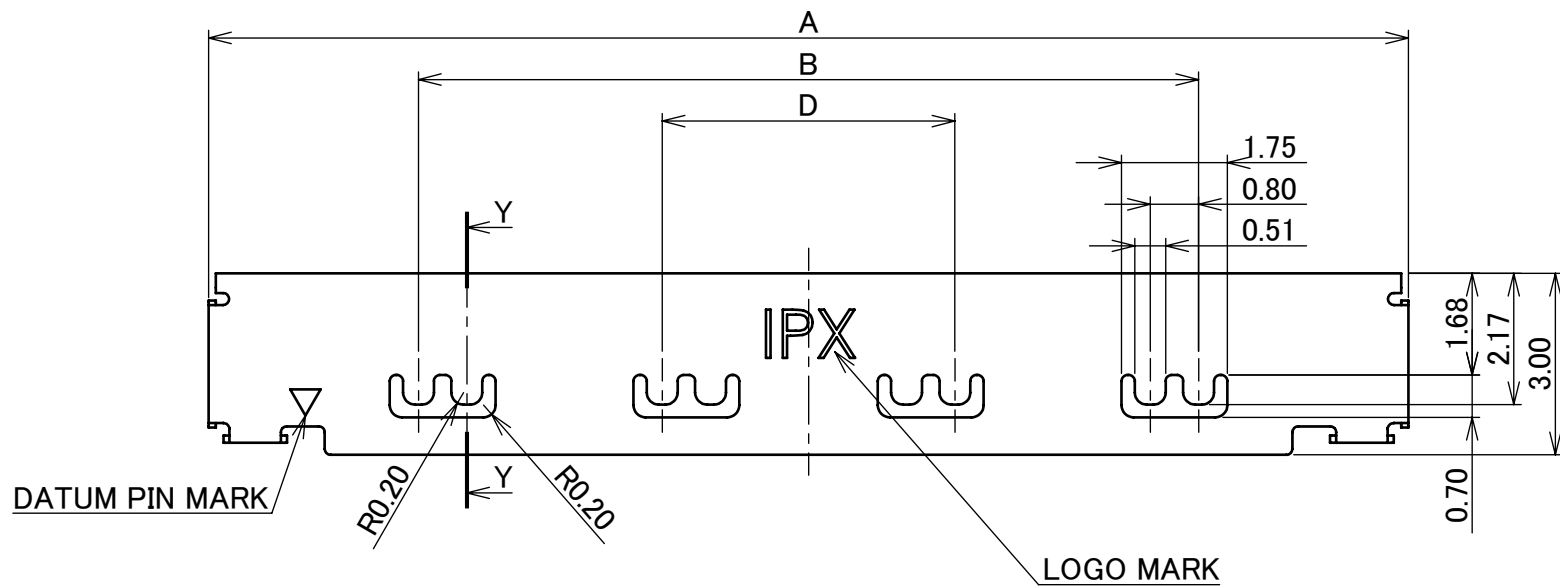
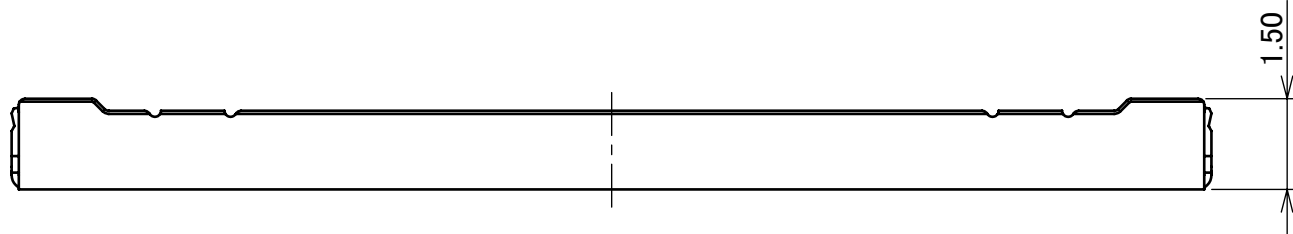
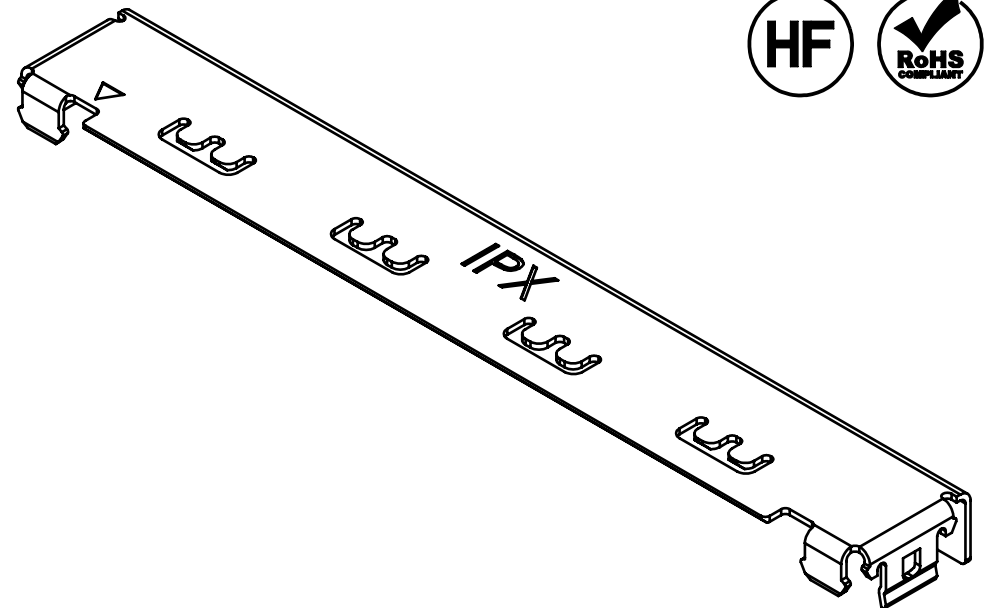

WITH CAREER
(S=2/1)

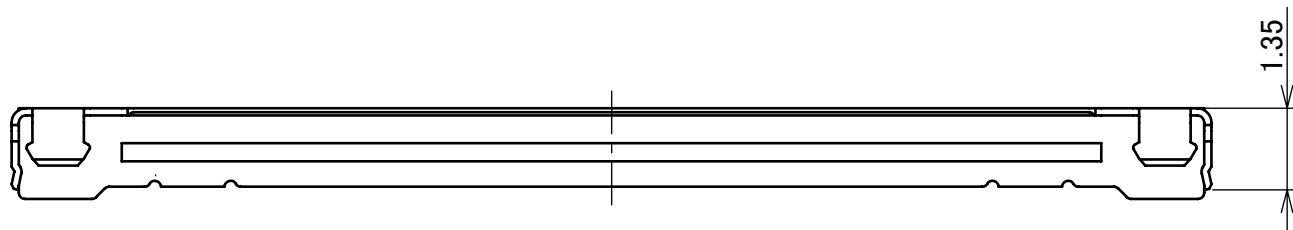

NO.	DISCRIPTION	MATERIAL	FINISH , REMARKS
1	METAL COVER	PHOSPHOR BRONZE	Sn REFLOW 1.00 μ m MIN.

ANGLE	±2°	6 OVER 30 MAX.	±0.3	PROJECTION ⊕	SERIES No. R3	CUSTOMER COPY		
6 MAX.	±0.2	30 OVER 120 MAX.	±0.5					
GENERAL TOLERANCE.				TITLE CABLINÉ® -SS METAL COVER	SCALE 5:1	UNIT mm		
DWG.	DATE							
CHK.								
APP.								
				DWG. No.	2182	SIZE A3	SHEET 2/3	REV. 19

PART NO.	C	E	REEL QTY.	QTY. (1 REEL)	QTY. IN PACKING CARTON (1 CARTON)	PACKING STANDARD
2182-010-03	24.50	40.00	3 REELS	4000	4000 × 3 = 12000	300-348
2182-014-03						
2182-020-03						
2182-030-03	28.50					
2182-032-03	29.30					
2182-035-03	30.50					
2182-040-04	32.50					
2182-050-04	36.50					

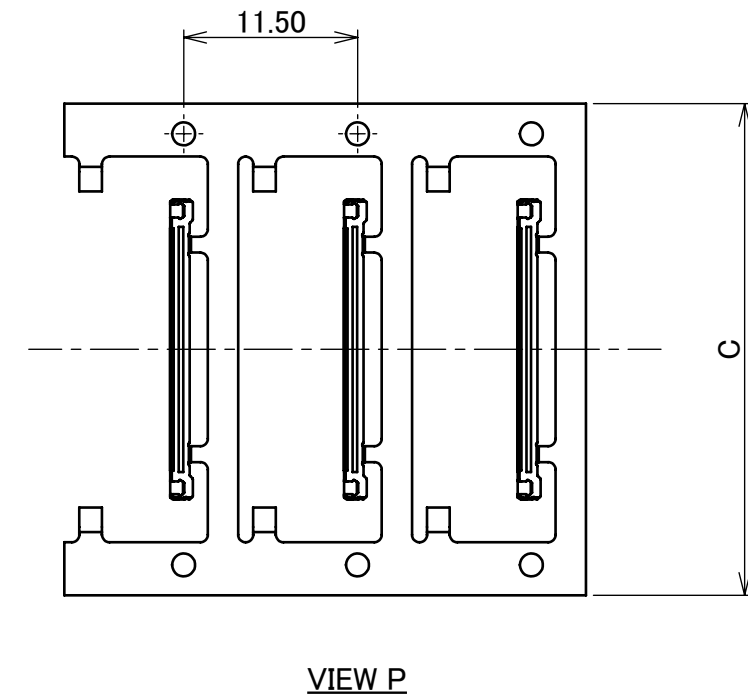
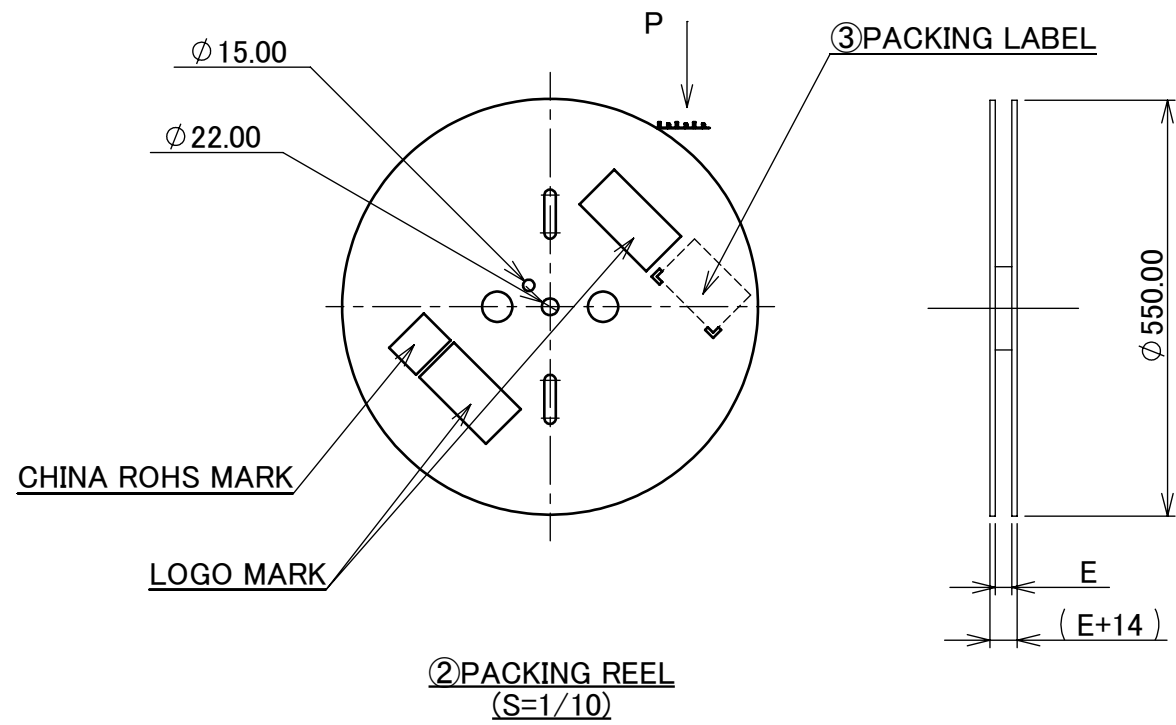

NO.	DISCRIPTION	MATERIAL	FINISH , REMARKS
3	PACKING LABEL	-	-
2	PACKING REEL	CARDBOARD	-

ANGLE	±2°	6 OVER 30 MAX.	±0.3	PROJECTION	SERIES No.	CUSTOMER COPY		
6 MAX.	±0.2	30 OVER 120 MAX.	±0.5		R3	I-PEX SCALE 2:1 UNIT mm SIZE A3 SHEET 3/3 REV. 19		
GENERAL TOLERANCE.				TITLE				
DWG.	DATE			CABLINER [®] -SS METAL COVER				
CHK.								
APP.				DWG. No.	2182			