

Recommended P/N 20976-040E-01

PART NO.	Pos.
20976-040E-01	40

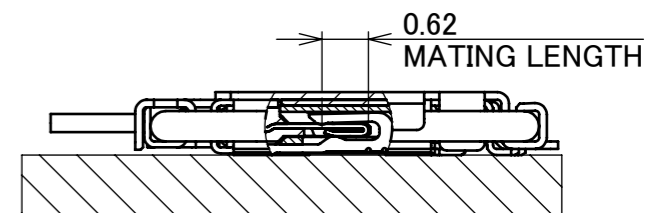

4	SHELL	PHOSPHOR BRONZE	PARTIAL Au 0.03 μm MIN. OVER Ni 1.00 μm MIN.
3	CONTACT B	CORSON ALLOY	CONTACT AREA : Au 0.10 μm MIN. OVER Ni 1.00 μm MIN. SOLDERING AREA : Au 0.03 μm MIN. OVER Ni 1.00 μm MIN.
2	CONTACT A	CORSON ALLOY	CONTACT AREA : Au 0.10 μm MIN. OVER Ni 1.00 μm MIN. SOLDERING AREA : Au 0.03 μm MIN. OVER Ni 1.00 μm MIN.
1	HOUSING	LCP	UL94V-0, BLACK
NO.	DISCRIPTION	MATERIAL	FINISH , REMARKS

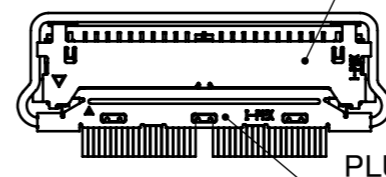
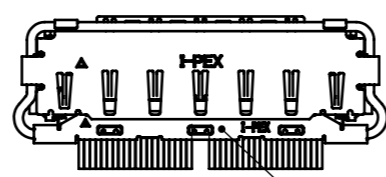
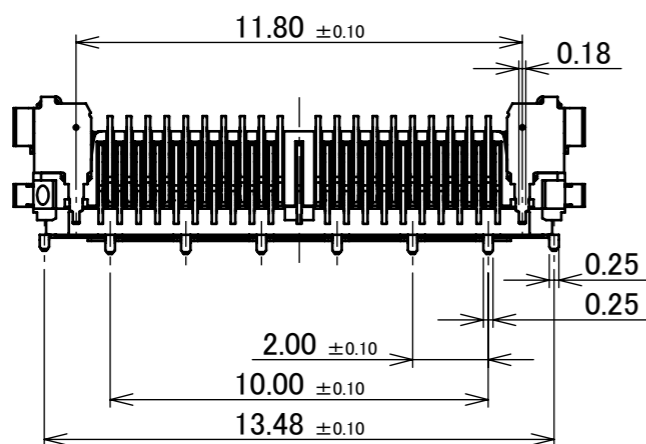
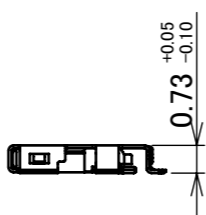
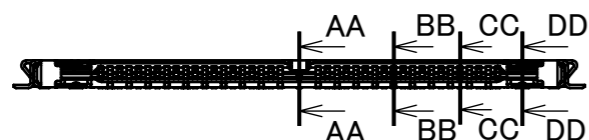
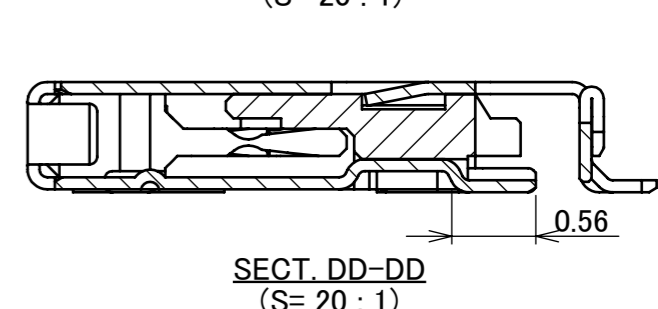
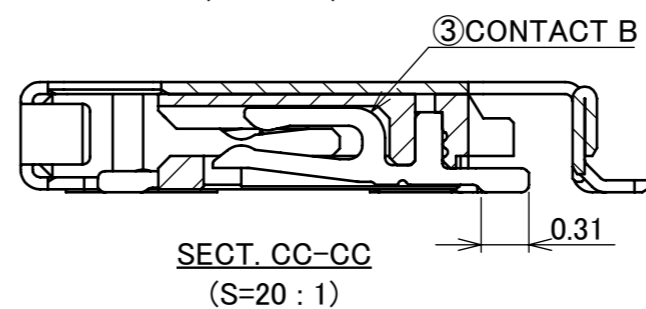
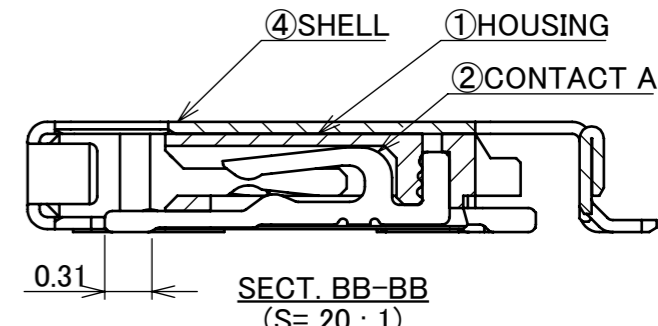
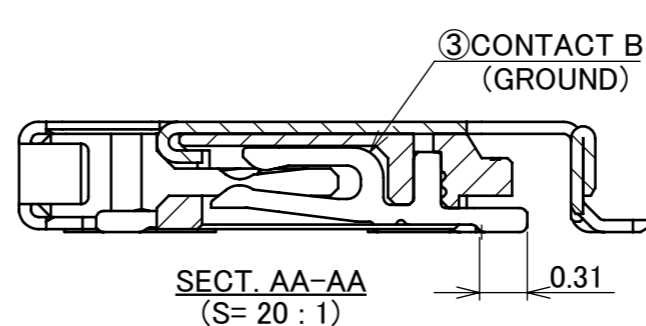
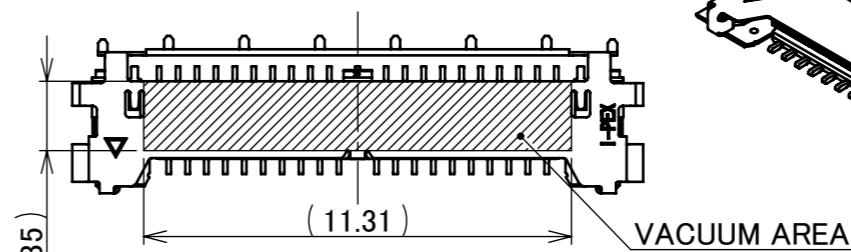
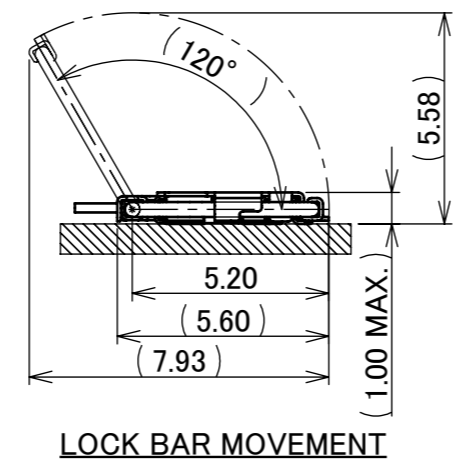
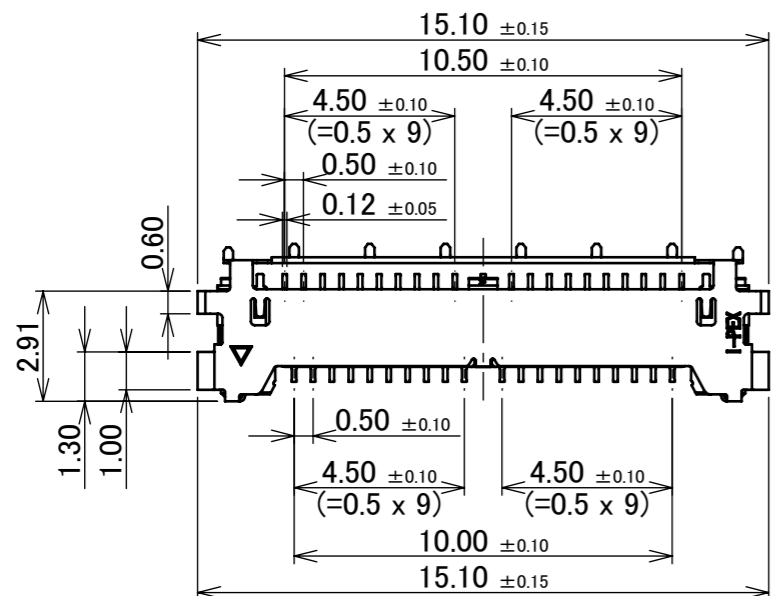
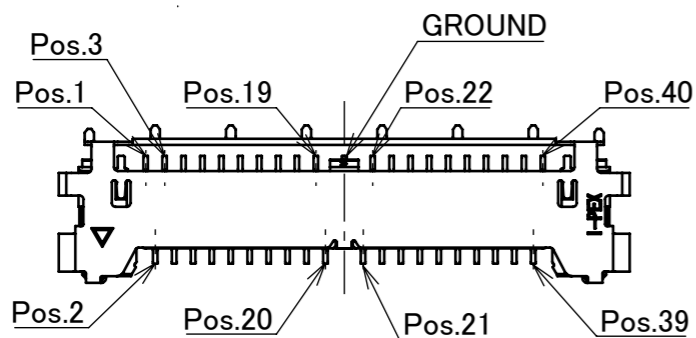

CONTACT ARRANGEMENT

					ANGLE	±2°	6 OVER 30 MAX.	±0.3	PROJECTION ⊕	SERIES No. R1	CUSTOMER COPY			
						6 MAX.	±0.2	30 OVER 120 MAX.						±0.5
					GENERAL TOLERANCE.					TITLE CABLIN® CX II RECEPTACLE ASSEMBLY	SCALE	I-PEX		
2	Z240027	R.H	2024/01/10	H.I	DWG.	DATE			5:1					
1	Z200041	S.Y	2020/06/17	H.I	S.Yamaguchi 2019/08/08						UNIT			
0	Z191044	S.Y	2019/08/08		CHK.	T.Kurachi					mm			
REV.	ECN	BY	DATE	APP.	APP.	Y.Shimada					SIZE	SHEET	REV.	
REVISION RECORD										DWG. No.	20976	A3	1/5	2

ITEMS	SPECIFICATION
APPLICABLE CABLE	MICRO-COAXIAL CABLE : AWG# 46,44 DISCRETE WIRE : AWG# 39
RATING VOLTAGE	100V AC (PER CONTACT PIN)
RATING AMPERAGE (FOR CONTACT)	0.10A AC/DC [AWG#46] PER CONTACT PIN/UP TO 40 CONTACTS 0.15A AC/DC [AWG#44] PER CONTACT PIN/UP TO 40 CONTACTS 0.50A AC/DC [AWG#39] PLUG WITH COVER CABLE ASS'Y (P/N : 20977-040T-01) PER CONTACT PIN/UP TO 8 CONTACTS PLUG WITHOUT COVER CABLE ASS'Y (P/N : 20978-040T-01) PER CONTACT PIN/UP TO 7 CONTACTS ※TESTING BY A REAL MACHINE IS RECOMMENDED BECAUSE TEMPERATURE RISE MAY AFFECTED BY ACTUAL SITUATION
OPERATING TEMPERATURE	233~358K(-40°C~+85°C) (CONTAINING TEMPERATURE RISE BY CURRENT)
OPERATING HUMIDITY	85% MAX.(NON-CONDENSING)
CONTACT RESISTANCE	INITIAL : 388mohm MAX.(AWG#39) / AFTER TEST : \triangle 40mohm MAX. INITIAL : 1,080mohm MAX.(AWG#44) INITIAL : 1,830mohm MAX.(AWG#46)
GROUND SHELL RESISTANCE	INITIAL : 50mohm MAX. / AFTER TEST : \triangle 40mohm MAX.
INSULATION RESISTANCE	INITIAL : 1,000Mohm MIN. / AFTER TEST : 500Mohm MIN.
DIELECTRIC WITHSTANDING VOLTAGE	AC250V 1min
DURABILITY	20 CYCLES
MATING FORCE (INITIAL / 20 CYCLES)	40P : 30.0N MAX.
UNMATING FORCE (INITIAL / 20 CYCLES)	40P : 4.0N MIN.
CABLE RETENTION FORCE	40P : 19.60N MIN.
COPLANARITY	0.10 MAX.
PRODUCT SPECIFICATION	PRS-2403
TEST REPORT	TR-17063
PACKING STANDARD	PST-17126
INSTRUCTION MANUAL	HIM-17035 (WHEN PLUG WITH COVER CABLE ASS'Y IS USED) HIM-17040 (WHEN PLUG WITHOUT COVER CABLE ASS'Y IS USED)
APPEARANCE CRITERIA No.	QLS-A***

ANGLE	$\pm 2^\circ$	6 OVER 30 MAX.	± 0.3	PROJECTION 	SERIES No. R1	CUSTOMER COPY		
	6 MAX.	± 0.2	30 OVER 120 MAX.			± 0.5		
GENERAL TOLERANCE.				TITLE CABLIN [®] CX II RECEPTACLE ASSEMBLY	SCALE 5:1 UNIT mm	I-PEX		
DWG.	DATE							
CHK.								
APP.								
				DWG. No.	20976	SIZE A3	SHEET 2/5	REV. 2

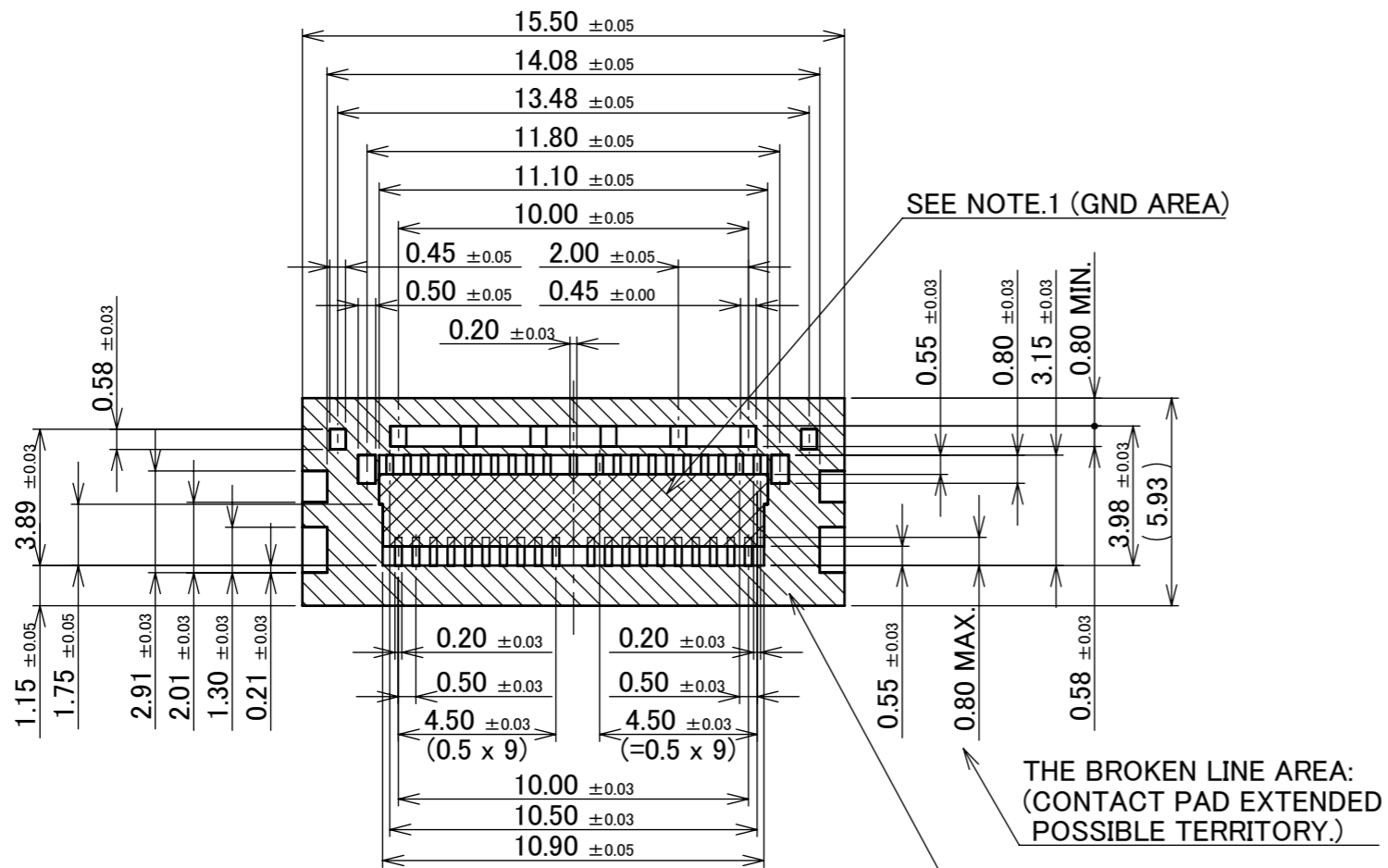

RECOMMENDED FOOTPRINT PATTERN LAYOUT

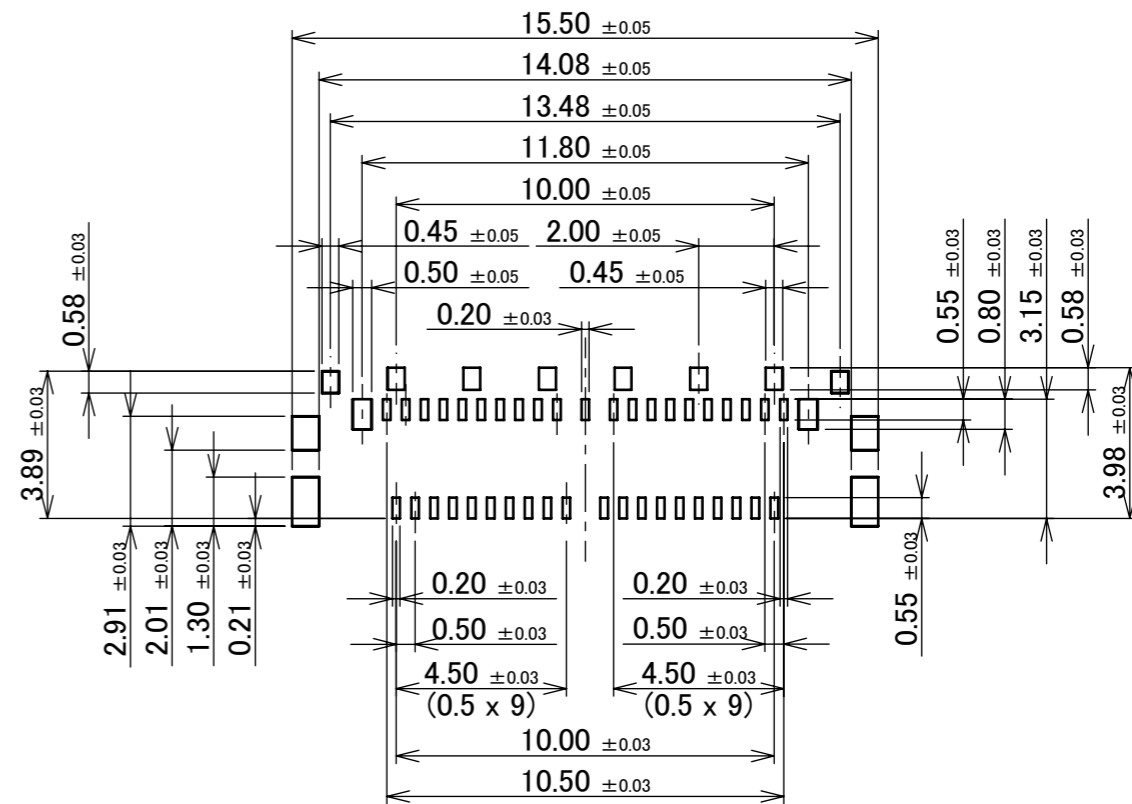

RECOMMENDED METAL MASK LAYOUT
METAL MASK THICKNESS : t=0.12 mm

NOTES.
1. SOLDER RESIST MUST BE APPLIED TO THIS AREA
2. DO NOT MOUNT ANOTHER COMPONENTS IN THIS AREA.

ANGLE	±2°	6 OVER 30 MAX.	±0.3	PROJECTION ⊕	SERIES No. R1	CUSTOMER COPY		
6 MAX.	±0.2	30 OVER 120 MAX.	±0.5					
GENERAL TOLERANCE.				TITLE CABLIN [®] CX II RECEPTACLE ASSEMBLY	SCALE 5:1 UNIT mm	I-PEX		
DWG.	DATE							
CHK.								
APP.								
				DWG. No.	20976	SIZE A3	SHEET 3/5	REV. 2

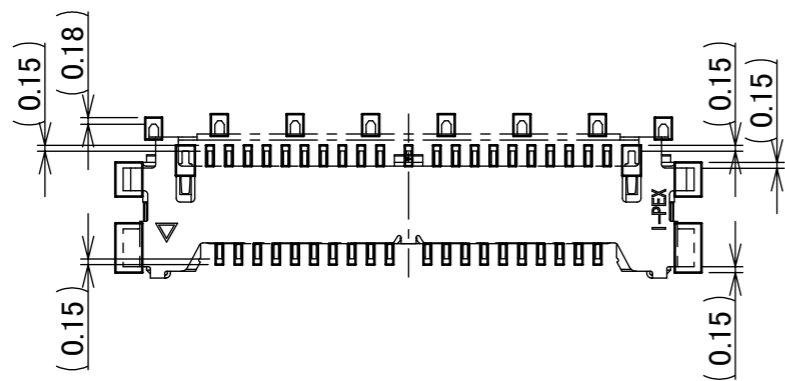

CONNECTOR ON RECOMMENDED FOOTPRINT PATTERN

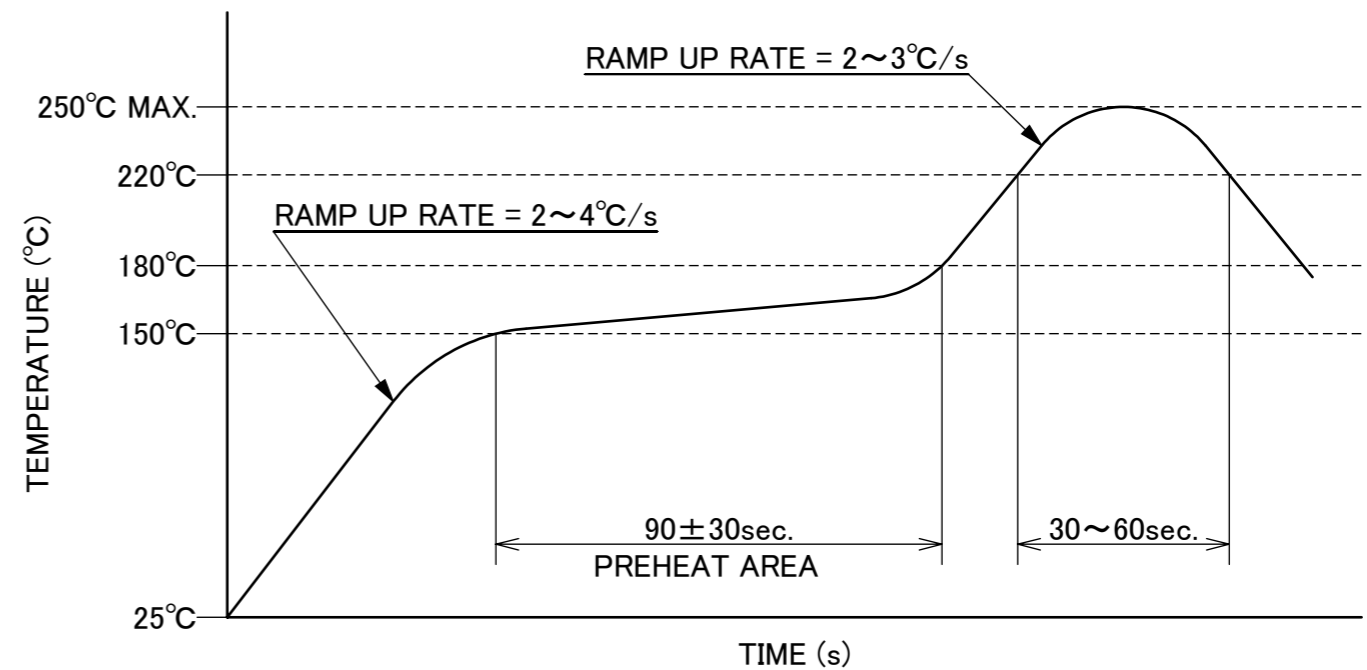

REFLOW TEMPERATURE PROFILE
SENJU METAL INDUSTRY CO., LTD. : M705-SHF(Sn96.5 Ag3.0 Cu0.5)

ANGLE	±2°	6 OVER 30 MAX.	±0.3	PROJECTION ⊕	SERIES No. R1	CUSTOMER COPY			
6 MAX.	±0.2	30 OVER 120 MAX.	±0.5						
GENERAL TOLERANCE.				TITLE		SCALE	I-PEX		
DWG.	DATE			CABLIN [®] -CX II RECEPTACLE ASS'Y		5:1			
CHK.						UNIT			
APP.				DWG. No. 20976		mm			
						SIZE	SHEET	REV.	
						A3	4/5	2	

DEVICE P/N	QTY. PER EMBOSS REEL (PIECES / REEL)	QTY. PER PACKING CARTON (REELS / CARTON)
20976-040E-01	9,000 / REEL	5 / CARTON = 45,000

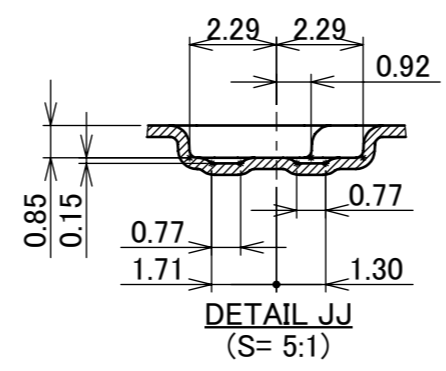
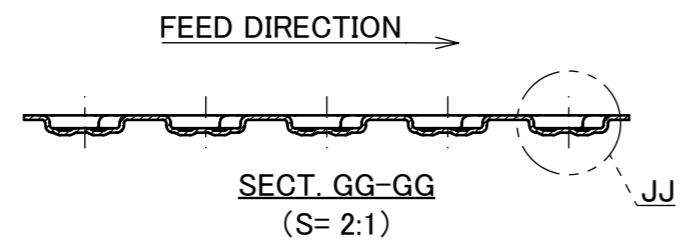
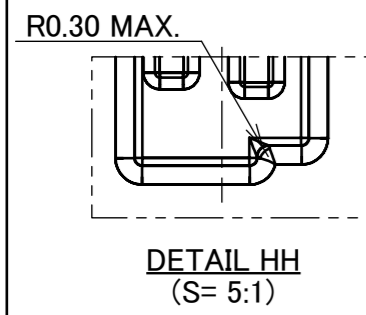
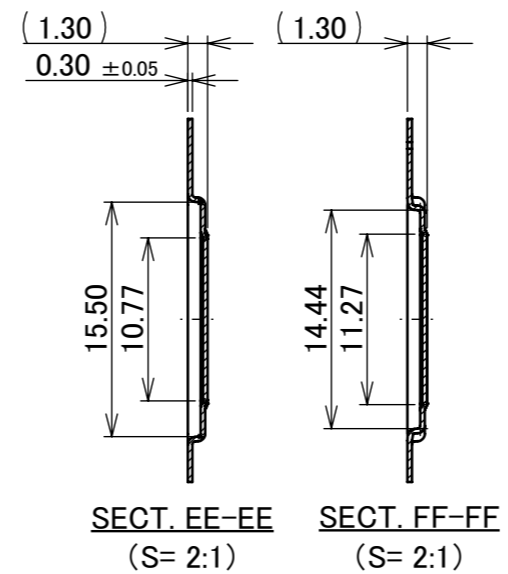
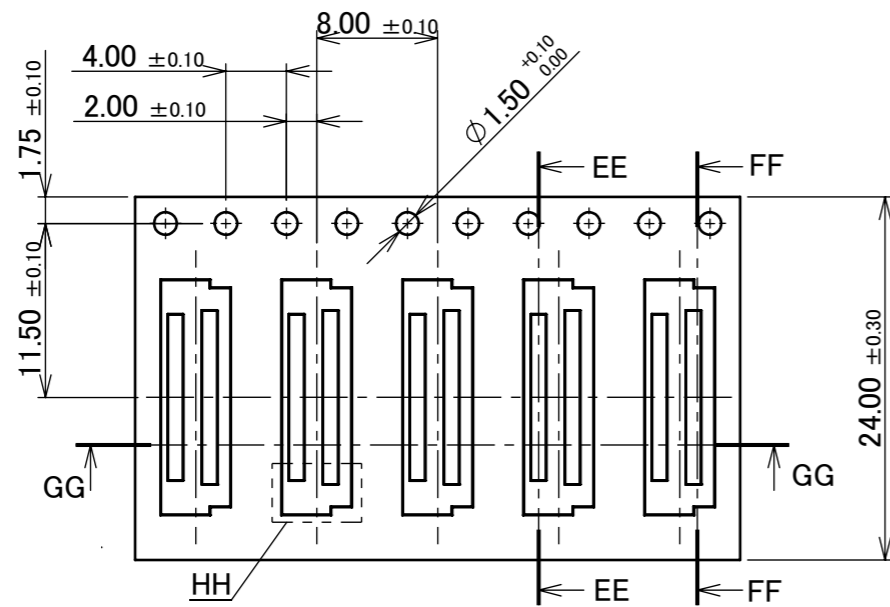
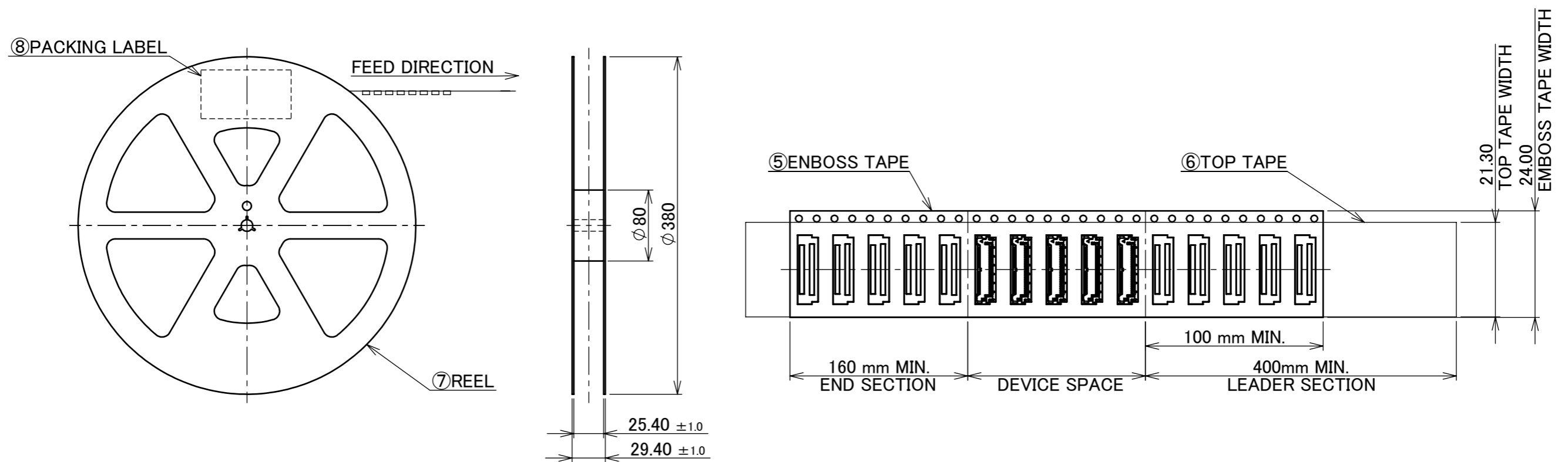

- NOTES.
- TAPING SPECIFICATION FOLLOWS JIS C 0806 (IEC 60286-3).
 - MAKE EMPTY SECTION OF LEADER AND END ON EACH END OF THE TAPE.
 - TOP TAPE SHALL NOT STICK OUT FROM EMBOSS TAPE.
 - TOP TAPE SHALL NOT COVER FEED HOLE.

NO.	DISCRIPTION	MATERIAL	FINISH , REMARKS
8	PACKING LABEL	-	-
7	REEL	PS	-
6	TOP TAPE	PET t=0.062 TRANSPARENCY	ANTI-STATIC TYPE
5	EMBOSS TAPE	PS t=0.3 TRANSPARENCY	ANTI-STATIC TYPE

ANGLE	±2°	6 OVER 30 MAX.	±0.3	PROJECTION ⊕	SERIES No. R1	CUSTOMER COPY	
6 MAX.	±0.2	30 OVER 120 MAX.	±0.5				
GENERAL TOLERANCE.				TITLE CABLIN® CX II RECEPTACLE ASSEMBLY	SCALE 5:1 UNIT mm	I-PEX	
DWG.	DATE						
CHK.							
APP.							
DWG. No. 20976				SIZE A3	SHEET 5/5	REV. 2	

Confidential C

I-PEX Inc.

QKE-DFE06-02 REV.12