

Recommended P/N 2618-0\*\*1

PART NO.	POS.	A	B	C
2618-0301	30	16.94	3.60	11.88
2618-0401	40	20.94	5.60	15.88

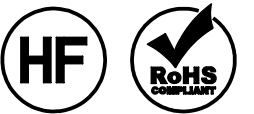

P/N:2618-0\*\*1  
POS.

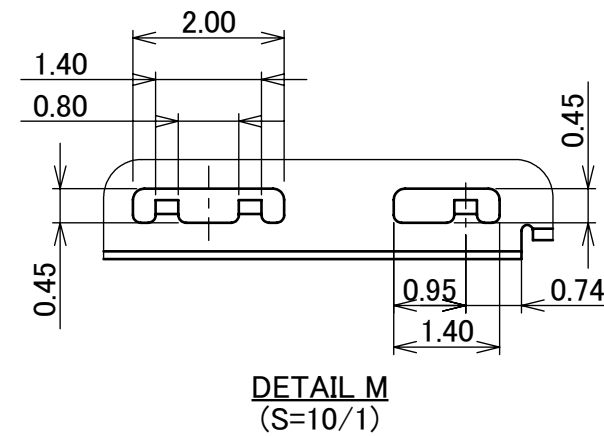
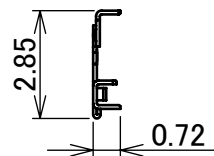
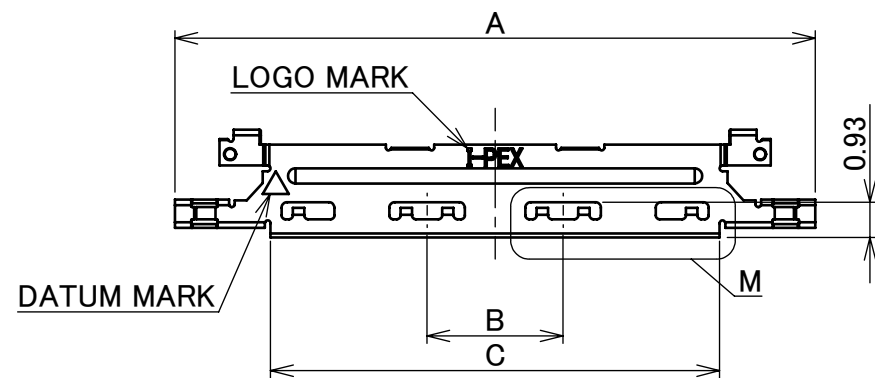
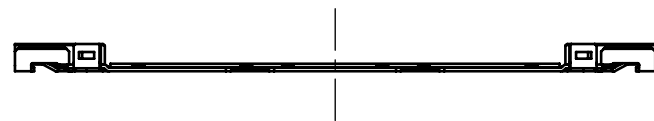
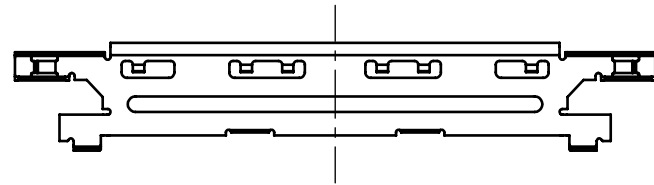
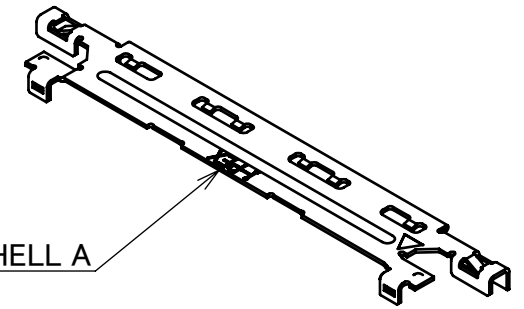

NO.	DISCRIPTION	MATERIAL	FINISH , REMARKS
1	SHELL A	PHOSPHOR BRONZE	Au 0.05 μ m MIN. OVER Ni 1.00 μ m MIN.

REV.	ECN	BY	DATE	APP.	APP.	DATE	DWG. No.	SIZE	SHEET	REV.
5	Z191178	Y.Sasa	Sept./06/'19	H.I	ANGLE	±2°	6 OVER 30 MAX.	±0.3		
4	Z180949	M.N	July/20/'18	Y.S	6 MAX.	±0.2	30 OVER 120 MAX.	±0.5		
3	Z170312	R.H	Mar./23/'17	M.T	GENERAL TOLERANCE.					
2	Z12056	Y.W	Jan./24/'12	E.K	DWG.		DATE			
1	Z08242	N.H	May/28/'08	E.K	N.Hamauchi		Feb./28/'08			
0	Z08094	N.H	Feb./28/'08		CHK.		DATE			
					E.Kawabe		Feb./28/'08			

PROJECTION

SERIES No. R0

CUSTOMER COPY

TITLE CABLINE®-CBL PLUG SHELL A

SCALE 5:1

UNIT mm

I-PEX

DWG. No. 2618

SIZE A3 SHEET 1/2 REV. 5

PART NO.	POS.	D	E	REEL QTY.	QTY. (1 REEL)	QTY. IN PACKING CARTON (1 CARTON)	PACKING STANDARD
2618-0301	30	28.00	30.00	3	6000	6000 × 3 = 18000	300-655
2618-0401	40	32.00	35.00				

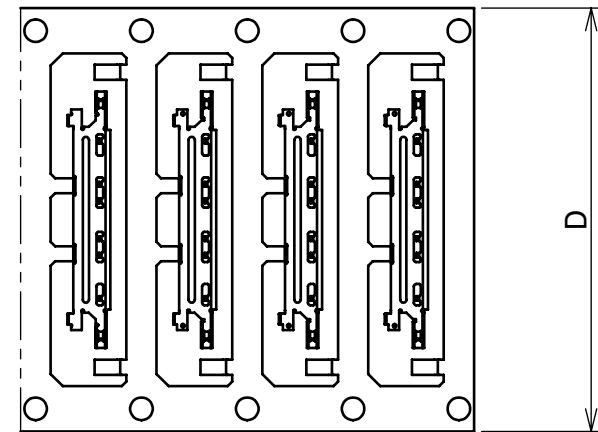
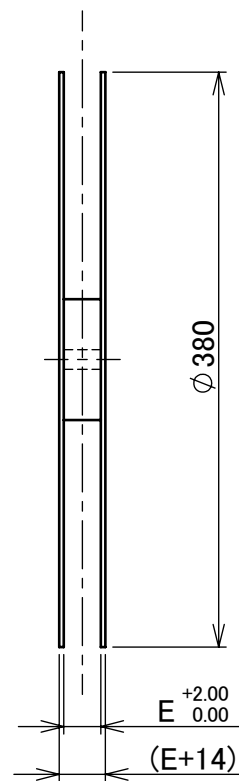
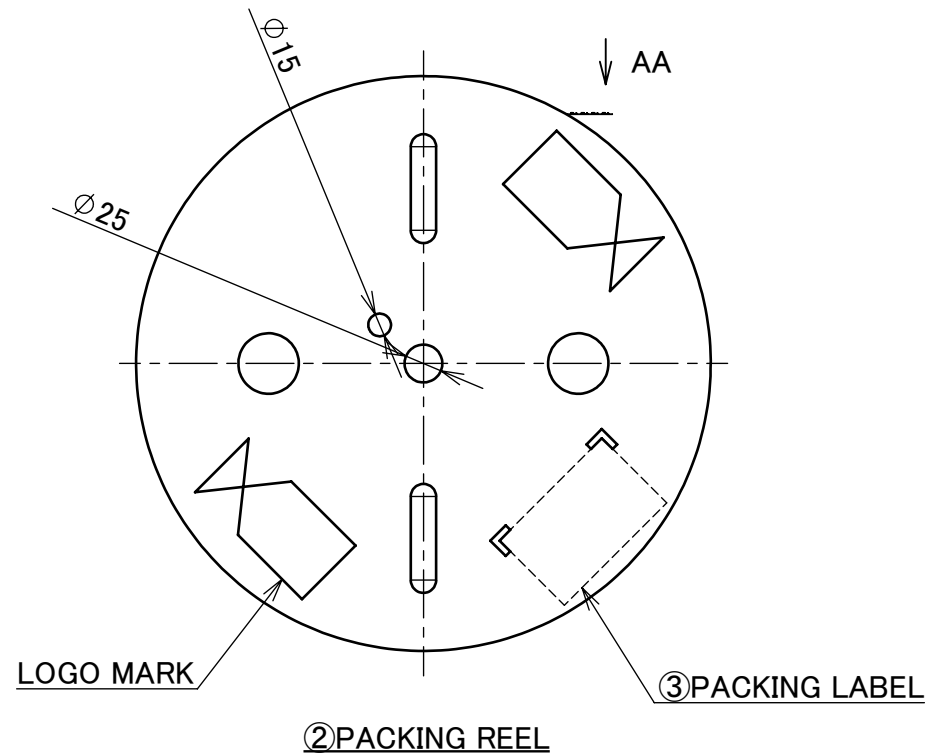

VIEW AA

3	PACKING LABEL	-	-
2	PACKING REEL	CARDBOARD	-
NO.	DISCRIPTION	MATERIAL	FINISH , REMARKS

ANGLE	±2°	6 OVER 30 MAX.	±0.3	PROJECTION ⊕	SERIES No. R0	CUSTOMER COPY
	6 MAX.	±0.2	30 OVER 120 MAX.			
GENERAL TOLERANCE.				TITLE CABLIN <sup>®</sup> -CBL PLUG SHELL A	DWG. No. 2618	SCALE 2:1
DWG.	DATE		UNIT mm			I-PEX
CHK.	DATE		SIZE A3			
APP.	DATE		SHEET 2/2 REV. 5			