

Recommended P/N 2619-0**0

PART NO.	POS.	A	B
2619-0300	30	18.44	13.00
2619-0400	40	22.44	17.00

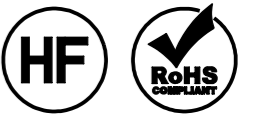

2619-0**0
POS.

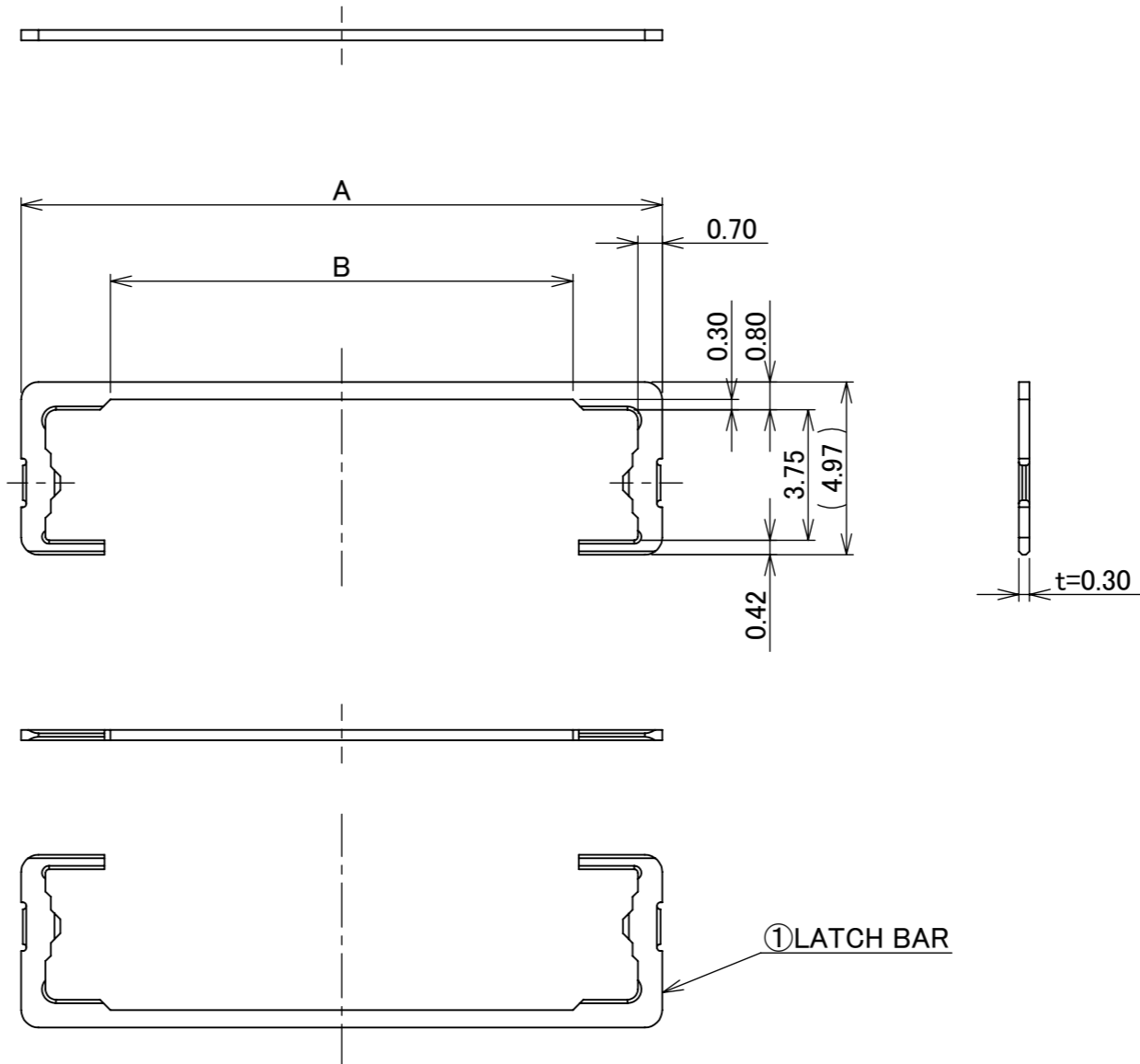

NO.	DISCRIPTION	MATERIAL	FINISH , REMARKS
1	LATCH BAR	SUS	-

REV.	ECN	BY	DATE	APP.	APP.	DWG. No.	2619	SIZE	SHEET	REV.
7	Z210547	R.M	May/26/'21	H.I	ANGLE	±2°	6 OVER 30 MAX.	±0.3	PROJECTION SERIES No. R1	CUSTOMER COPY
6	Z191178	Y.Sasa	Sept./06/'19	H.I	6 MAX.	±0.2	30 OVER 120 MAX.	±0.5		
5	Z180949	M.N	July/20/'18	Y.S	GENERAL TOLERANCE.			TITLE CABLINÉ® -CBL PLUG LATCH BAR	SCALE	I-PEX
4	Z13176	T.S	Mar./04/'13	Tom	DWG.	DATE	2008/02/28		5:1	
3	Z12056	Y.W	Jan./24/'12	E.K	N.Hamauchi				UNIT	
2	Z11139	T.S	Apr./07/'11	E.K	CHK.				mm	
REVISION RECORD					E.Kawabe	DWG. No.	2619	A3	1/2	7

PART NO.	POS.	C	D	REEL QTY.	QTY. (1 REEL)	QTY. IN PACKING CARTON (1 CARTON)	PACKING STANDARD
2619-0300	30	30.00	26.40	2	30000	30000 × 2 = 60000	300-656
2619-0400	40	35.00	30.40				

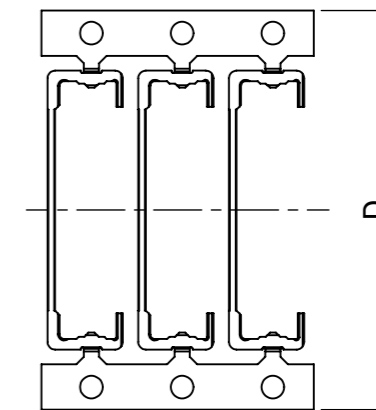
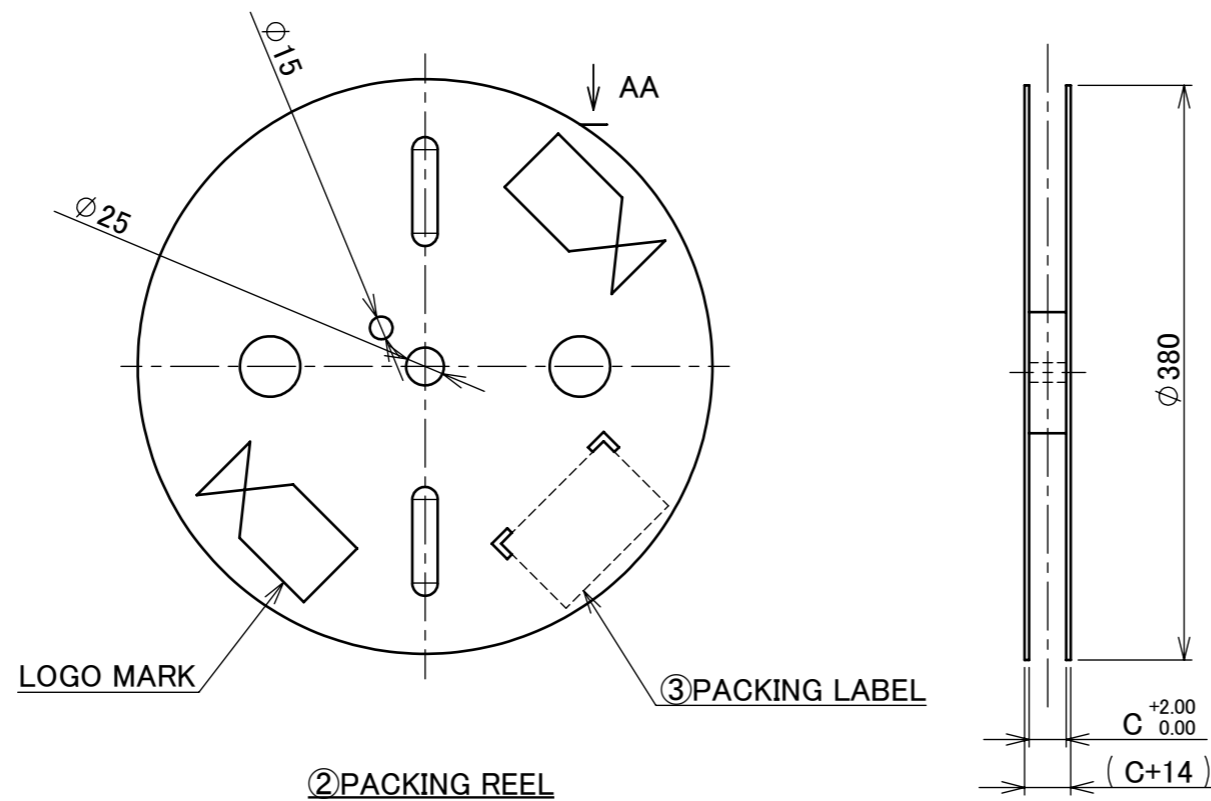

VIEW AA

3	PACKING LABEL	-	-
2	PACKING REEL	CARDBOARD	-
NO.	DISCRIPTION	MATERIAL	FINISH , REMARKS

ANGLE	±2°	6 OVER 30 MAX.	±0.3	PROJECTION ⊕	SERIES No. R1	CUSTOMER COPY					
6 MAX.	±0.2	30 OVER 120 MAX.	±0.5								
GENERAL TOLERANCE.				TITLE CABLIN [®] -CBL PLUG LATCH BAR		SCALE 2:1	I-PEX				
DWG.	DATE			DWG. No. 2619		UNIT mm					
CHK.						SIZE A3				SHEET 2/2	REV. 7
APP.											