

Recommended P/N 20473-0**T-10

PART NO.	POS.	A	B	C	D	E	F	G	H	J
20473-030T-10	30	11.60	12.40	12.65	15.08	12.65	16.94	15.34	9.00	11.88
20473-040T-10	40	15.60	16.40	16.65	19.08	16.65	20.94	19.34	13.00	15.88

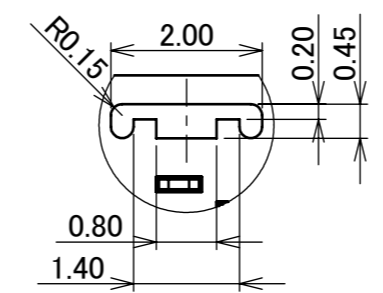

DETAIL AA (S=10/1)

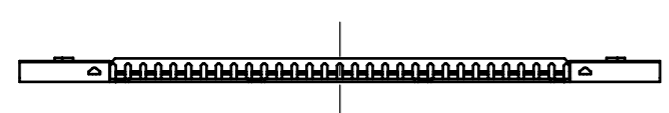
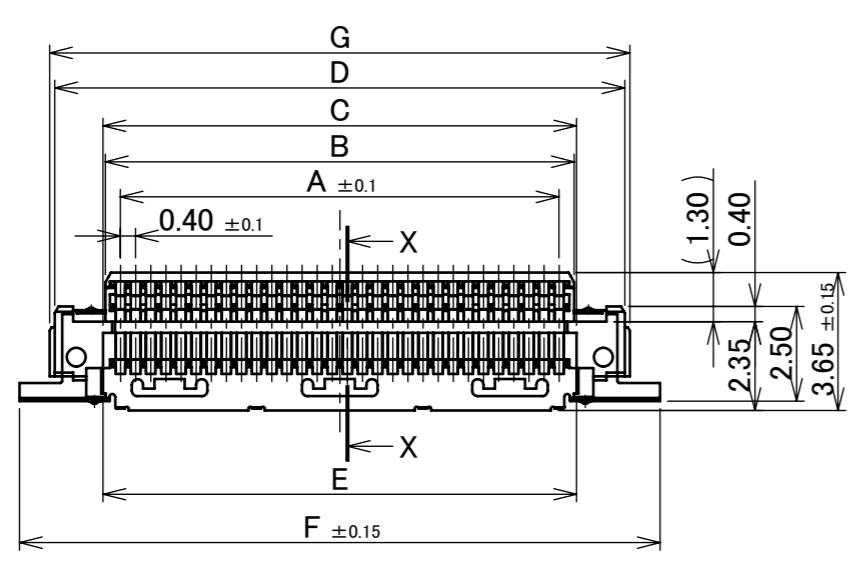
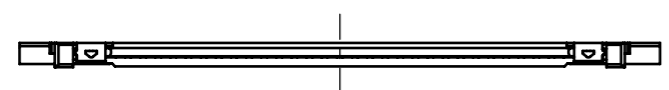
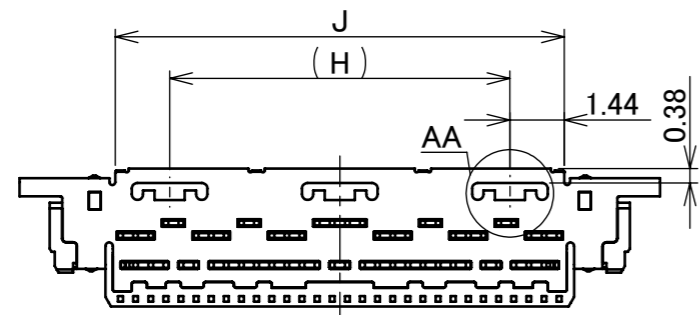
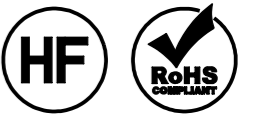
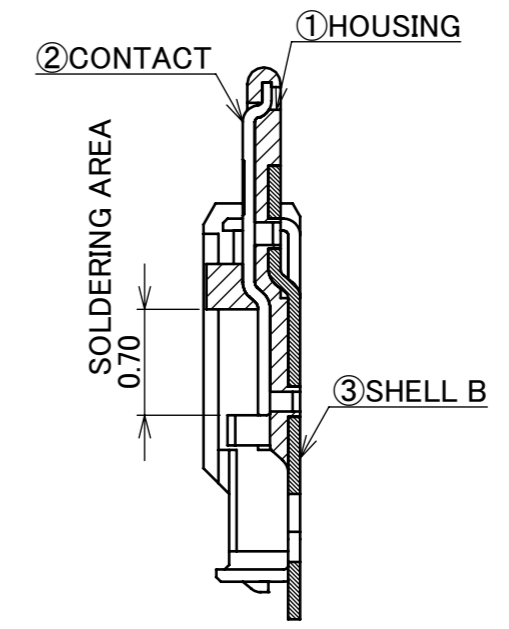
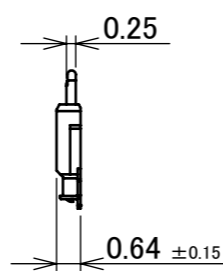

SECT. X-X (S=10/1)

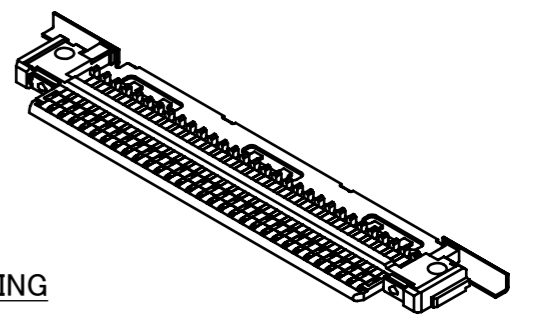

NOTES
 1. THIS PART IS ASSEMBLED WITH SHELL A(P/N 2618-0**1) AND LATCH BAR(P/N 2619-#**0) AFTER SOLDERED THE CABLE, AND IT BECOMES P/N 20472-0**T-10

NO.	DISCRIPTION	MATERIAL	FINISH , REMARKS
3	SHELL B	PHOSPHOR BRONZE	Au 0.05 μ m MIN. OVER Ni 1.00 μ m MIN.
2	CONTACT	PHOSPHOR BRONZE	Au 0.1 μ m MIN. OVER Ni 1.00 μ m MIN.
1	HOUSING	LCP	UL94V-0, BLACK

REV.	ECN	BY	DATE	APP.	APP.	DATE	DWG. No.	SIZE	SHEET	REV.	
6	Z211210	R.M	Oct./04/'21	H.I	ANGLE	±2°	6 OVER 30 MAX.	±0.3			
5	Z191178	Y.Sasa	Sept./06/'19	H.I	6 MAX.	±0.2	30 OVER 120 MAX.	±0.5			
4	Z180949	M.N	July/20/'18	Y.S	GENERAL TOLERANCE.						
3	Z160058	K.H	Jan./21/'16	N.K	DWG.		DATE				
2	Z12056	Y.W	Jan./24/'12	E.K	N.Hamauchi		2008/02/28				
1	Z08190	N.H	Apr./19/'08	E.K	CHK.						
REVISION RECORD					APP.	E.Kawabe	2008/02/28	20473	A3	1/2	6

PART NO.	QTY. IN DITCH (PIECES / DITCH)	QTY. IN TRAY (PIECES / TRAY)	QTY. PER SHIPPING CARTON (TRAYS / CARTON)	QTY. PER PACKING CARTON (TRAYS / CARTON)	PACKING STANDARD
20473-030T-10	1	100	20 / CARTON = 2000	8000 (4BOXES)	300-654
20473-040T-10					

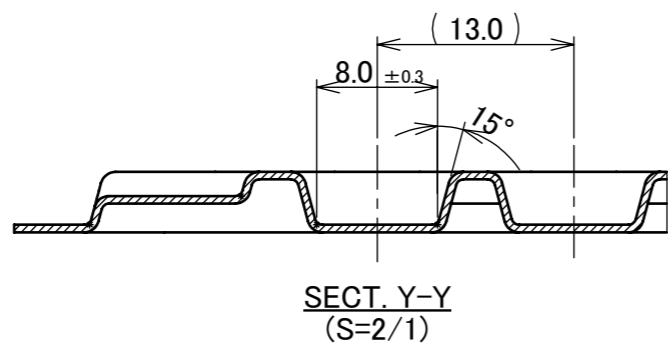
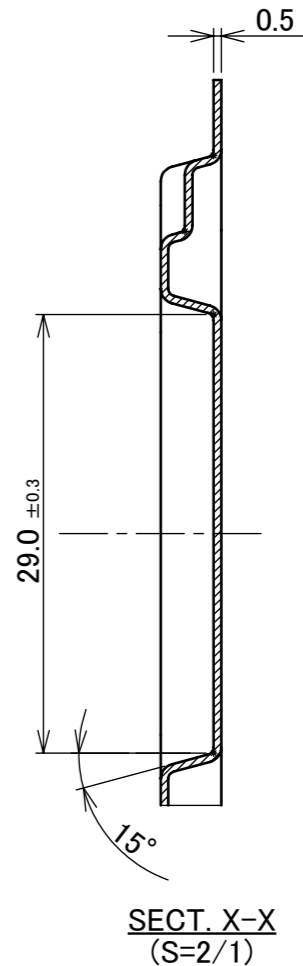
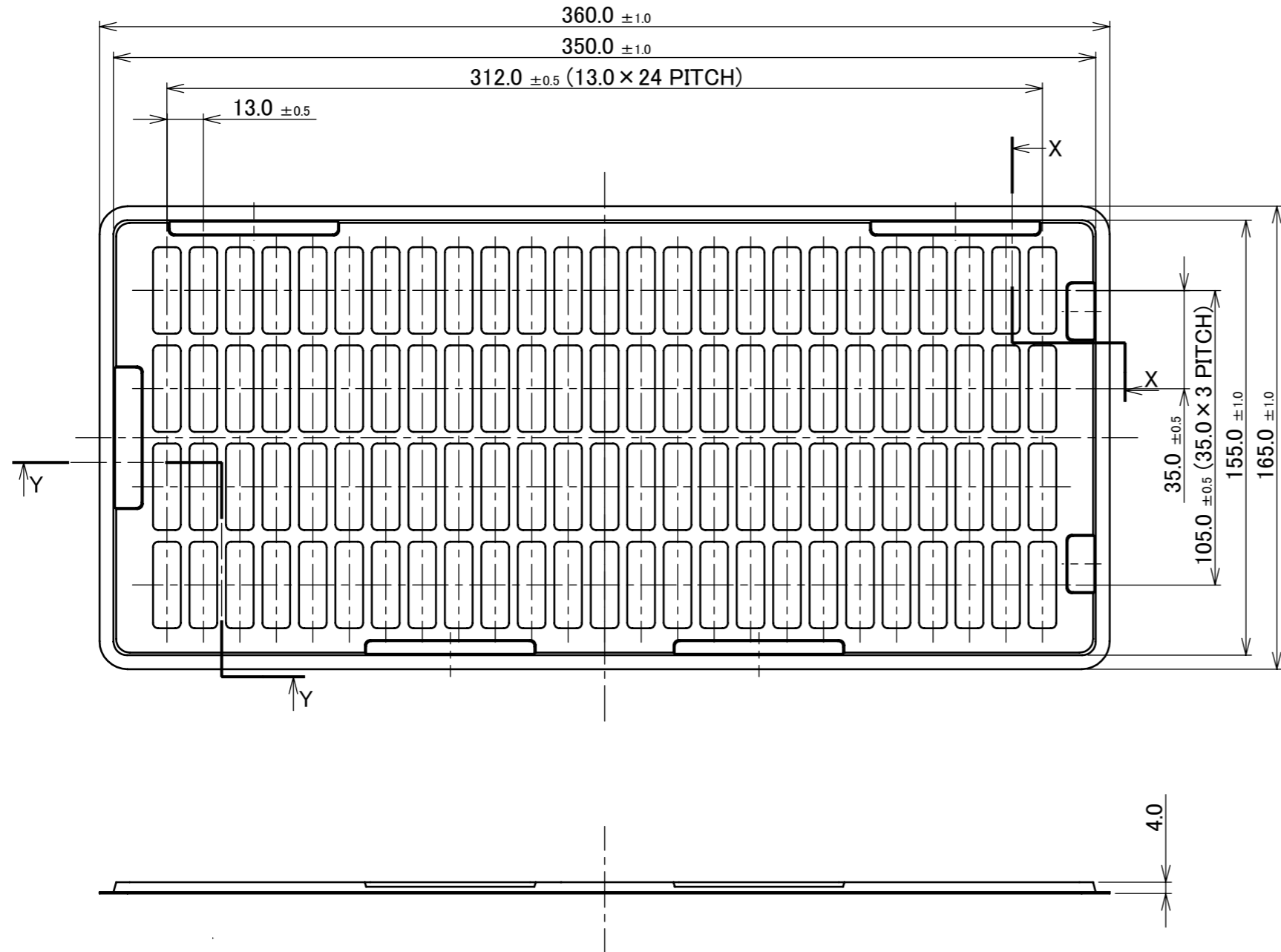

4	TRAY	PP	ANTI-STATIC TYPE
NO.	DISCRIPTION	MATERIAL	FINISH , REMARKS

ANGLE	±2°	6 OVER 30 MAX.	±0.3	PROJECTION ⊕	SERIES No. R3	CUSTOMER COPY	
6 MAX.	±0.2	30 OVER 120 MAX.	±0.5				
GENERAL TOLERANCE.				TITLE CABLIN [®] -CBL PLUG HOUSING ASS'Y		SCALE 1:2	I-PEX
DWG.	DATE			DWG. No. 20473		UNIT mm	
CHK.				SIZE A3	SHEET 2/2	REV. 6	