

Recommended P/N 20525-0\*\*E-02(12~60P) 20525-210E-02(10P)

PART NO.	POS.	A	B	C	D
20525-#10E-02	10	5.40	3.60	8.43	9.20
20525-#12E-02	12	6.20	4.40	9.23	10.00
20525-#20E-02	20	9.40	7.60	12.43	13.20
20525-#30E-02	30	13.40	11.60	16.43	17.20
20525-#40E-02	40	17.40	15.60	20.43	21.20
20525-#50E-02	50	21.40	19.60	24.43	25.20
20525-#60E-02	60	25.40	23.60	28.43	29.20

**PATENT REGISTERED**



P/N : 20525-#\*\*E-02  
 POS. SEE TABLE 1

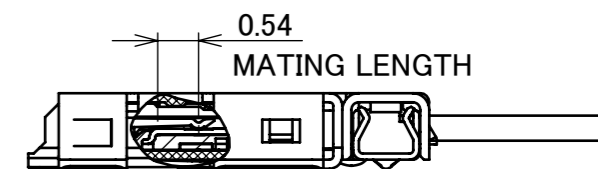

MATING CONDITION

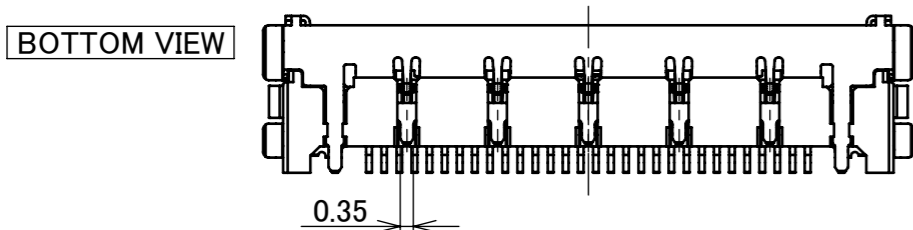
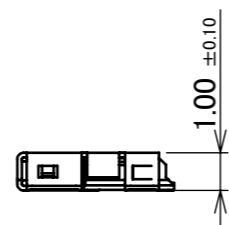
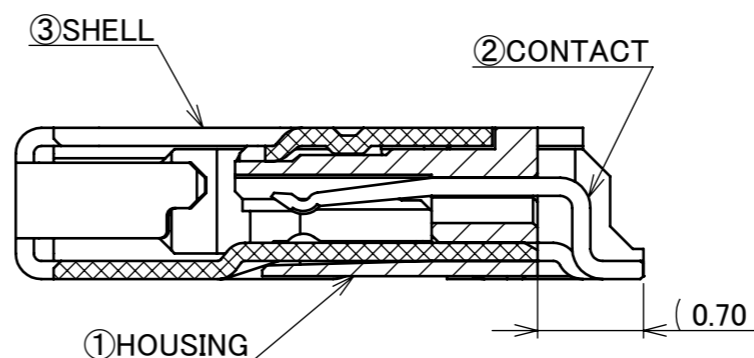
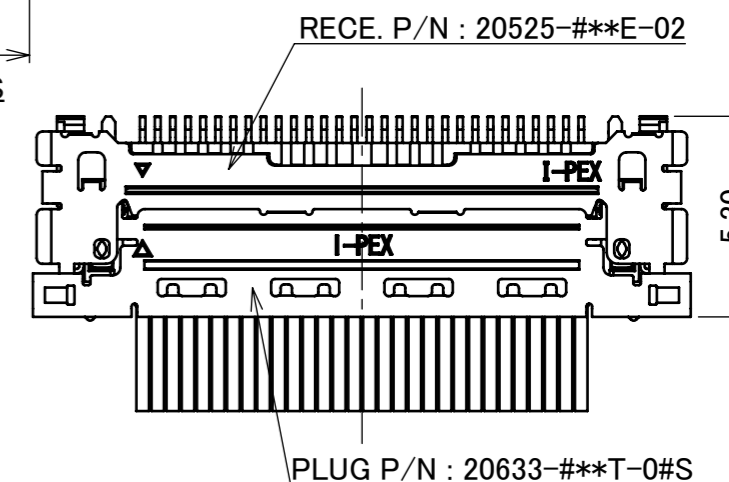
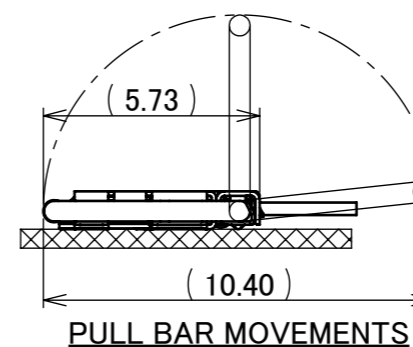
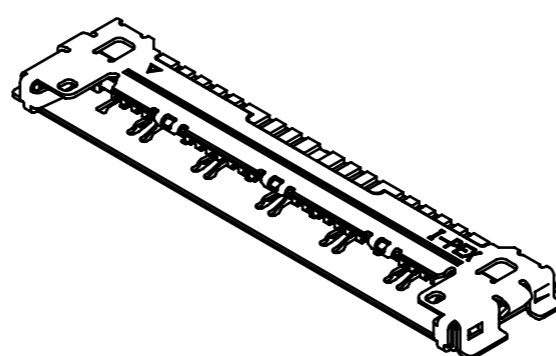
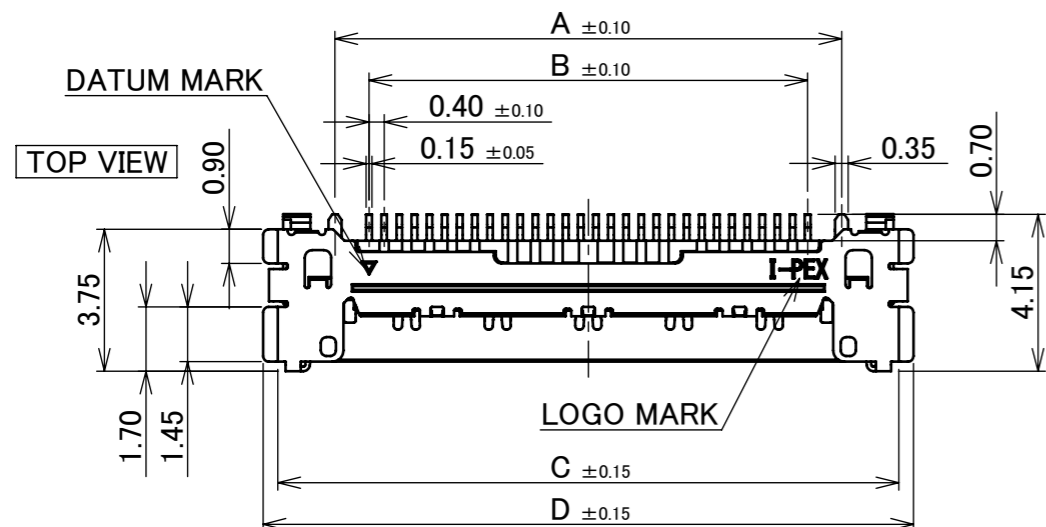

TABLE.1

PART NO.	CONTACT FINISH	SHELL FINISH
20525-0**E-02	CONTACT AREA : Au 0.1 μm MIN. OVER Ni 1.00 μm MIN. SOLDERING AREA : Au 0.03 μm MIN. OVER Ni 1.00 μm MIN.	Au 0.02 μm MIN. OVER Ni 1.00 μm MIN.
20525-2**E-02	CONTACT AREA : Au 0.03 μm MIN. OVER Ni 1.00 μm MIN. SOLDERING AREA : Au 0.03 μm MIN. OVER Ni 1.00 μm MIN.	ALL OVER Ni 1.00 μm MIN. SOLDERING AREA : Au 0.02 μm MIN.

NO.	DISCRIPTION	MATERIAL	FINISH , REMARKS
3	SHELL	PHOSPHOR BRONZE	SEE TABLE 1
2	CONTACT	PHOSPHOR BRONZE	SEE TABLE 1
1	HOUSING	LCP	UL94V-0, BLACK

REV.	ECN	BY	DATE	APP.	APP.	ANGLE	±2°	6 OVER 30 MAX.	±0.3	PROJECTION	SERIES No.	CUSTOMER COPY		
25	Z210833	M.N	July/26/'21	H.I		6 MAX.	±0.2	30 OVER 120 MAX.	±0.5		R7	TITLE <b>CABLINE® -CA</b> <b>RECE. ASSY</b>		
24	Z201150	T.Ono	Nov./05/'20	H.I		GENERAL TOLERANCE.							SCALE	
23	Z200341	Y.Sasa	Mar./24/'20	H.I		DWG.		DATE		5:1				
22	Z200258	Y.Sasa	Mar./05/'20	H.I		T.Kurachi		2009/11/13		UNIT				
21	Z181387	K.Hara	Oct./26/'18	Y.S		CHK.				mm				
20	Z181125	M.N	Aug./29/'18	Y.S		Y.Hashimoto		2009/11/16		SIZE				
REV.	ECN	BY	DATE	APP.	APP.	REVISION RECORD				DWG. No.	20525	SIZE	SHEET	REV.
												A3	1/6	25

PART NO.  
20525-\*\*\*E-02

**BOTTOM VIEW**

**PATENT REGISTERED**

**10P**

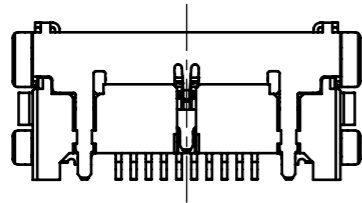

**12P**

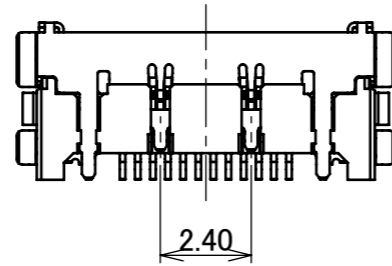

**20P**

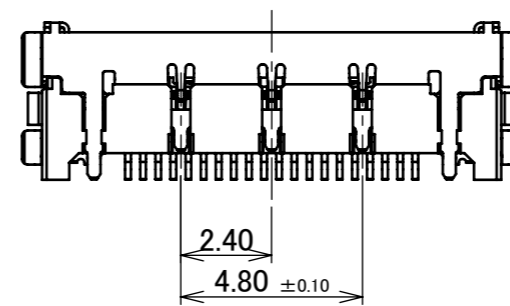

**30P**

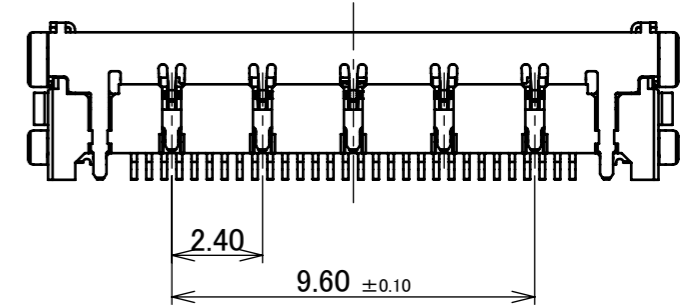

**40P**

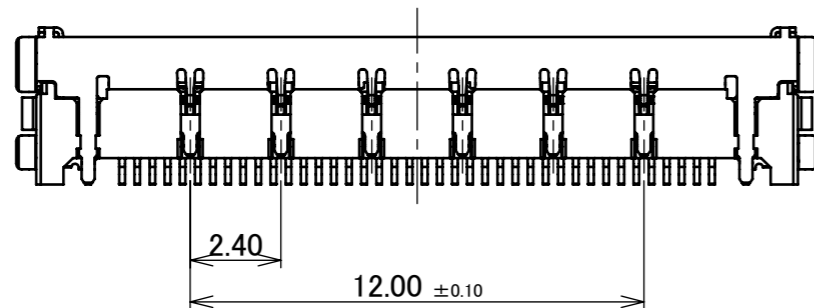

**50P**

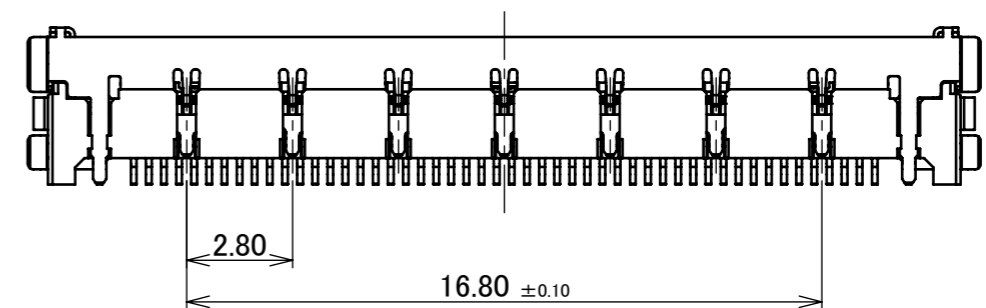

**60P**

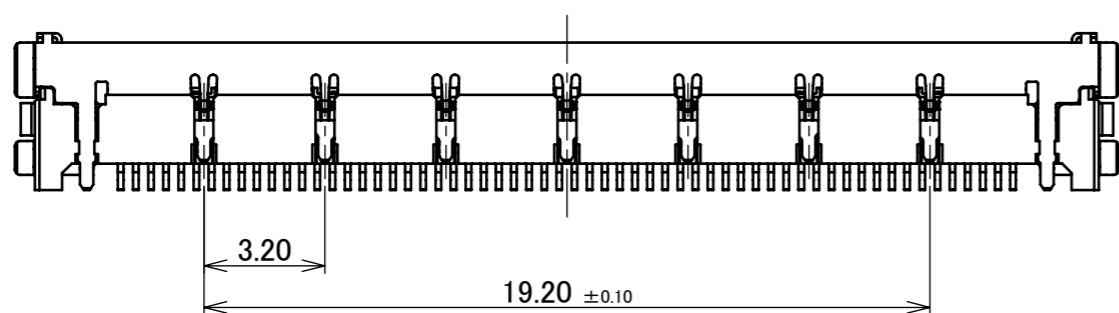

ANGLE	±2°	6 OVER 30 MAX.	±0.3	PROJECTION ⊕	SERIES No. R7	CUSTOMER COPY		
	6 MAX.	±0.2	30 OVER 120 MAX.					±0.5
GENERAL TOLERANCE.				TITLE CABLIN <sup>®</sup> -CA RECE. ASSY		SCALE 5:1	<b>I-PEX</b>	
DWG.	DATE			DWG. No. 20525		UNIT mm		
CHK.						SIZE A3	SHEET 2/6	REV. 25
APP.								

ITEMS	SPECIFICATION
APPLICABLE CABLE	MICRO COAX : AWG# 44 , 42 , 40 , 38 , 36 DISCRETE : AWG# 36, 34 TWINCOAX : AWG# 40
RATING VOLTAGE	100V AC (PER CONTACT)
RATING AMPERAGE (FOR CONTACT)	0.1A AC/DC [AWG#44] PER CONTACT/UP TO 60 CONTACTS 0.24A AC/DC [AWG#42] PER CONTACT/UP TO 50 CONTACTS 0.3A AC/DC [AWG#40] PER CONTACT/UP TO 40 CONTACTS 0.5A AC/DC [AWG#38] PER CONTACT/UP TO 14 CONTACTS 0.8A AC/DC [AWG#36] PER CONTACT/UP TO 6 CONTACTS 1.0A AC/DC [AWG#34] PER CONTACT/UP TO 4 CONTACTS ※TESTING BY A REAL MACHINE IS RECOMMENDED BECAUSE TEMPERATURE RISE MAY AFFECTED BY ACTUAL SITUATION.
OPERATING TEMPERATURE	233~358K (-40°C~85°C)
OPERATING HUMIDITY	85% MAX. (NON-CONDENDING)
CONTACT RESISTANCE	INITIAL : 180mohm MAX. (AWG#34) / AFTER TEST : $\triangle$ 40mohm MAX. 275mohm MAX. (AWG#36) 360mohm MAX. (AWG#38) 600mohm MAX. (AWG#40) 700mohm MAX. (AWG#42) 1080mohm MAX. (AWG#44)
GROUND SHELL RESISTANCE	INITIAL : 50mohm MAX. / AFTER TEST : $\triangle$ 40mohm MAX.
INSULATION RESISTANCE	INITIAL : 1000Mohm MIN. / AFTER TEST : 500Mohm MIN.
DIELECTRIC WITHSTANDING VOLTAGE	AC250V 1min
DURABILITY	30 CYCLES
MATING FORCE (INITIAL / AFTER 30 CYCLES)	10P : 7.80N MAX.    40P : 19.40N MAX. 12P : 8.20N MAX.    50P : 24.25N MAX. 20P : 9.70N MAX.    60P : 29.10N MAX. 30P : 14.55N MAX.
UNMATING FORCE (INITIAL / AFTER 30 CYCLES)	10P : 1.00N MIN.    40P : 4.00N MIN. 12P : 1.20N MIN.    50P : 5.00N MIN. 20P : 2.00N MIN.    60P : 6.00N MIN. 30P : 3.00N MIN.
CABLE RETENTION FORCE	10P : 4.90N MIN.    40P : 19.60N MIN. 12P : 5.88N MIN.    50P : 24.50N MIN. 20P : 9.80N MIN.    60P : 29.40N MIN. 30P : 14.70N MIN.
COPLANARITY	0.10 MAX.
PRODUCT SPECIFICATION	PRS-1968
TEST REPORT	TR-14122 (20525-0**E-0#) / TR-16023 (20525-2**E-0#)
PACKING STANDARD	300-824
INSTRUCTION MANUAL	HIM-09008
ASSEMBLY MANUAL	ASM-09005
APPEARANCE CRITERIA No.	QLS-A***

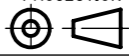
ANGLE	$\pm 2^\circ$	6 OVER 30 MAX.	$\pm 0.3$	PROJECTION 	SERIES No. R7	CUSTOMER COPY		
	6 MAX.	$\pm 0.2$	30 OVER 120 MAX.					
GENERAL TOLERANCE.				TITLE CABLIN <sup>®</sup> -CA RECE. ASSY	SCALE 5:1 UNIT mm	I-PEX		
DWG.	DATE							
CHK.								
APP.								
				DWG. No.	20525	SIZE A3	SHEET 3/6	REV. 25

PART NO.	POS.	A	B	E	G	H	J	K
20525-#10E-02	10	5.40	3.60	-	8.18	9.60	11.60	-
20525-#12E-02	12	6.20	4.40	2.40	8.98	10.40	12.40	-
20525-#20E-02	20	9.40	7.60	4.80	12.18	13.60	15.60	2.40
20525-#30E-02	30	13.40	11.60	9.60	16.18	17.60	19.60	2.40
20525-#40E-02	40	17.40	15.60	12.00	20.18	21.60	23.60	2.40
20525-#50E-02	50	21.40	19.60	16.80	24.18	25.60	27.60	2.80
20525-#60E-02	60	25.40	23.60	19.20	28.18	29.60	31.60	3.20

# PATENT REGISTERED

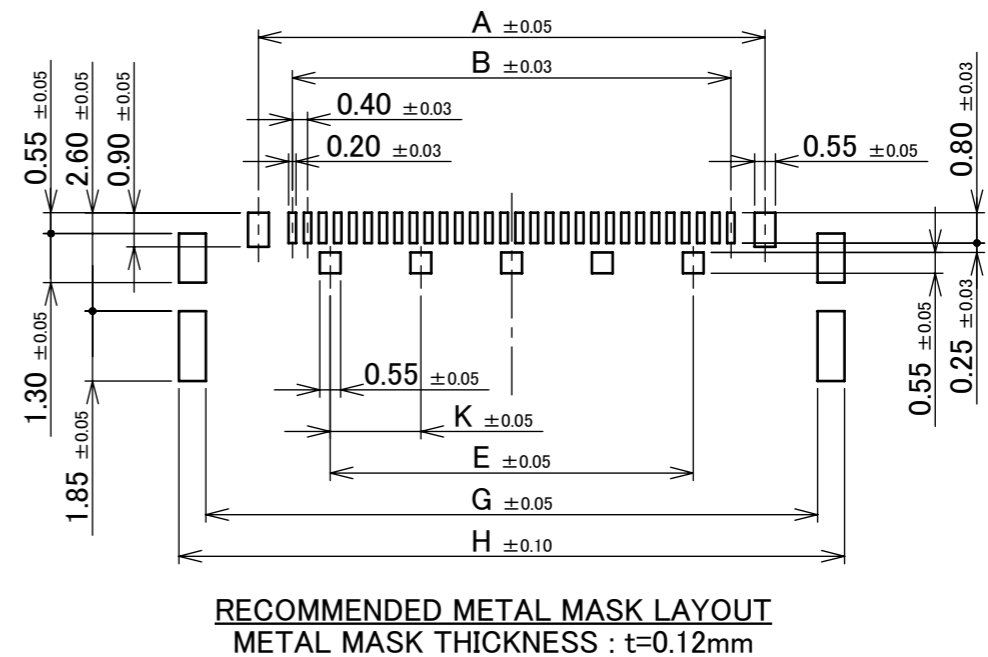
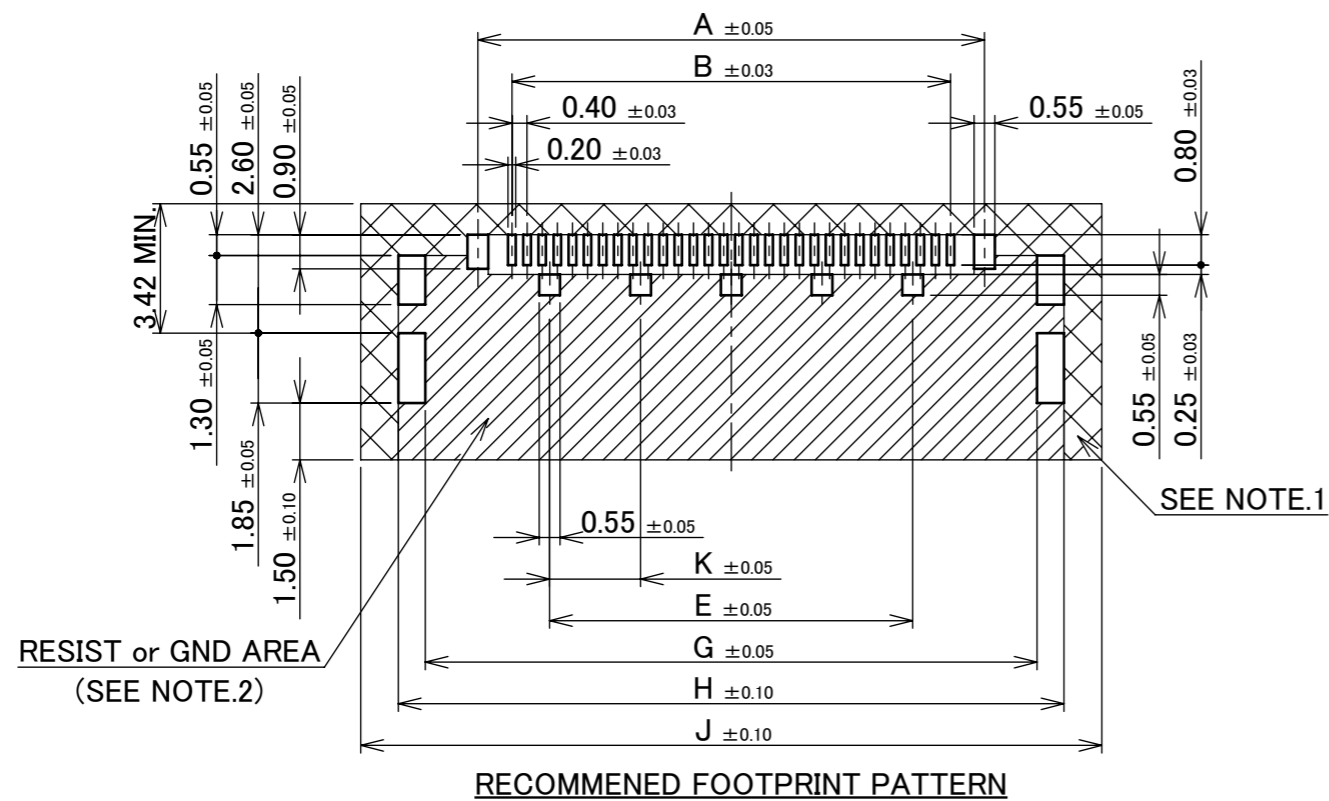

- NOTES.
1. IN CASE OF PLUG WITH PULL BAR(20633-\*\*\*T-01S), THIS AREA CANNOT MOUNT ANOTHER COMPONENTS.
  2. SOLDER RESIST SHALL BE APPLIED TO PREVENT SHORT CIRCUITS WHEN PLACING SIGNAL LINES ON GROUND AREA.

ANGLE	±2°	6 OVER 30 MAX.	±0.3	PROJECTION ⊕	SERIES No. R7	CUSTOMER COPY		
6 MAX.	±0.2	30 OVER 120 MAX.	±0.5					
GENERAL TOLERANCE.				TITLE CABLIN <sup>®</sup> -CA RECE. ASSY	SCALE 5:1	UNIT <b>I-PEX</b>		
DWG.	DATE							
CHK.								
APP.								
				DWG. No.	20525	SIZE A3	SHEET 4/6	REV. 25

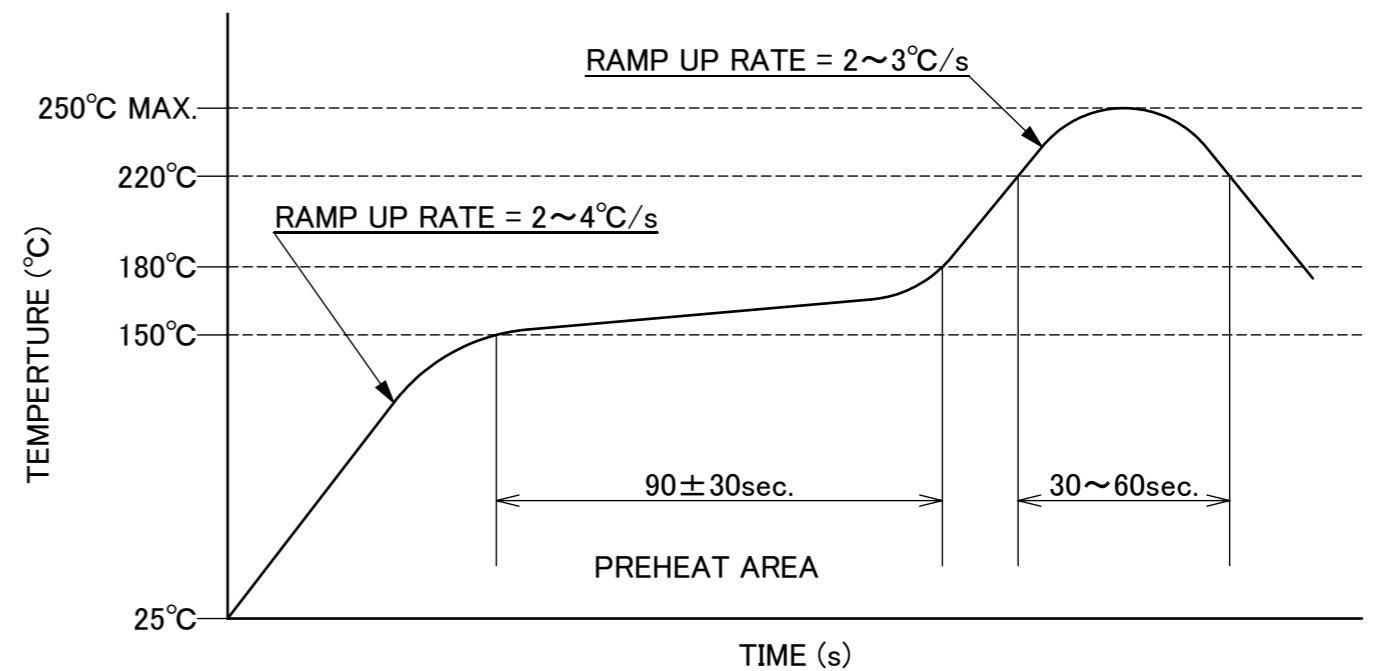
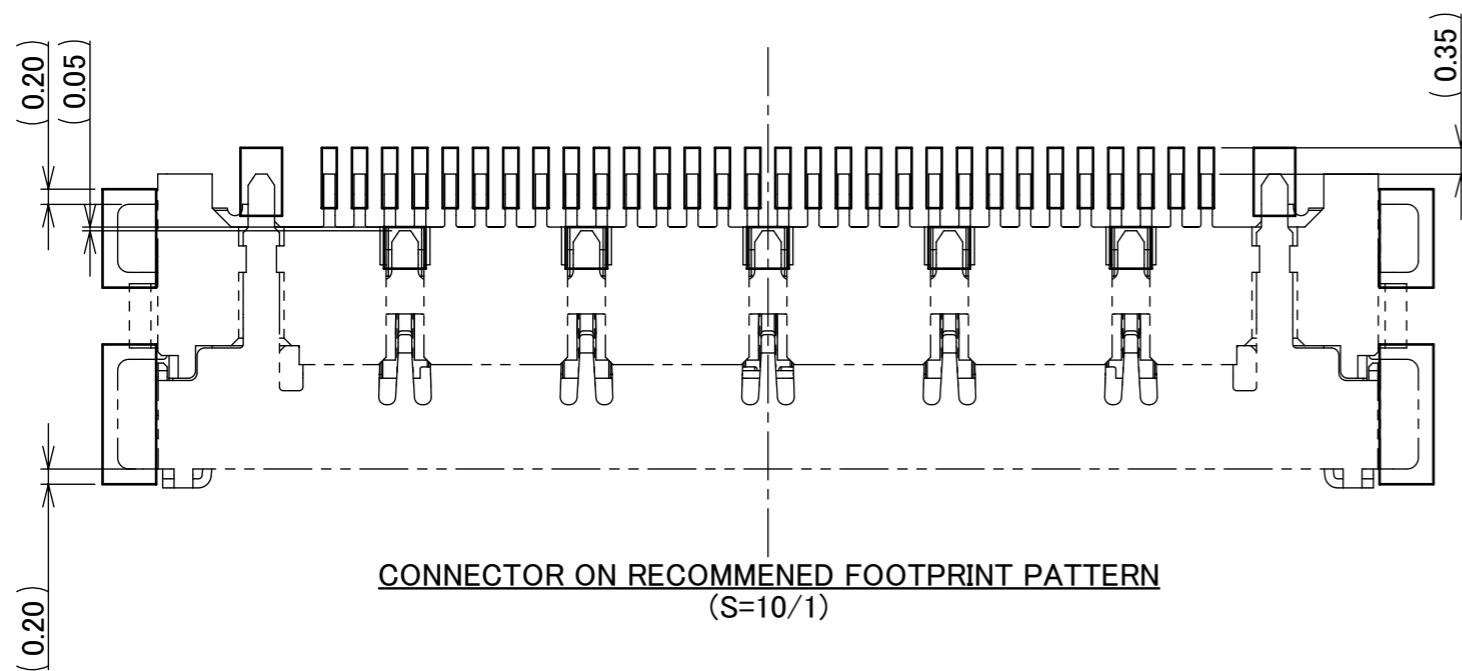

ANGLE	±2°	6 OVER 30 MAX.	±0.3	PROJECTION ⊕	SERIES No. R7	CUSTOMER COPY				
6 MAX.	±0.2	30 OVER 120 MAX.	±0.5							
GENERAL TOLERANCE.				TITLE CABLIN <sup>®</sup> -CA RECE. ASSY		SCALE	<b>I-PEX</b>			
DWG.	DATE					5:1				
CHK.						UNIT				mm
APP.						SIZE				SHEET
				DWG. No.	20525	A3	5/6	25		

PART NO.	M	N	P	Q	R	S	T	REEL QTY.	QTY. IN EMBOSS TAPE (1 REEL)	QTY. IN PACKING CARTON (1 CARTON)
20525-#10E-02	6.35	5.80	8.00	9.60	11.50	-	24.00	5 REELS	5000	5000 × 5 = 25000
20525-#12E-02	7.15	6.60	8.80	10.40	11.50	-	24.00			
20525-#20E-02	10.35	9.80	12.00	13.60	11.50	-	24.00			
20525-#30E-02	14.35	13.80	16.00	17.60	14.20	28.40	32.00	4 REELS	5000	5000 × 4 = 20000
20525-#40E-02	18.35	17.80	20.00	21.60	14.20	28.40	32.00			
20525-#50E-02	22.35	21.80	24.00	25.60	20.20	40.40	44.00	3 REELS	5000	5000 × 3 = 15000
20525-#60E-02	26.35	25.80	28.00	29.60	20.20	40.40	44.00			

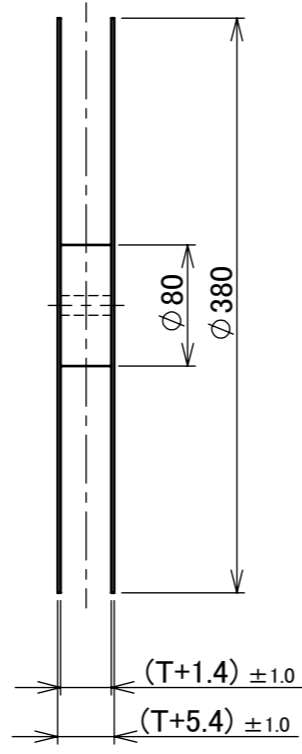
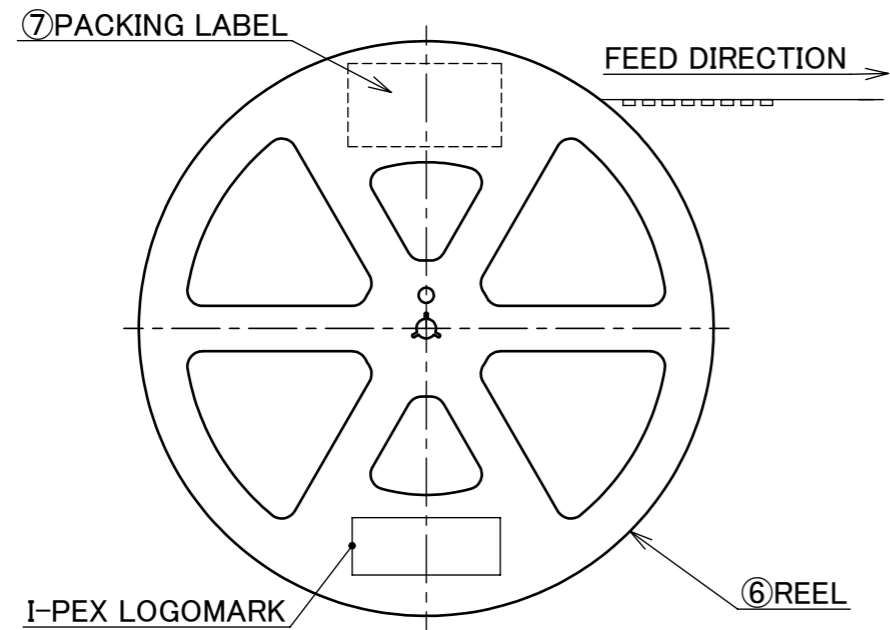

P/N : 20525- # \*\* E- 0 2  
 POS. SEE TABLE 1 (SHEET1/6)

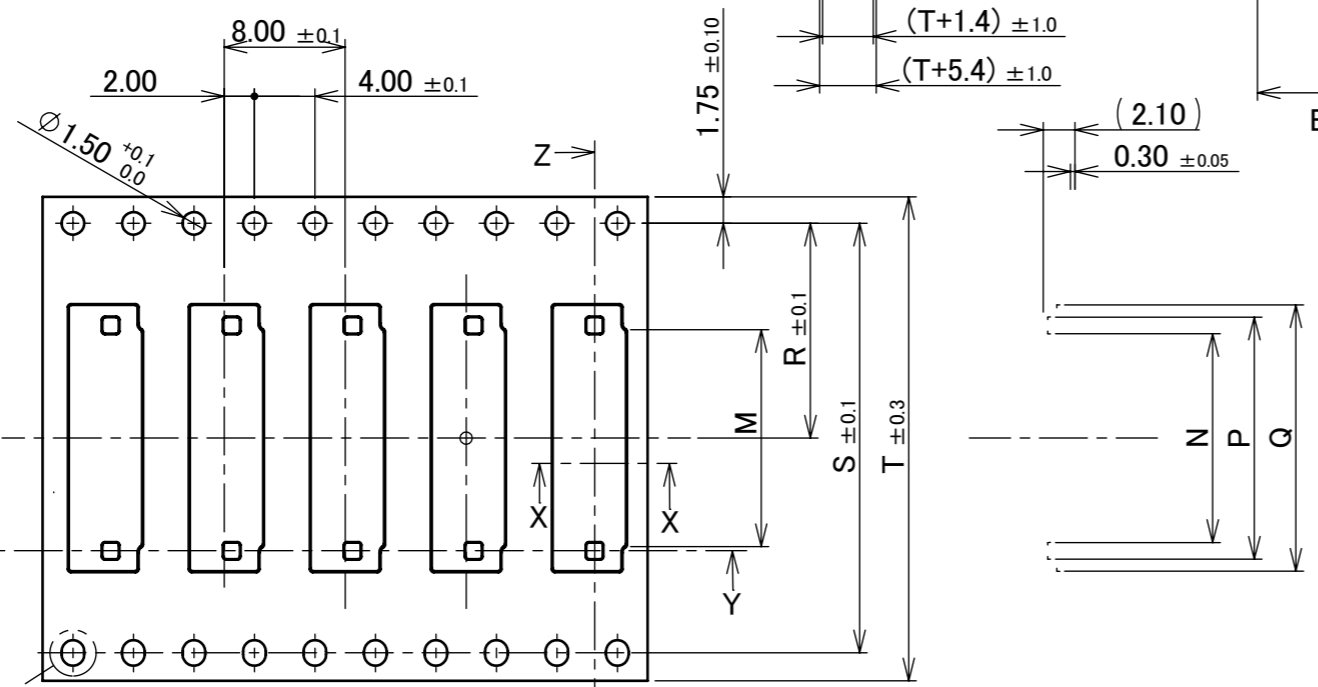
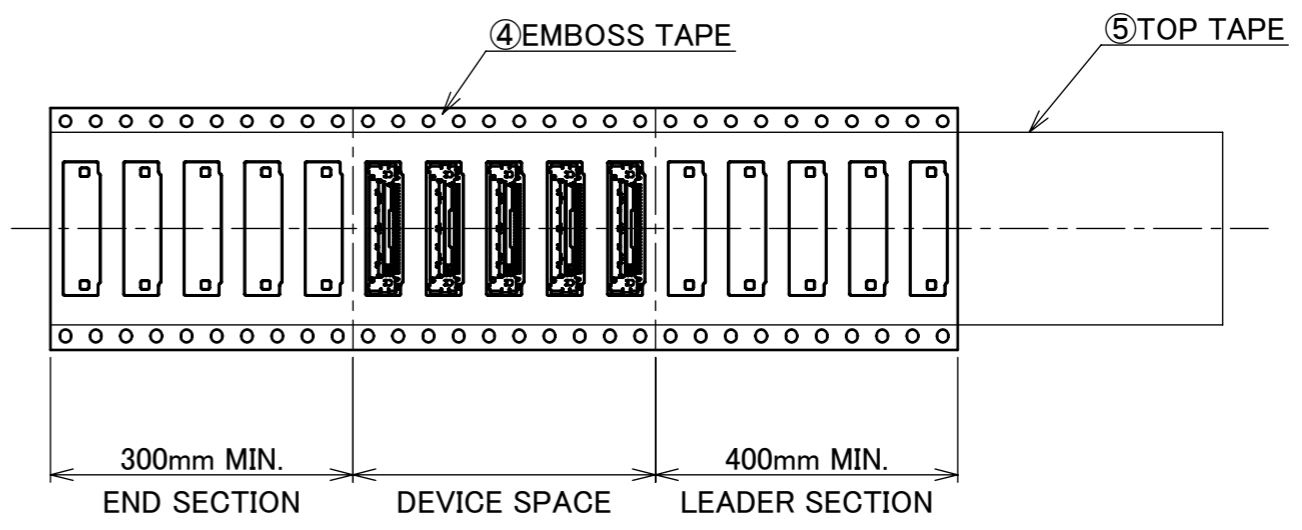

- NOTES.  
 3. TAPING SPECIFICATION FOLLOWS JIS C 0806 (IEC 60286-3).  
 4. MAKE EMPTY SECTION OF LEADER AND END ON EACH END OF THE TAPE.  
 5. TOP TAPE SHALL NOT STICK OUT FROM EMBOSS TAPE.  
 6. TOP TAPE SHALL NOT COVER FEED HOLE.

NO.	DISCRIPTION	MATERIAL	FINISH , REMARKS
7	PACKING LABEL	-	-
6	REEL	PS	BLACK
5	TOP TAPE	PET t=0.061 TRANSPARENCY	ANTI-STATIC TYPE ADHESIVE TYPE
4	EMBOSS TAPE	PS t=0.30 TRANSPARENCY	ANTI-STATIC TYPE

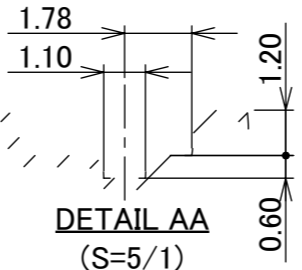
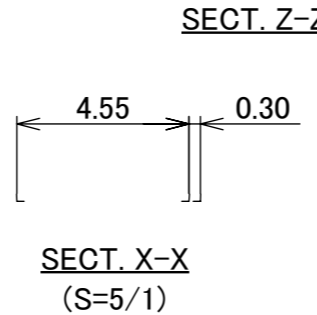
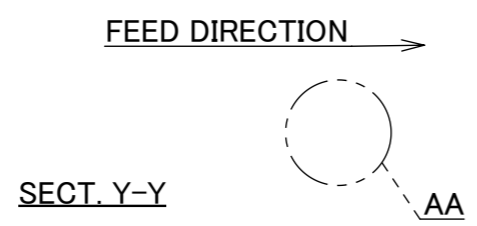
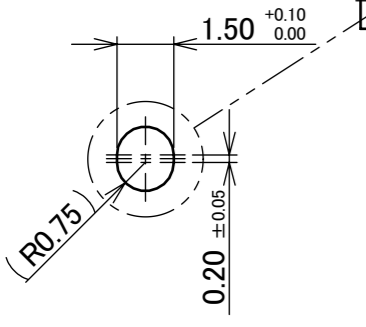

ANGLE	±2°	6 OVER 30 MAX.	±0.3	PROJECTION	SERIES No.	CUSTOMER COPY			
6 MAX.	±0.2	30 OVER 120 MAX.	±0.5		R7	SCALE	<b>I-PEX</b>		
GENERAL TOLERANCE.						TITLE			2:1
DWG.	DATE				CABLIN® -CA RECE. ASSY	UNIT			
CHK.					DWG. No.	mm			
APP.					20525	SIZE	SHEET	REV.	
						A3	6/6	25	