

Recommended P/N 20633-2**T-01S(12~60P) 20633-310T-01S(10P)

PART NO.	POS.	A	B	C	D	E	F	G
20633-#10T-01S	10	3.60	4.40	6.66	9.40	4.65	9.75	10.95
20633-#12T-01S	12	4.40	5.20	7.46	10.20	5.45	10.55	11.75
20633-#20T-01S	20	7.60	8.40	10.66	13.40	8.65	13.75	14.95
20633-#30T-01S	30	11.60	12.40	14.66	17.40	12.65	17.75	18.95
20633-#40T-01S	40	15.60	16.40	18.66	21.40	16.65	21.75	22.95
20633-#50T-01S	50	19.60	20.40	22.66	25.40	20.65	25.75	26.95
20633-#60T-01S	60	23.60	24.40	26.66	29.40	24.65	29.75	30.95

P/N : 20633-#**T-0#S

1 : WITH PULL BAR
2 : WITHOUT PULL BAR
Pos.
SEE TABLE.1

WITH PULL BAR

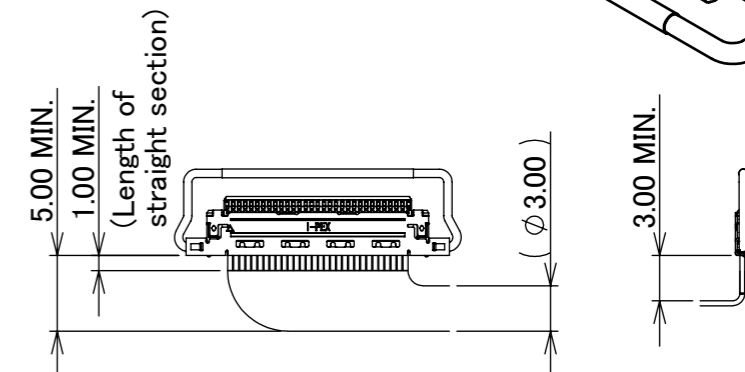
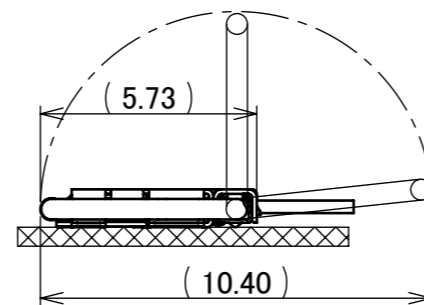
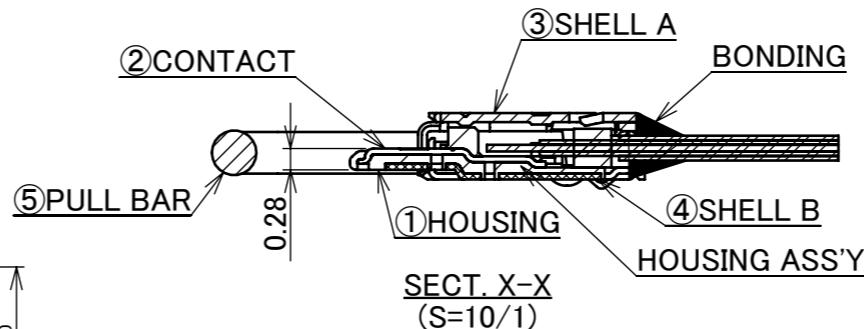
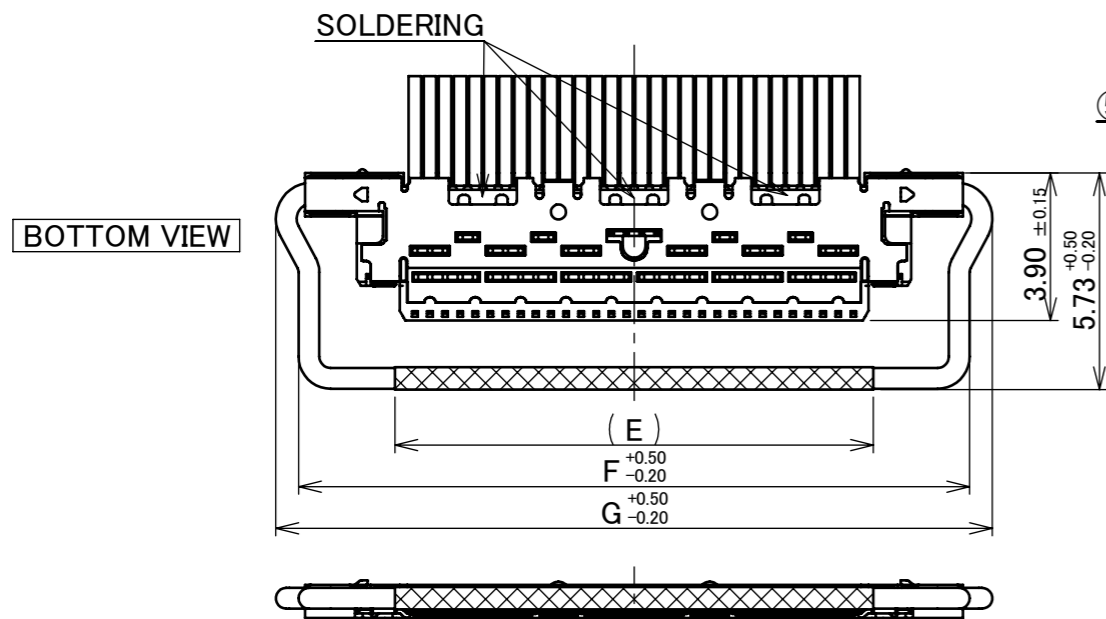
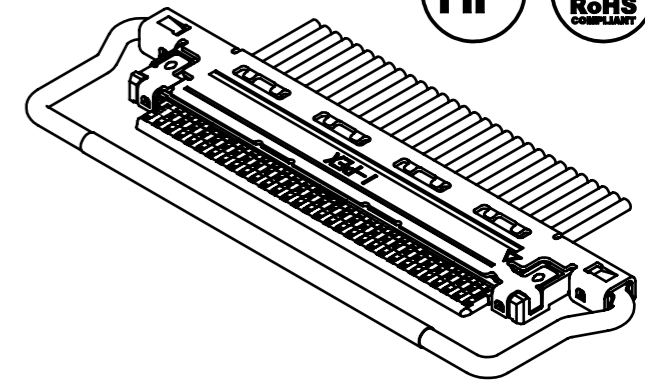
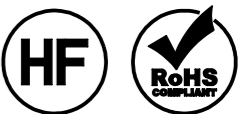

RECOMMENDED CABLE BENDING DIMENSIONS

PART NO.

CABLE ASS'Y PART NO.	HOUSING ASS'Y PART NO.	SHELL A PART NO.	PULL BAR PART NO.
20633-2**T-01S	20634-1**T-02	2764-0**1-002	2766-0**1
20633-3**T-01S	20634-2**T-02	2764-0**1-003	

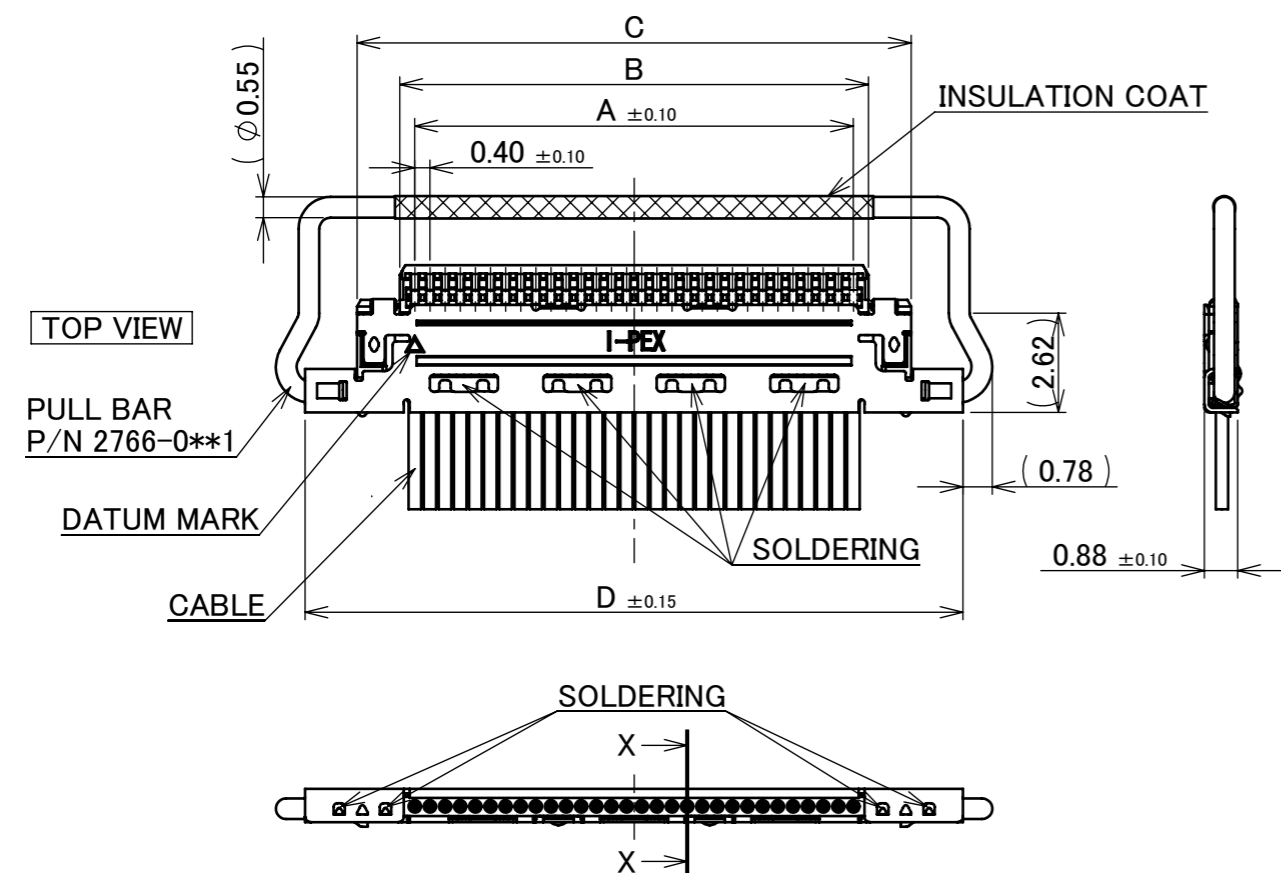

PATENT REGISTERED

TABLE.1

PART NO.	CONTACT FINISH	SHELL A FINISH	SHELL B FINISH
20633-2**T-0#S	CONTACT AREA Au 0.1 μm MIN. OVER Ni 1.00 μm MIN. SOLDERING AREA Au 0.05 μm MIN. OVER Ni 1.00 μm MIN.	TOP SIDE Au 0.03 μm MIN. OVER Ni 1.00 μm MIN. BOTTOM SIDE Ni 1.00 μm MIN.(THERE IS THE POSSIBILITY THAT Au ATTACHES RANDOMLY)	TOP SIDE Ni 1.00 μm MIN.(THERE IS THE POSSIBILITY THAT Au ATTACHES RANDOMLY) BOTTOM SIDE Au 0.03 μm MIN. OVER Ni 1.00 μm MIN.
20633-3**T-0#S	CONTACT AREA Au 0.03 μm MIN. OVER Ni 1.00 μm MIN. SOLDERING AREA Au 0.03 μm MIN. OVER Ni 1.00 μm MIN.	PARTIAL Au 0.003 μm MIN. OVER Ni 1.00 μm MIN.	PARTIAL Au 0.003 μm MIN. OVER Ni 1.00 μm MIN.

NO.	DISCRIPTION	MATERIAL	FINISH , REMARKS
5	PULL BAR	SUS	
4	SHELL B	PHOSPHOR BRONZE	SEE ABOVE TABLE.1
3	SHELL A	PHOSPHOR BRONZE	SEE ABOVE TABLE.1
2	CONTACT	PHOSPHOR BRONZE	SEE ABOVE TABLE.1
1	HOUSING	LCP	UL94V-0, BLACK

REV.	ECN	BY	DATE	APP.	APP.	DATE	PROJECTION	SERIES No.	CUSTOMER COPY		
9	Z210833	M.N	July/26/'21	H.I	ANGLE	±2°	6 OVER 30 MAX.	±0.3	R1R4R1		
8	Z181387	K.Hara	Oct./26/'18	Y.S	6 MAX.	±0.2	30 OVER 120 MAX.	±0.5			
7	Z181125	M.N	Aug./29/'18	Y.S	GENERAL TOLERANCE.			TITLE CABLINER® -CA PLUG FOR CABLE ASSEMBLY	SCALE		
6	Z180930	M.N	July/17/'18	H.I	DWG.	H.Mashima	DATE		2014/08/11	5:1	
5	Z180791	M.N	June/19/'18	Y.S	CHK.	J.Tateishi	DATE		2014/08/11	UNIT	
4	Z180722	M.N	June/05/'18	Y.S	APP.	E.Kawabe	DATE		2014/08/18	mm	
REV.	ECN	BY	DATE	APP.	APP.	DATE	DWG. No.	20633	SIZE	SHEET	REV.
REVISION RECORD									A3	1/5	9

Recommended P/N 20633-2**T-01S(12~60P) 20633-310T-01S(10P)

PART NO.	POS.	A	B	C	D
20633-#10T-02S	10	3.60	4.40	6.66	9.40
20633-#12T-02S	12	4.40	5.20	7.46	10.20
20633-#20T-02S	20	7.60	8.40	10.66	13.40
20633-#30T-02S	30	11.60	12.40	14.66	17.40
20633-#40T-02S	40	15.60	16.40	18.66	21.40
20633-#50T-02S	50	19.60	20.40	22.66	25.40
20633-#60T-02S	60	23.60	24.40	26.66	29.40

P/N : 20633-#**T-0#S
 1 : WITH PULL BAR
 2 : WITHOUT PULL BAR
 Pos.
 SEE TABLE.1 (SHEET1/5)

WITHOUT PULL BAR

BOTTOM VIEW

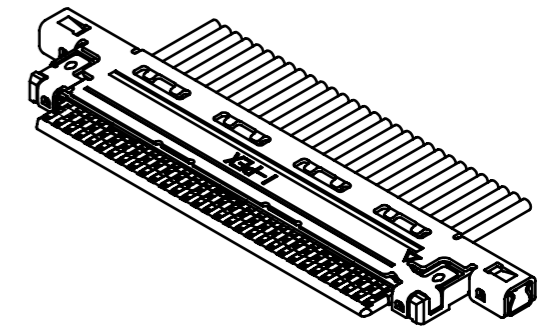
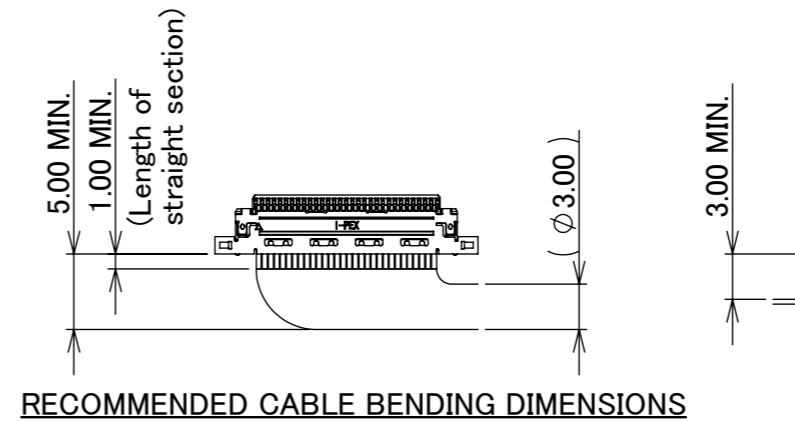
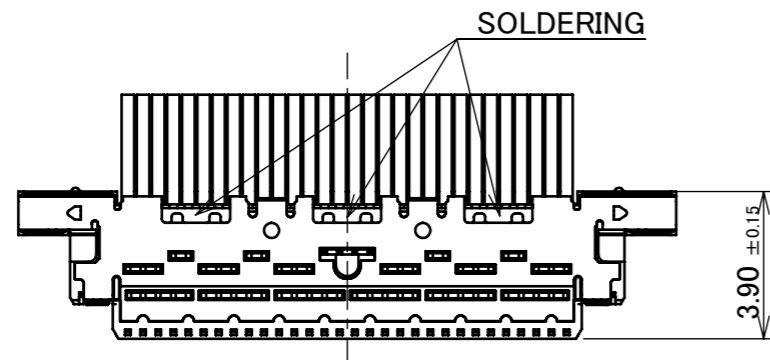

TOP VIEW

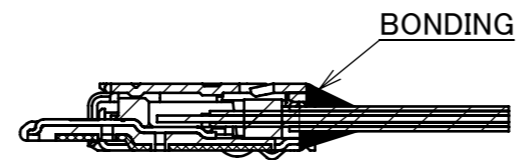
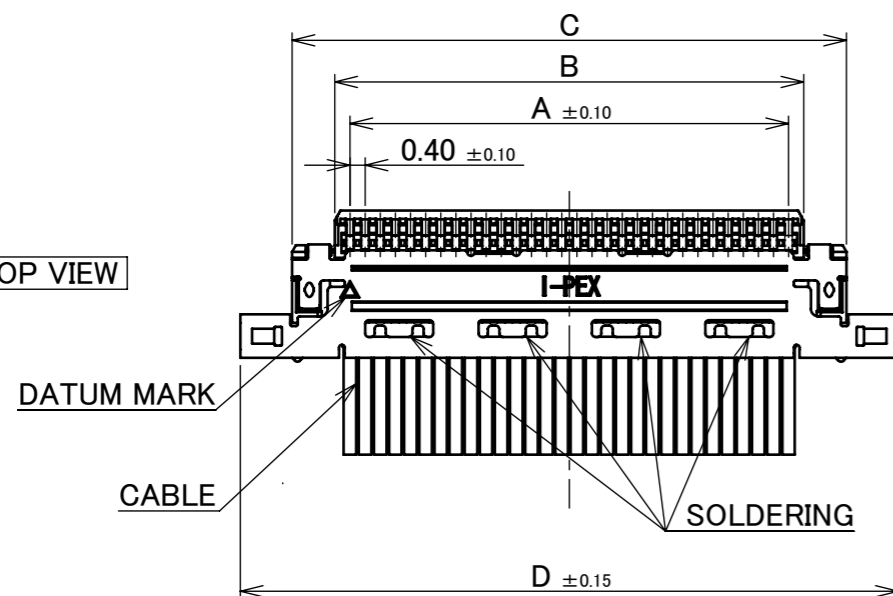

SECT. X-X
(S=10/1)

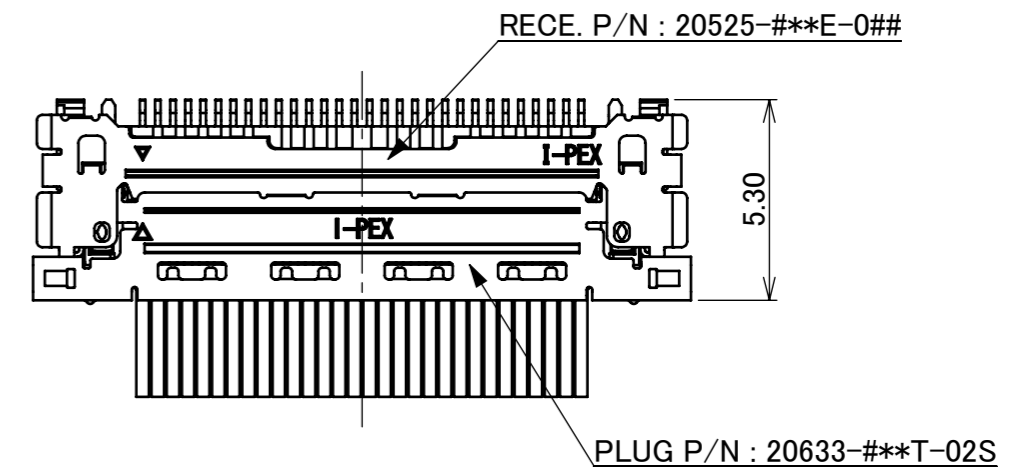
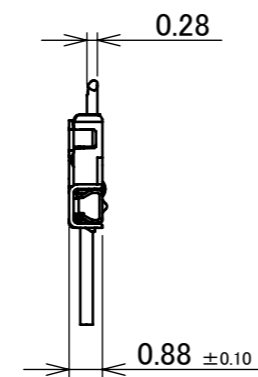

PART NO.

CABLE ASS'Y PART NO.	HOUSING ASS'Y PART NO.	SHELL-A PART NO.	PULL BAR PART NO.
20633-2**T-02S	20634-1**T-02	2764-0**1-002	-
20633-3**T-02S	20634-2**T-02	2764-0**1-003	-

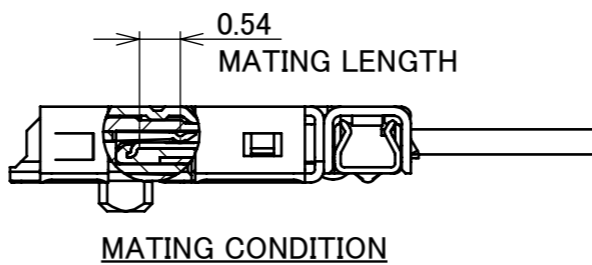
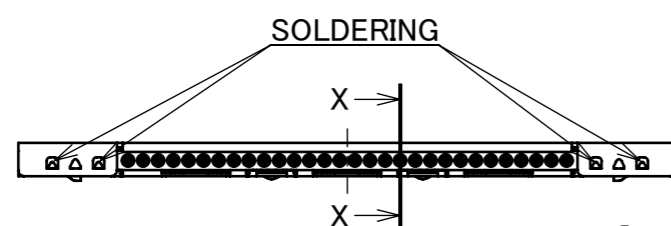

PATENT REGISTERED

ANGLE	±2°	6 OVER 30 MAX.	±0.3	PROJECTION ⊕	SERIES No. R1R4R1	CUSTOMER COPY			
	6 MAX.	±0.2	30 OVER 120 MAX.						±0.5
GENERAL TOLERANCE.						TITLE CABLINEX® -CA PLUG FOR CABLE ASSEMBLY	SCALE	I-PEX	
DWG.	DATE		5:1						
CHK.			UNIT						
APP.			mm						
DWG. No. 20633						SIZE	SHEET	REV.	
						A3	2/5	9	

ITEMS	SPECIFICATION
APPLICABLE CABLE	MICRO COAX : AWG# 44 , 42 , 40 , 38 , 36 DISCRETE : AWG# 36, 34 TWINCOAX : AWG# 40
RATING VOLTAGE	100V AC (PER A CONTACT)
RATING AMPERAGE (FOR CONTACT)	0.1A AC/DC [AWG#44] PER CONTACT/UP TO 60 CONTACTS 0.24A AC/DC [AWG#42] PER CONTACT/UP TO 50 CONTACTS 0.3A AC/DC [AWG#40] PER CONTACT/UP TO 40 CONTACTS 0.5A AC/DC [AWG#38] PER CONTACT/UP TO 14 CONTACTS 0.8A AC/DC [AWG#36] PER CONTACT/UP TO 6 CONTACTS 1.0A AC/DC [AWG#34] PER CONTACT/UP TO 4 CONTACTS TESTING BY A REAL MACHINE IS RECOMMENDED BECAUSE TEMPERATURE RISE MAY AFFECTED BY ACTUAL SITUATION.
OPERATING TEMPERATURE	233~358K (-40°C~85°C)
OPERATING HUMIDITY	85% MAX. (NON-CONDENDING)
CONTACT RESISTANCE	INITIAL : 180mohm MAX. (AWG#34) / AFTER TEST : \triangleleft 40mohm MAX. 275mohm MAX. (AWG#36) 360mohm MAX. (AWG#38) 600mohm MAX. (AWG#40) 700mohm MAX. (AWG#42) 1080mohm MAX. (AWG#44)
GROUND SHELL RESISTANCE	INITIAL : 50mohm MAX. / AFTER TEST : \triangleleft 40mohm MAX.
INSULATION RESISTANCE	INITIAL : 1000Mohm MIN. / AFTER TEST : 500Mohm MIN.
DIELECTRIC WITHSTANDING VOLTAGE	AC250V 1min
DURABILITY	30 CYCLES
MATING FORCE (INITIAL / AFTER 30 CYCLES)	10P : 7.80N MAX. 40P : 19.40N MAX. 12P : 8.20N MAX. 50P : 24.25N MAX. 20P : 9.70N MAX. 60P : 29.10N MAX. 30P : 14.55N MAX.
UNMATING FORCE (INITIAL / AFTER 30 CYCLES)	10P : 1.00N MIN. 40P : 4.00N MIN. 12P : 1.20N MIN. 50P : 5.00N MIN. 20P : 2.00N MIN. 60P : 6.00N MIN. 30P : 3.00N MIN.
CABLE RETENTION FORCE	10P : 4.90N MIN. 40P : 19.60N MIN. 12P : 5.88N MIN. 50P : 24.50N MIN. 20P : 9.80N MIN. 60P : 29.40N MIN. 30P : 14.70N MIN.
PRODUCT SPECIFICATION	PRS-1968
TEST REPORT	TR-14122 (20525-0**E-0##) / TR-16023 (20525-2**E-0##)
INSTRUCTION MANUAL	HIM-09008
ASSEMBLY MANUAL	ASM-09005
APPEARANCE CRITERIA No.	QLS-A***

ANGLE	$\pm 2^\circ$	6 OVER 30 MAX.	± 0.3	PROJECTION 	SERIES No. R1R4R1	CUSTOMER COPY		
	6 MAX.	± 0.2	30 OVER 120 MAX.			± 0.5	SCALE 5:1	I-PEX
GENERAL TOLERANCE.				TITLE CABLIN [®] -CA PLUG FOR CABLE ASSEMBLY		UNIT mm		
DWG.	DATE			DWG. No. 20633		SIZE A3	SHEET 3/5	REV. 9
CHK.								
APP.								

PART NO.	POS.	A
20633-#10T-0#S	10	3.60
20633-#12T-0#S	12	4.40
20633-#20T-0#S	20	7.60
20633-#30T-0#S	30	11.60
20633-#40T-0#S	40	15.60
20633-#50T-0#S	50	19.60
20633-#60T-0#S	60	23.60

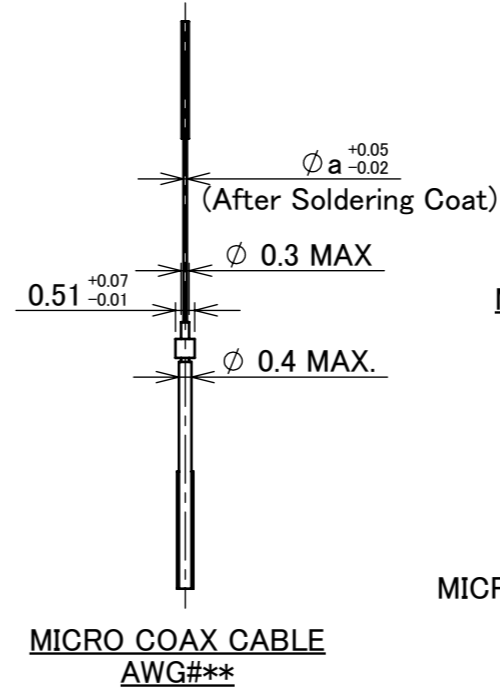
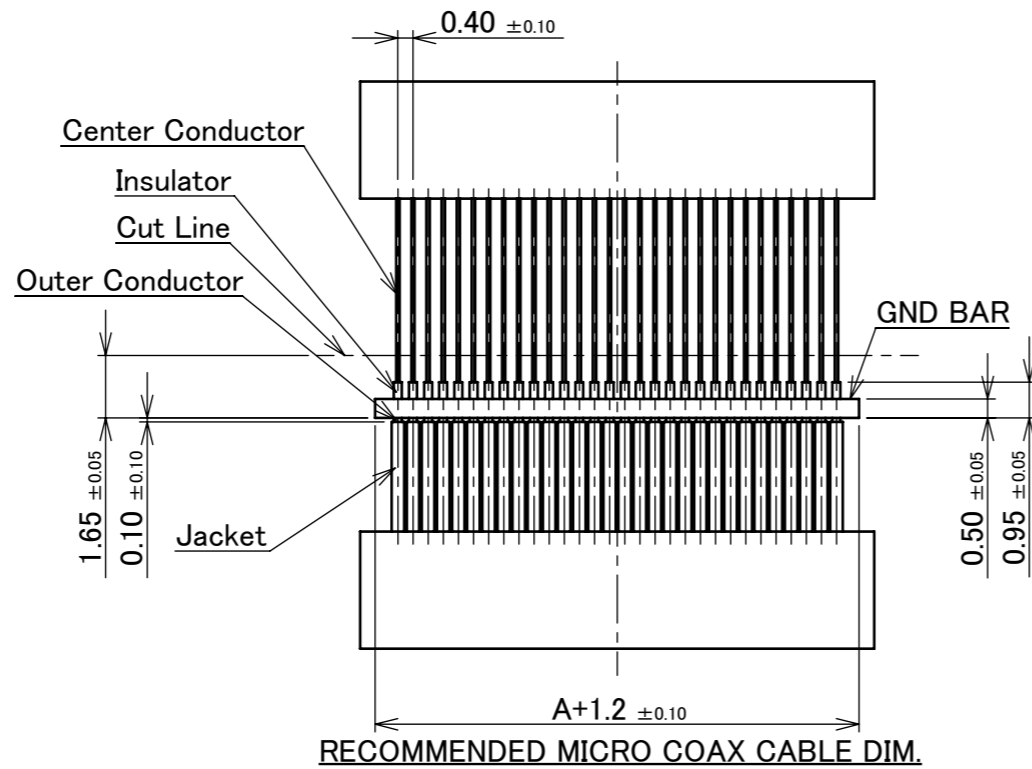

MICRO COAX CABLE DIMENSION

	a
#36	0.15
#38	0.12
#40	0.09
#42	0.075
#44	0.063

MICRO COAX CABLE #36 : NOT RECOMMENDED FOR HIGH SPEED SIGNAL TRANSFER

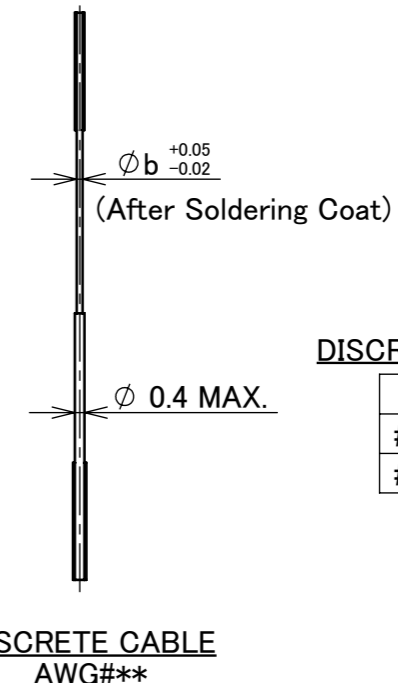
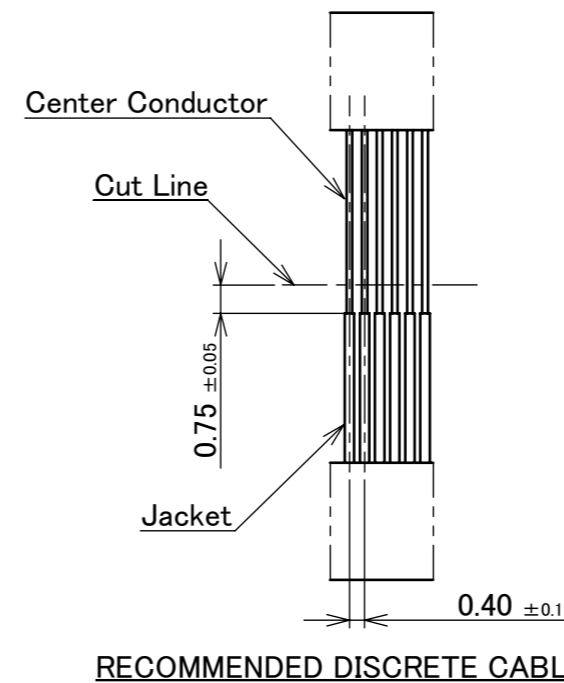
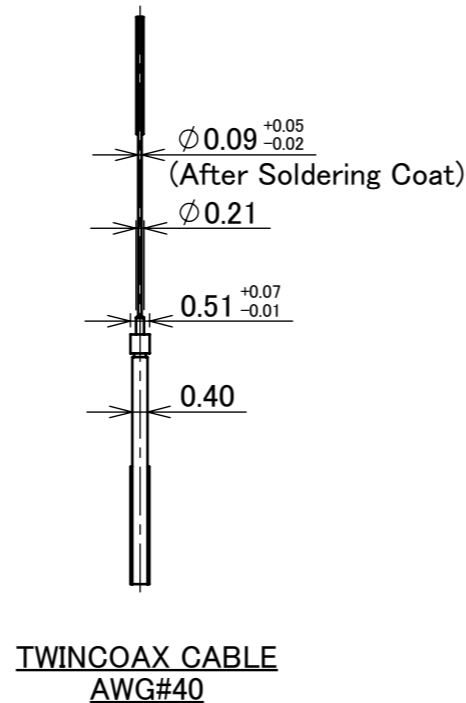
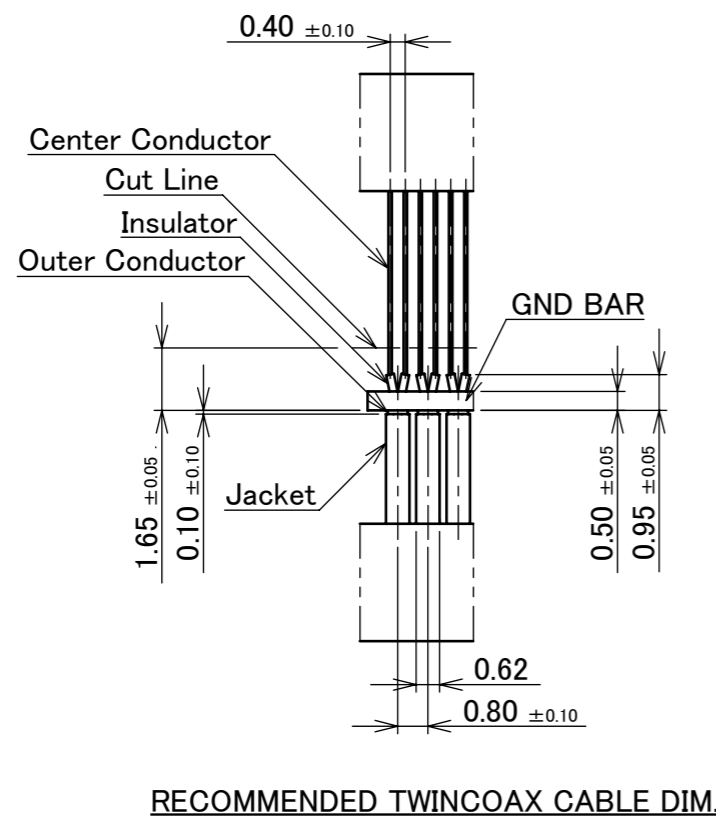

DISCRETE DIMENSION

	b
#34	0.192
#36	0.15

ANGLE	±2°	6 OVER 30 MAX.	±0.3	PROJECTION ⊕	SERIES No. R1R4R1	CUSTOMER COPY						
	6 MAX.	±0.2	30 OVER 120 MAX.						±0.5			
GENERAL TOLERANCE.				TITLE		SCALE	I-PEX					
DWG.	DATE			CABLIN [®] -CA PLUG FOR CABLE ASSEMBLY		5:1						
CHK.						UNIT						
APP.				DWG. No. 20633		mm				SIZE	SHEET	REV.
						A3	4/5	9				

PART NO.
20633-##*T-0#S

THE EXTERNAL APPEARANCE

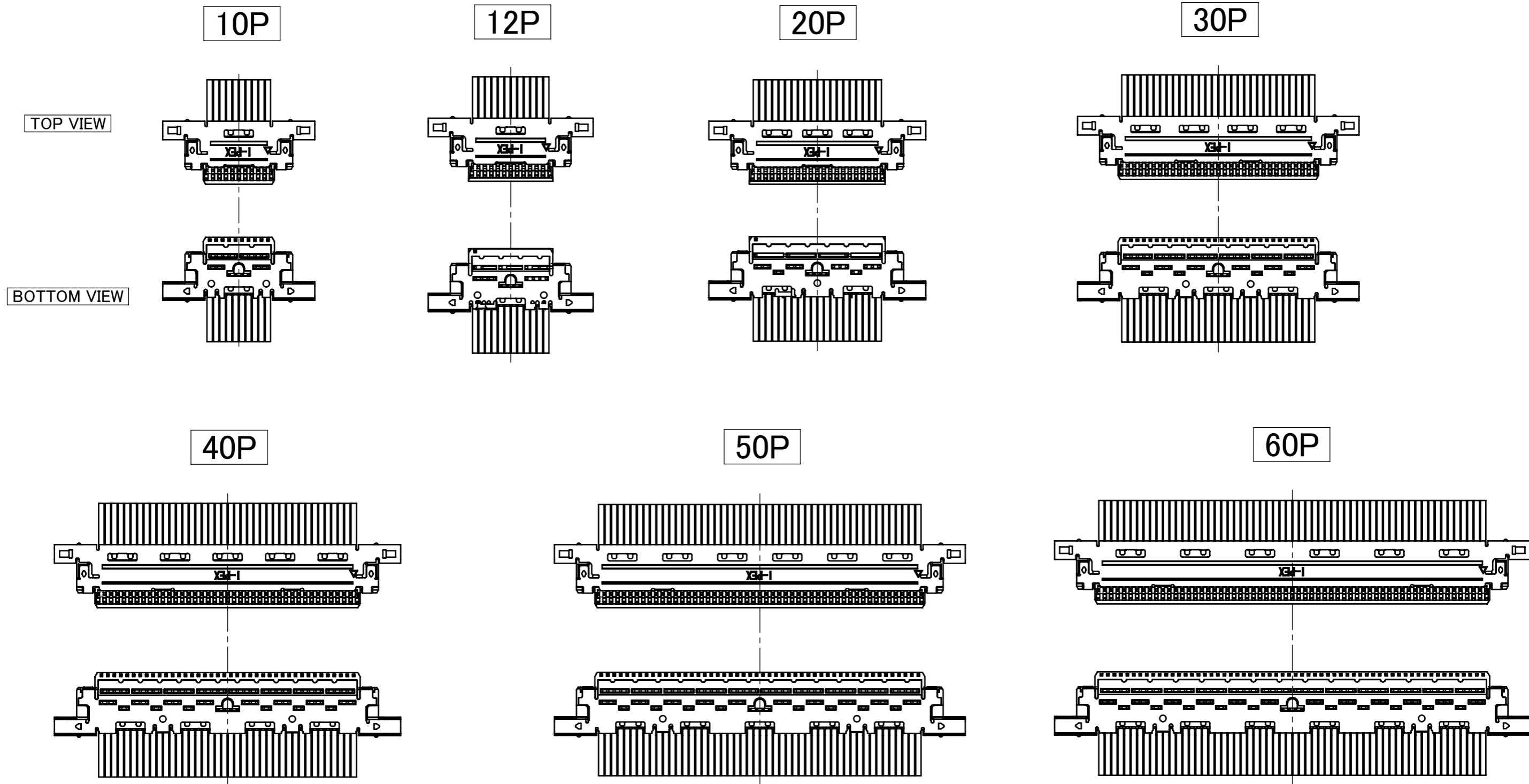

ANGLE	$\pm 2^\circ$	6 OVER 30 MAX.	± 0.3	PROJECTION 	SERIES No. R1R4R1	CUSTOMER COPY		
	6 MAX.	± 0.2	30 OVER 120 MAX.					± 0.5
GENERAL TOLERANCE.				TITLE CABLIN [®] -CA PLUG FOR CABLE ASSEMBLY	SCALE 4:1 UNIT mm	I-PEX		
DWG.	DATE							
CHK.								
APP.								
				DWG. No.	20633	SIZE A3	SHEET 5/5	REV. 9