

Recommended P/N 20682-0\*\*E-02

PART NO.	Pos.	A	B	C	D	E	J	K	L
20682-020E-02#	20	9.40	7.60	12.43	13.20	4.80	2.40	5.60	2.00
20682-030E-02#	30	13.40	11.60	16.43	17.20	9.60	2.40	12.00	1.60
20682-040E-02#	40	17.40	15.60	20.43	21.20	12.00	2.40	14.40	1.60
20682-050E-02#	50	21.40	19.60	24.43	25.20	16.80	2.80	18.40	1.60

P/N : 20682-0\*\*E-02 #

WITHOUT : PACKING QTY. IS 5500 IN REEL.  
-S : PACKING QTY. IS 500 IN REEL.

Pos.

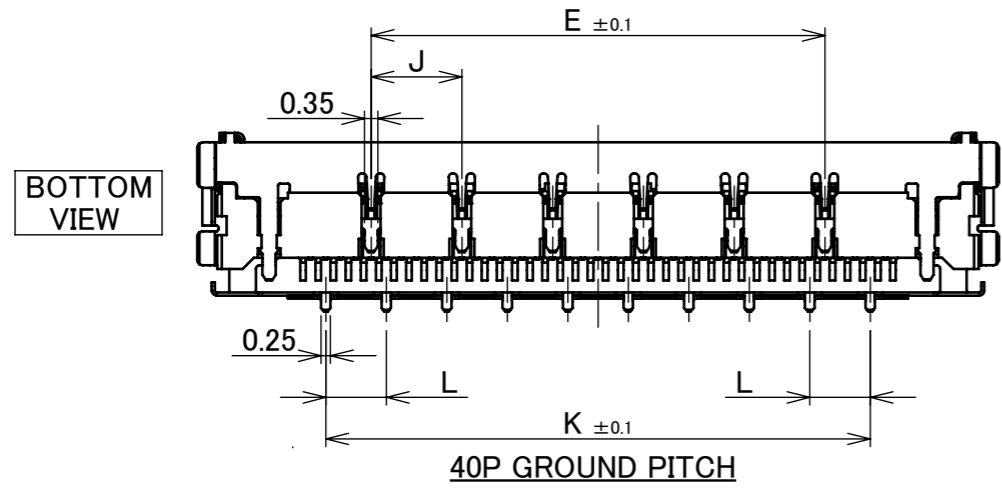
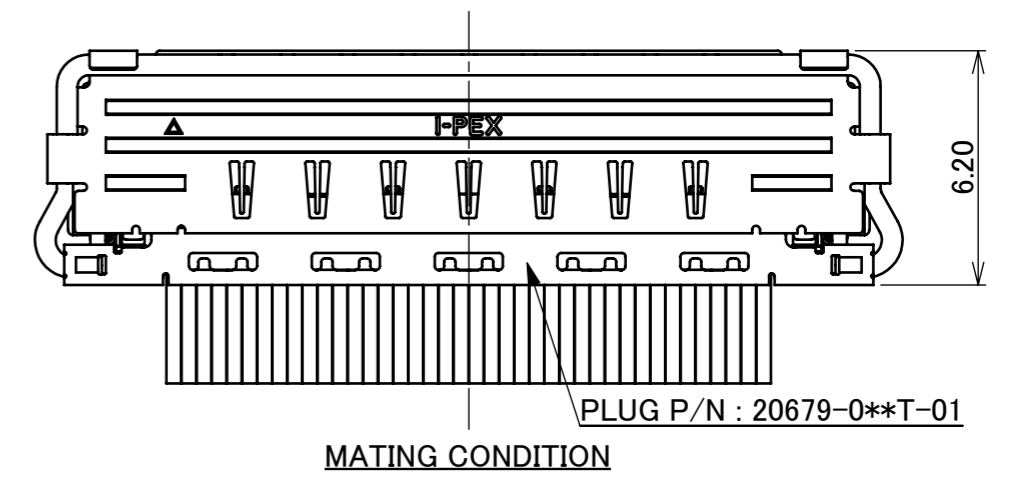
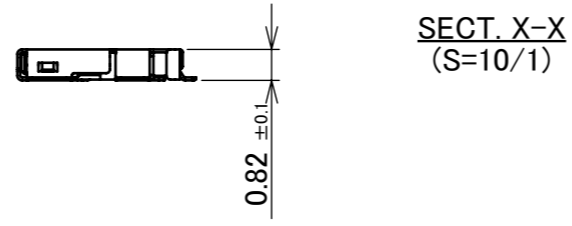
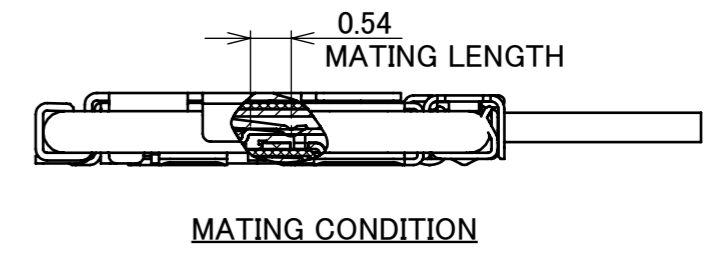
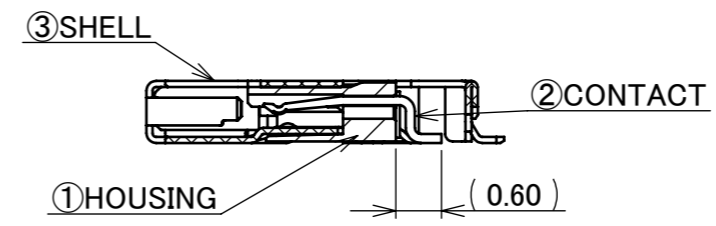
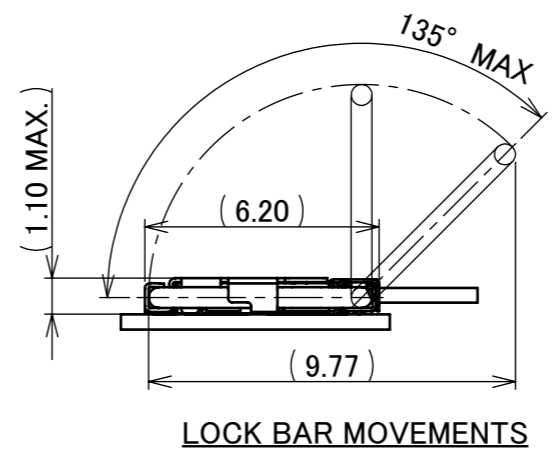
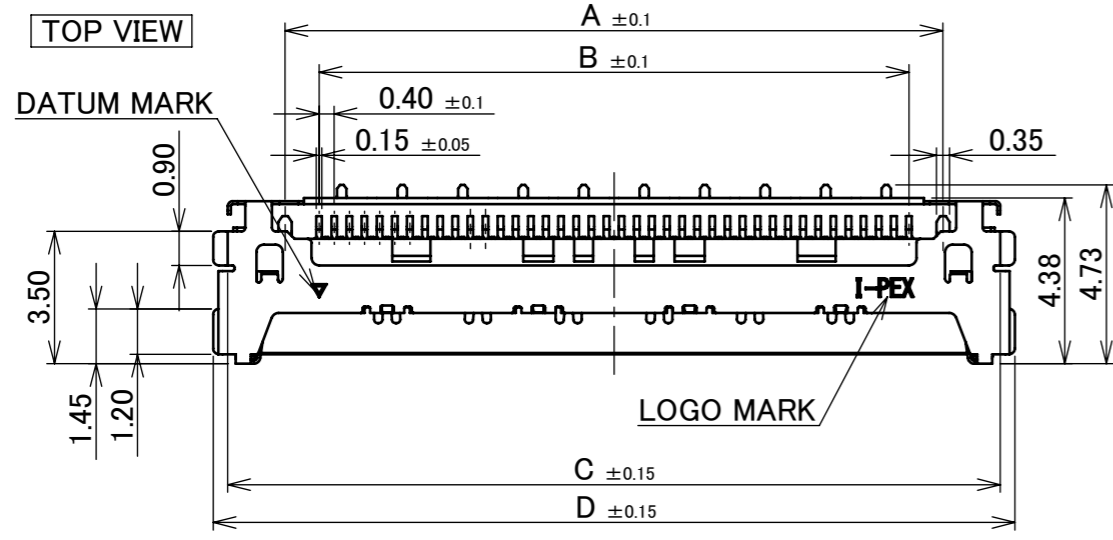
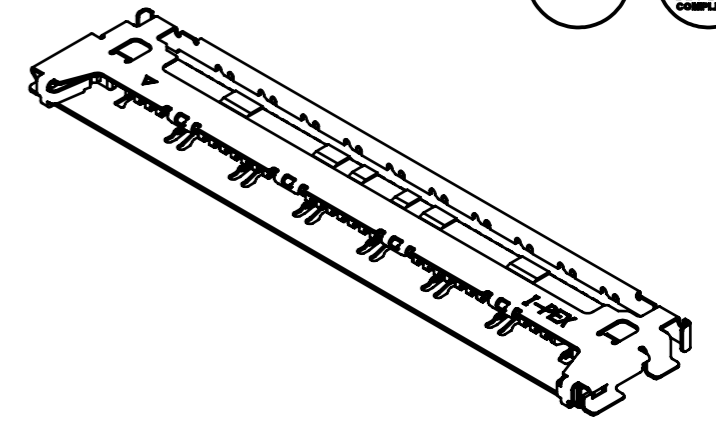
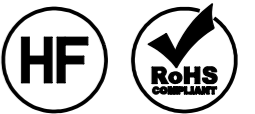

NO.	DISCRIPTION	MATERIAL	FINISH , REMARKS
3	SHELL	PHOSPHOR BRONZE	ALL OVER Ni 1.00 μ m MIN. SOLDERING AREA : Au 0.03 μ m MIN.
2	CONTACT	PHOSPHOR BRONZE	ALL OVER Ni 1.00 μ m MIN. CONTACT & SOLDERING AREA : Au 0.03 μ m MIN.
1	HOUSING	LCP	UL94V-0 ,BLACK

REV.	ECN	BY	DATE	APP.	APP.	DATE	DWG. No.	20682	SIZE	SHEET	REV.
9	Z200950	A.K	Sept./10/'20	Y.S	ANGLE	±2°	6 OVER 30 MAX.	±0.3	PROJECTION	SERIES No. R1	CUSTOMER COPY
8	Z181515	Y.M	Nov./19/'18	H.I	6 MAX.	±0.2	30 OVER 120 MAX.	±0.5			
7	Z180947	A.K	July/19/'18	H.I	GENERAL TOLERANCE.			TITLE CABLINER® -CA II RECE. ASS'Y	SCALE	I-PEX	
6	Z180883	A.K	July/6/'18	H.I	DWG.	DATE	2015/03/24		5:1		
5	Z170214	T.M	Mar./1/'17	H.I	T.Masunaga	DATE		2015/03/24	UNIT		
4	Z161039	T.M	Aug./23/'16	J.T	CHK.	DATE	2015/03/24	mm			
REV.	ECN	BY	DATE	APP.	J.Tateishi	DATE	2015/03/24	SIZE	SHEET	REV.	
REVISION RECORD					E.Kawabe	DATE	2015/03/25	A3	1/7	9	

**PATENT REGISTERED**

PART NO.	Pos.	E	J	K	L
20682-020E-02#	20	4.80	2.40	5.60	2.00
20682-030E-02#	30	9.60	2.40	12.00	1.60
20682-040E-02#	40	12.00	2.40	14.40	1.60
20682-050E-02#	50	16.80	2.80	18.40	1.60

# PATENT REGISTERED

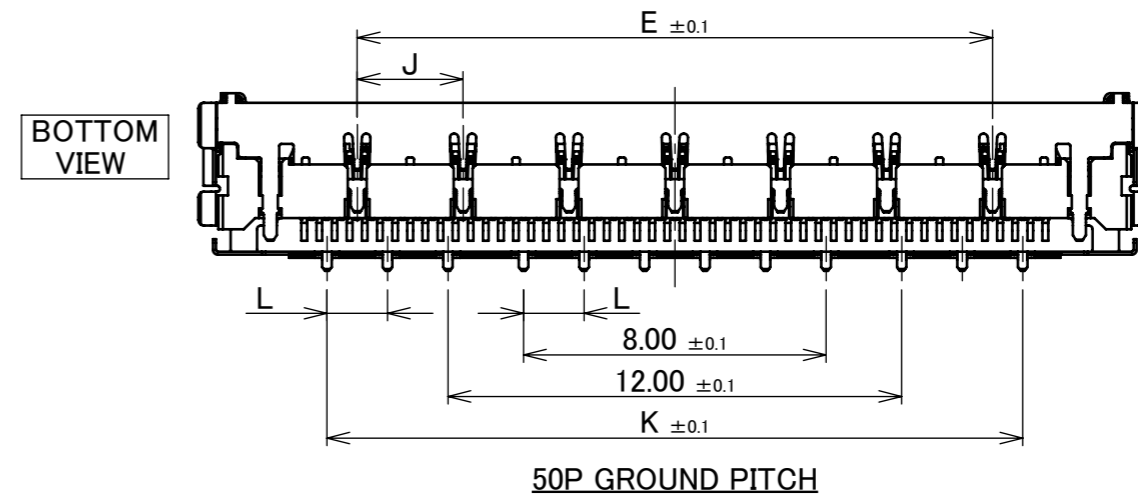
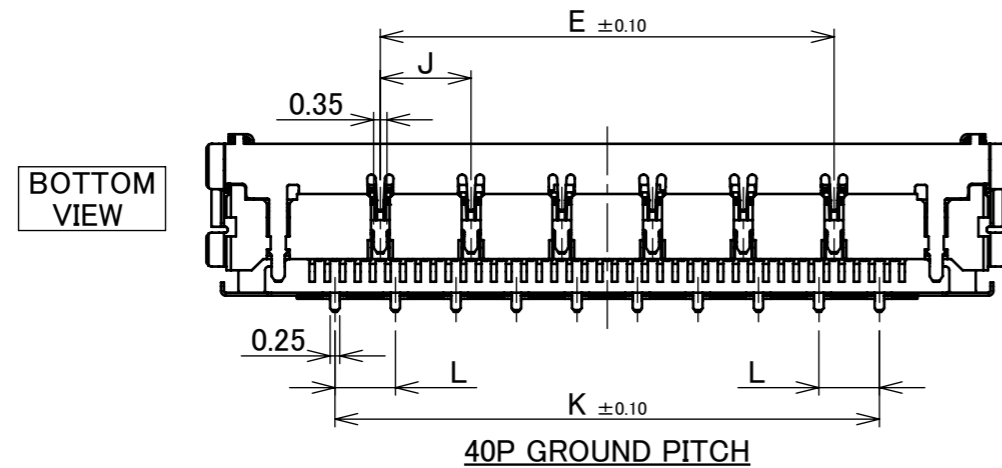
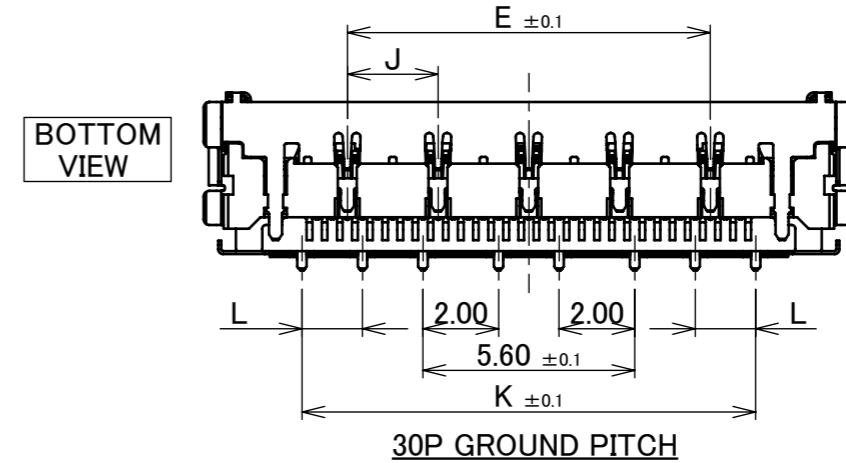
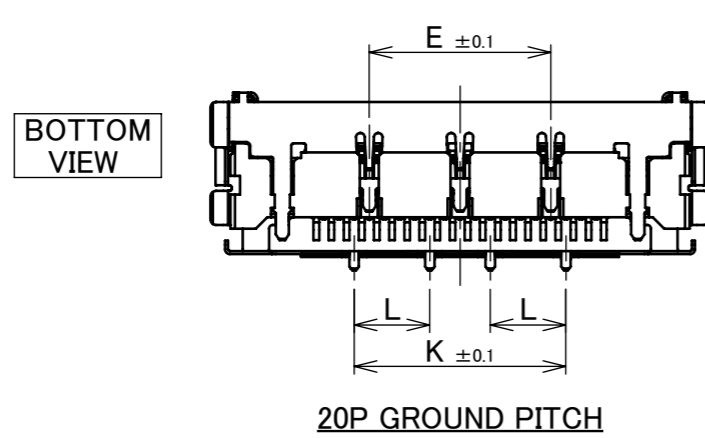

ANGLE	±2°	6 OVER 30 MAX.	±0.3	PROJECTION ⊕	SERIES No. R1	CUSTOMER COPY		
	6 MAX.	±0.2	30 OVER 120 MAX.					±0.5
GENERAL TOLERANCE.				TITLE CABLINÉ® -CA II RECE. ASS'Y	SCALE 5:1	UNIT <b>I-PEX</b>		
DWG.	DATE							
CHK.								
APP.								
				DWG. No.	20682	SIZE A3	SHEET 2/7	REV. 9

ITEMS	SPECIFICATION
APPLICABLE CABLE	MICRO COAX : AWG# 44 , 42 , 40 , 38 , 36 DISCRETE : AWG# 36 , 34 TWINCOAX : AWG# 40
RATING VOLTAGE	100V AC (PER CONTACT)
RATING AMPERAGE (FOR CONTACT)	0.1A AC/DC [AWG#44] PER CONTACT/UP TO 50 CONTACTS 0.24A AC/DC [AWG#42] PER CONTACT/UP TO 50 CONTACTS 0.3A AC/DC [AWG#40] PER CONTACT/UP TO 50 CONTACTS 0.5A AC/DC [AWG#38] PER CONTACT/UP TO 18 CONTACTS 0.8A AC/DC [AWG#36] PER CONTACT/UP TO 6 CONTACTS 1.0A AC/DC [AWG#34] PER CONTACT/UP TO 6 CONTACTS ※TESTING BY A REAL MACHINE IS RECOMMENDED BECAUSE TEMPERTURE RISE MAY AFFECTED BY ACTUAL SITUATION.
OPERATING TEMPERATURE	233~358K(-40°C~85°C)
OPERATING HUMIDITY	85% MAX.(NON-CONDENDING)
CONTACT RESISTANCE	INITIAL : 180mohm MAX.(AWG#34) / AFTER TEST : $\triangleleft$ 40mohm MAX. 275mohm MAX.(AWG#36) 360mohm MAX.(AWG#38) 600mohm MAX.(AWG#40) 700mohm MAX.(AWG#42) 1080mohm MAX.(AWG#44)
GROUND SHELL RESISTANCE	INITIAL : 50mohm MAX. / AFTER TEST : $\triangleleft$ 40mohm MAX.
INSULATION RESISTANCE	INITIAL : 1000Mohm MIN. / AFTER TEST : 500Mohm MIN.
DIELECTRIC WITHSTANDING VOLTAGE	AC250V 1min
DURABILITY	30 CYCLES
MATING FORCE (INITIAL / AFTER 30 CYCLES)	20P : 9.70N MAX. 30P : 14.55N MAX. 40P : 19.40N MAX. 50P : 24.25N MAX.
UN-MATING FORCE (INITIAL / AFTER 30 CYCLES)	20P : 2.0N MIN. 30P : 3.0N MIN. 40P : 4.0N MIN. 50P : 5.0N MIN.
CABLE RETENTION FORCE	20P : 9.70N MIN. 30P : 14.55N MIN. 40P : 19.40N MIN. 50P : 24.25N MIN.
COPLANARITY	0.10 MAX.
PRODUCT SPECIFICATION	PRS-2163
TEST REPORT	TR-15103
INSTRUCTION MANUAL	HIM-15033
PACKING STANDARD	PST-15027
APPEARANCE CRITERIA No.	QLS-A***

ANGLE	$\pm 2^\circ$	6 OVER 30 MAX.	$\pm 0.3$	PROJECTION 	SERIES No. R1	CUSTOMER COPY		
6 MAX.	$\pm 0.2$	30 OVER 120 MAX.	$\pm 0.5$					
GENERAL TOLERANCE.				TITLE CABLIN <sup>®</sup> -CA II RECE. ASS'Y	SCALE 5:1	<b>I-PEX</b>		
DWG.	DATE							
CHK.								
APP.								
DWG. No.	20682			SIZE A3	SHEET 3/7	REV. 9		

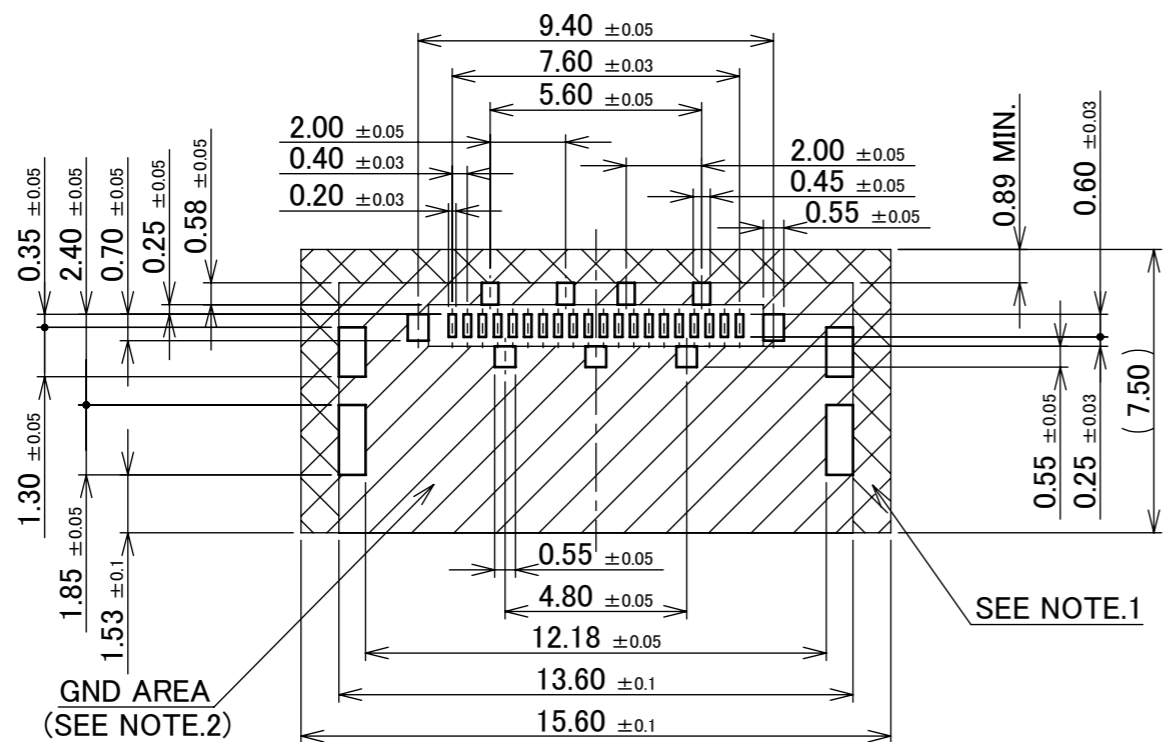

**20P RECOMMENDED FOOTPRINT PATTERN LAYOUT**

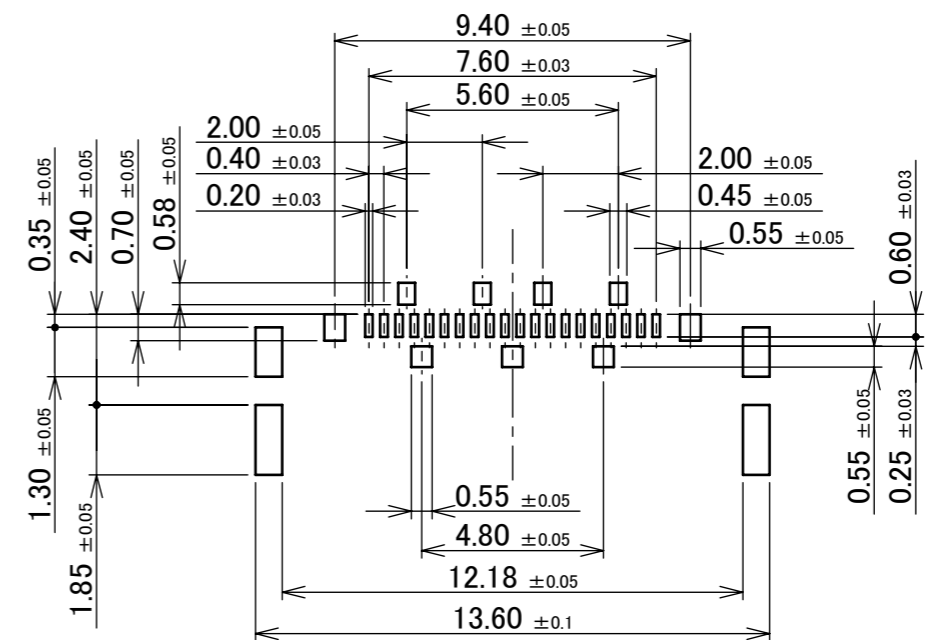

**20P RECOMMENDED METAL MASK LAYOUT  
METAL MASK THICKNESS : t=0.12mm**

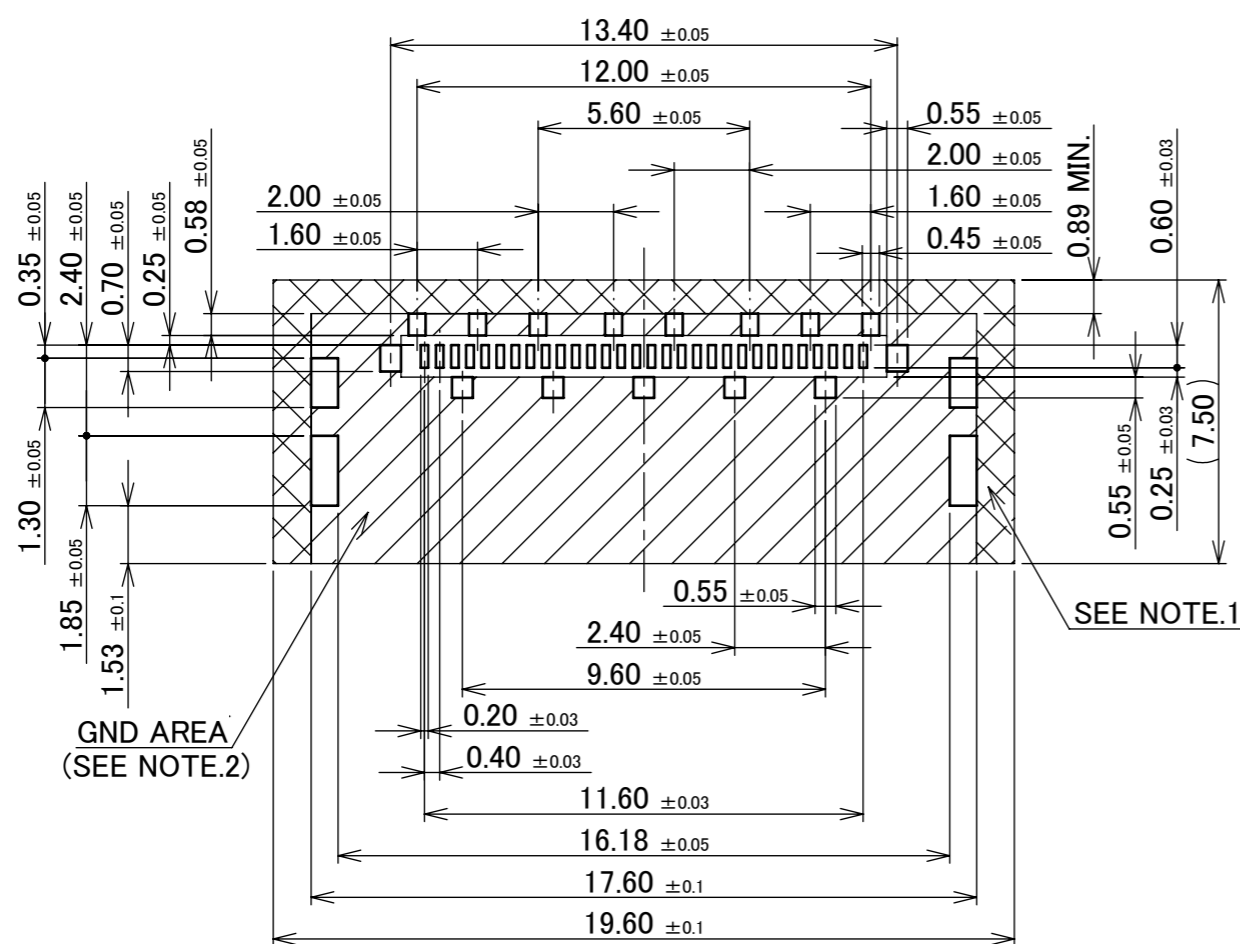

**30P RECOMMENDED FOOTPRINT PATTERN LAYOUT**

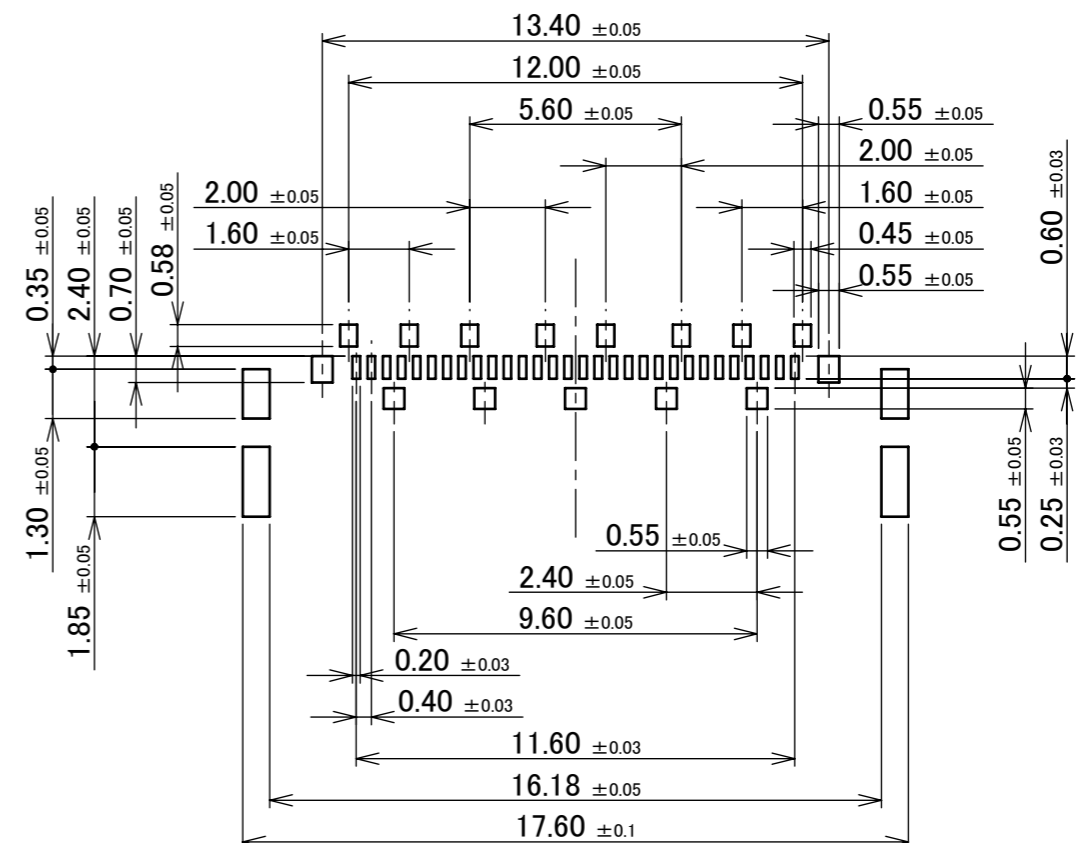

**30P RECOMMENDED METAL MASK LAYOUT  
METAL MASK THICKNESS : t=0.12mm**

NOTES.  
1. THIS AREA CANNOT MOUNT ANOTHER COMPONENTS.  
2. SOLDER RESIST SHALL BE APPLIED TO PREVENT SHORT CIRCUITS WHEN PLACING SIGNAL LINES ON GROUND AREA.

ANGLE	±2°	6 OVER 30 MAX.	±0.3	PROJECTION	SERIES No.	CUSTOMER COPY	
6 MAX.	±0.2	30 OVER 120 MAX.	±0.5		R1		
GENERAL TOLERANCE.				TITLE	SCALE	<b>I-PEX</b>	
DWG.	DATE			CABLINE® -CA II	5:1		
CHK.				RECE. ASS'Y	UNIT		
APP.					mm		
				DWG. No.	SIZE	SHEET	REV.
				20682	A3	4/7	9

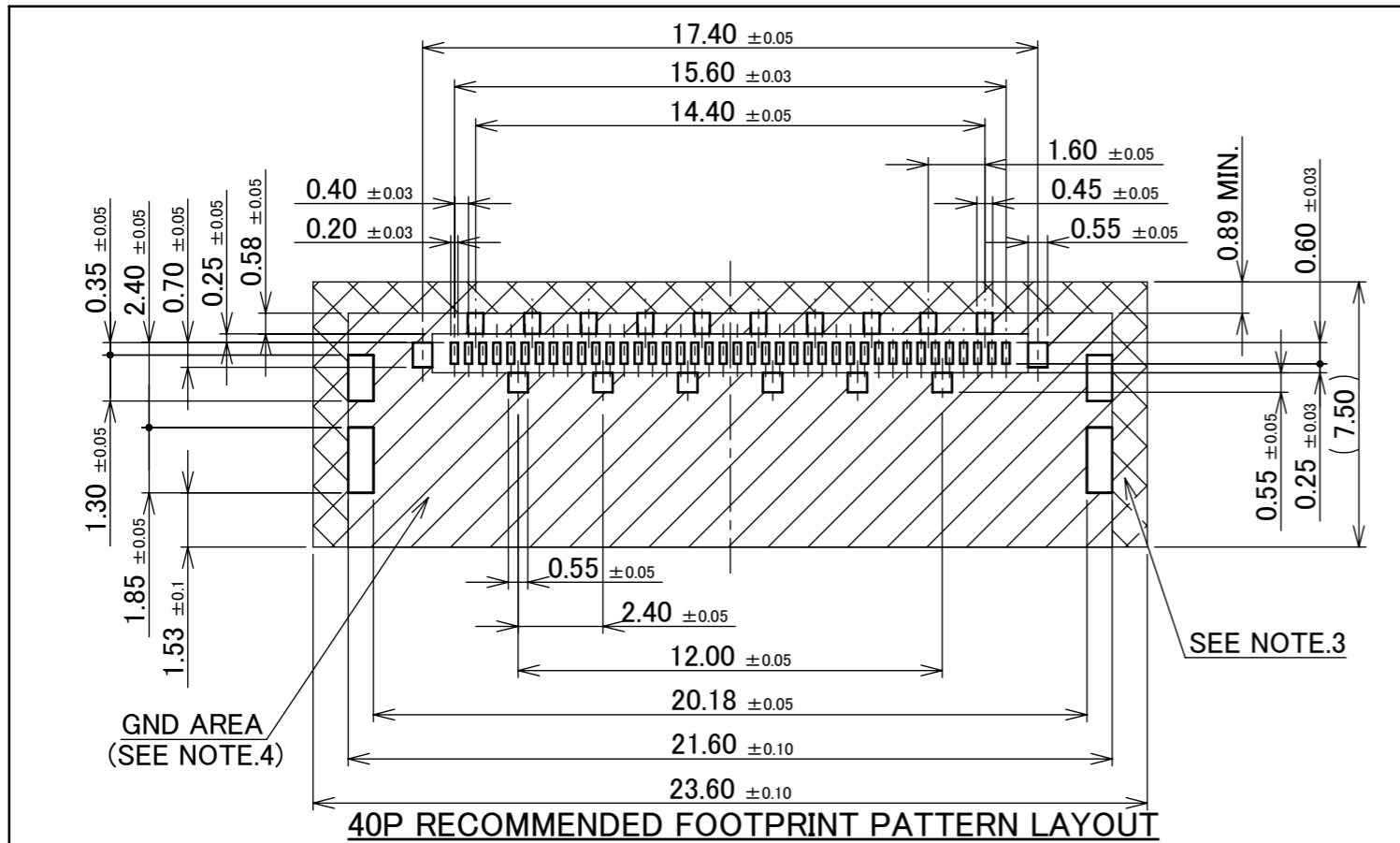

**40P RECOMMENDED FOOTPRINT PATTERN LAYOUT**

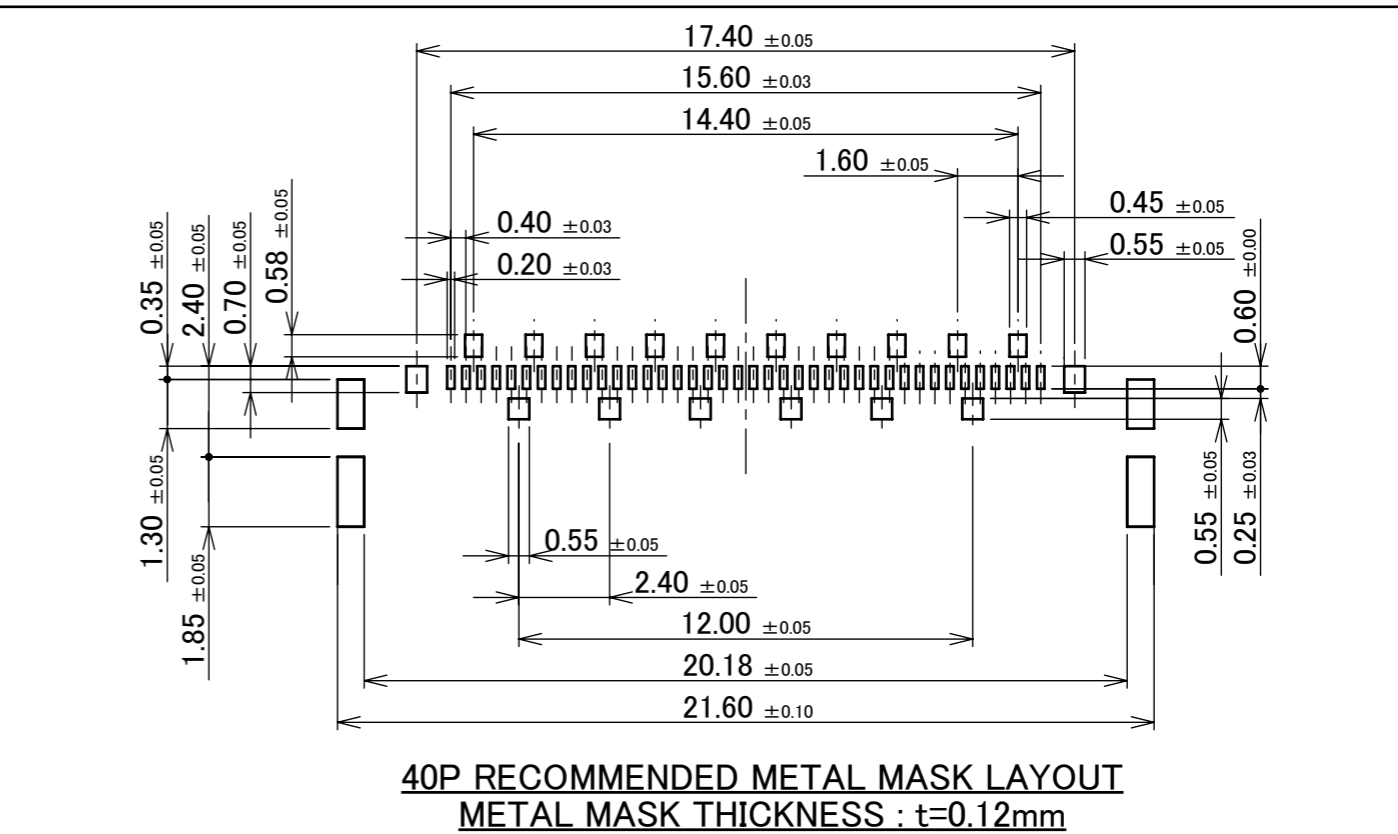

**40P RECOMMENDED METAL MASK LAYOUT  
METAL MASK THICKNESS : t=0.12mm**

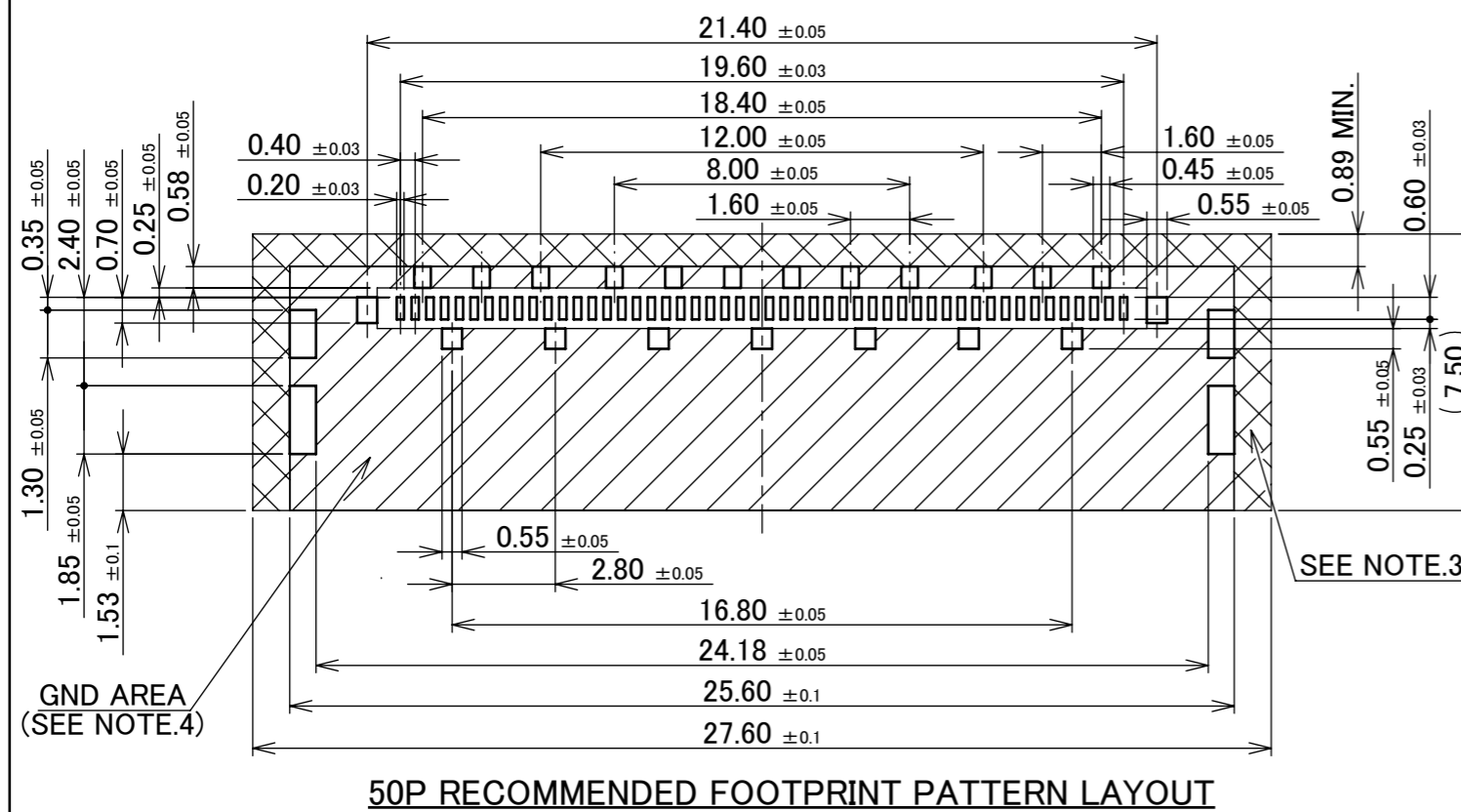

**50P RECOMMENDED FOOTPRINT PATTERN LAYOUT**

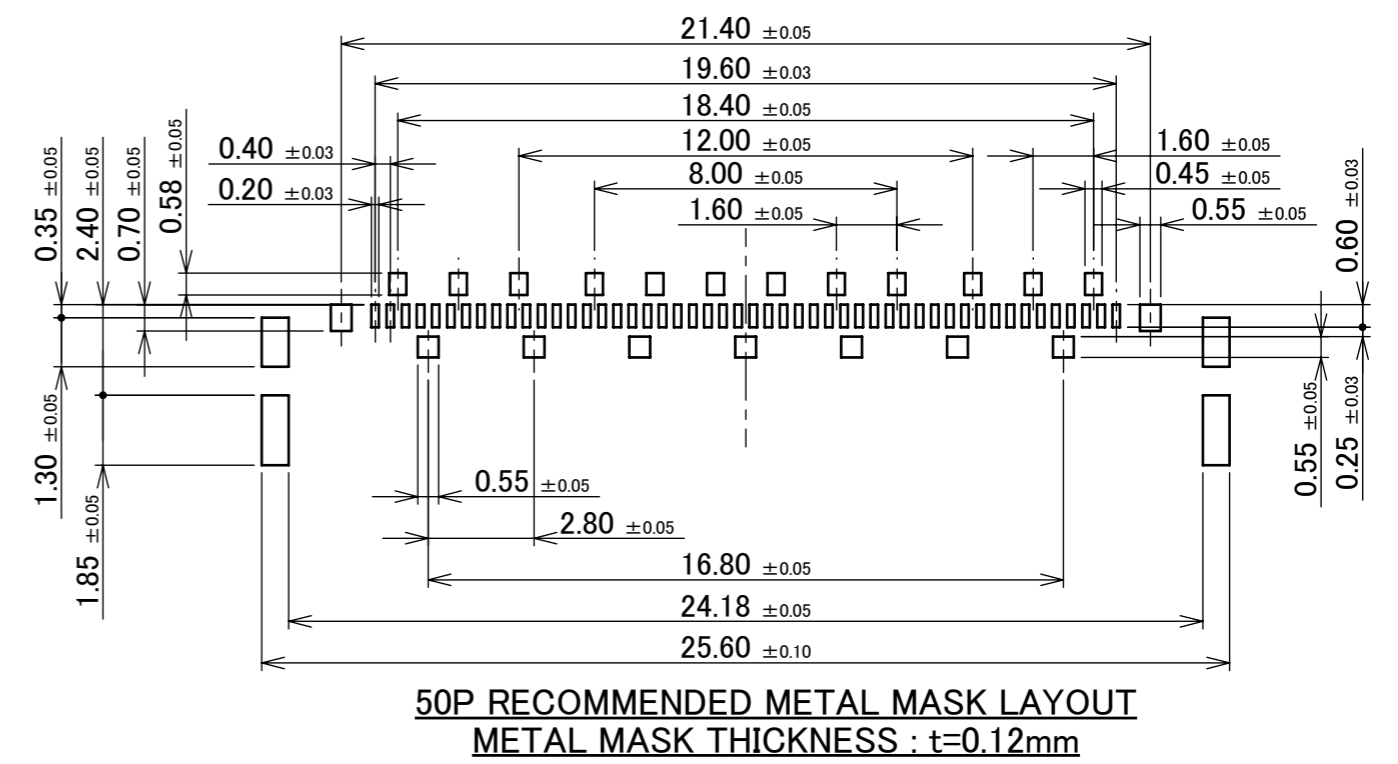

**50P RECOMMENDED METAL MASK LAYOUT  
METAL MASK THICKNESS : t=0.12mm**

**NOTES.**

- 3. THIS AREA CANNOT MOUNT ANOTHER COMPONENTS.
- 4. SOLDER RESIST SHALL BE APPLIED TO PREVENT SHORT CIRCUITS WHEN PLACING SIGNAL LINES ON GROUND AREA.

ANGLE	±2°	6 OVER 30 MAX.	±0.3	PROJECTION ⊕	SERIES No. R1	CUSTOMER COPY	
	6 MAX.	±0.2	30 OVER 120 MAX.				
GENERAL TOLERANCE.				TITLE		SCALE	<b>I-PEX</b>
DWG.	DATE			CABLINE® -CA II		5:1	
CHK.				RECE. ASS'Y		UNIT	
APP.				DWG. No. 20682		mm	
				SIZE		SHEET	REV.
				A3		5/7	9

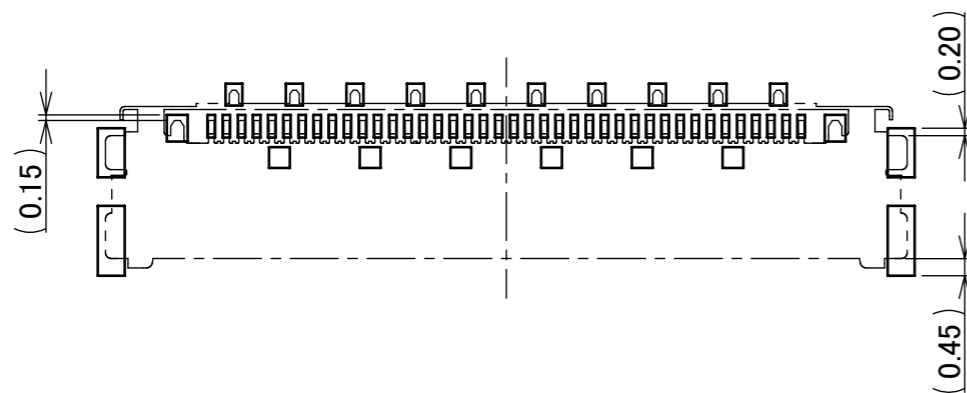

CONNECTOR ON RECOMMENDED FOOTPRINT PATTERN

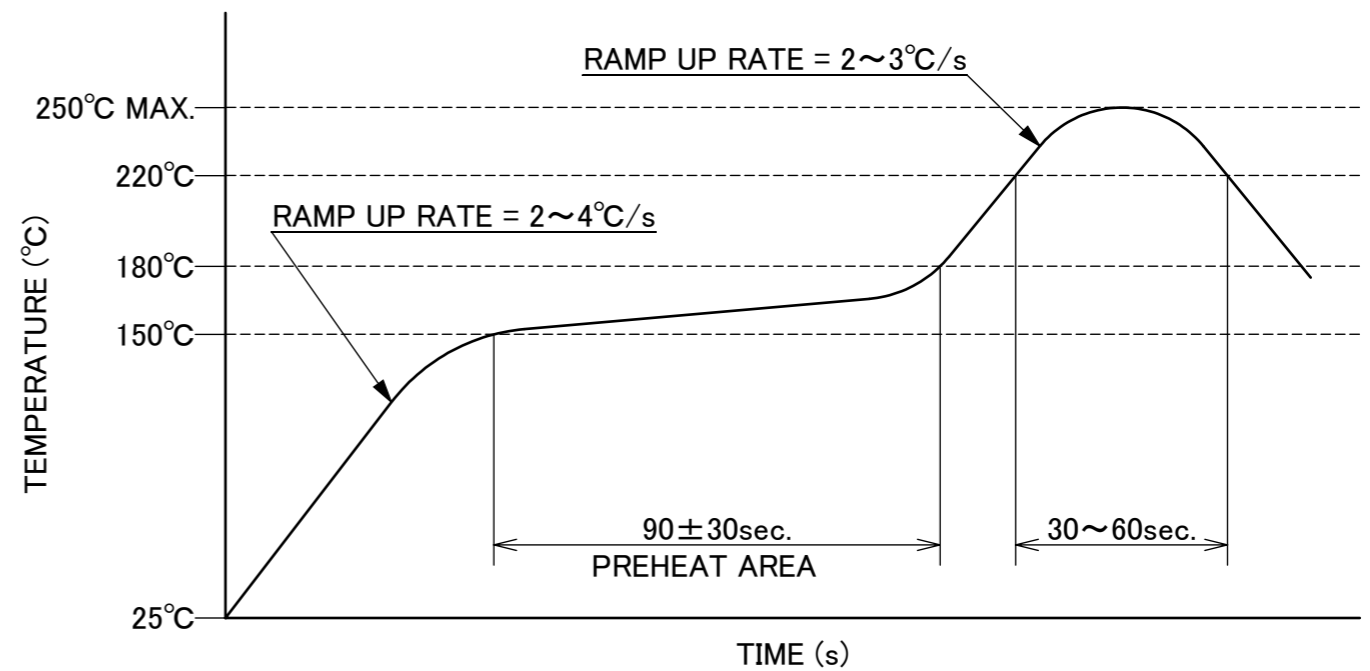

REFLOW TEMPERATURE PROFILE  
SENJU METAL INDUSTRY CO., LTD. : M705-SHF(Sn96.5 Ag3.0 Cu0.5)

ANGLE	±2°	6 OVER 30 MAX.	±0.3	PROJECTION 	SERIES No. R1	CUSTOMER COPY			
6 MAX.	±0.2	30 OVER 120 MAX.	±0.5						
GENERAL TOLERANCE.				TITLE		SCALE			
DWG.	DATE			CABLIN <sup>®</sup> -CA II		5:1			
CHK.				RECE. ASS'Y		UNIT			
APP.				DWG. No. 20682		mm			
				SIZE	SHEET	REV.			
				A3	6/7	9			

PART NO.	G	M	N	P	Q	R	S	T	QTY. PER EMBOSS REEL (PIECES / REEL)	QTY. PER PACKING CARTON (REELS / CARTON)	PART NO.	QTY. PER EMBOSS REEL (PIECES / REEL)	QTY. PER PACKING CARTON (REELS / CARTON)
20682-020E-02	24.00	7.60	9.80	12.00	13.60	11.50	-	24.00	5500 / REEL	5 / CARTON = 27500	20682-020E-02-S	500 / REEL	5 / CARTON = 2500
20682-030E-02	32.00	14.40	13.80	16.00	17.60	14.20	28.40	32.00		4 / CARTON = 22000	20682-030E-02-S		4 / CARTON = 2000
20682-040E-02	32.00	18.40	17.80	20.00	21.60	14.20	28.40	32.00		3 / CARTON = 16500	20682-040E-02-S		3 / CARTON = 1500
20682-050E-02	44.00	22.40	21.80	24.00	25.60	20.20	40.40	44.00			20682-050E-02-S		

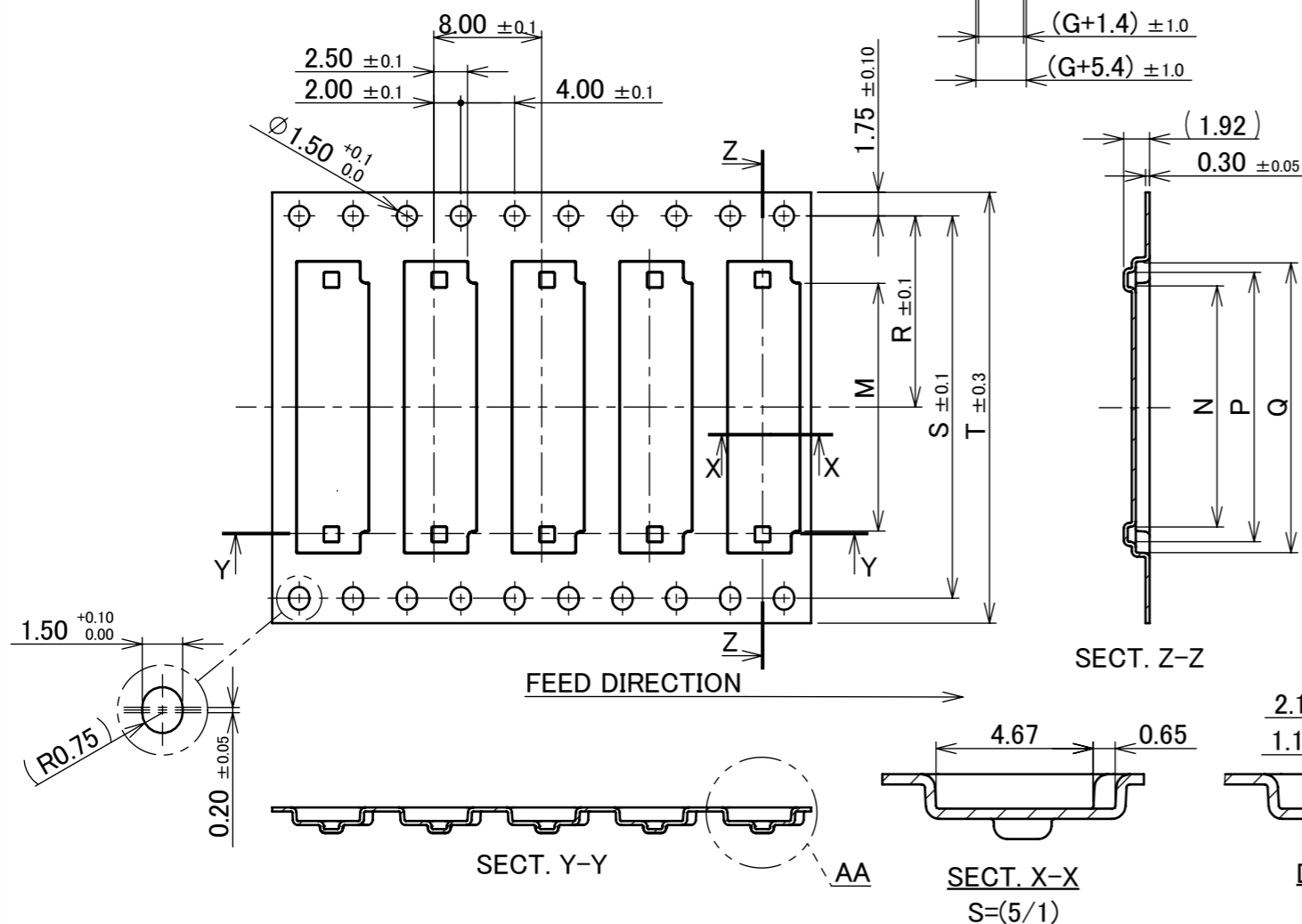
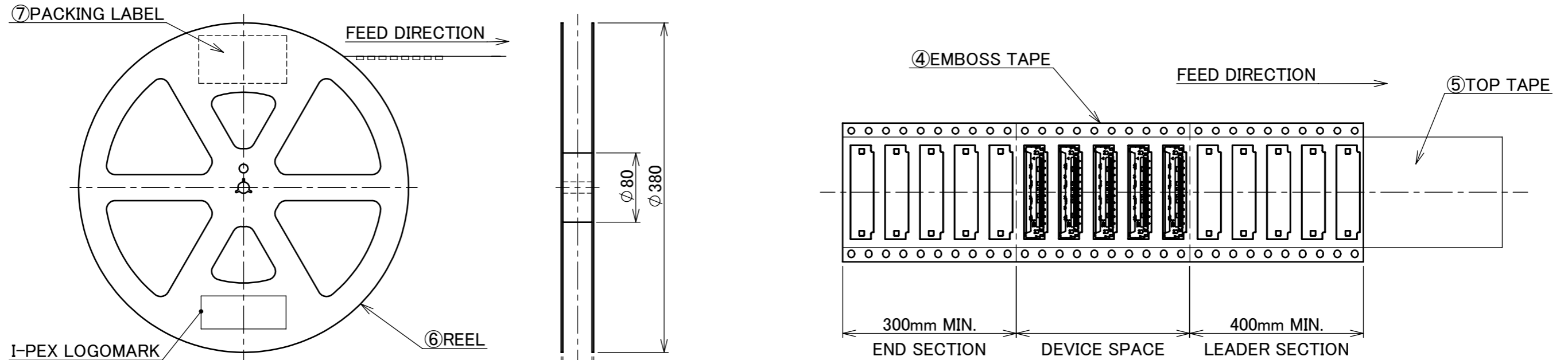

NOTES.

- TAPING SPECIFICATION FOLLOWS JIS C 0806 (IEC 60286-3).
- MAKE EMPTY SECTION OF LEADER AND END ON EACH END OF THE TAPE.
- TOP TAPE SHALL NOT STICK OUT FROM EMBOSS TAPE.
- TOP TAPE SHALL NOT COVER FEED HOLE.

NO.	DISCRIPTION	MATERIAL	FINISH , REMARKS
7	PACKING LABEL	-	-
6	REEL	PS	ANTI-STATIC TYPE BLACK
5	TOP TAPE	PET t=0.062 TRANSPARENCY	ANTI-STATIC TYPE
4	EMBOS TAPE	PS t=0.3 TRANSPARENCY	ANTI-STATIC TYPE

ANGLE	±2°	6 OVER 30 MAX.	±0.3	PROJECTION	SERIES No.	CUSTOMER COPY	
6 MAX.	±0.2	30 OVER 120 MAX.	±0.5		R1		
GENERAL TOLERANCE.				TITLE	SCALE	<b>I-PEX</b>	
DWG.	DATE			CABLIN <sup>®</sup> -CA II RECE. ASS'Y	5:1		
CHK.				DWG. No.	SIZE	SHEET	
APP.				20682	A3	7/7	
						REV.	9