

Recommended P/N

20788-0**T-01

PART NO.	Pos.
20788-060T-01	60



Halogen Free



RoHS Compliant

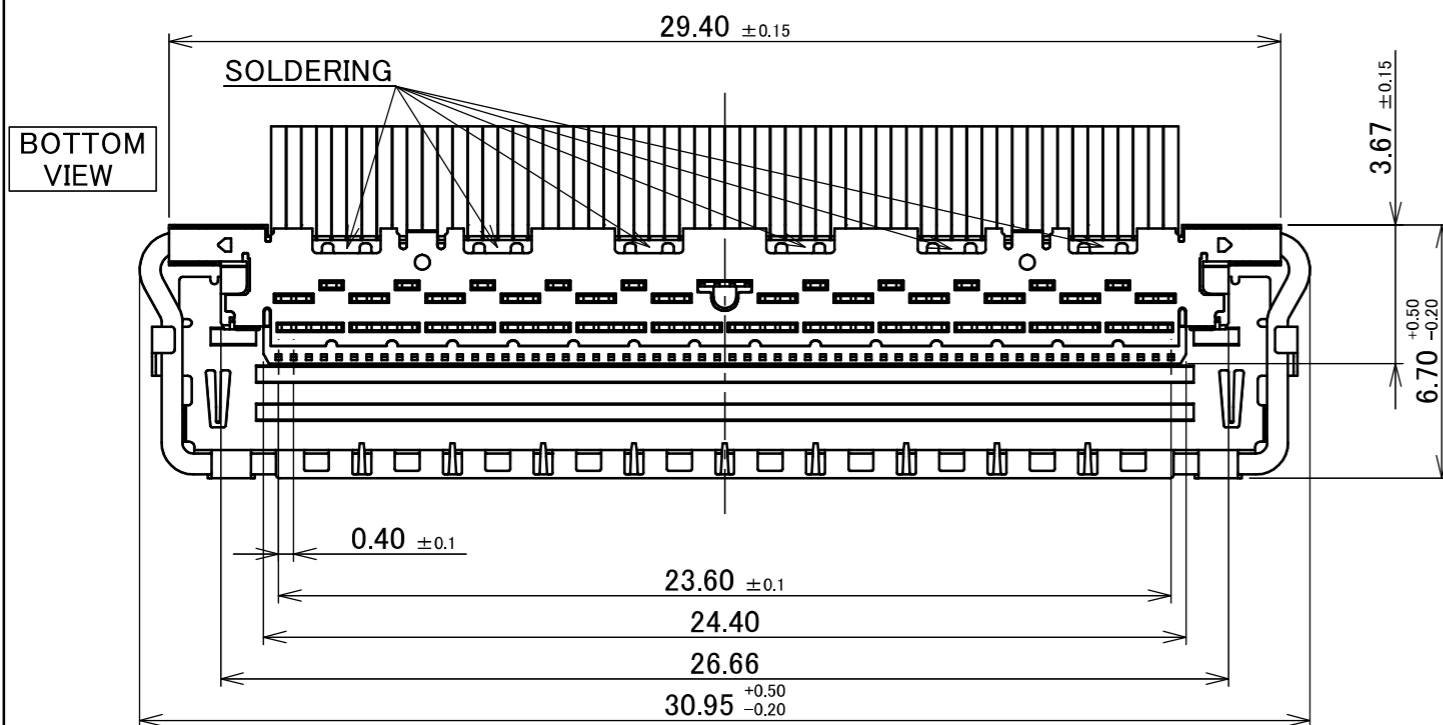

P/N : 20788-0 ** T-0 1
Pos.

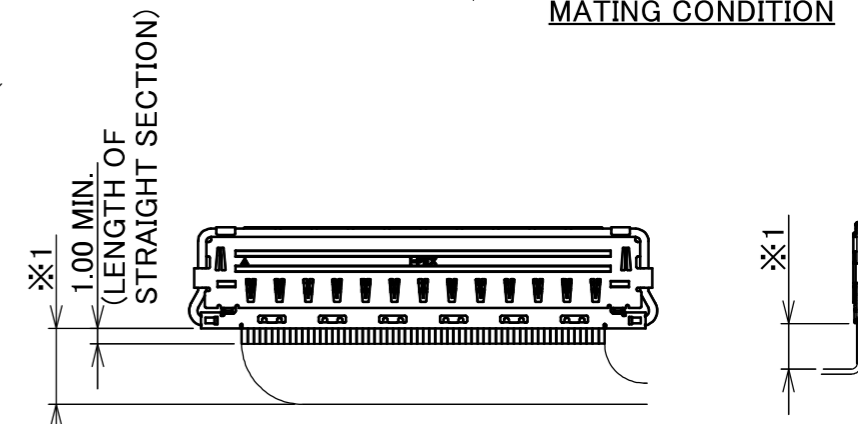
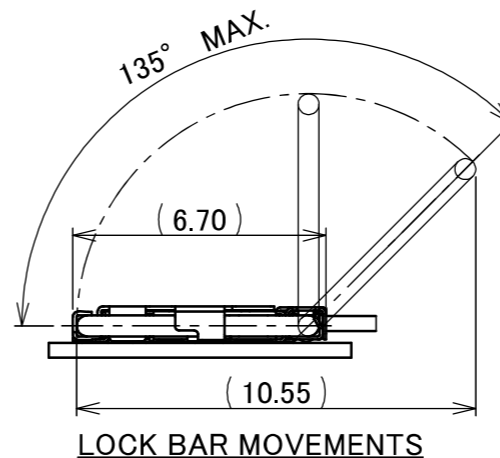
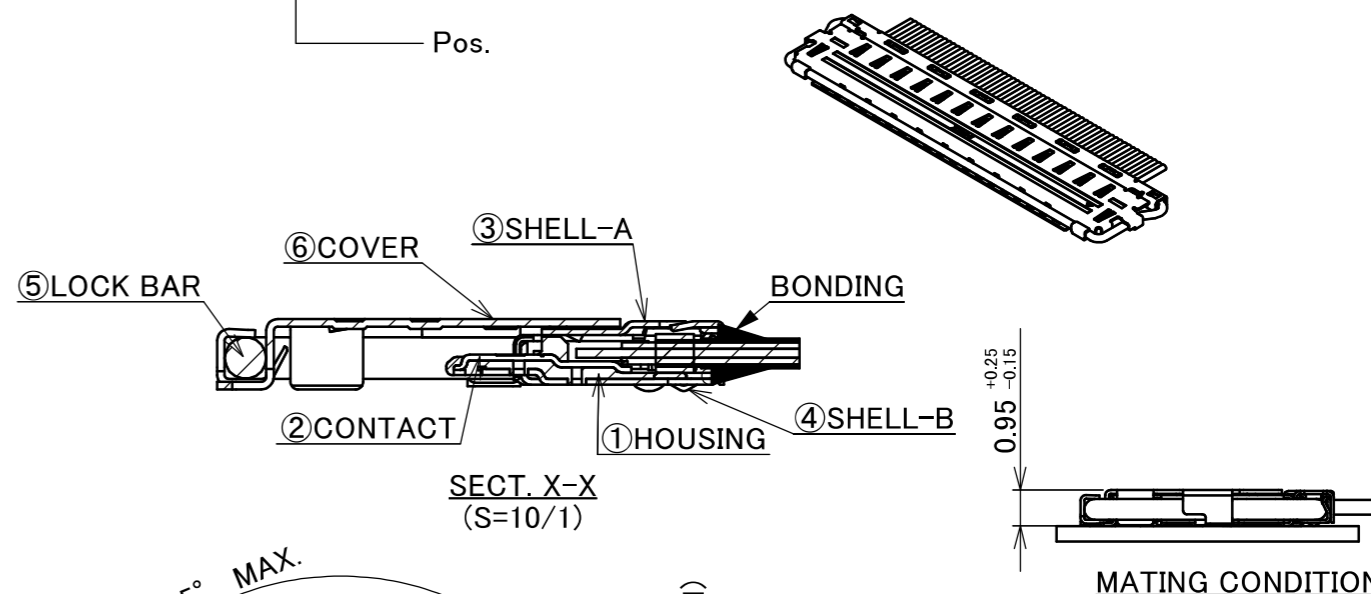

※1 : THE BEND DIMENSIONS MAY VARY BASED ON THE SIZE AND QUANTITY OF CABLES. PLEASE CONFIRM THE MINIMUM BENDING RADIUS WITH I-PEX OR THE HARNESS MANUFACTURER.

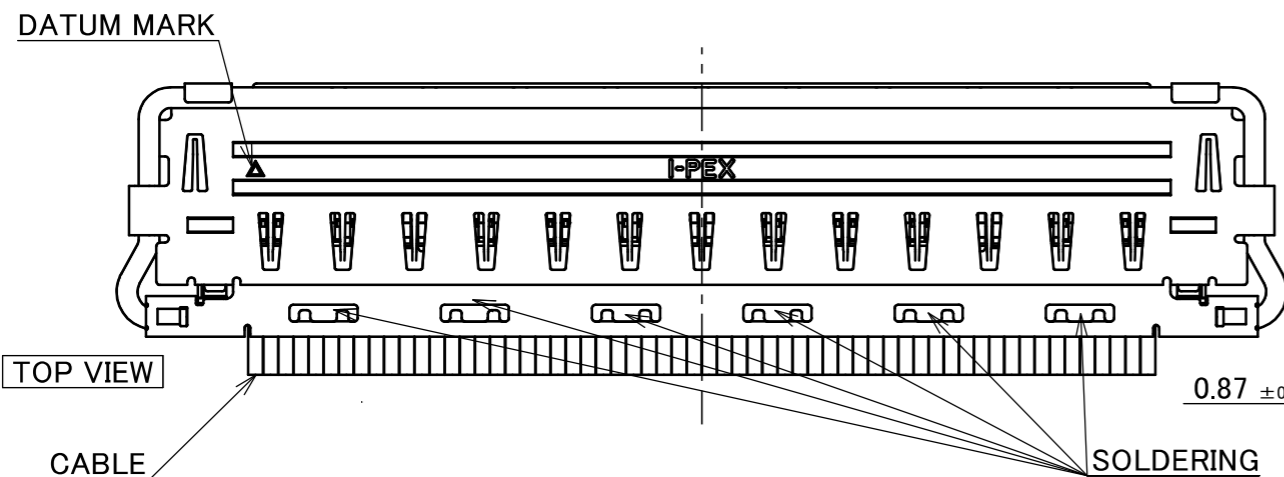

6	COVER	PHOSPHOR BRONZE	ALL OVER Ni 1.00 μm MIN.
5	LOCK BAR	SUS φ0.55	-
4	SHELL-B	PHOSPHOR BRONZE	PARTIAL Au 0.003 μm MIN. OVER Ni 1.00 μm MIN.
3	SHELL-A	PHOSPHOR BRONZE	PARTIAL Au 0.003 μm MIN. OVER Ni 1.00 μm MIN.
2	CONTACT	PHOSPHOR BRONZE	ALL OVER Ni 1.00 μm MIN. CONTACT & SOLDERING AREA : Au 0.03 μm MIN.
1	HOUSING	LCP	UL94V-0 ,BLACK
NO.	DISCRIPTION	MATERIAL	FINISH , REMARKS

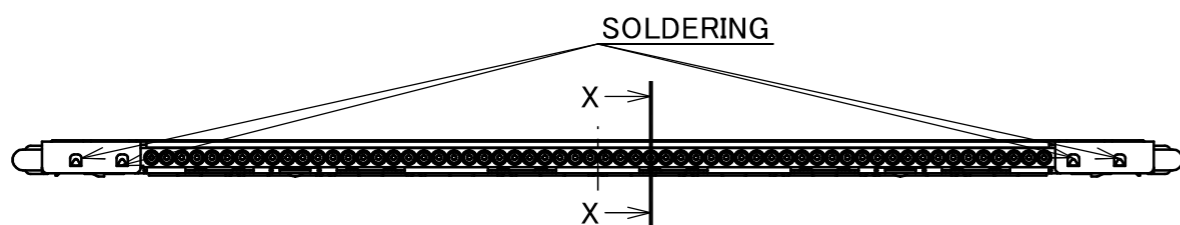

14	Z250426	K.Hara	Mar./13/'25	H.I	ANGLE	±2°	6 OVER 30 MAX.	±0.3	PROJECTION ⊕	SERIES No. R1R2R2	CUSTOMER COPY
13	Z241436	T.T	Oct./16/'24	H.I	6 MAX.	±0.2	30 OVER 120 MAX.	±0.5			
12	Z241307	K.Hara	Sept./24/'24	H.I	GENERAL TOLERANCE.			TITLE CABLINER®-CA II PLUS PLUG FOR CABLE ASSEMBLY	SCALE 5:1	UNIT mm	I-PEX
11	Z240025	K.Hara	Jan./12/'24	H.I	DWG.	DATE					
10	Z230125	K.Hara	Jan./31/'23	H.I	CHK.	T.Masunaga 2016/11/14		DWG. No. 20788	SIZE A3	SHEET 1/3	REV. 14
9	Z230042	K.B	Jan./13/'23	H.I	CHK.	T.Kurachi					
REV.	ECN	BY	DATE	APP.	APP.	J.Tateishi					

PATENT REGISTERED

Confidential C

I-PEX Inc.

QKE-DFE06-02 REV.12

ITEMS	SPECIFICATION
APPLICABLE CABLE	MICRO-COAXIAL CABLE : AWG# 44 , 42 , 40 , 38 , 36 DISCRETE WIRE : AWG# 36 , 34 TWINAX CABLE : AWG# 40 , 42
RATING VOLTAGE	100V AC (PER CONTACT PIN) ※THIS IS THE RATED VOLTAGE OF THE CONNECTOR. PLEASE NOTE THAT THE RATED VOLTAGE MAY VARY IN THE HARNESS DEPENDING ON THE CABLES USED.
RATING AMPERAGE (FOR CONTACT)	0.1A AC/DC [AWG#44] PER CONTACT PIN / UP TO 60 CONTACTS 0.24A AC/DC [AWG#42] PER CONTACT PIN / UP TO 60 CONTACTS 0.3A AC/DC [AWG#40] PER CONTACT PIN / UP TO 60 CONTACTS 0.5A AC/DC [AWG#38] PER CONTACT PIN / UP TO 18 CONTACTS 0.8A AC/DC [AWG#36] PER CONTACT PIN / UP TO 6 CONTACTS 1.0A AC/DC [AWG#34] PER CONTACT PIN / UP TO 6 CONTACTS ※TESTING BY REAL MACHINE IS RECOMMENDED BECAUSE TEMPERATURE RISE MAY AFFECTED BY ACTUAL SITUATION
OPERATING TEMPERATURE	248~378K(-40°C~105°C)
OPERATING HUMIDITY	85% MAX.(NON-CONDENDING)
CONTACT RESISTANCE	INITIAL : 180mohm MAX.(AWG#34) / AFTER TEST : \triangle 40mohm MAX. 275mohm MAX.(AWG#36) 360mohm MAX.(AWG#38) 600mohm MAX.(AWG#40) 700mohm MAX.(AWG#42) 1080mohm MAX.(AWG#44)
GROUND SHELL RESISTANCE	INITIAL : 50mohm MAX. / AFTER TEST : \triangle 40mohm MAX.
INSULATION RESISTANCE	INITIAL : 1000Mohm MIN. / AFTER TEST : 500Mohm MIN.
DIELECTRIC WITHSTANDING VOLTAGE	AC250V 1min
DURABILITY	30 CYCLES
MATING FORCE (INITIAL / AFTER 30 CYCLES)	29.10N MAX.
UN-MATING FORCE (INITIAL / AFTER 30 CYCLES)	6.0N MIN.
CABLE RETENTION FORCE	29.40N MIN.
PRODUCT SPECIFICATION	PRS-2261
TEST REPORT	TR-16075, TR-23031
INSTRUCTION MANUAL	HIM-16028
ASSEMBLY MANUAL	ASM-16004
APPEARANCE CRITERIA NO.	QLS-A***

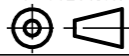
ANGLE	$\pm 2^\circ$	6 OVER 30 MAX.	± 0.3	PROJECTION 	SERIES No. R1R2R2	CUSTOMER COPY						
	6 MAX.	± 0.2	30 OVER 120 MAX.			± 0.5	SCALE	I-PEX				
GENERAL TOLERANCE.				TITLE	UNIT							
DWG.	DATE			CABLIN [®] -CA II PLUS PLUG FOR CABLE ASSEMBLY		mm						
CHK.				DWG. No.	20788	SIZE	SHEET				REV.	
APP.						A3	2/3	14				

PART NO.	Pos.
20788-060T-01	60

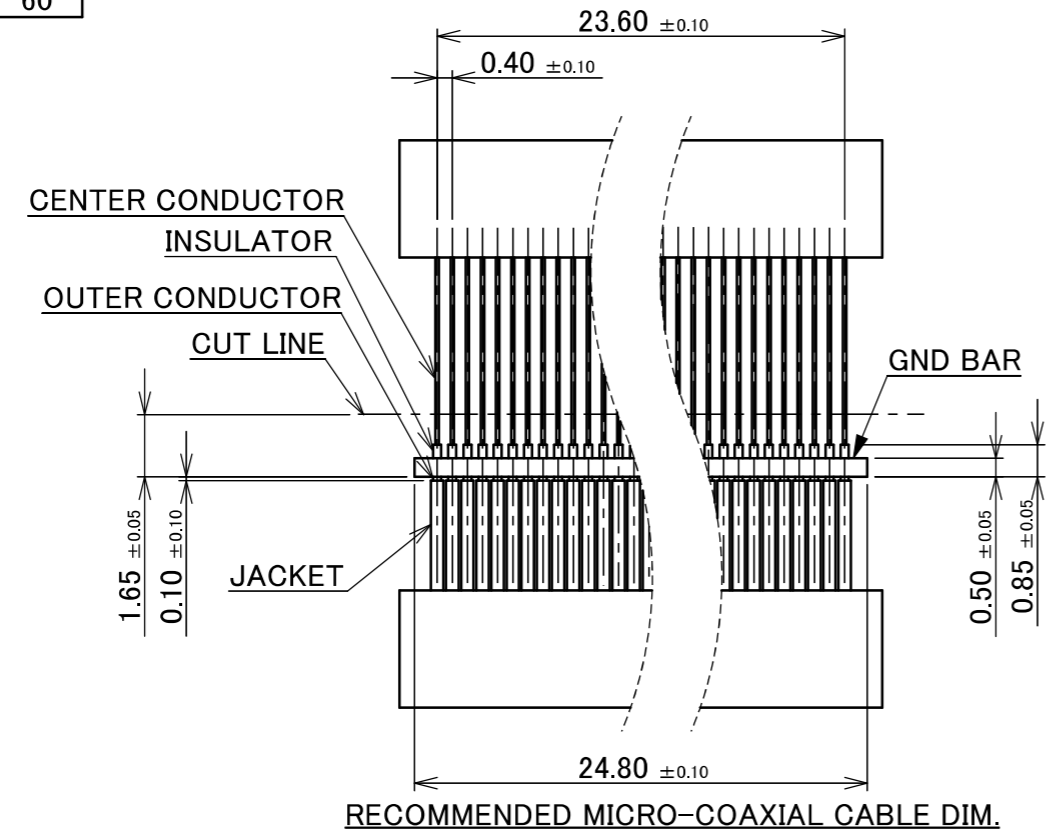

RECOMMENDED MICRO-COAXIAL CABLE DIM.

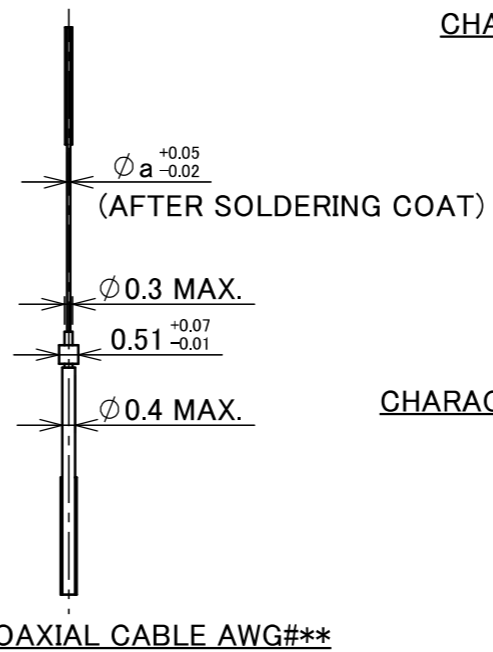

CHARACTERISTIC IMPEDANCE MATCHING MICRO-COAXIAL CABLE

	a
#38	0.12
#40	0.09
#42	0.075
#44	0.063

CHARACTERISTIC IMPEDANCE UN-MATCHING MICRO-COAXIAL CABLE

	a
#36	0.15

MICRO-COAXIAL CABLE #36 : NOT RECOMMENDED FOR HIGH SPEED SIGNAL TRANSFER

MICRO-COAXIAL CABLE AWG#**

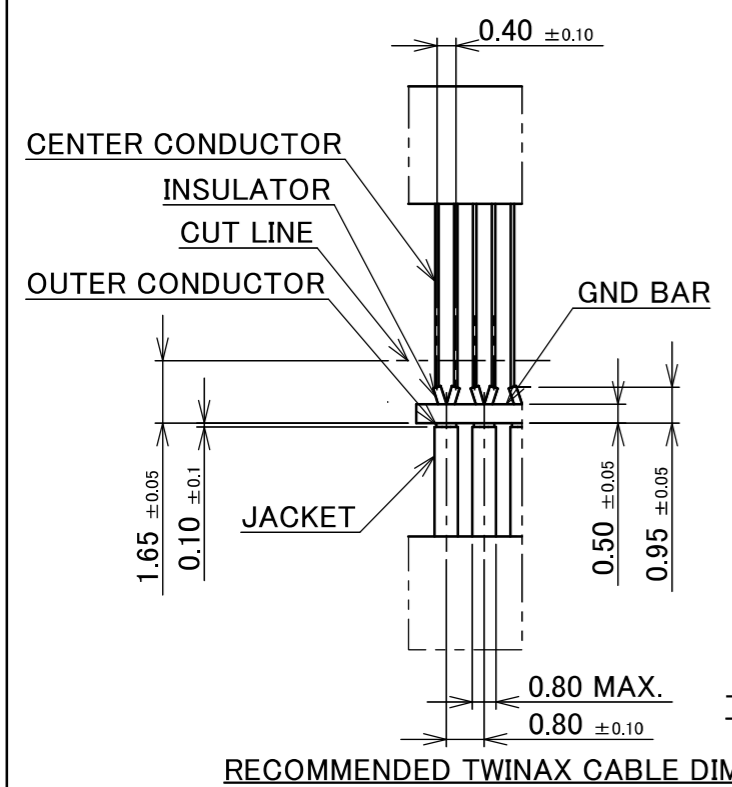

RECOMMENDED TWINAX CABLE DIM.

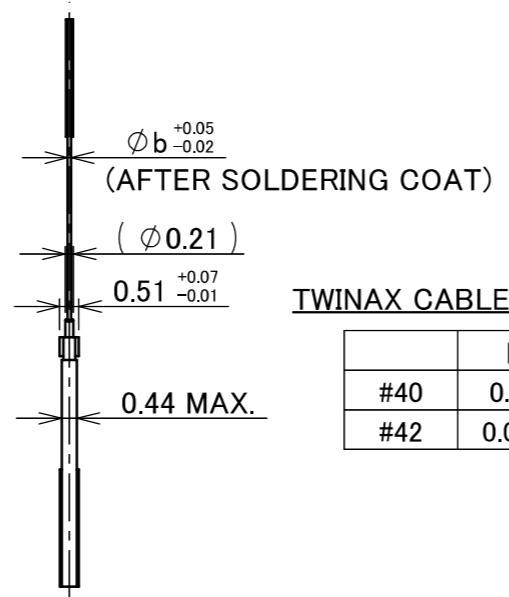

TWINAX CABLE DIMENSION

	b
#40	0.09
#42	0.075

TWINAX CABLE AWG#**

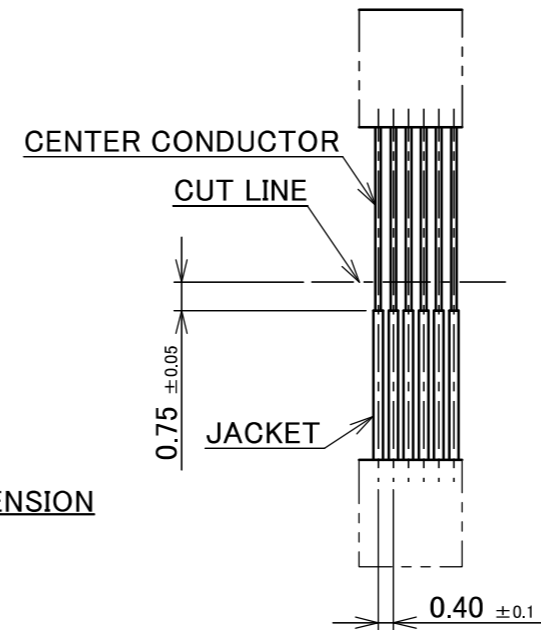

RECOMMENDED DISCRETE WIRE DIM.

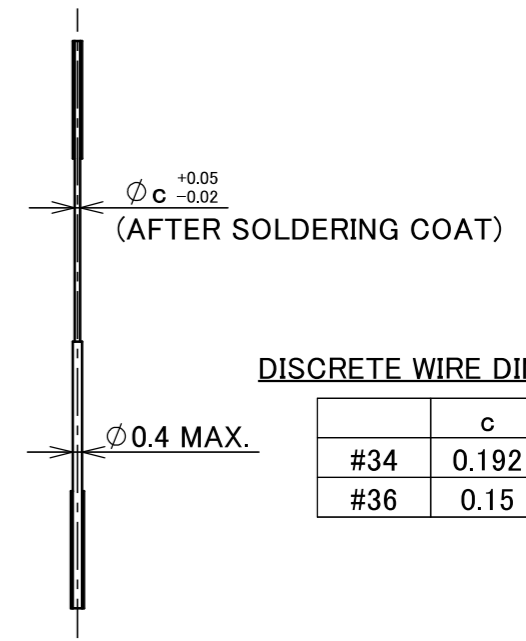

DISCRETE WIRE DIMENSION

	c
#34	0.192
#36	0.15

DISCRETE WIRE AWG#**

ANGLE	±2°	6 OVER 30 MAX.	±0.3	PROJECTION ⊕	SERIES No. R1R2R2	CUSTOMER COPY			
	6 MAX.	±0.2	30 OVER 120 MAX.						±0.5
GENERAL TOLERANCE.				TITLE		SCALE	I-PEX		
DWG.	DATE			CABLIN [®] -CA II PLUS PLUG FOR CABLE ASSEMBLY		5:1			
CHK.						UNIT			
APP.						mm			
				DWG. No.	20788	SIZE	SHEET	REV.	
						A3	3/3	14	