

Recommended P/N

3298-0**1

PART No.	Pos.	A	B	C
3298-0301	30	18.60	12.98	15.86
3298-0401	40	22.60	16.98	19.86

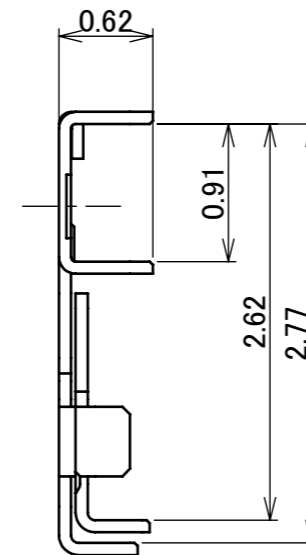
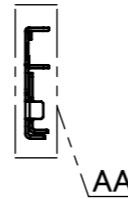
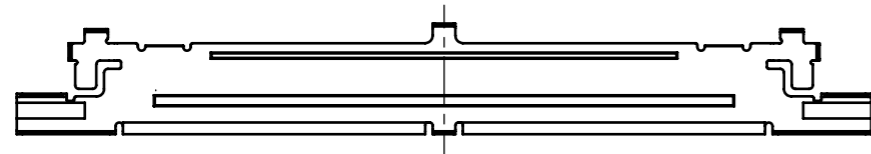
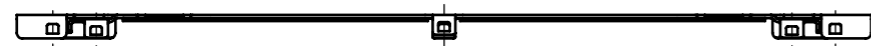
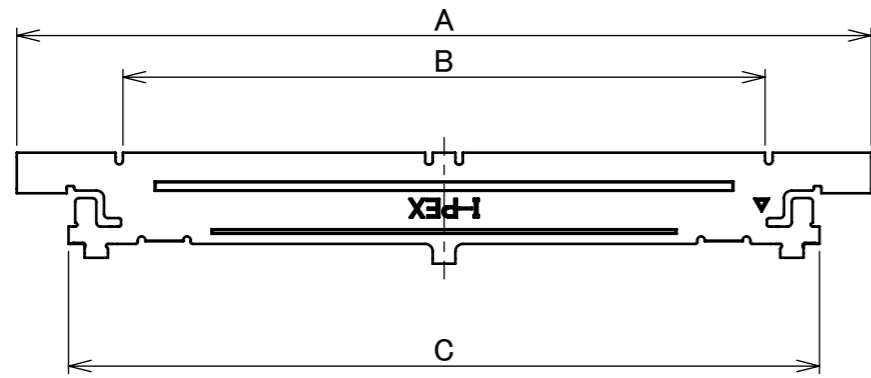
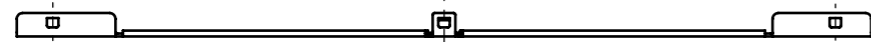
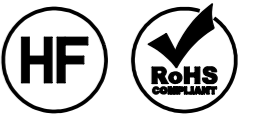

DETAIL AA
(S=20/1)

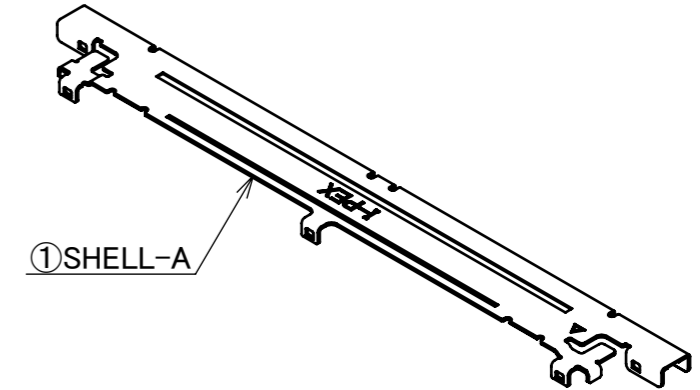

NO.	DISCRIPTION	MATERIAL	FINISH , REMARKS
1	SHELL-A	PHOSPHOR BRONZE	PARTIAL Au 0.003 μ m MIN. OVER Ni 1.0 μ m MIN.

REV.	ECN	BY	DATE	APP.	APP.	DATE	DWG. No.	SIZE	SHEET	REV.
3	Z191189	S.Y	Sept./06/'19	H.I			3298	A3	1/2	3
2	Z181287	M.I	Oct./01/'18	H.I						
1	Z180190	M.I	Feb./14/'18	H.I						
0	Z170418	M.I	Apr./12/'17							

PART No.	Pos.	D	E	QTY. PER REEL (PIECES / REEL)	QTY. PER REEL (REELS / CARTON)	PACKING STANDARD
3298-0301	30	27.00	30.00	8000 / REEL	3 / CARTON =24000	PST-17056
3298-0401	40	32.00	35.00			

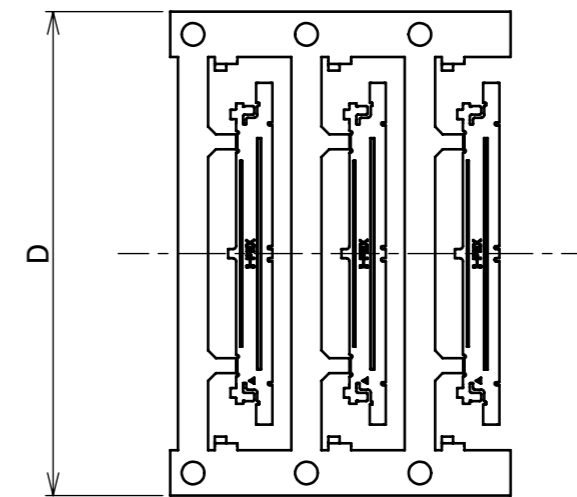
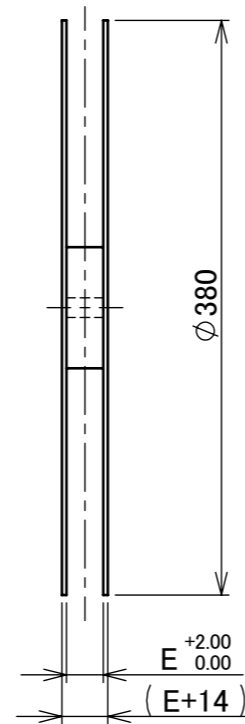
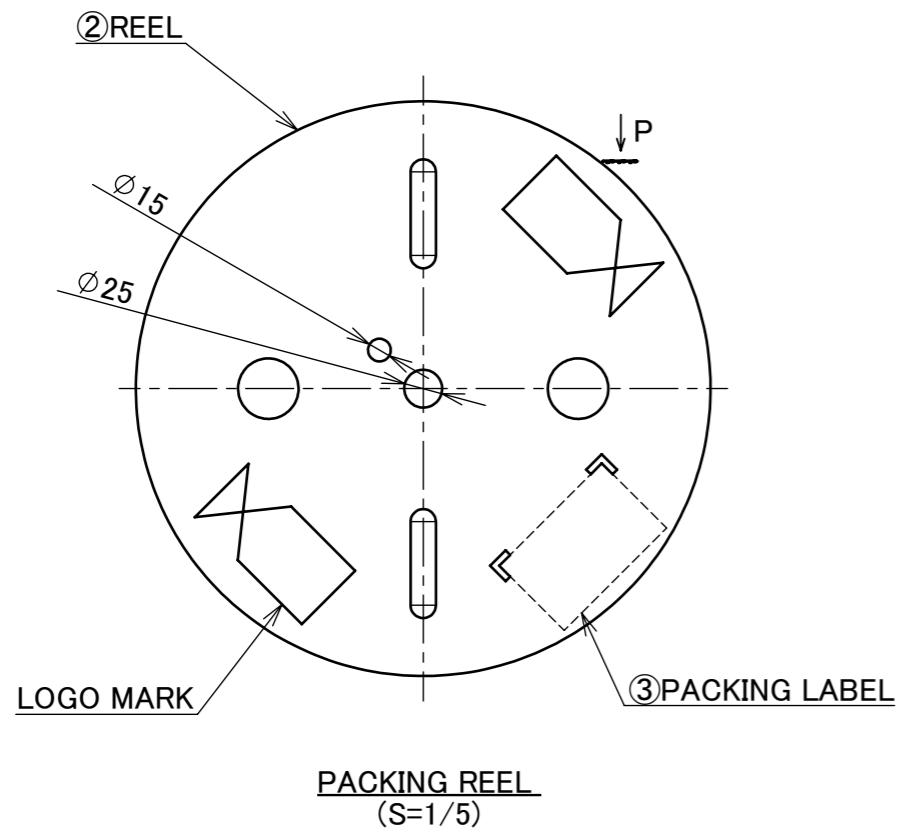

VIEW P
(S=2/1)

NO.	DISCRIPTION	MATERIAL	FINISH , REMARKS
3	PACKING LABEL	-	-
2	PACKING REEL	CARD BOARD	-

ANGLE	$\pm 2^\circ$	6 OVER 30 MAX.	± 0.3	PROJECTION 	SERIES No. R1	CUSTOMER COPY
6 MAX.	± 0.2	30 OVER 120 MAX.	± 0.5			
GENERAL TOLERANCE.				TITLE CABLIN [®] -CAL PLUG SHELL-A	SCALE 1:X	UNIT mm
DWG.	DATE		DWG. No. 3298			
CHK.	DATE					
APP.	DATE					
				SIZE A3	SHEET 2/2	REV. 3