

Recommended P/N 20777-0**T-01

| PART No. | Pos. | A | B | C | D | E | F | G | H | J |
|---------------|------|------|-------|-------|-------|-------|-------|------|-------|-------|
| 20777-030T-01 | 30 | 4.40 | 8.80 | 18.60 | 14.30 | 13.85 | 13.50 | 5.60 | 12.80 | 13.60 |
| 20777-040T-01 | 40 | 8.40 | 12.80 | 22.60 | 18.30 | 17.85 | 17.50 | 7.60 | 16.80 | 17.60 |

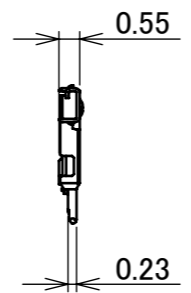
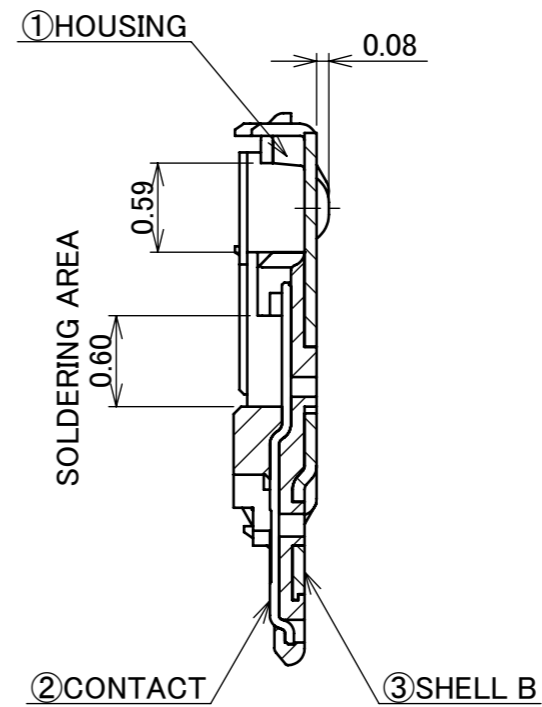
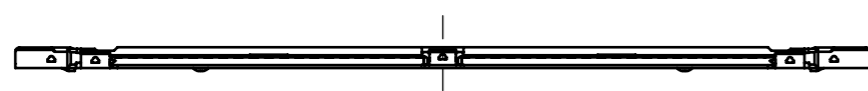
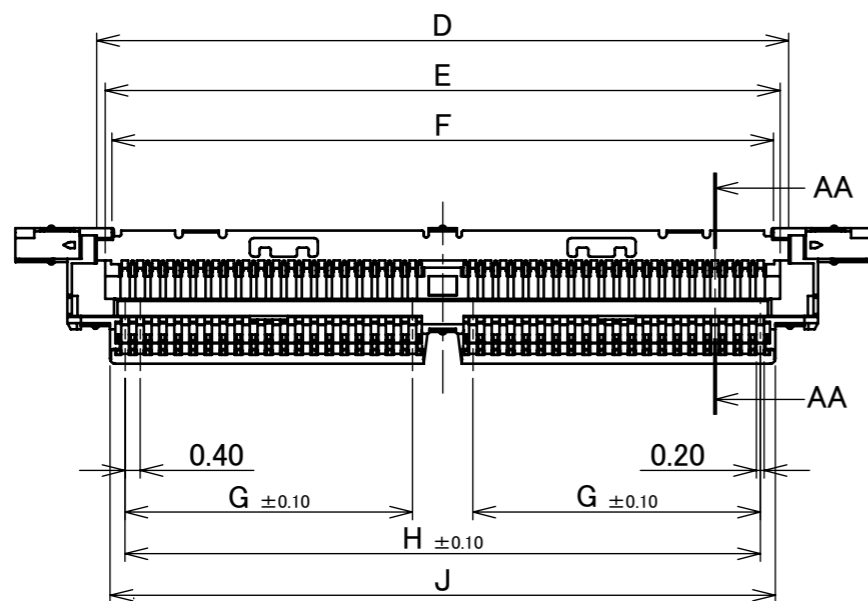
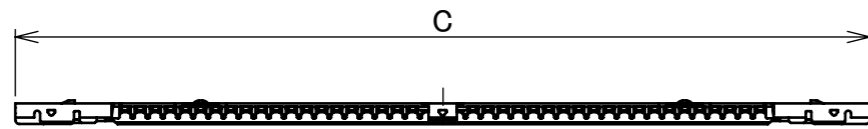
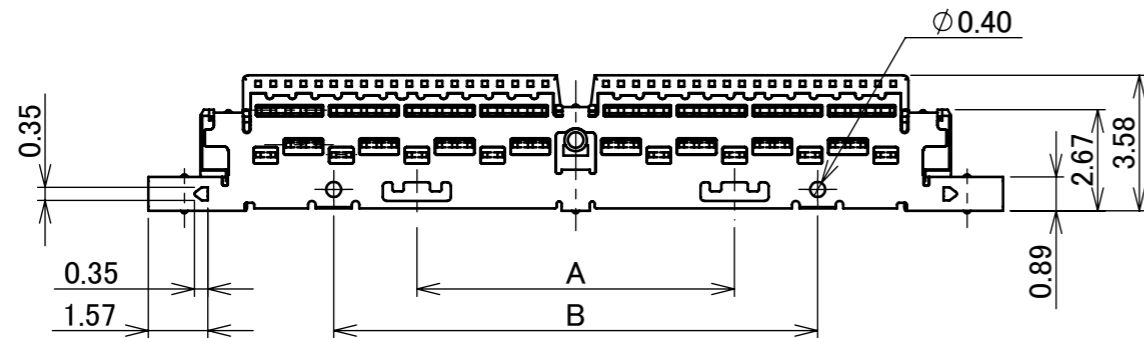
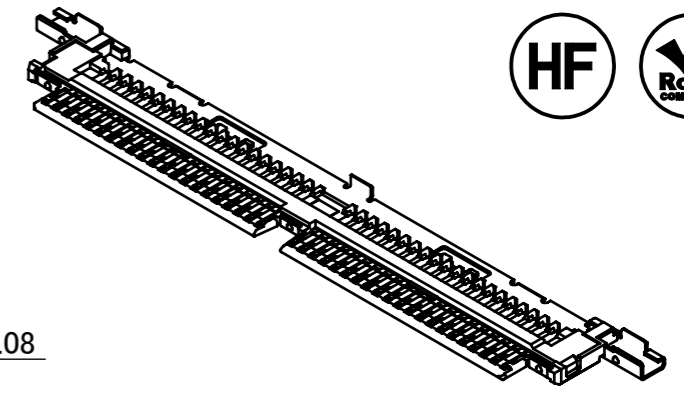
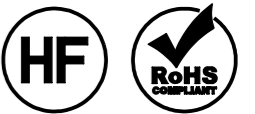

SECT. X-X
(S=15/1)

NOTES.
1. THIS PART IS ASSEMBLED WITH P/N: 3298-0**1 AND 3300-**1 AFTER SOLDERING CABLES AND SHALL BE ASSIGNED AS P/N: 20728-0**T-01.

| NO. | DISCRIPTION | MATERIAL | FINISH , REMARKS |
|-----|-------------|-----------------|--|
| 3 | SHELL-B | PHOSPHOR BRONZE | PARTIAL Au 0.003 μ m MIN. OVER 1.00 μ m MIN. |
| 2 | CONTACT | PHOSPHOR BRONZE | ALL OVER Ni 1.00 μ M MIN. CONTACT & SOLDERING AREA : Au 0.03 μ m MIN. |
| 1 | HOUSING | LCP | UL94-0, BLACK, RED PHOSPHORUS FREE |

| REV. | ECN | BY | DATE | APP. | APP. | ANGLE | PROJECTION | SERIES No. | TITLE | SCALE | CUSTOMER COPY | |
|-----------------|---------|-----|------------|------|-----------------------|-------------------------|------------|------------|--|-------|---------------|------|
| 4 | Z201253 | S.Y | 2020/12/07 | Y.S | 6 MAX. | ±2° 6 OVER 30 MAX. ±0.3 | ⊕ | R3 | CABLINER [®] -CAL PLUG HOUSING ASS'Y | 5:1 | I-PEX | |
| 3 | Z191189 | S.Y | 2019/09/06 | H.I | 30 OVER 120 MAX. ±0.5 | GENERAL TOLERANCE. | | | | mm | | |
| 2 | Z181287 | M.I | 2018/08/01 | H.I | DWG. | DATE | | | | | | |
| 1 | Z180190 | M.I | 2018/02/14 | H.I | M.Ishimaru | 2017/04/12 | | | | | | |
| 0 | Z170418 | M.I | 2017/04/12 | | CHK. | | | | | | | |
| REV. | ECN | BY | DATE | APP. | APP. | | DWG. No. | 20777 | | SIZE | SHEET | REV. |
| REVISION RECORD | | | | | | H.Ikari | | | | A3 | 1/2 | 4 |

| PART NO. | QTY. IN DITCH (PIECES / DITCH) | QTY. IN TRAY (PIECES / TRAY) | QTY. IN SHIPPING CARTON (TRAY / S CARTON) | QTY. PER PACKING CARTON (S CARTON / P CARTON) | PACKING STANDARD |
|---------------|-----------------------------------|---------------------------------|--|--|------------------|
| 20777-030T-01 | 1 | 100 / TRAY | 20 / S CARTON = 2000 | 4 / P CARTON = 8000 | PST-17055 |
| 20777-040T-01 | | | | | |

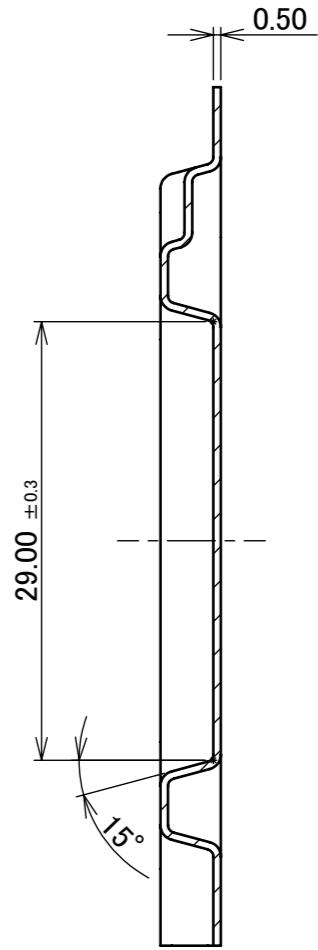
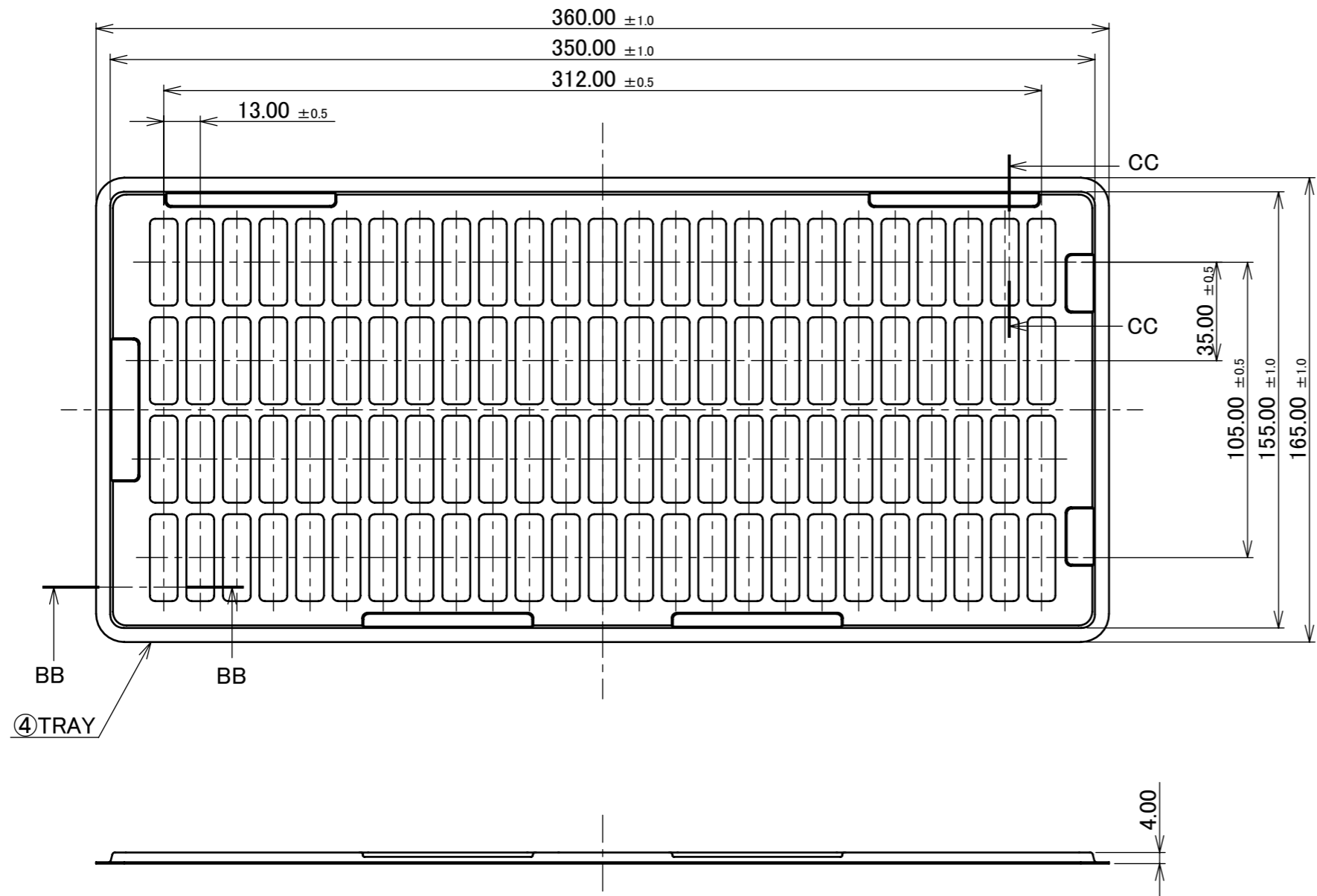

SECT. CC-CC
(S=2/1)

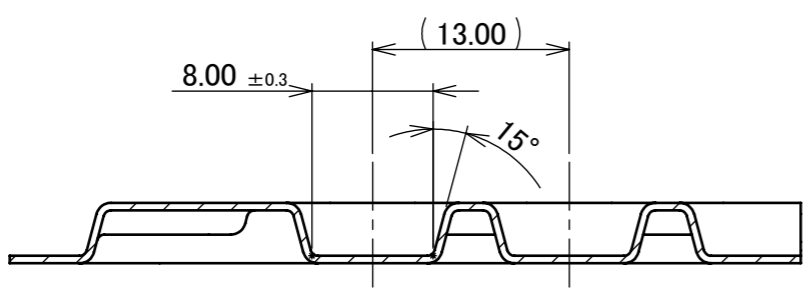

SECT. BB-BB
(S=2/1)

| NO. | DISCRIPTION | MATERIAL | FINISH , REMARKS |
|-----|-------------|----------|------------------|
| 4 | TRAY | PP | ANTI-STATIC TYPE |

| | | | | | | | | |
|--------------------|------|------------------|------|--|------------------|---------------|-------|------|
| ANGLE | ±2° | 6 OVER 30 MAX. | ±0.3 | PROJECTION ⊕ | SERIES No. R3 | CUSTOMER COPY | | |
| 6 MAX. | ±0.2 | 30 OVER 120 MAX. | ±0.5 | | | | | |
| GENERAL TOLERANCE. | | | | TITLE | SCALE | I-PEX | | |
| DWG. | DATE | | | CABLIN [®] -CAL PLUG HOUSING ASS'Y | 1:2 | | | |
| CHK. | | | | | UNIT | | | |
| APP. | | | | | mm | | | |
| | | | | DWG. No. | 20777 | SIZE | SHEET | REV. |
| | | | | | | A3 | 2/2 | 4 |