

Recommended P/N 3532-0001-00T

PART NO.
3532-0001-00T

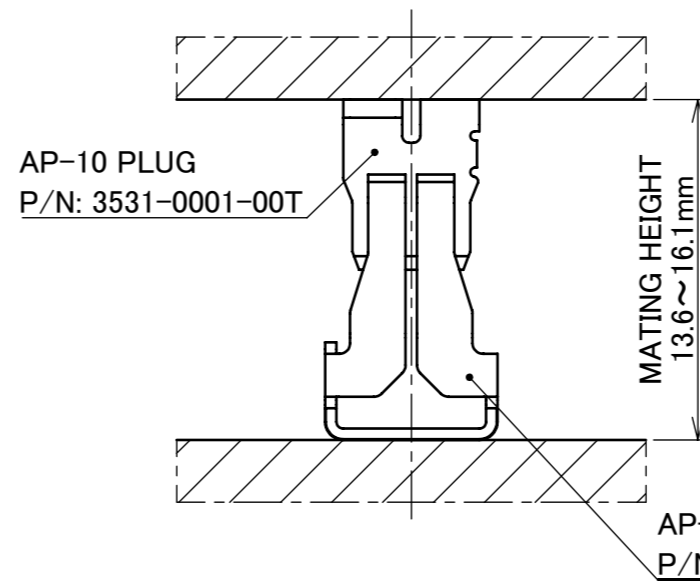

MATING CONDITION
【AP-10 PLUG H=7.5 mm】

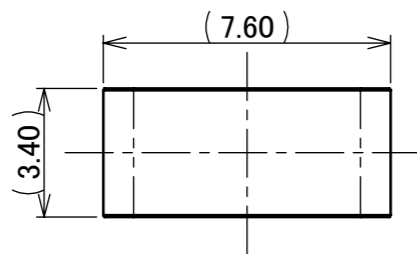
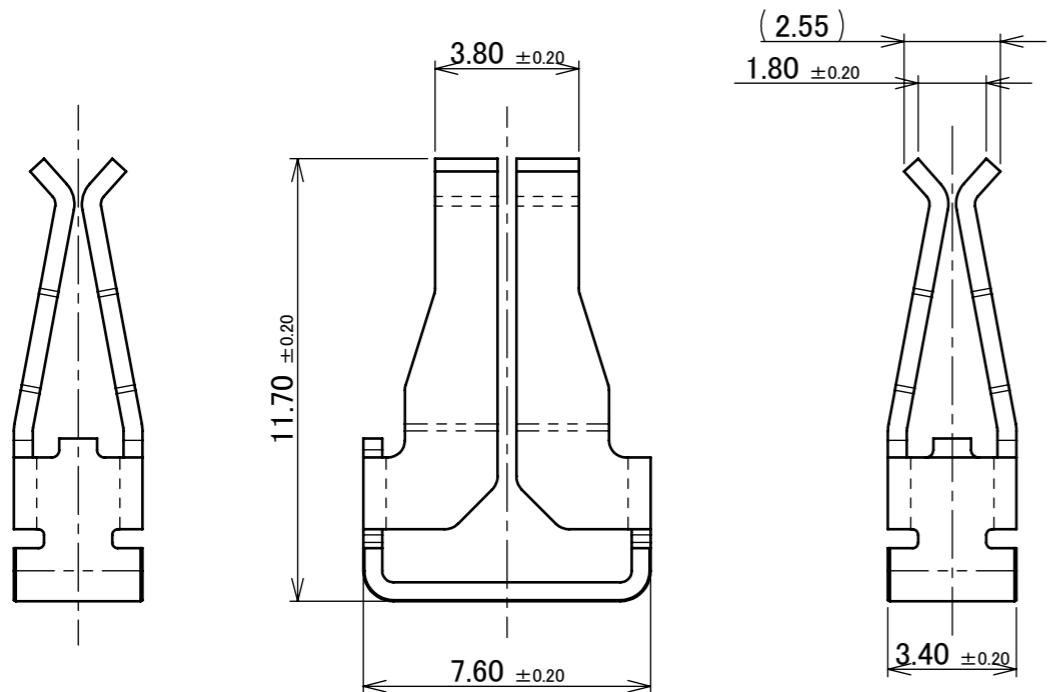
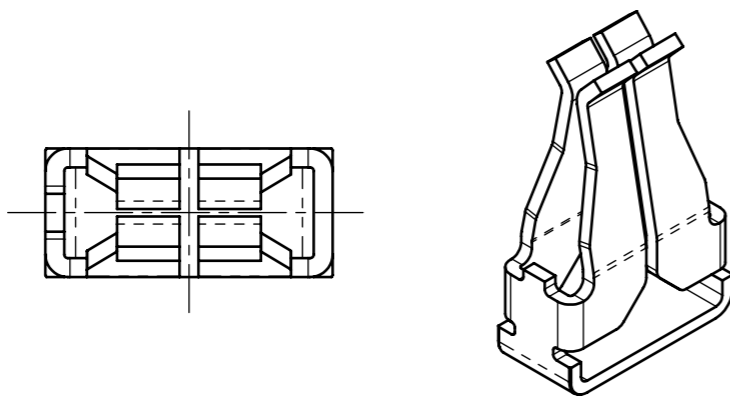
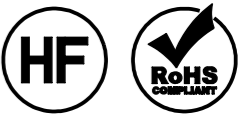
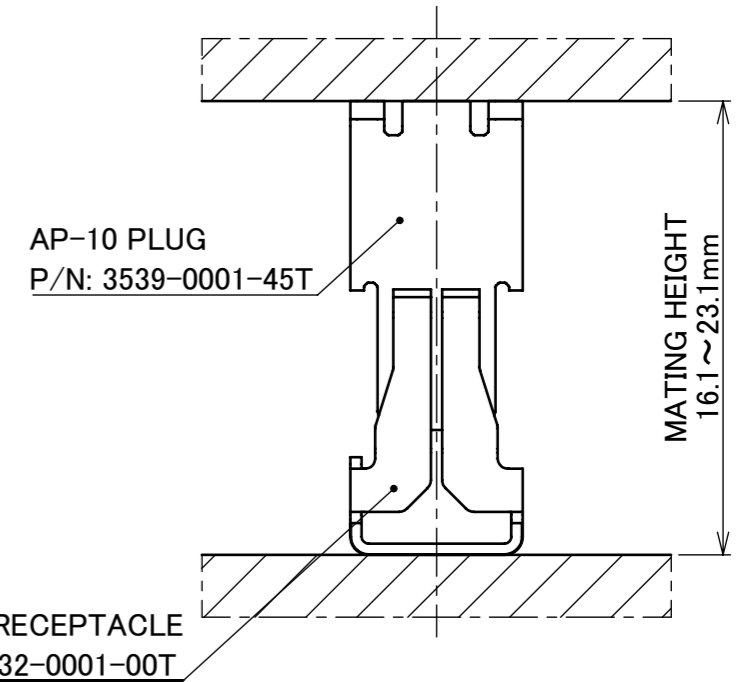

MATING CONDITION
【AP-10 PLUG H=14.5 mm】

NOTES.
1. APPLICABLE CONNECTOR
AP-10 PLUG H=7.5 mm (P/N: 3531-0001-00T)
AP-10 PLUG H=14.5 mm (P/N: 3539-0001-00T)

1	RECEPTACLE	COPPER ALLOY	Sn 1.00~4.50 μm OVER Ni 1.00~4.50 μm
NO.	DESCRIPTION	MATERIAL	FINISH , REMARKS

					ANGLE	±2°	6 OVER 30 MAX.	±0.3	PROJECTION	SERIES No.	CUSTOMER COPY	
					6 MAX.	±0.2	30 OVER 120 MAX.	±0.5	⊕	R1		
3	Z220290	K.T	2022/03/14	Y.H	GENERAL TOLERANCE.				TITLE	SCALE	I-PEX	
2	Z200243	K.T	2020/03/02	T.Y	DWG.	DATE		AP-10	5:1			
1	Z200117	T.Y	2020/01/27	Y.S	T.Yamauchi		2019/08/01	RECEPTACLE	UNIT			
0	Z191026	T.Y	2019/08/01		CHK.				mm			
REV.	ECN	BY	DATE	APP.	APP.	REVISION RECORD			DWG. No.	SIZE	SHEET	REV.
					Y.Shimada				3532	A3	1/4	3

ITEMS	SPECIFICATION
APPLICABLE CONNECTOR PART No.	3531-0001-00T 3539-0001-45T
RATING AMPERAGE	16A AC/DC
TEMPERATURE RISE	△15.0°C Max.
COMPONENT TEMPERATURE(ENERGIZATION)	233~378K(-40°C~+105°C)
OPERATING HUMIDITY	85% MAX.(NON-CONDENSING)
CONTACT RESISTANCE	INITIAL : 1.0 mohm MAX. / AFTER TEST : 1.0 mohm MAX.
DURABILITY	3 CYCLES
MATING FORCE	15.0 N MAX.
COPLANARITY	0.10mm MAX.
PRODUCT SPECIFICATION	PRS-2616
TEST REPORT	TR-19063
PACKING STANDARD	PST-17021
APPEARANCE CRITERIA No.	QLS-A***

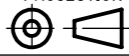
ANGLE	±2°	6 OVER 30 MAX.	±0.3	PROJECTION 	SERIES No. R1	CUSTOMER COPY		
6 MAX.	±0.2	30 OVER 120 MAX.	±0.5					
GENERAL TOLERANCE.				TITLE AP-10 RECEPTACLE	SCALE 5:1	I-PEX		
DWG.	DATE							
CHK.								
APP.								
				DWG. No.	3532	SIZE A3	SHEET 2/4	REV. 3

PART NO.
3532-0001-00T

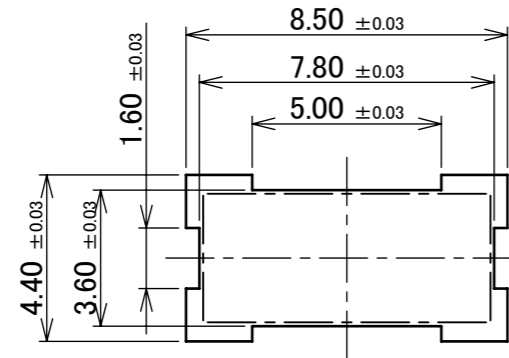

RECOMMENDED FOOTPRINT PATTERN

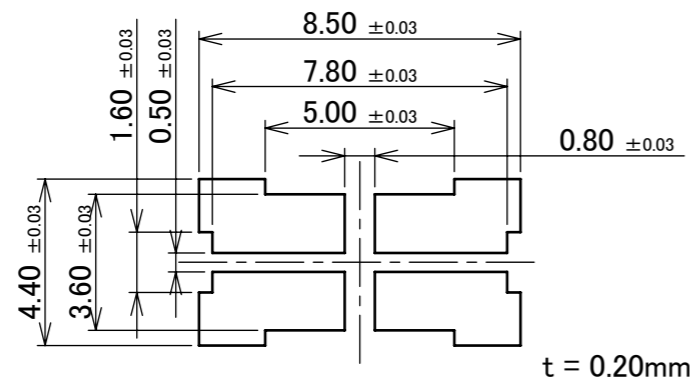

RECOMMENDED METAL MASK

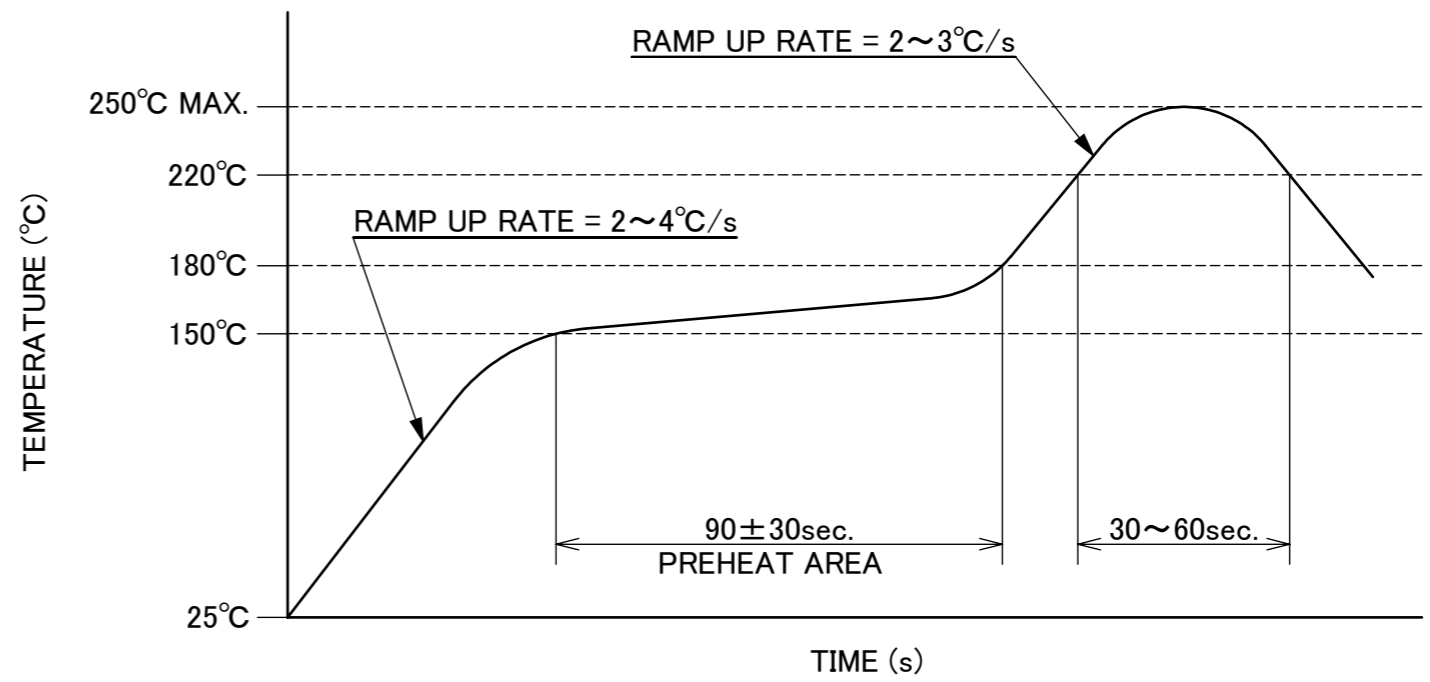

REFLOW TEMPERATURE PROFILE
SENJU METAL INDUSTRY CO., LTD. : M705-SHF(Sn96.5 Ag3.0 Cu0.5)

ANGLE	±2°	6 OVER 30 MAX.	±0.3	PROJECTION ⊕	SERIES No. R1	CUSTOMER COPY		
6 MAX.	±0.2	30 OVER 120 MAX.	±0.5					
GENERAL TOLERANCE.				TITLE AP-10 RECEPTACLE	SCALE 5:1 UNIT mm	I-PEX		
DWG.	DATE							
CHK.								
APP.								
				DWG. No.	3532	SIZE A3	SHEET 3/4	REV. 3

PART NO.	QTY. PER EMBOSS REEL (PIECES / REEL)	QTY. PER PACKING CARTON (REELS / CARTON)
3532-0001-00T	350 PIECES / REEL	5 REELS / CARTON = 1,750 PIECES

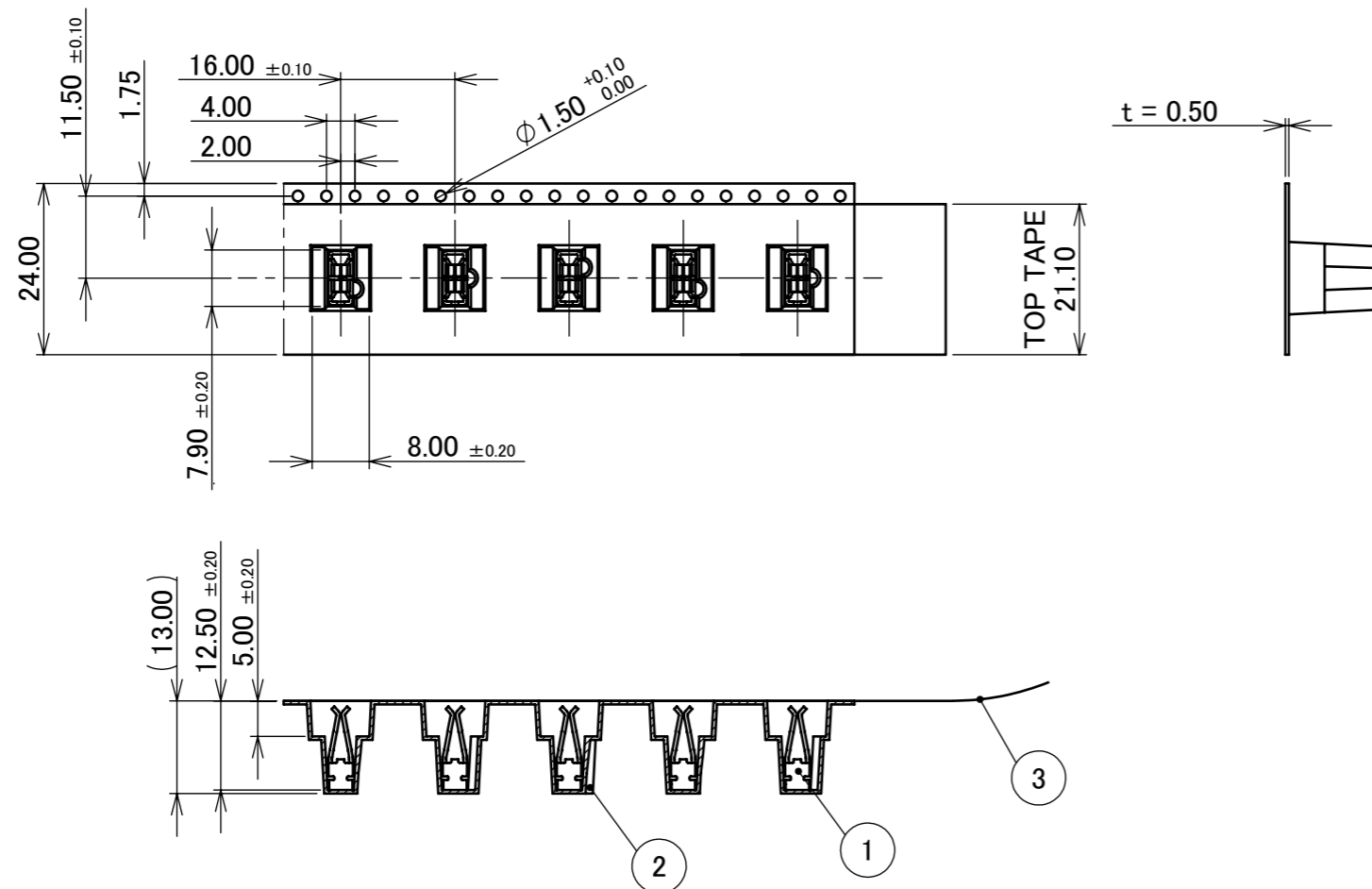
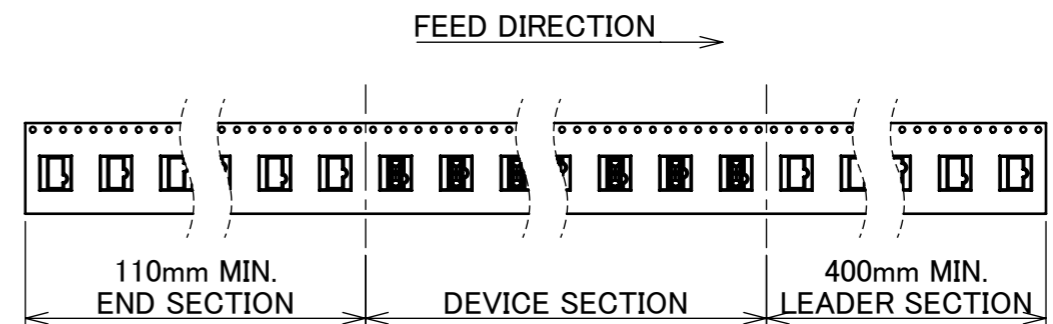
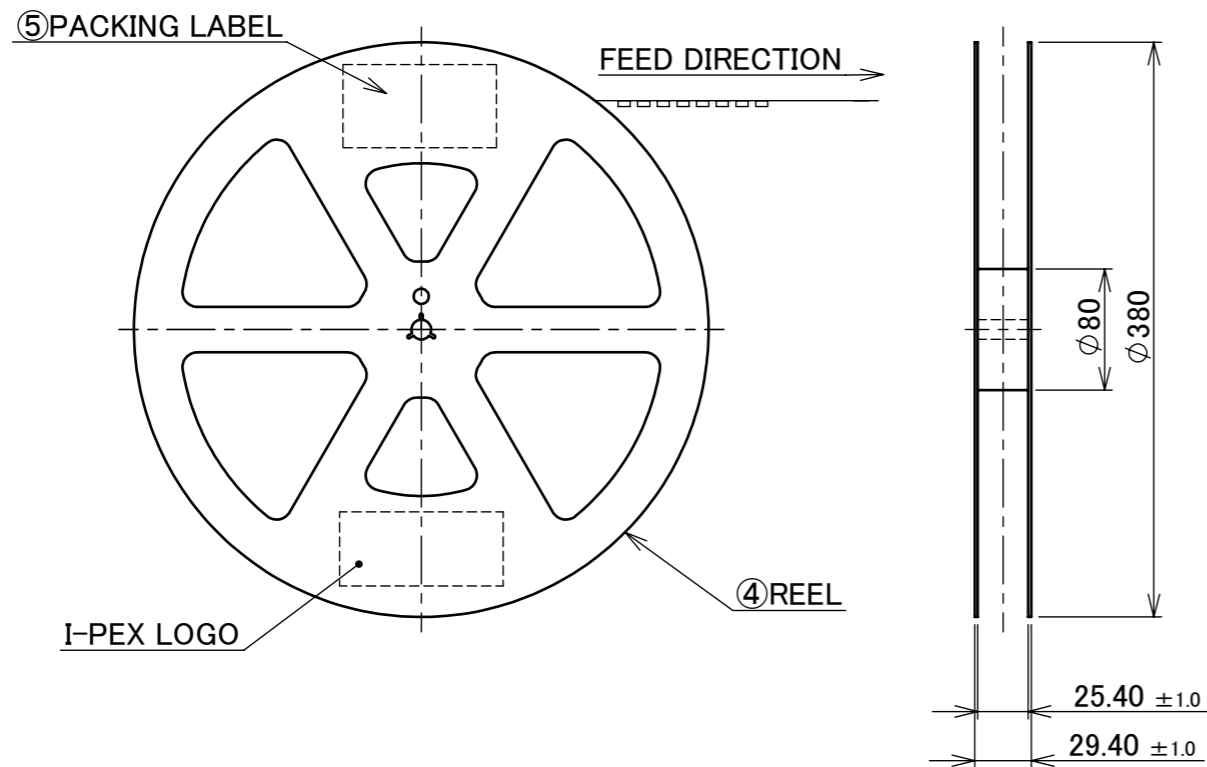

- NOTES.
- TAPING SPECIFICATION FOLLOWS JIS C 0806 (IEC 60286-3).
 - MAKE EMPTY SECTION OF LEADER AND END ON EACH END OF THE TAPE.
 - TOP TAPE SHALL NOT STICK OUT FROM EMBOSS TAPE.
 - TOP TAPE SHALL NOT COVER FEED HOLE.

NO.	DESCRIPTION	MATERIAL	FINISH, REMARKS
5	PACKING LABEL	-	-
4	REEL	PS	BLACK
3	TOP TAPE	PET	ANTI-STATIC TYPE
2	EMBOSS TAPE	PS	ANTI-STATIC TYPE
1	CONNECTOR	COPPER ALLOY	-

ANGLE	±2°	6 OVER 30 MAX.	±0.3	PROJECTION ⊕	SERIES No. R1	CUSTOMER COPY		
6 MAX.	±0.2	30 OVER 120 MAX.	±0.5					
GENERAL TOLERANCE.				TITLE AP-10 RECEPTACLE	SCALE 5:1	UNIT mm I-PEX		
DWG.	DATE							
CHK.								
APP.								
DWG. No.				3532	SIZE	SHEET	REV.	
					A3	4/4	3	