

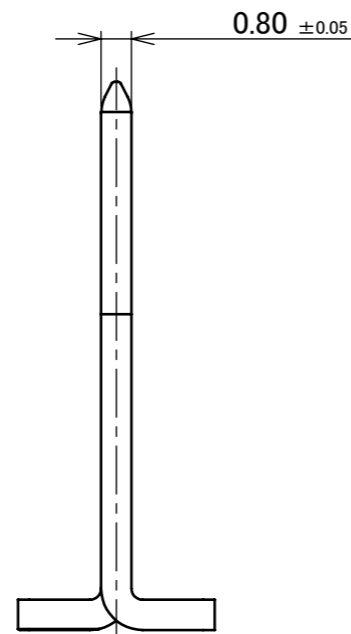

Halogen Free

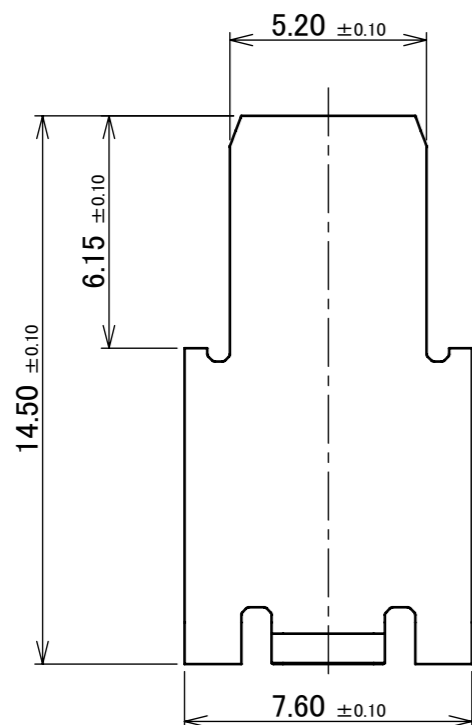

RoHS Compliant

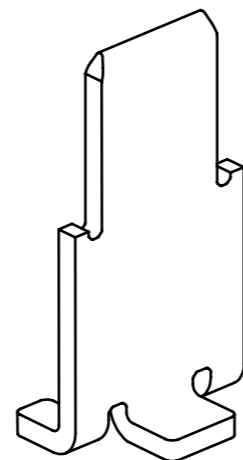
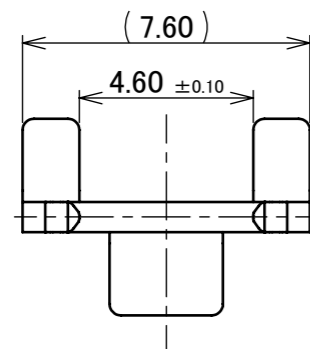

AP-10 PLUG  
(HEIGHT CHANGE TYPE)  
P/N: 3539-0001-45T

AP-10 RECEPTACLE  
P/N: 3532-0001-00T

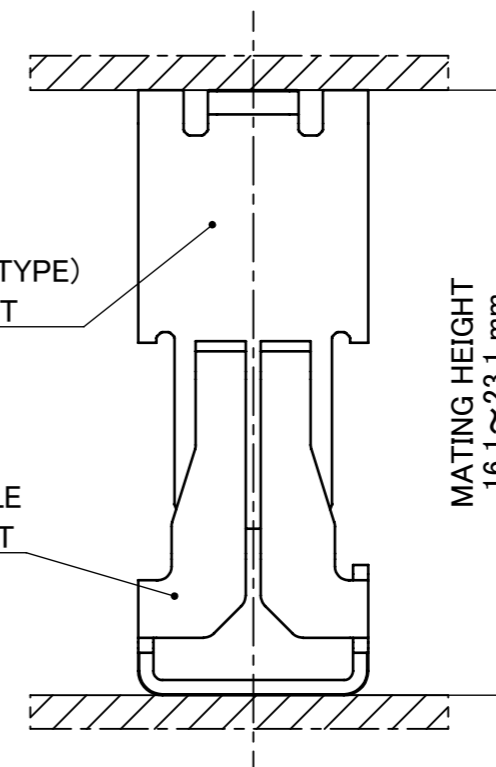

MATING CONDITION

NOTES.

1. APPLICABLE CONNECTOR  
AP-10 RECEPTACLE (P/N: 3532-0001-00T)

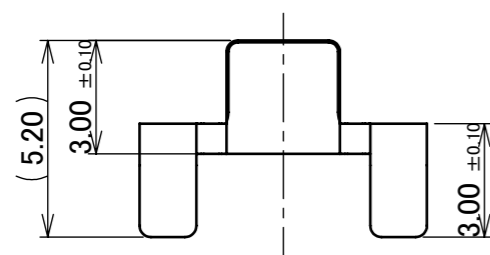

1	PLUG	BRASS	Sn 1.00~4.50 μm OVER Ni 1.00~4.50 μm
NO.	DESCRIPTION	MATERIAL	REMARKS, FINISH

				ANGLE	±2°	6 OVER 30 MAX.	±0.3	PROJECTION ⊕	SERIES No. R2	CUSTOMER COPY			
					6 MAX.	±0.2	30 OVER 120 MAX.			±0.5	SCALE 5:1	I-PEX	
				GENERAL TOLERANCE.				TITLE AP-10 PLUG (HEIGHT CHANGE TYPE)	UNIT mm				
0	Z220290	K.T	2022/03/14	DWG.	K.Tanaka		DATE	2022/03/14		SIZE			
REV.	ECN	BY	DATE	APP.	CHK.	-		DWG. No.	3539	SHEET	1/4	REV.	0
REVISION RECORD				Y.Hashimoto									

ITEMS	SPECIFICATION
APPLICABLE CONNECTOR PART No.	3532-0001-00T
RATING AMPERAGE	16A AC/DC
TEMPERATURE RISE	△15.0°C MAX
COMPONENT TEMPERATURE (ENERGIZATION)	233~378K(-40°C~105°C)
OPERATING HUMIDITY	85% MAX.(NON-CONDENSING)
CONTACT RESISTANCE	INITIAL : 1.0 mohm MAX. / AFTER TEST : 1.0 mohm MAX.
DURABILITY	3 CYCLES
MATING FORCE	15.0 N MAX.
COPLANARITY	0.10mm MAX.
PRODUCT SPECIFICATION	PRS-2616
TEST REPORT	TR-19063
PACKING STANDARD	PST-22010
APPEARANCE CRITERIA No.	QLS-A***

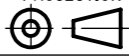
ANGLE	±2°	6 OVER 30 MAX.	±0.3	PROJECTION 	SERIES No. R2	CUSTOMER COPY		
6 MAX.	±0.2	30 OVER 120 MAX.	±0.5					
GENERAL TOLERANCE.				TITLE PLUG (HEIGHT CHANGE TYPE)	SCALE 5:1 UNIT mm	<b>I-PEX</b>		
DWG.	DATE							
CHK.								
APP.								
				DWG. No.	3539	SIZE A3	SHEET 2/4	REV. 0

PART NO.  
3539-0001-45T

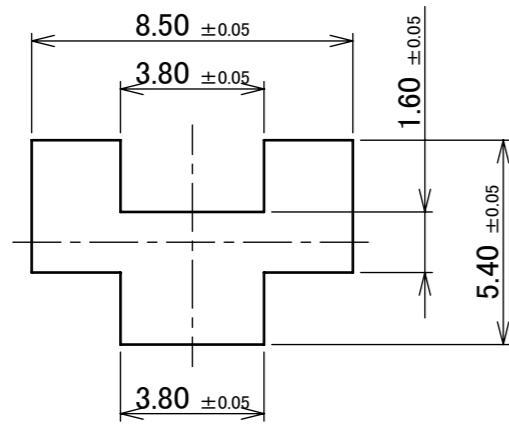

RECOMMENDED PATTERN LAYOUT

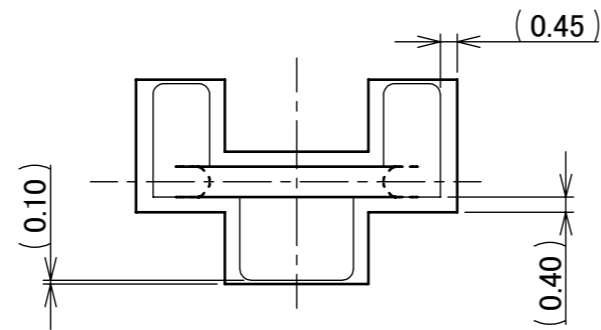

CONNECTOR ON RECOMMENDED PATTERN

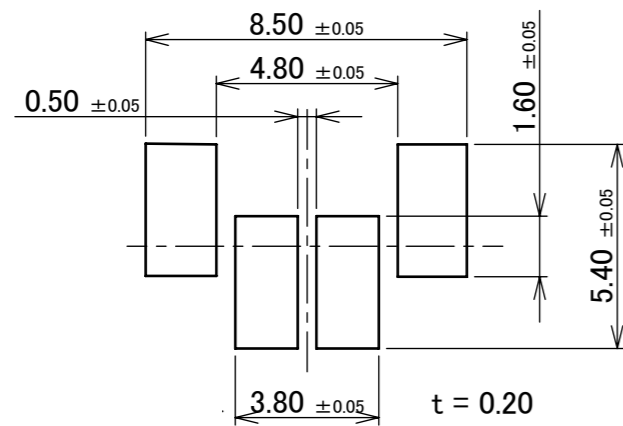

RECOMMENDED METAL MASK LAYOUT

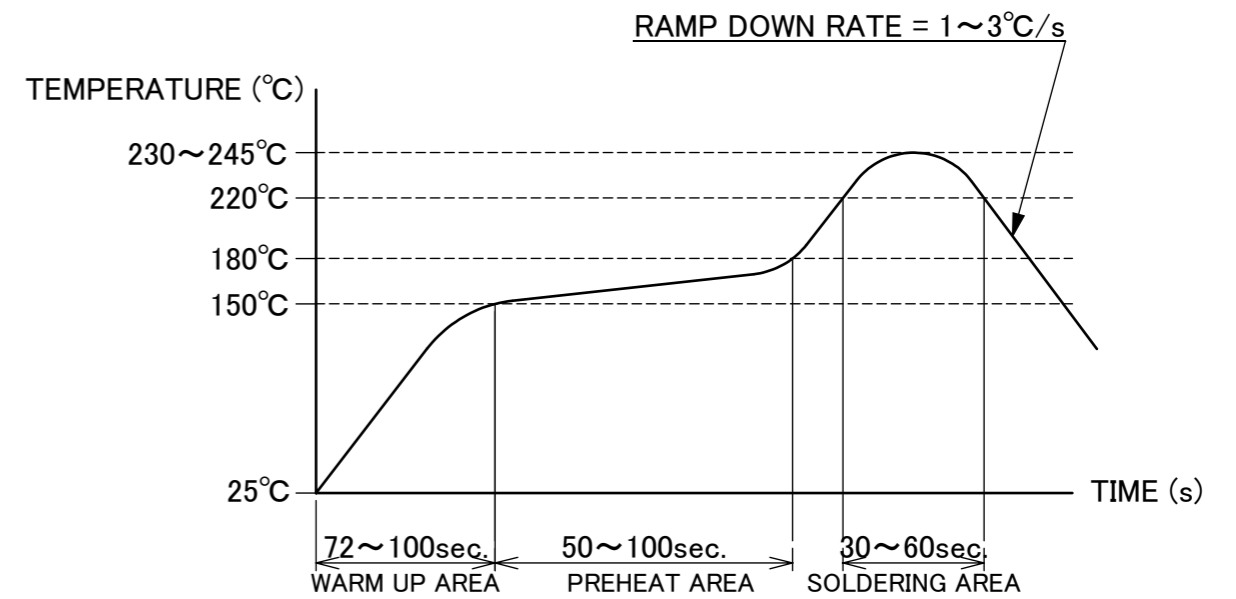

REFLOW TEMPERATURE PROFILE  
SENJU METAL INDUSTRY CO., LTD. : M705-SHF(Sn96.5 Ag3.0 Cu0.5)

ANGLE	±2°	6 OVER 30 MAX.	±0.3	PROJECTION ⊕	SERIES No. R2	CUSTOMER COPY		
6 MAX.	±0.2	30 OVER 120 MAX.	±0.5					
GENERAL TOLERANCE.				TITLE PLUG (HEIGHT CHANGE TYPE)	SCALE 5:1 UNIT mm	I-PEX		
DWG.	DATE							
CHK.								
APP.								
				DWG. No.	3539	SIZE A3	SHEET 3/4	REV. 0

PART NO.	C	D	E	QTY. PER TRAY (PIECES / TRAY)	QTY. PER PACKING CARTON (TRAYS / CARTON)
3539-0001-45T	19.0	7.0	19.0	190 PIECES / TRAY	4 TRAYS / CARTON = 760 PIECES

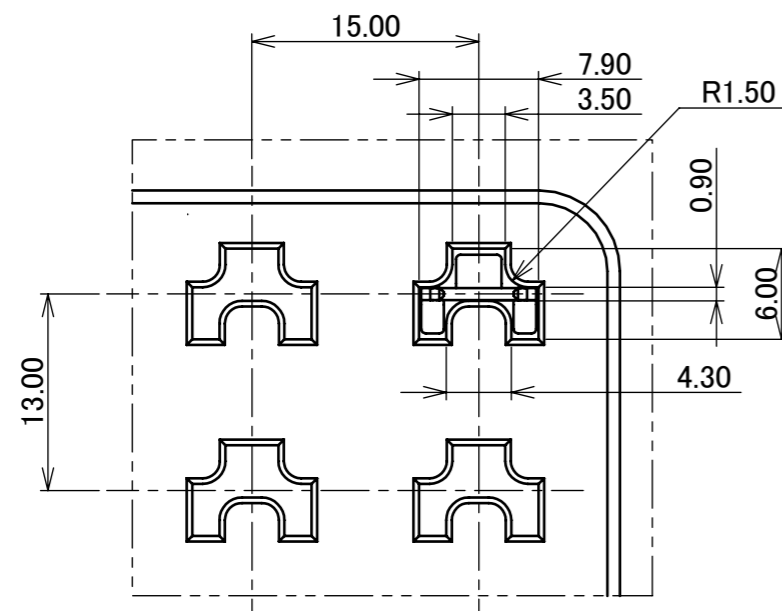
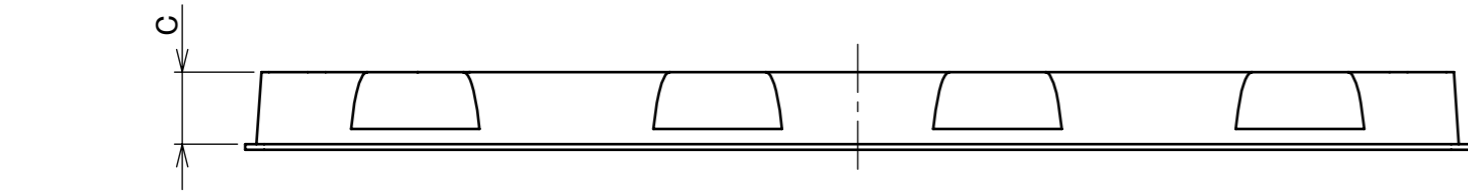
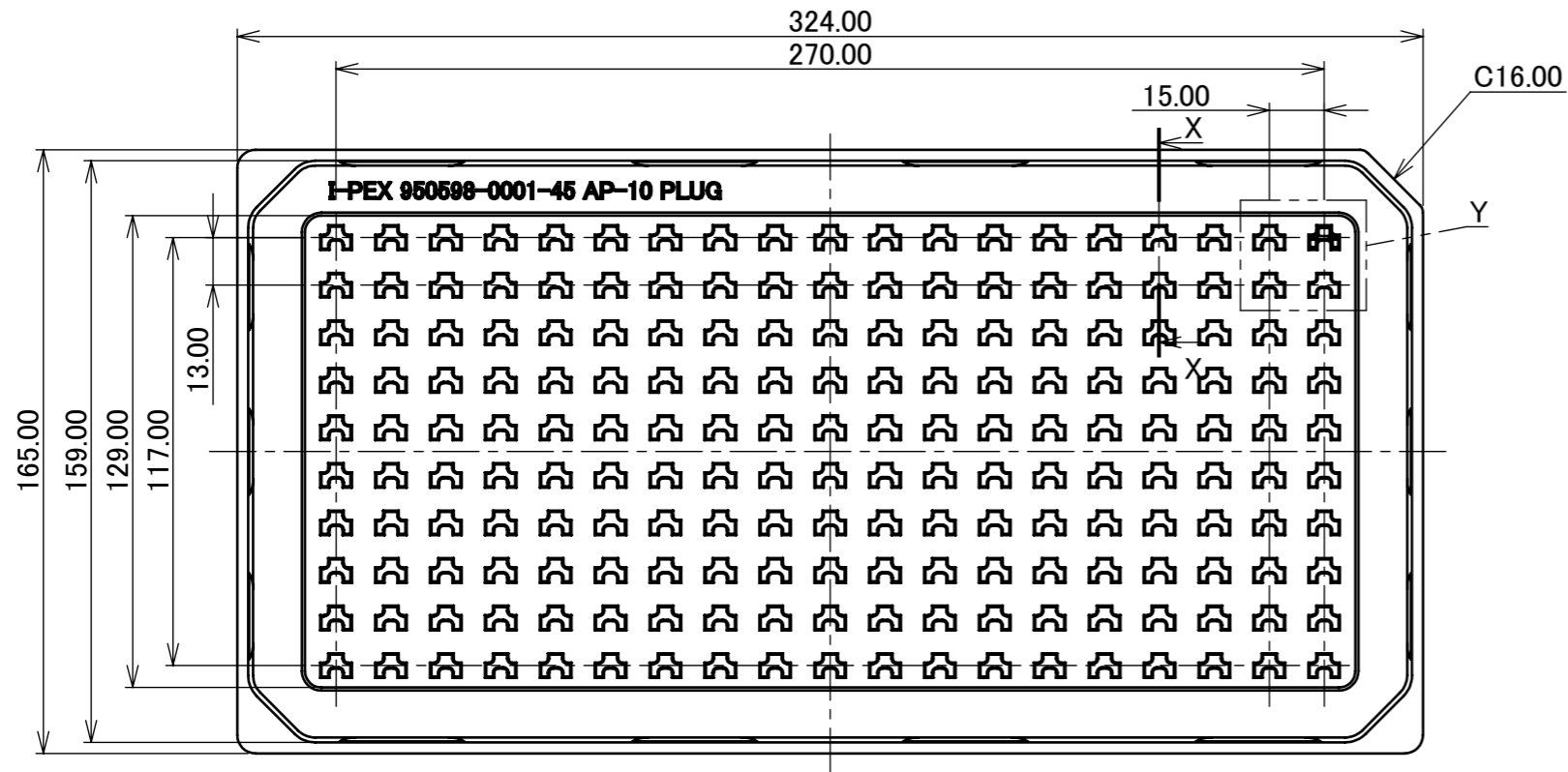

DETAIL Y  
S = 2 / 1

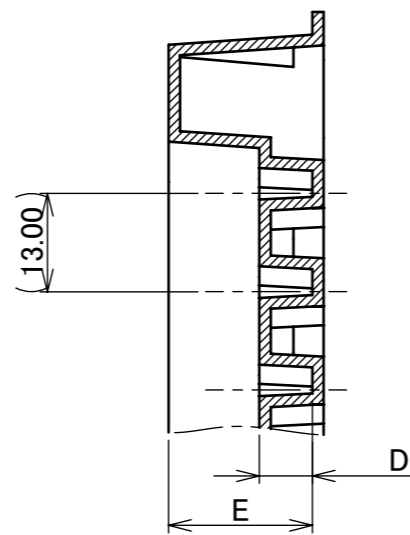

SECT. X-X  
S = 1 / 1

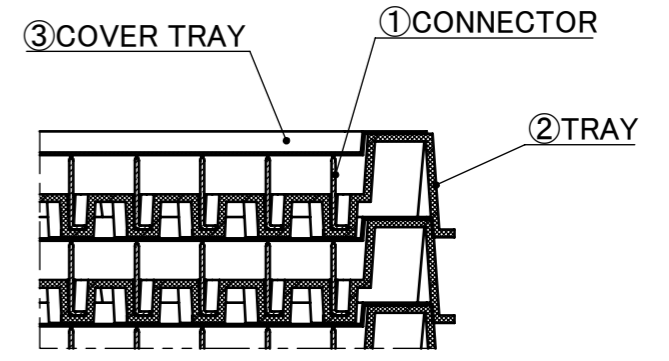
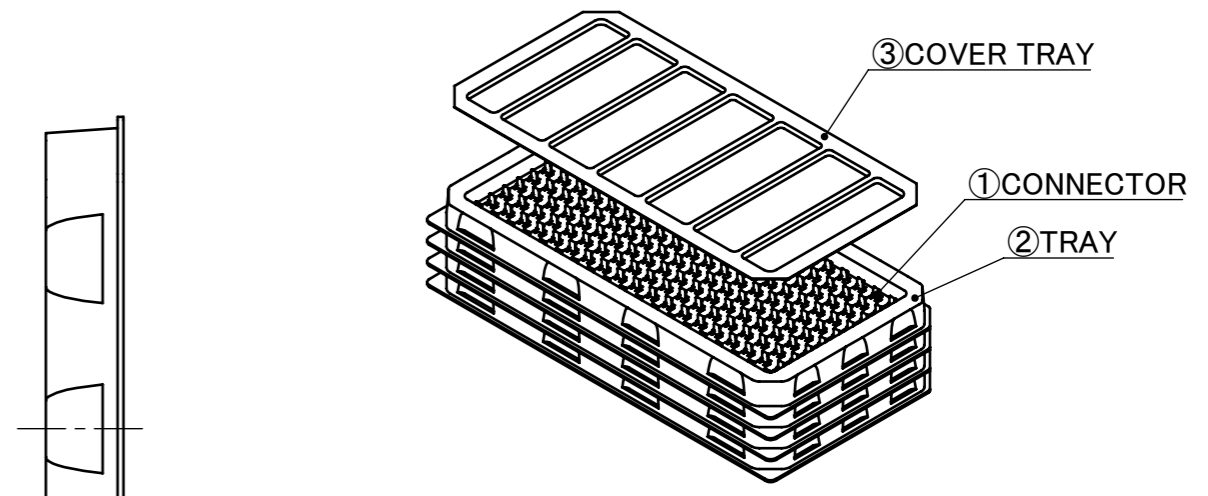

PILED TRAY CONDITION

NO.	DESCRIPTION	MATERIAL	REMARKS
3	COVER TRAY	PS t=0.50mm	WHITE
2	TRAY	PS t=1.50mm	WHITE
1	CONNECTOR	BRASS	-

ANGLE	±2°	6 OVER 30 MAX.	±0.3	PROJECTION	SERIES No.	CUSTOMER COPY		
6 MAX.	±0.2	30 OVER 120 MAX.	±0.5		R2			
GENERAL TOLERANCE.				TITLE	SCALE		UNIT	
DWG.	DATE			PLUG (HEIGHT CHANGE TYPE)	1:2		I-PEX	
CHK.				DWG. No.	3539	SIZE	SHEET	REV.
APP.						A3	4/4	0