

Recommended P/N 3531-0001-00T

PART NO.
3531-0001-00T

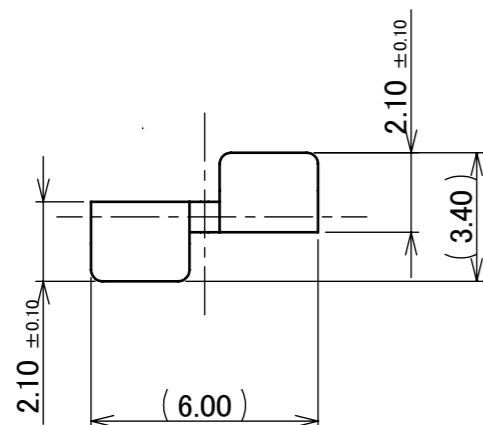
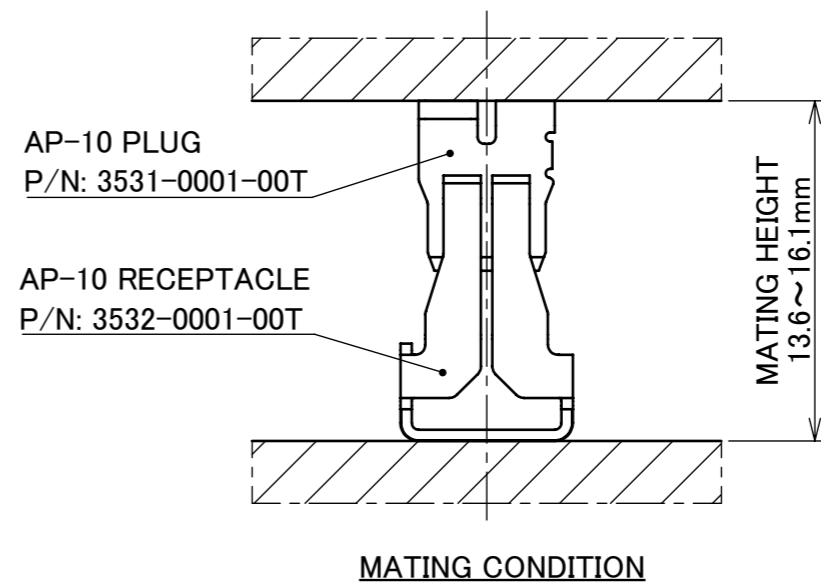
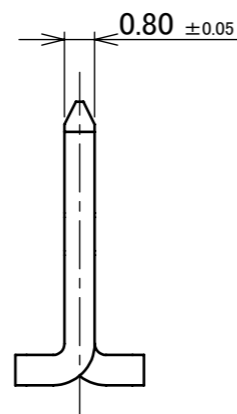
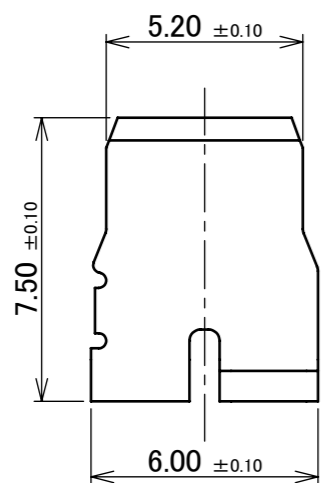
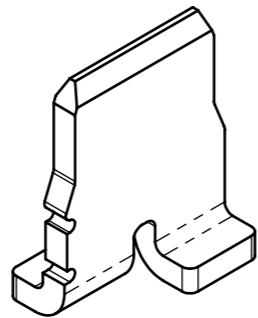
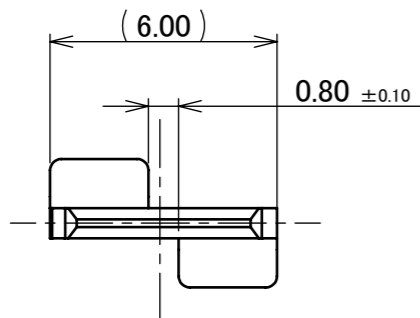
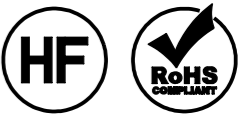

NOTES.
1. APPLICABLE CONNECTOR
AP-10 RECEPTACLE (P/N: 3532-0001-00T)

1	PLUG	BRASS	Sn 1.00 μm ~ 4.50 μm OVER Ni 1.00 μm ~ 4.50 μm
NO.	DESCRIPTION	MATERIAL	FINISH , REMARKS

					ANGLE	±2°	6 OVER 30 MAX.	±0.3	PROJECTION	SERIES No.	CUSTOMER COPY	
					6 MAX.	±0.2	30 OVER 120 MAX.	±0.5		R1		
3	Z220290	K.T	2022/03/14	Y.H	GENERAL TOLERANCE.				TITLE AP-10 PLUG	SCALE	I-PEX	
2	Z200243	K.T	2020/03/02	T.Y	DWG.	DATE		UNIT		5:1		
1	Z200117	T.Y	2020/01/27	Y.S	T.Yamauchi		2019/08/01			mm		
0	Z191026	T.Y	2019/08/01		CHK.	-		SIZE		SHEET		REV.
REV.	ECN	BY	DATE	APP.	APP.	Y.Shimada		DWG. No.	3531	A3	1/4	3

ITEMS	SPECIFICATION
APPLICABLE CONNECTOR PART No.	3532-0001-00T
RATING AMPERAGE	16A AC/DC
TEMPERATURE RISE	△15.0°C MAX.
COMPONENT TEMPERATURE(ENERGIZATION)	233~378K(-40°C~+105°C)
OPERATING HUMIDITY	85% MAX.(NON-CONDENSING)
CONTACT RESISTANCE	INITIAL : 1.0 mohm MAX. / AFTER TEST : 1.0 mohm MAX.
DURABILITY	3 CYCLES
MATING FORCE	15.0 N MAX.
COPLANARITY	0.10mm MAX.
PRODUCT SPECIFICATION	PRS-2616
TEST REPORT	TR-19063
PACKING STANDARD	PST-17120
APPEARANCE CRITERIA No.	QLS-A***

ANGLE	±2°	6 OVER 30 MAX.	±0.3	PROJECTION 	SERIES No. R1	CUSTOMER COPY		
6 MAX.	±0.2	30 OVER 120 MAX.	±0.5					
GENERAL TOLERANCE.				TITLE AP-10 PLUG	SCALE 5:1 UNIT mm	I-PEX		
DWG.	DATE							
CHK.								
APP.								
				DWG. No.	3531	SIZE A3	SHEET 2/4	REV. 3

PART NO.
3531-0001-00T

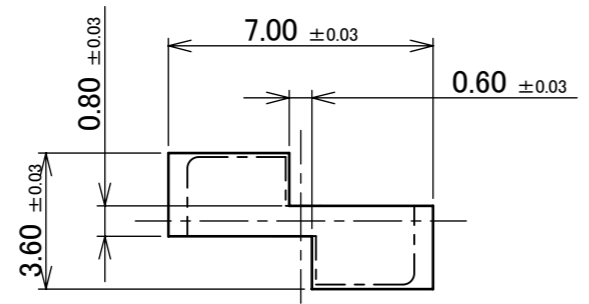

RECOMMENDED FOOTPRINT PATTERN

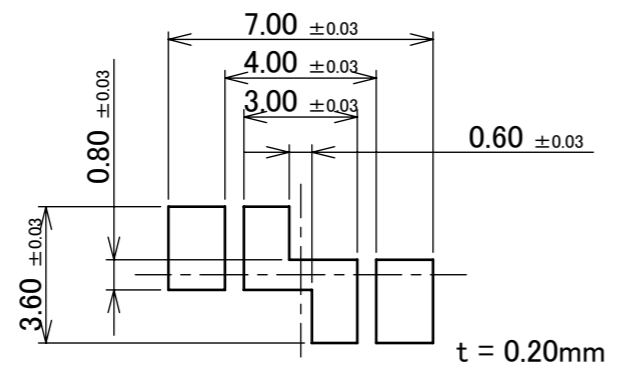

RECOMMENDED METAL MASK

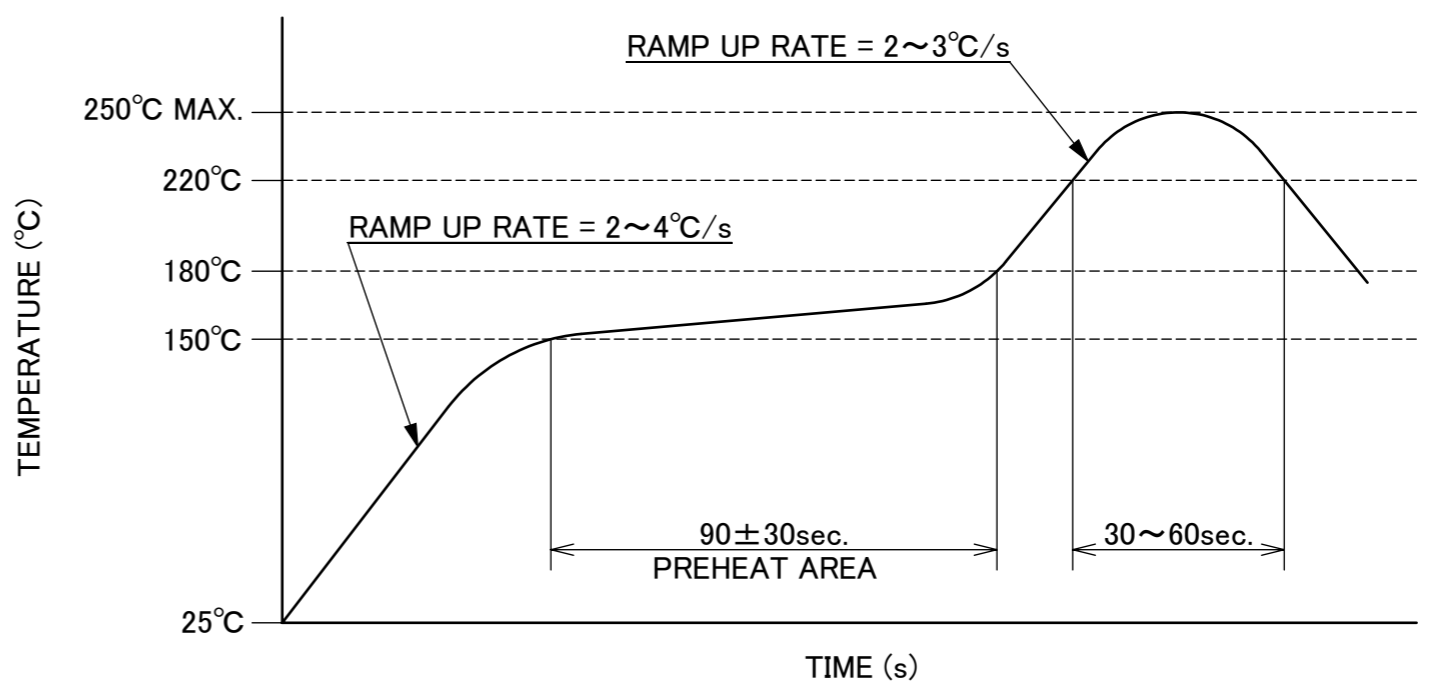

REFLOW TEMPERATURE PROFILE
SENJU METAL INDUSTRY CO., LTD. : M705-SHF(Sn96.5 Ag3.0 Cu0.5)

ANGLE	±2°	6 OVER 30 MAX.	±0.3	PROJECTION ⊕	SERIES No. R1	CUSTOMER COPY		
6 MAX.	±0.2	30 OVER 120 MAX.	±0.5					
GENERAL TOLERANCE.				TITLE AP-10 PLUG	SCALE 5:1	UNIT I-PEX		
DWG.	DATE							
CHK.								
APP.								
				DWG. No.	3531	SIZE A3	SHEET 3/4	REV. 3

PART NO.	QTY. PER EMBOSS REEL (PIECES / REEL)	QTY. PER PACKING CARTON (REELS / CARTON)
3531-0001-00T	700 PIECES / REEL	5 REELS / CARTON = 3,500 PIECES

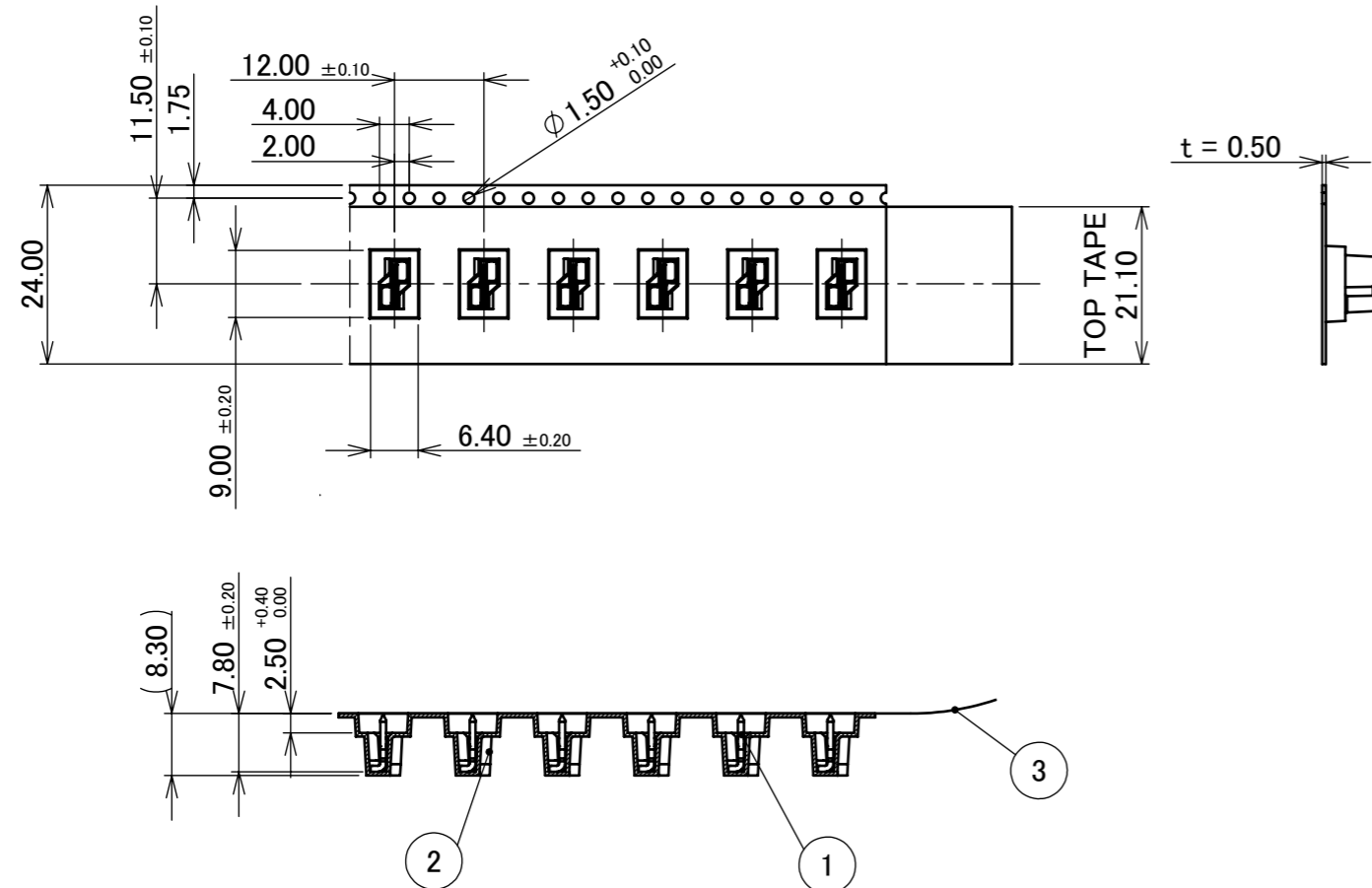
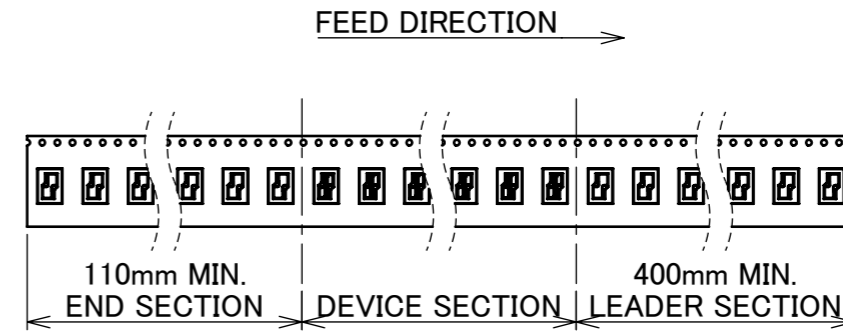
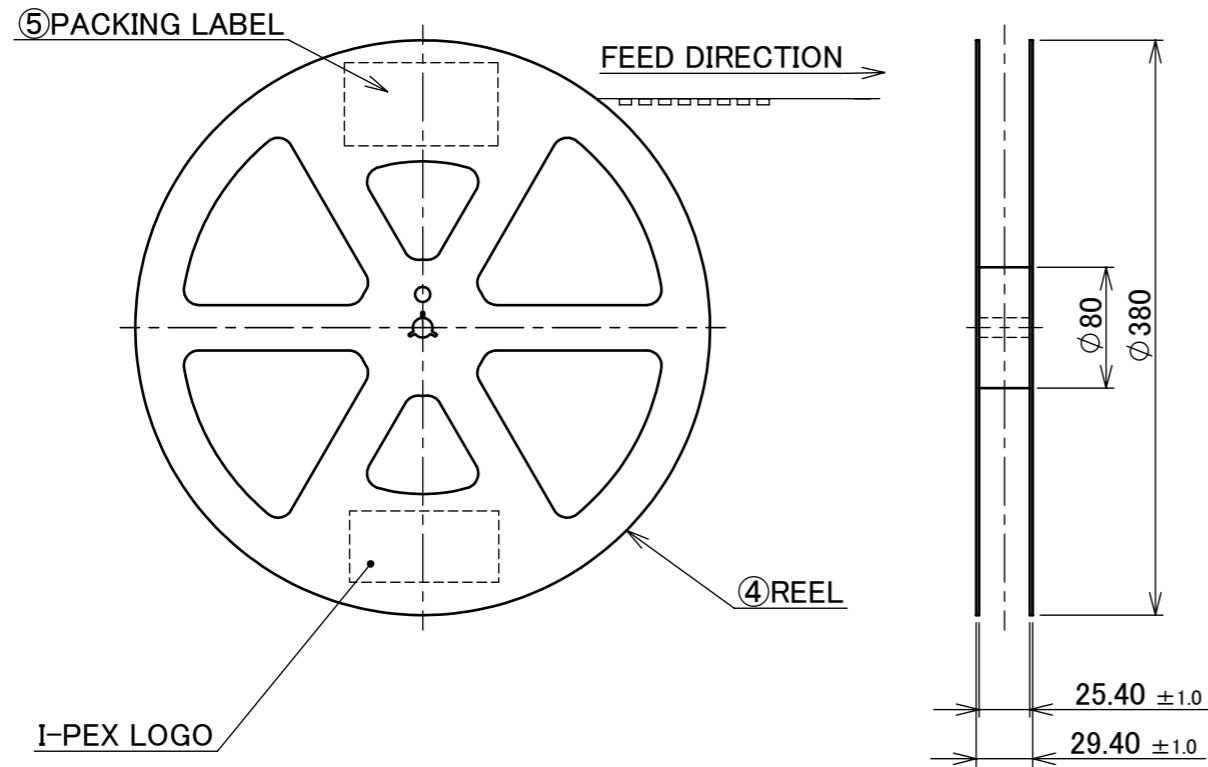

- NOTES.
2. TAPING SPECIFICATION FOLLOWS JIS C 0806 (IEC 60286-3).
 3. MAKE EMPTY SECTION OF LEADER AND END ON EACH END OF THE TAPE.
 4. TOP TAPE SHALL NOT STICK OUT FROM EMBOSS TAPE.
 5. TOP TAPE SHALL NOT COVER FEED HOLE.

NO.	DESCRIPTION	MATERIAL	FINISH, REMARKS
5	PACKING LABEL	-	-
4	REEL	PS	BLACK
3	TOP TAPE	PET	ANTI-STATIC TYPE
2	EMBOSS TAPE	PS	ANTI-STATIC TYPE
1	CONNECTOR	BRASS	Sn OVER Ni

ANGLE	±2°	6 OVER 30 MAX.	±0.3	PROJECTION ⊕	SERIES No. R1	CUSTOMER COPY		
6 MAX.	±0.2	30 OVER 120 MAX.	±0.5					
GENERAL TOLERANCE.				TITLE AP-10 PLUG	SCALE 5:1	UNIT I-PEX		
DWG.	DATE							
CHK.								
APP.								
				DWG. No.	3531	SIZE A3	SHEET 4/4	REV. 3