

IARPB® CONNECTOR

Product Specification

Qualification Test Report No. STR-16040,-16041,-16042,-16043

3	RS0739	Oct. 22/'20	T.Hoshino	M.Muta	J.Tateishi
2	RS0479	June 14/'18	Y.Takagi	/	E.Kawabe
1	RS0452	Jan. 12/'18	S.Ohashi		T.Endo
0	RS0406	Dec. 5/'17	S.Ohashi	E.Kawabe	T.Endo
Rev.	ECN	Date	Prepared by	Checked by	Approved by

1. Scope

This connector is PCB direct attachment connector of 2.5mm terminal pitch.

2. Purpose

This specification covers the requirements for product performance and test methods of IARPB CONNECTOR.

3. Application items

This specification is applicable to the items listed below.

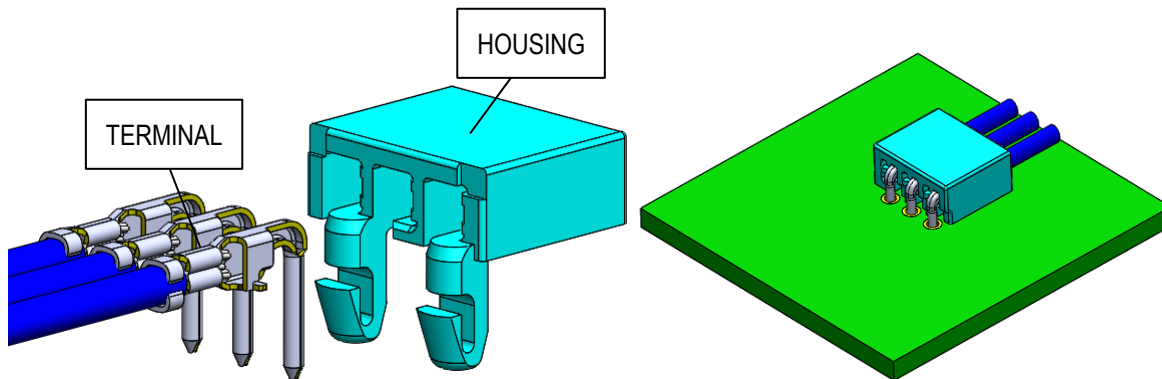

Table1 Product Line

POLE	PARTS No.	
	HOUSING	TERMINAL
2P	V0039-91002-2Z1	V0039-71001-011
3P	V0039-91003-2Z1	
4P	V0039-91004-2Z1	
5P	V0039-91005-2Z1	

4. Operating Condition

Temperature : -40~+105°C (including temperature rise)

5. Construction, Materials and finish and applicable Cable and PCB

5.1 IARPB CONNECTOR

(1)HOUSING.....GLASS FILLED PBT , UL94-HB , NATURAL

(2)TERMIANL.....BRASS , Sn(REFLOW)

(3)Applicable cable.....0.3mm² OUTER DIAMETERφ1.67mm MAX.

(4)Applicable PCB.....THICKNESS t=1.60±0.15mm , PIN HOLE φ1.0±0.05mm , BOSS HOLE φ2.3±0.05mm

5.2 TERMINAL CRIMP SPECIFICATION

Terminal crimp specification is complaint with instruction manual 【HDM-0005】

6. Test Items and Performances

6.1 Initial characteristics test

Test methods of Initial characteristics test are described in 7.1

Table2 Initial characteristics

Item	Measurement	Requirements	
1	Terminal and Housing appearance	No detrimental deformation	
2	Terminal outer dimension	Satisfy drawing dimension	
3	Housing outer dimension	Satisfy drawing dimension	
4	Terminal retention force	30N Min.	
5	Solderability	The land area on both sides of the PCB is wet all around and fillets are formed.	
6	Terminal crimp strength	Initial	50N Min.
		After test	40N Min.
7	Voltage drop	Initial	2mV/A Max.
		After test	3mV/A Max.
8	Dry circuit resistance	Initial	2mΩ Max.
		After test	3mΩ Max.
9	Insulation resistance	100MΩ Min.	
10	Dielectric withstanding voltage	No insulation breakdown or erosion	
11	Temperature rise	$\Delta T=40^{\circ}\text{C}$ Max.	
12	Leak current	3mA Max.	
13	Short break monitor	Not exceed 1μs and 7Ω	
14	Resistance variation	20mΩ Max.	
15	Insertion force of terminal to the housing	15N Max.	
16	Terminal/Cavity polarization	Unable to insert terminal incorrectly at 49N	
17	PCB retention force	2P	30N Min.
		3,4,5P	70N Min.
18	PCB insertion force	2P	15N Max.
		3,4P	25N Max.
		5P	37.5N Max.

6.2 Environmental Performances

Test method is described in 7.2 Environmental Performances Test Method.

Table3 Environmental Performances

Item	Test name	Measurement	Requirements
1	High temperature aging	Terminal and Housing appearance	No detrimental deformation
		Terminal retention force	30N Min.
		Voltage drop	3mV/A Max.
		Dry circuit resistance	3mΩ Max.
		Temperature Rise	$\Delta T=40^{\circ}\text{C}$ Max.
2	Low temperature aging	Terminal and Housing appearance	No detrimental deformation
		Terminal retention force	30N Min.
		Voltage drop	3mV/A Max.
		Dry circuit resistance	3mΩ Max.
		Temperature Rise	$\Delta T=40^{\circ}\text{C}$ Max.
3	Thermal shock	Terminal and Housing appearance	No detrimental deformation
		Terminal retention force	30N Min.
		Voltage drop	3mV/A Max.
		Dry circuit resistance	3mΩ Max.
		Temperature Rise	$\Delta T=40^{\circ}\text{C}$ Max.
		Resistance variation	Under test 20mΩ Max.
4	Temperature/humidity cycle	Terminal and Housing appearance	No detrimental deformation
		Terminal retention force	30N Min.
		Voltage drop	3mV/A Max.
		Dry circuit resistance	3mΩ Max.
		Insulation resistance	100MΩ Min.
		Dielectric Withstanding Voltage	No insulation breakdown or erosion
		Leak Current	Under test 3mA Max.
		Resistance variation	Under test 20mΩ Max.

Table4 Environmental Performances

Item	Test name	Measurement	Requirements
5	Humidity	Terminal and Housing appearance	No detrimental deformation
		Terminal retention force	30N Min.
		Voltage drop	3mV/A Max.
		Dry circuit resistance	3mΩ Max.
		Insulation resistance	100MΩ Min.
		Dielectric Withstanding Voltage	No insulation breakdown or erosion
		Leak Current	Under test
6	Corrosion gas	Terminal and Housing appearance	No detrimental deformation
		Terminal crimp strength	40N Min.
		Voltage drop	3mV/A Max.
		Dry circuit resistance	3mΩ Max.
7	Mechanical vibration	Terminal and Housing appearance	No detrimental deformation
		Voltage drop	3mV/A Max.
		Dry circuit resistance	3mΩ Max.
		Temperature Rise	ΔT=40°C Max.
		Short break monitor	Under test
8	Mechanical shock	Terminal and Housing appearance	No detrimental deformation
		Voltage drop	3mV/A Max.
		Short break monitor	Under test
9	Overcurrent	Terminal and Housing appearance	No detrimental deformation
		Voltage drop	3mV/A Max.
		Dry circuit resistance	3mΩ Max.

Table5 Environmental Performances

Item	Test name	Measurement	Requirements
10	Vibration with temperature change	Terminal and Housing appearance	No detrimental deformation
		Terminal retention force	30N Min.
		Voltage drop	3mV/A Max.
		Dry circuit resistance	3mΩ Max.
		Insulation resistance	100MΩ Min.
		Dielectric Withstanding Voltage	No insulation breakdown or erosion
		Temperature Rise	ΔT=40°C Max.
		Leak Current	3mA Max.
		Short break monitor	Not exceed 1μs and 7Ω
		11	Condensation
Insulation resistance	100MΩ Min.		
Leak Current	3mA Max.		
12	Rush current	Terminal and Housing appearance	No detrimental deformation
		Voltage drop	3mV/A Max.
		Dry circuit resistance	3mΩ Max.
		Temperature Rise	ΔT=40°C Max.
13	High temperature operability	Insert terminal into housing	After test No breaking, damage etc.
14	Resistance to stress corrosion	Terminal and Housing appearance	No detrimental deformation
		Terminal crimp strength	40N Min.
15	Current cycle	Terminal and Housing appearance	No detrimental deformation
		Terminal retention force	30N Min.
		Terminal crimp strength	40N Min.
		Voltage drop	3mV/A Max.
		Dry circuit resistance	3mΩ Max.
		Temperature Rise	ΔT=40°C Max.
16	Sulfur dioxide gas	Terminal and Housing appearance	No detrimental deformation
		Dry circuit resistance	3mΩ Max.

7. Test method

7.1 Test Method of Initial characteristics

(1) Terminal and Housing appearance

Test method... Visual(e.g. magnifier) and tactile verification.

(2) Terminal outer dimension

Test method ... Measure dimensions using caliper, micrometer and projector.

(3) Housing outer dimension

Test method ... Measure dimensions using caliper, micrometer and projector.

(4) Terminal retention force

Test method... Insert terminal crimped wire into housing completely.

Clamp wire with JIG at 100mm from the terminal crimp.

Measure the force required to pull out of the terminal

along the terminal insertion direction at a uniform rate of 100 mm/min.

(5) Solderability

Test method ... For lead-free soldering, soak the solder side of PCB at $260\pm 5^{\circ}\text{C}$ and 10 ± 1 second.

Then remove the sample and leave at the room temperature for over 30 minutes and observe it.

(6) Terminal crimp strength

Test method ... Clamp wire crimped terminal with JIG at 100mm from the terminal crimp along the axial direction at a uniform rate of 100 mm/min.

Measure the force required to break the wire or pull out of the crimp.

Do not use insulation barrel. (Do not crimp.)

(7) Voltage drop

Test method ... Open: $12\pm 1\text{V}$, Short circuit: (a) $1\pm 0.05\text{A}$ (b) $3\pm 0.05\text{A}$

Measure the potential difference at Fig. 1.

Then, subtract voltage drop of wires.

(8) Dry circuit resistance

Test method ... Open: $20\pm 5\text{mV}$, Short circuit: (a) $10\pm 0.5\text{mA}$ (b) $1\pm 0.5\text{mA}$

Measure the resistance at Fig. 1.

Then, subtract resistance of wires.

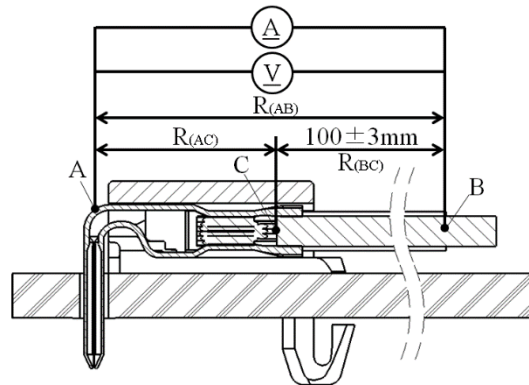

Fig.1 Voltage drop and Dry circuit resistance test method

(9) Insulation resistance

Test method ... Apply DC500V and measure insulation resistance between (a) terminals (b) terminal and earth on PCB mounted connector.

(10) Dielectric withstanding voltage

Test method ... Apply AC1000V for 1 minute between (a) terminals (b) terminal and earth on PCB mounted connectors.

(11) Temperature rise

Test method ... Apply current to PCB mounted connector and measure the temperature rise of crimp when temperature is saturated. Wire length: 300mm

Single pole : 7A to 1 terminal

All poles : Connect all poles and apply the current that is calculated by 7A multiplied by the coefficient in Table 6.

Table6 Coefficient

Pole	Coefficient
1	1
2~3	0.75
4~5	0.6

(12) Leak current

Test method ... Apply 14±0.1V between terminals on PCB mounted connectors. Measure the maximum value of leak current.

(13) Short break monitor

Test method ... Energize all terminals in series and measure dry circuit resistance.

(14) Resistance variation

Test method ... Energize all terminals in series and measure dry circuit resistance.

(15) Insertion force of terminal to the housing

Test method ... Measure the force required to insert terminal into housing completely along the terminal insertion direction at a uniform rate of 25 mm/min.

(16) Terminal/Cavity polarization

Test method ... Insert terminal into housing in incorrect direction.

(17) PCB retention force

Test method ... Clamp wire of PCB mounted connector with JIG at 100mm from the terminal crimp.

Measure the force required to pull out of the terminal along the pulling direction (Fig.2) at a uniform rate of 100 mm/min.

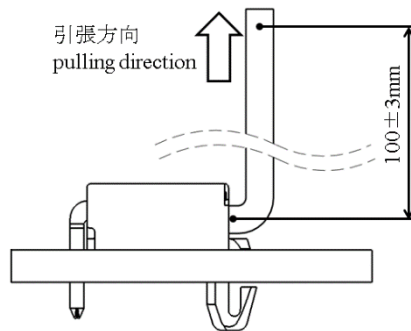

Fig.2 PCB retention force test method

(18) PCB insertion force

Test method ... Insert terminal crimped wire into housing completely.

Measure the force required to insert housing with JIG into PCB along PCB insert direction at a uniform rate of 100 mm/min.

7.2 Environmental Performances Test Method

(1) High temperature aging

Test method ... Place PCB mounted connectors in thermal chamber at $120\pm 3^{\circ}\text{C}$ for 120h.

Remove the connectors from the chamber and leave at the room temperature.

(2) Low temperature aging

Test method ... Place PCB mounted connectors in thermal chamber at $-40_{-10}^{+0}\text{ }^{\circ}\text{C}$ for 120h.

Remove the connectors from the chamber and leave at the room temperature.

(3) Thermal shock

Test method ... Place PCB mounted connectors in thermal chamber and repeat to heat /cold cycle (Fig.3). No. of cycles: 1000

Remove the connectors from the chamber and leave at the room temperature.

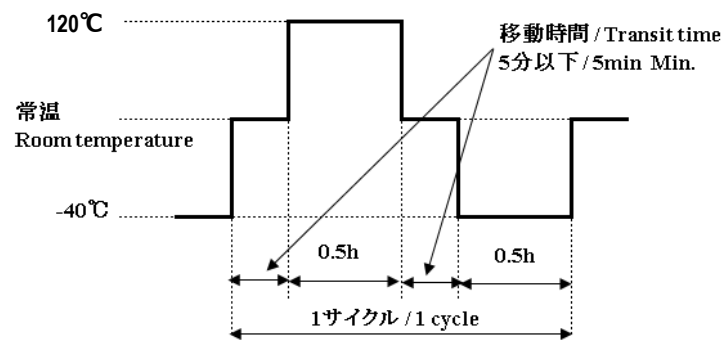

Fig. 3 Thermal shock temperature pattern

(4) Temperature/humidity cycle

Test method ... I) Place PCB mounted connector in climatic chamber and temperature/humidity pattern (22.5h) shown in Fig.4 is performed for 10cycles.

Remove the connectors from the chamber and leave at the room temperature for 2 hours.

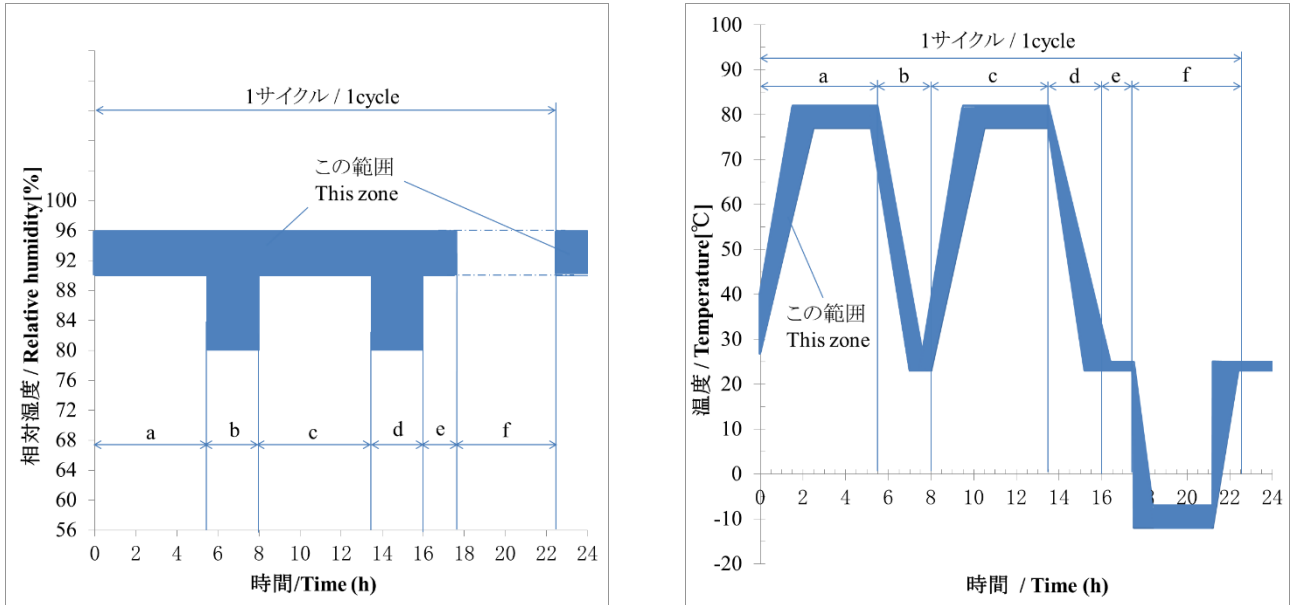

Fig.4 Temperature/humidity cycle I pattern

II) Place PCB mounted connector in climatic chamber and temperature/humidity pattern (24h) shown in Fig.5 is performed for 10cycles.

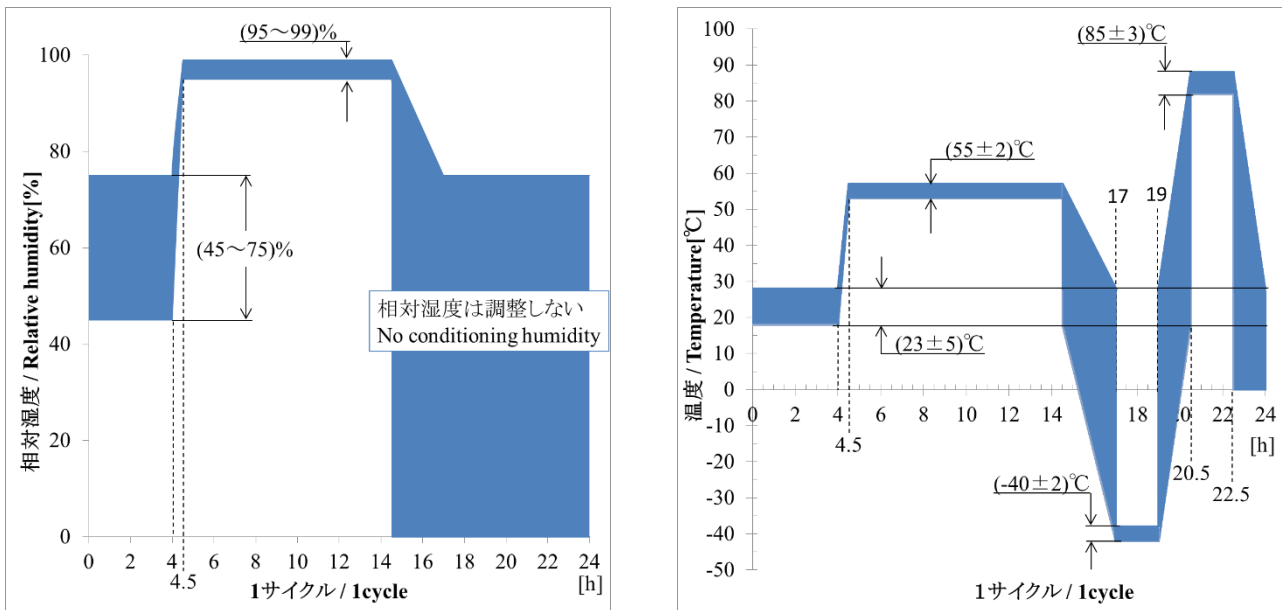

Fig.5 Temperature/humidity cycle II pattern

(5) Humidity

Test method ... Place PCB mounted connector in climatic chamber and subject them to $80\pm 3^{\circ}\text{C}$, $90\sim 95\% \text{RH}$ for 96h.

Hang connectors to prevent any dews developing on the connectors.

Apply voltage of $14\pm 0.1\text{V}$ between each terminal.

(6) Corrosion gas

Test method ... Place terminal crimped wire and terminal crimped wire into housing completely at $25\pm 5\text{ppm}$, $40\pm 2^{\circ}\text{C}$, $90\sim 95\% \text{RH}$, SO_2 gas for 96h.

(7) Mechanical vibration

Test method ... I)Fix PCB mounted connector shown in Fig.6 on fixture and subject them to vibration under the following conditions.

◎Vibration condition

- Direction: 3 (front-back, left-right, up-down)
- Acceleration: 88m/s^2
- Duration: 3h(front-back, left-right, up-down)
- Frequency: 20-200Hz
- Sweep time: 3min (per sweep)

Energize all terminals in series under the following 2 conditions during the test.

[open 12V, short circuit: multiply 7A and coefficient in Table6.]

[open 20mV, short circuit 10mA MAX.]

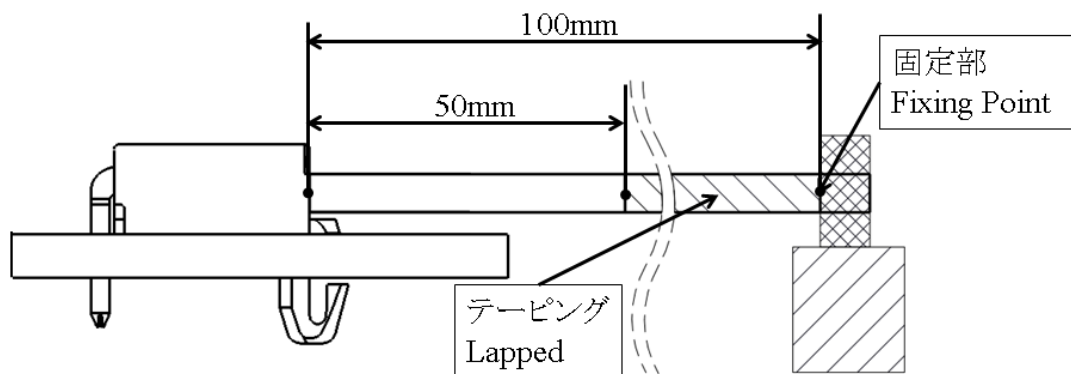

Fig.6 Mechanical vibration, Mechanical shock, Vibration with temperature change test condition

II) Fix PCB mounted connector and subject to vibrate under the following conditions.

Directions: 6 (front-back, left-right, up-down)

Energize all terminals in series.

Monitor resistance during test with the following supply current

Terminal should be half-lapped with tape starting from the position of

500mm from the tip of the terminal.

◎Vibration condition

- Acceleration : 43.1m/s²
- Frequency : 20~400Hz
- Sweep time : 6min (per sweep)
- Supply current : 1A

(8) Mechanical shock

Test method ... I)Fix PCB mounted connector and subject to impact under the following conditions.

Impact is based on Fig.7 Sinusoidal half-wave.

Duration $D=6\text{ms}$, Peak acceleration $A=981\text{m/s}^2$

Directions: 6 directions (front-back, left-right, up-down) 3 shocks each direction

Energize all terminals in series.

Monitor resistance during test, open circuit $20\pm 5\text{mV}$, short circuit $10\pm 0.5\text{mA}$.

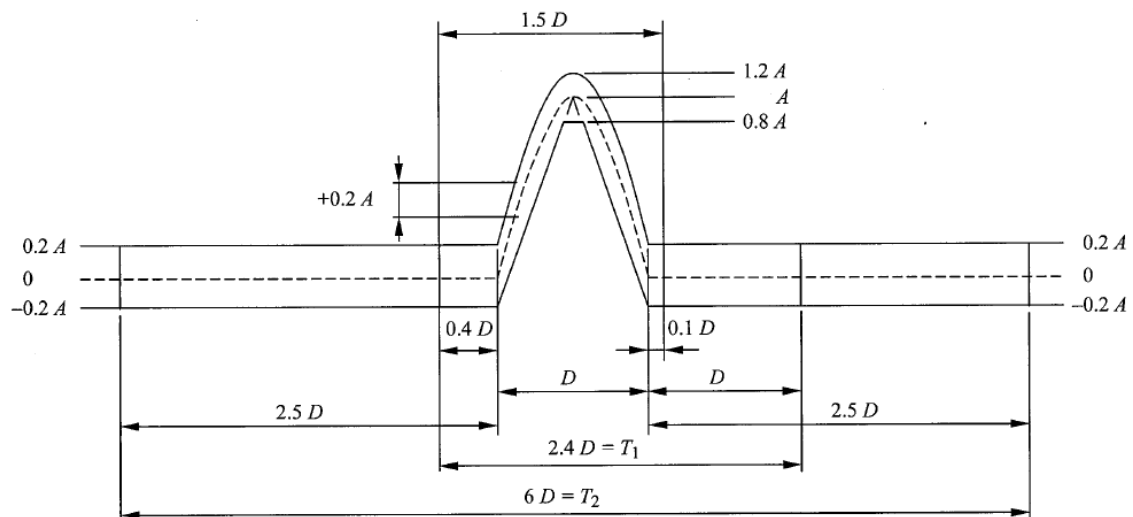

Fig.7 Sinusoidal half-wave

II) Fix mated connectors and subject to impact in vertical (up-down) directions.

Duration 1h open circuit 13V, short circuit 10mA.

Impact with cam drop 3.2mm, 750r.p.m.

Monitor conductivity or non-conductivity in over 10μ during the test.

(9) Overcurrent

Test method ... PCB mounted connector are laid horizontally in windless condition, and subjected to current for one.

The current has shown as below. (See Table 7)

Table7 Supply current

Sample No.	Current [A]	Time
1	11.0	60 min.
2	13.5	10 sec.
3	15.0	5 sec.
4	20.0	1 sec.

(10) Vibration with temperature change

Test method ... Fix PCB mounted connector shown in Fig.6 on fixture and subject them to vibration at $100\pm 3^{\circ}\text{C}$.

◎Vibration condition

- Acceleration: 88m/s^2
- Frequency: 20-200Hz
- Sweep time: 3min (per sweep)

Energize all terminals at current in Table8 for 45min, break for 15min.

No. of cycles: 300.

Perform the test at three directions (front-back, left-right, up-down) individually.

Monitor resistance during current in Table8.

After test, carry out vibration test with 3 axes, each for 1h. Check for any short breaks.

Table8 Supply current

Pole	Current [A]
2	2.18
3	1.99
4	1.83
5	1.54

(11) Condensation

Test method ... Place PCB mounted connector in climatic chamber and subject them to the following cycle.

1 cycle: 1h at $-40\pm 3^{\circ}\text{C}$, then 1h at $25\pm 3^{\circ}\text{C}$ and $90\pm 5\%RH$

No. of cycles: 48.

(12) Rush current

Test method ... Energize all terminals in series at 60°C and carry out a) and b).

- a) Apply twice as large as rated current (3A) to connector for 1 min., break for 9 min.

No. of cycles: 1000

- b) Apply five times as large as rated current (3A) to connector for 10 sec., break for 590 sec.

No. of cycles: 1000

(13) High temperature operability

Test method ... Place terminal and housing at $80\pm 3^{\circ}\text{C}$ for 1 hour. After 60 sec. at the room temperature, then insert terminal into housing.

(14) Resistance to stress corrosion

Test method ... Degrease terminals, cleanse with 10% H_2SO_4 , rinse under water and dry.
Submerge in solution of free ammonia 6N, copper 10.2g/L for 3h, then remove.

(15) Current cycle

Test method ... Energize all terminals in series with current value in Table9 for 45min, then break for 15min. (Choose the current value at 70°C of temperature rise.)
No. of cycles:1000.

Table 9 Supply current

Pole	Current[A]
2	9.89
3	8.86
4	8.26
5	7.75

(16) Sulfur dioxide gas

Test method ... Place PCB mounted connector in chamber at $40\pm 2^{\circ}\text{C}$ 、90-95% RH、10ppm SO_2 gas for 24h.
Then put it out from the chamber and leave to recover to the room temperature.