

ISH® VW CONNECTOR

Instruction Manual

1	RS0789	January 6, 2021	H. Naoi	S. Tono	E. Kawabe
0	RS0615	August 7, 2019	H. Naoi	J. Tateishi	E. Kawabe
Rev.	ECN	Date	Prepared by	Checked by	Approved by

Contents

1. Purpose	• • • • •	Sheet 3
2. Applicable items	• • • • •	Sheet 3
3. Crimping procedure	• • • • •	Sheet 4
4. Terminal insertion	• • • • •	Sheet 14
5. Secondary lock installation	• • • • •	Sheet 15
6. How to release secondary lock	• • • • •	Sheet 18
7. How to release terminals	• • • • •	Sheet 20
8. Mating of connector	• • • • •	Sheet 24
9. Unmating of connector	• • • • •	Sheet 25
10. Handling of Product	• • • • •	Sheet 26
11. Storage of housings and terminals	• • • • •	Sheet 28
12. Jig	• • • • •	Sheet 28
13. Other notes	• • • • •	Sheet 29
14. Contact	• • • • •	Sheet 29

1. Purpose

The Manual explains the handling of ISHVW CONNECTOR.

2. Applicable items

The Manual is applicable to the items listed below.

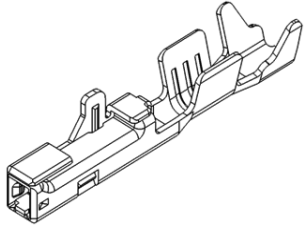
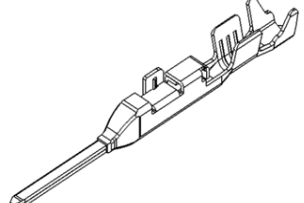
Name	Part No.	Image
FEMALE TERMINAL	VT001-512	
MALE TERMINAL	VT002-012	

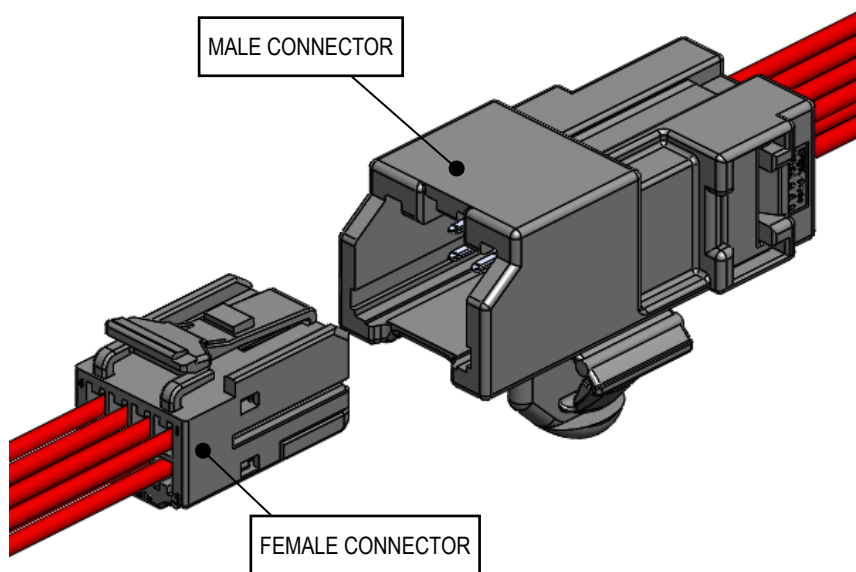

Fig.1 Product summary

3. Crimping procedure

3-1. Applicable wires

Terminal Type	Terminal Parts No.	Applicable Wire
FEMALE TERMINAL	VT001-512	Wire size : 0.3mm ² , 0.5mm ² Insulation outer diameter : φ 1.60mm MAX.
MALE TERMINAL	VT002-012	

3-2. Wire strip length

- ① Strip the insulation off by 3.0±0.1mm (see Fig.2)
- ② Check to see that there is no damage to the conductors or insulation, cut off conductors, short conductors and deformed conductors as shown in Fig. 3.

Do not use wires with damaged conductors, cut off conductors, short conductors and deformed conductors.

Using faulty wires may cause crimping problems.

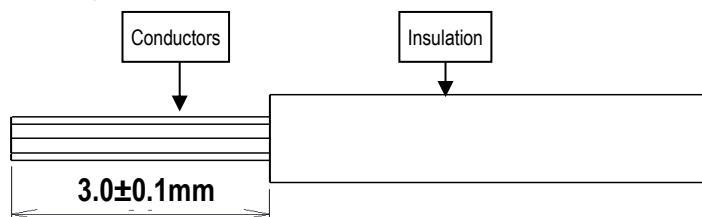

Fig.2 Wire strip

Condition	Image
Good	
Damaged conductors (defect)	
Cut off conductors (defect)	
Deformed conductors (defect)	

Fig.3 Wire strip(Unacceptable examples)

3-3. Terminal part names

3-3-1. Female terminal

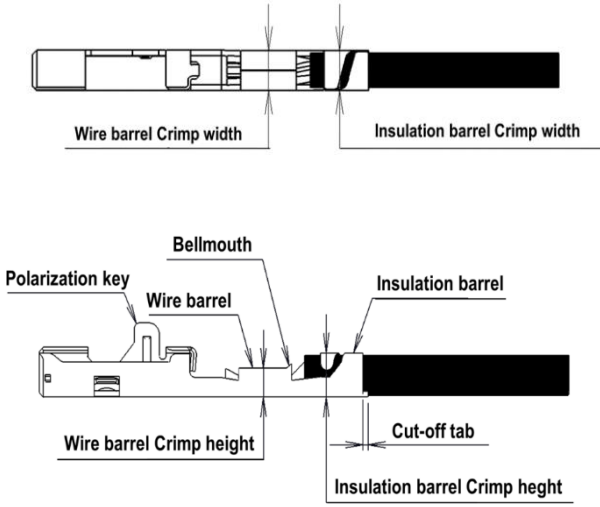

Fig.4 Female terminal part names

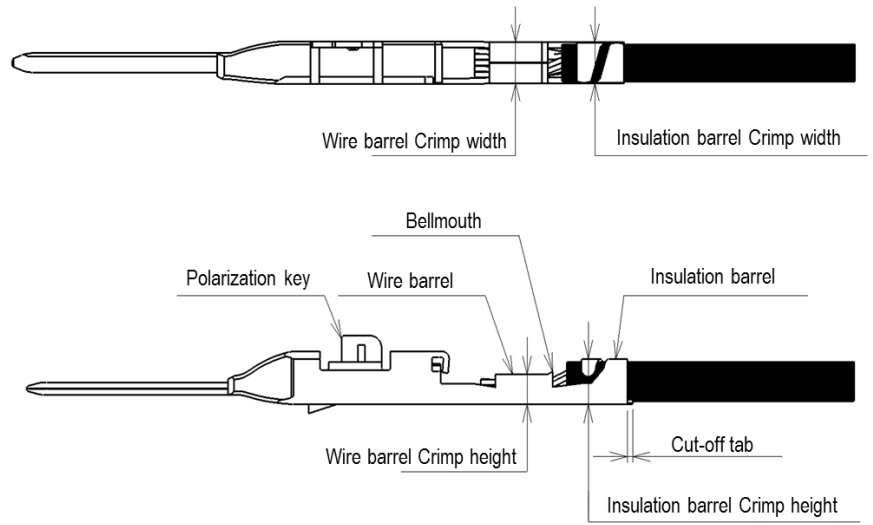

Fig.5 Male terminal part names

3-4. Crimping requirements

Crimp dimension

Crimped terminals must satisfy the crimp dimension specified in Table 1.

Table 1 Crimp dimension

Terminal Part No.	Wire size	Insulation outer diameter	Wire barrel crimp height	Wire barrel crimp width	Insulation barrel crimp height	Insulation barrel crimp width
VT001-512 VT002-012	0.3mm ²	φ1.60mm MAX.	0.90±0.05 (※)	1.40±0.04	1.60+0.1/-0.05	1.55±0.05
	0.5mm ²		0.95±0.05 (※)		1.80±0.05	

※Crimp dimensions may be different depending on conductor construction of the wire.

Please contact our Sales Department shown in 14(sheet 29) about wire used, then we will verify it and notify you the appropriate crimp dimensions.

Measuring method for crimp dimension is described below.

Use the micrometer shown in Fig.6 for measurement of each part.



Fig 6. Micrometer

(1)-1. Measuring method for wire barrel crimp height is described below.

To measure the wire barrel crimp height, pinch the top of the wire barrel (winding side) and the bottom of the wire barrel with a micrometer. (see Fig.7)

Secure terminals firmly to obtain accurate measurement.

Do not pinch the bell mouth. The wire barrel crimp height can not measure accurately.

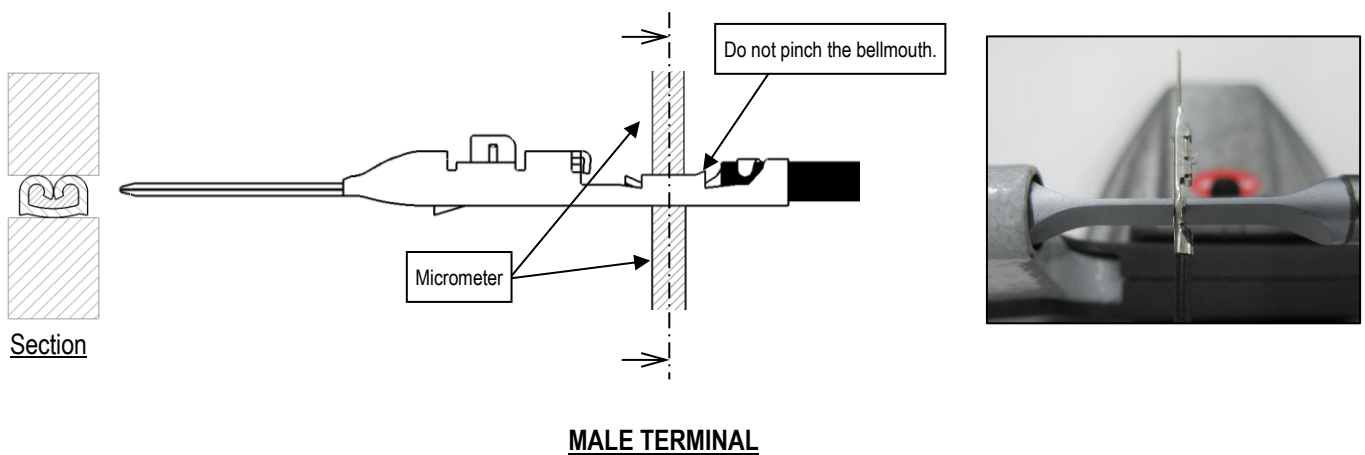
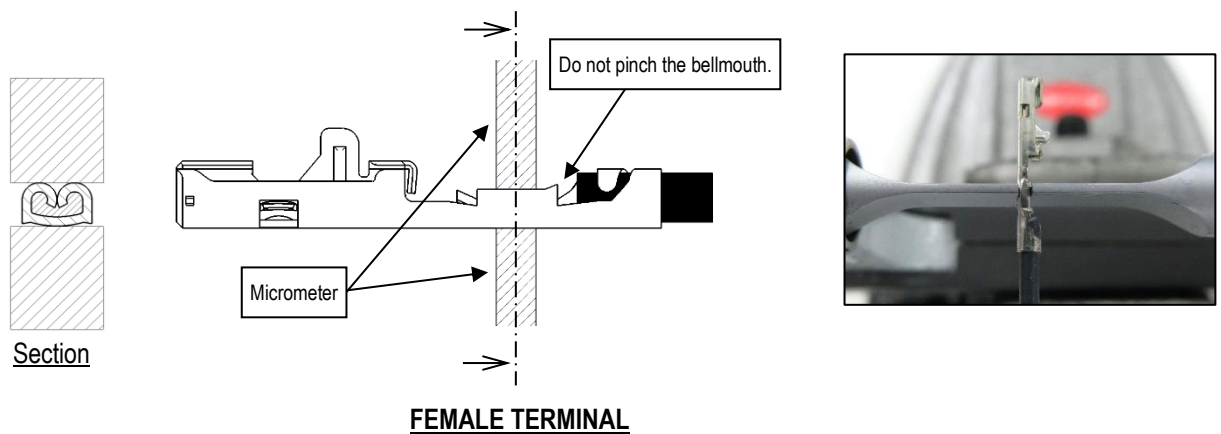

Fig 7. Wire barrel Crimp height measurement

(1)-2. Measuring method for insulation barrel crimp height is described below.

To measure the insulation barrel crimp height, pinch the top of the insulation barrel (winding side) and the bottom of the insulation barrel with a micrometer. (see Fig.8)

Secure terminals firmly to obtain accurate measurement.

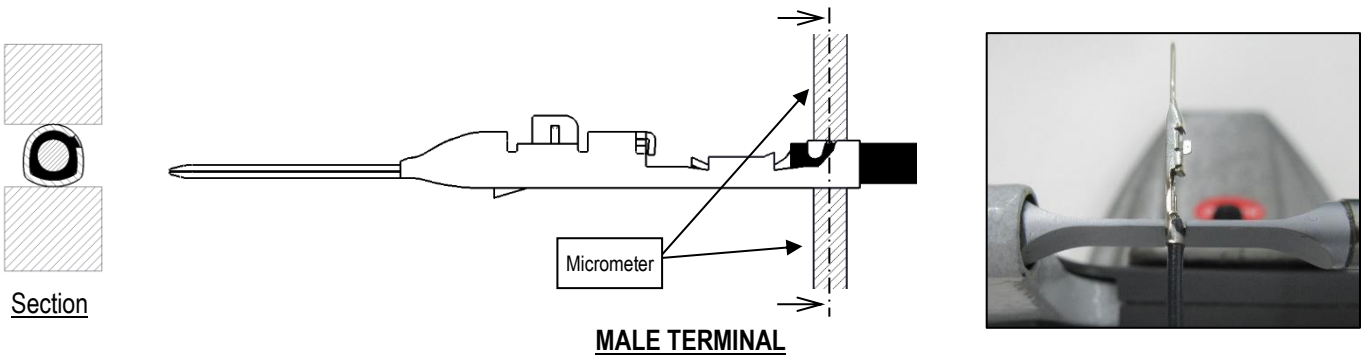
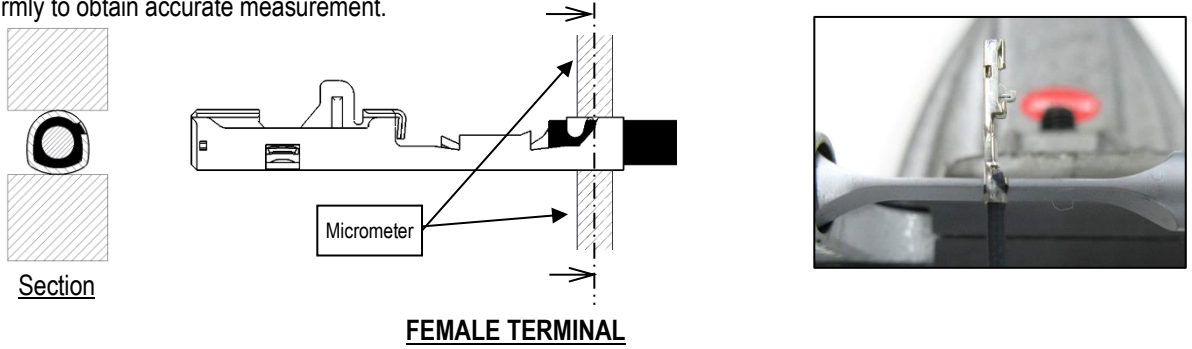

Fig 8. Insulation barrel Crimp height measurement

(1)-3. Measuring method for wire barrel crimp width is described below.

To measure the wire barrel crimp width, pinch the side of the wire barrel with a micrometer. (see Fig.9)

Secure terminals firmly to obtain accurate measurement.

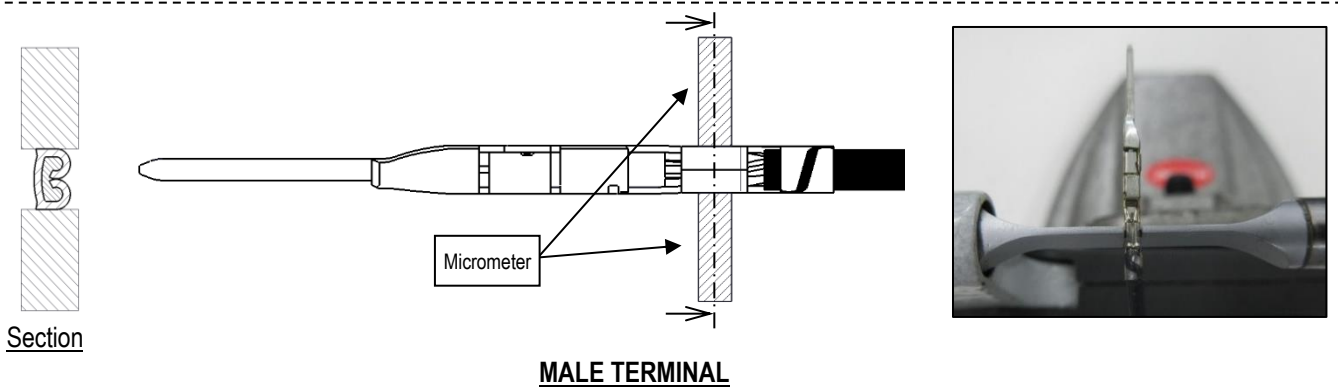
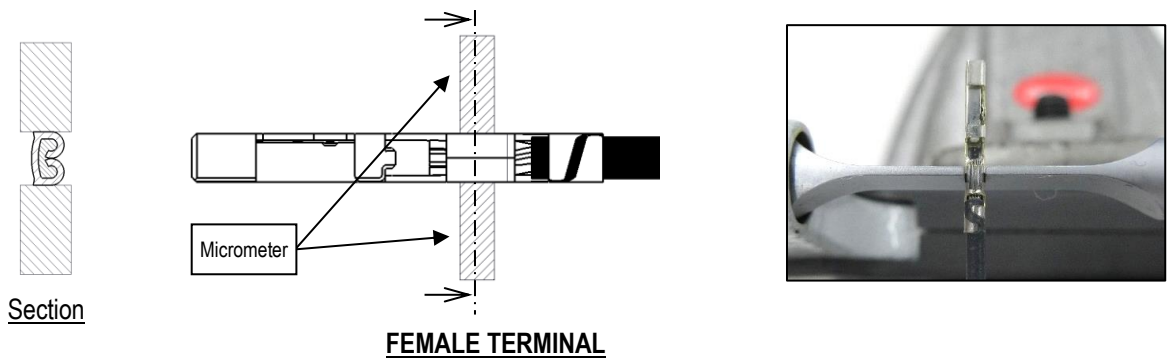

Fig 9. Wire barrel crimp width measurement

(1)-4. Measuring method for insulation barrel crimp width is described below.

To measure the insulation barrel crimp width, pinch the side of the insulation barrel with a micrometer. (see Fig.10)

Secure terminals firmly to obtain accurate measurement.

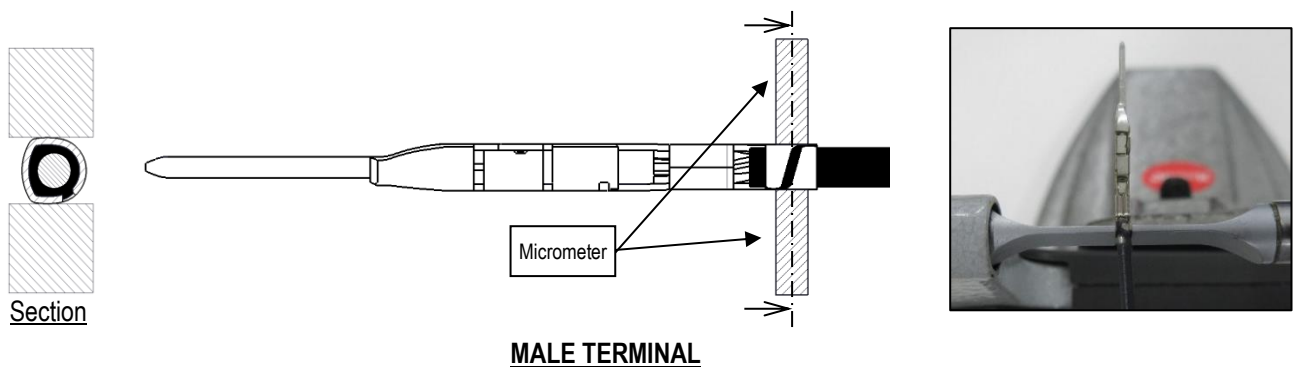
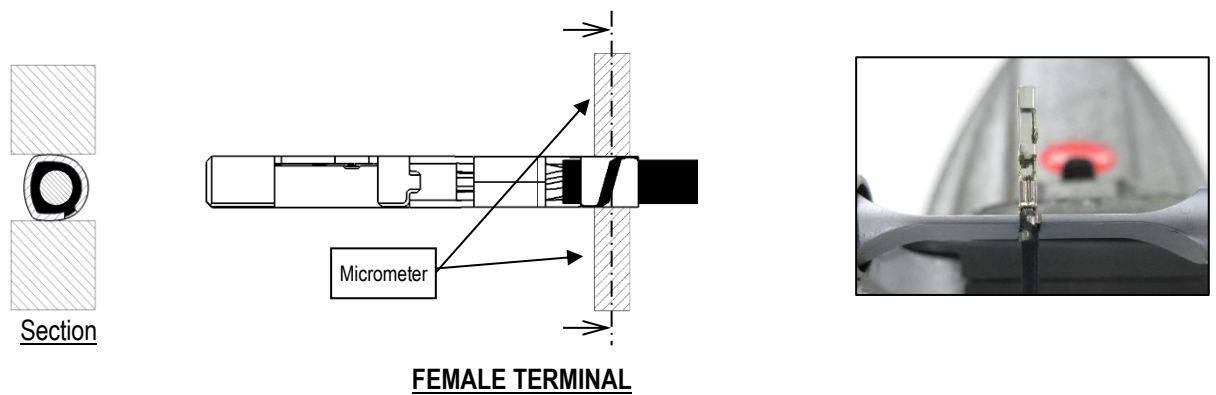

Fig 10. Insulation barrel crimp width measurement

(2) Bottom burrs

Burrs produced during crimping process must not extend beyond the bottom surface. (see Fig.11)

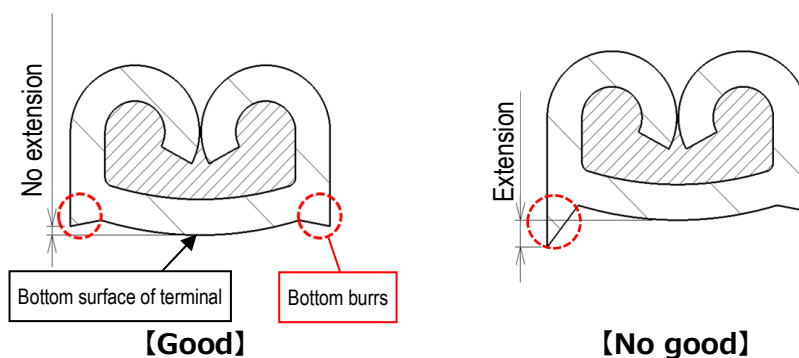
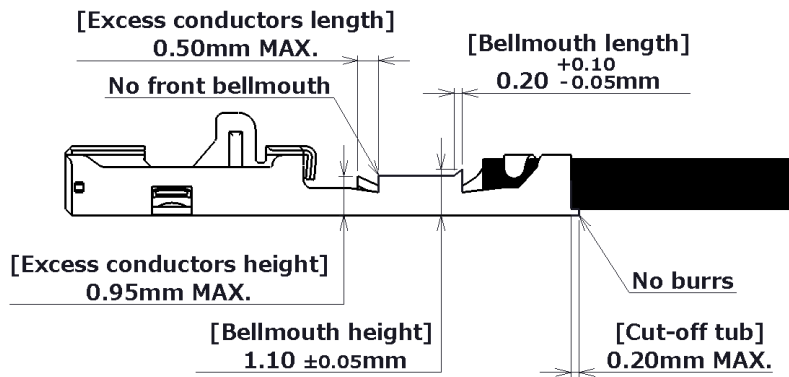

Fig 11. Bottom burrs

③ Bellmouth, excess conductors and cut-off tab

Bellmouth, excess conductors and cut-off tab must satisfy the dimensions shown in Fig. 12.



FEMALE TERMINAL

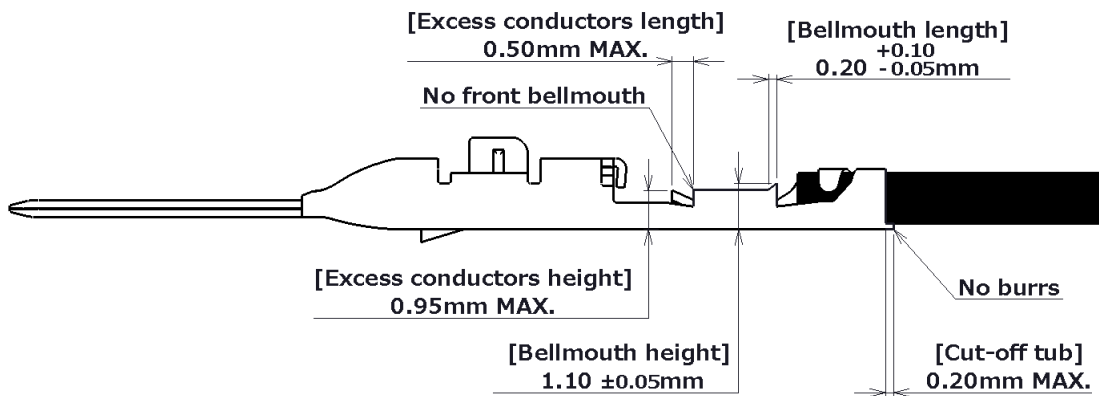

MALE TERMINAL

Fig.12 Bellmouth, excess conductors and cut-off tab

④ Unaligned wire barrel ends

Unaligned wire barrel ends is 0.1mm MAX..(see Fig.13)

※If wire barrel ends are not aligned, resulting in different dimension of excess conductors or bellmouth between the sides , dimensions must be measured on larger side and be satisfied.

(In the case shown in Fig.14, measure excess conductors:[a],bellmouth:[b].)

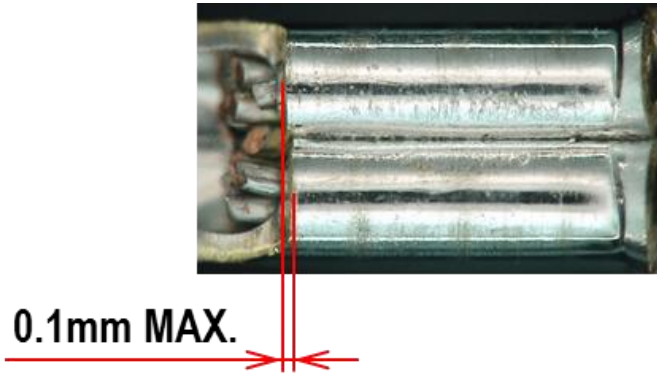

Fig.13 Unaligned wire barrel ends

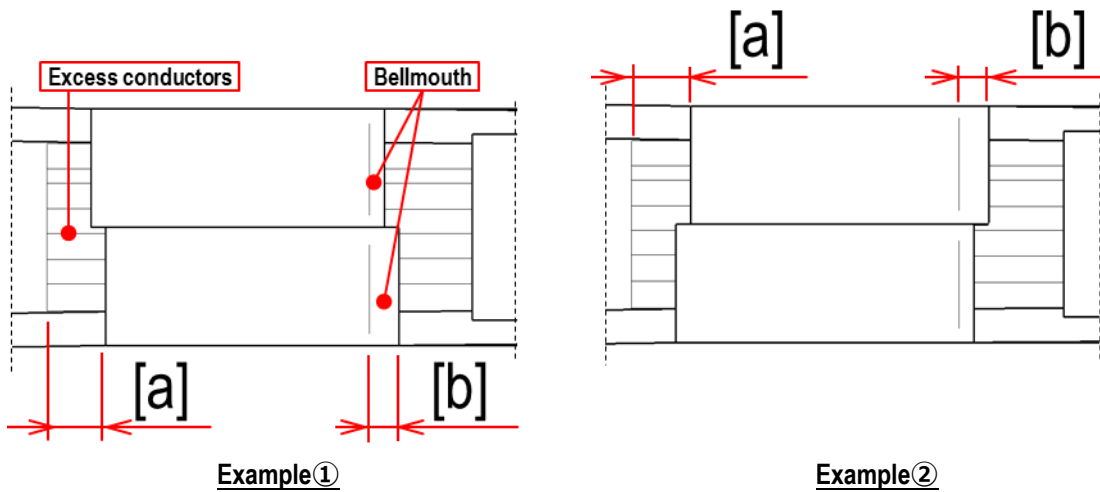

Fig 14. Example of unaligned wire barrel ends

⑤ Rolling

Rolling is 3°MAX. from the wire barrel (baseline).(see Fig.15)

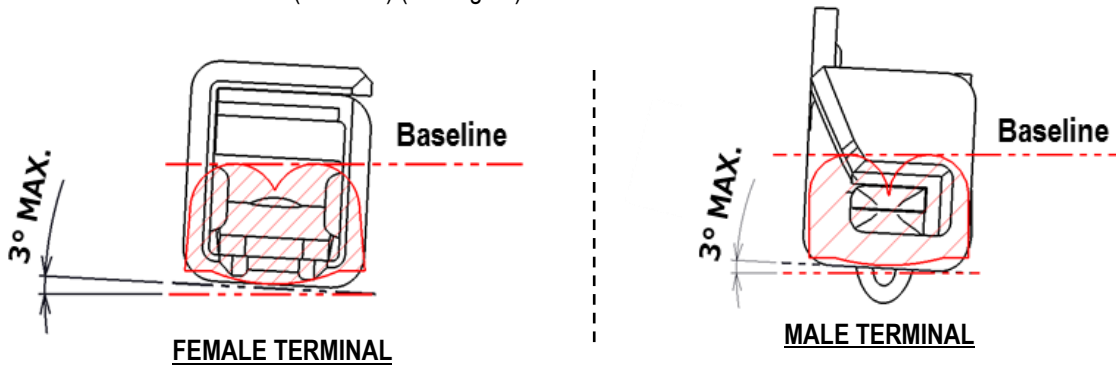

Fig.15 Rolling

⑥ Terminal twist

Terminal twist is 1.2°MAX. from the baseline, i.e. the box (baseline). (see Fig.16)

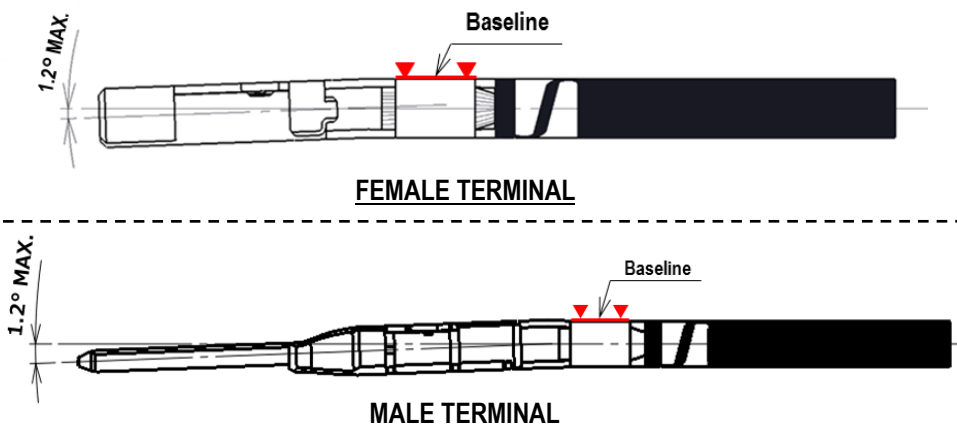

Fig.16 Twist terminal

⑦ Bend up and bend down

Bend up is FEMALE TERMINAL:1.9mmMAX. , MALE TERMINAL:1.1mmMAX..

Bend down is not allowed. The height is from the wire barrel(baseline) to the terminal measurement point. (see fig. 17 and 18)

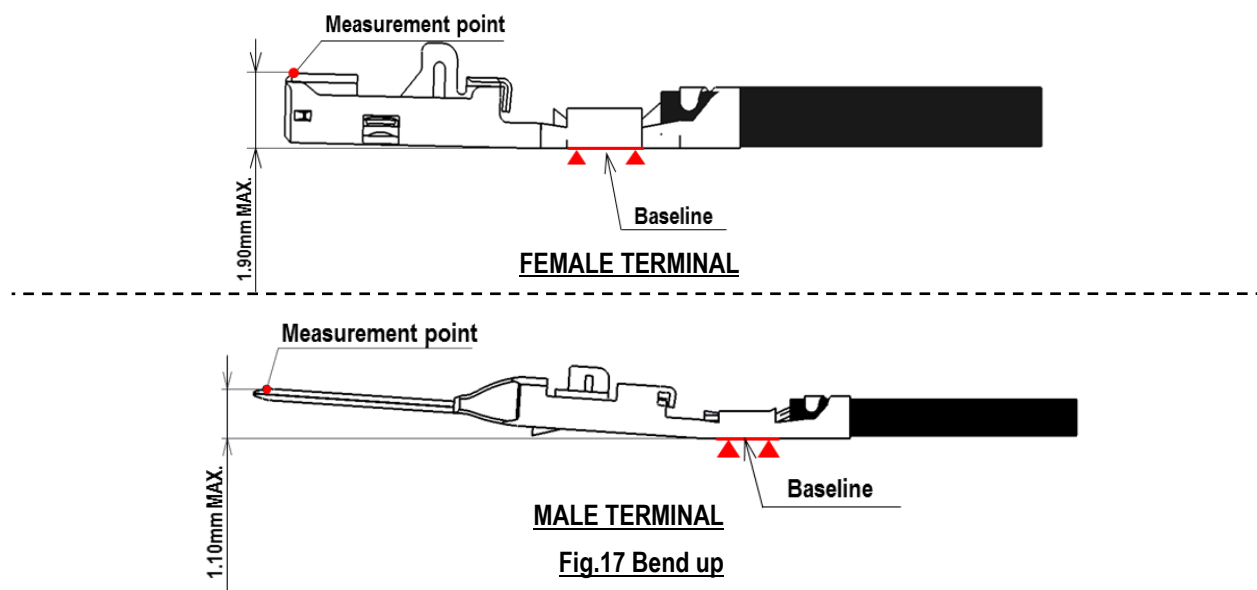
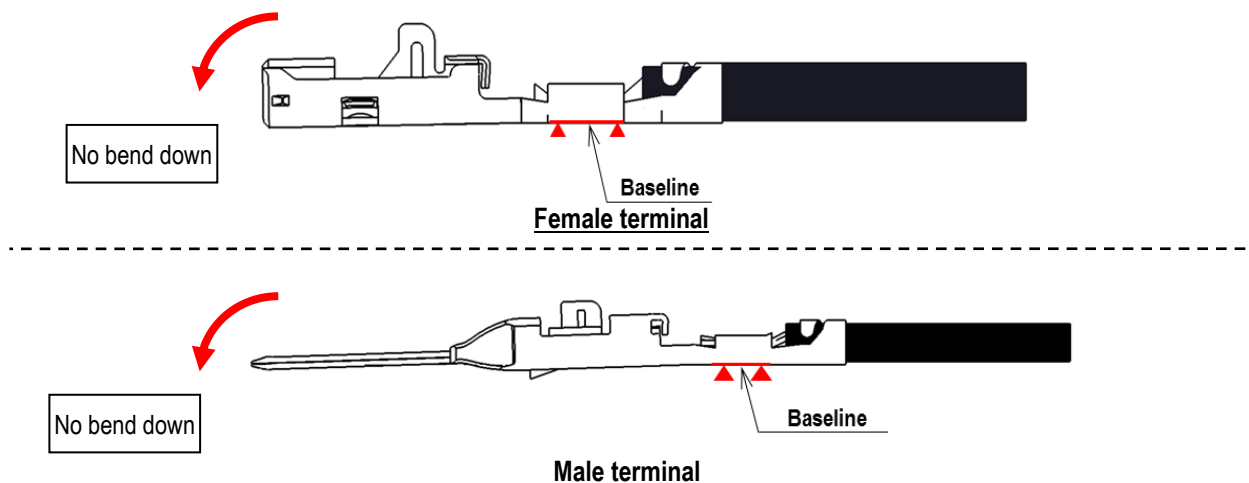

Fig.17 Bend up



Male terminal
Fig.18 Bend down

3-5. Defective criteria

Terminals with the following conditions are deemed defective.

① No rear bellmouth

Rear bellmouth is not formed. (see Fig.19)

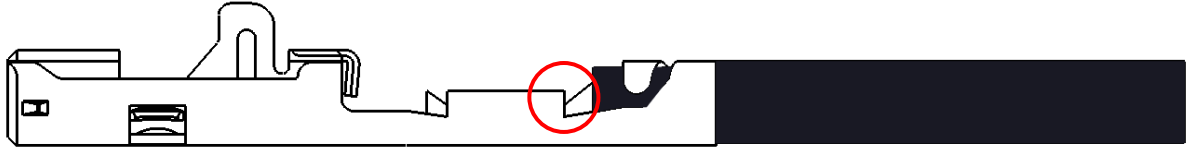

Fig.19 No rear bellmouth

② Insufficient conductors insertion

Conductors are insufficiently inserted into the wire barrel. (see Fig.20)

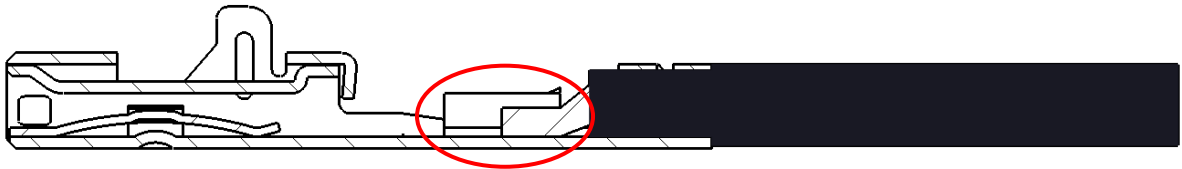

Fig.20 Not fully inserted conductors into wire barrel

③ Excessive conductors out

Excess conductors protrude from the wire barrel and does not satisfy the dimension in Fig.12 of sheet 9. (Fig.21)

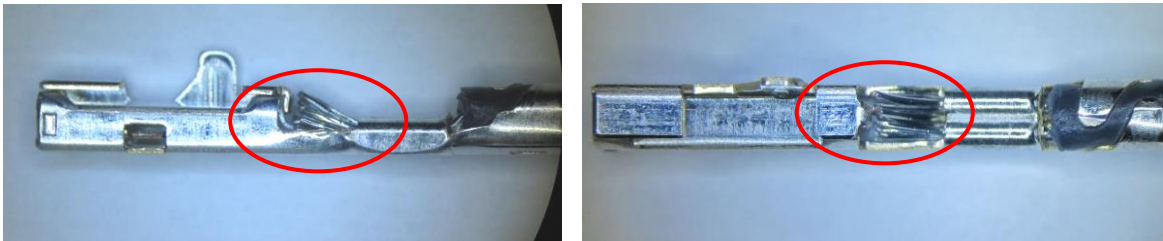

Fig.21 Excessive conductors out

④ Incomplete conductors crimping

Conductors are not crimped inside the wire barrel, or within the terminal. (see Fig.22)



Fig.22 Incomplete conductors crimping

⑤ Incomplete insulation crimping

Strip length is too short and insulation is crimped inside the wire barrel (see Fig.23).

Strip length is too long and insulation does not fit completely inside the insulation barrel (see Fig.24).

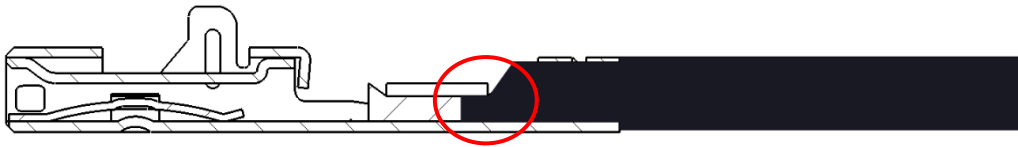

Fig.23 Strip too short

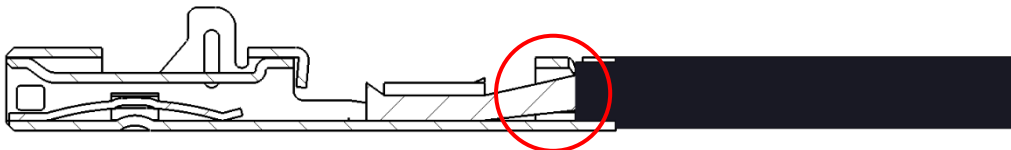

Fig.24 Strip too long

(6) Torn insulation

Insulation is torn by insulation barrel. (see Fig.25)

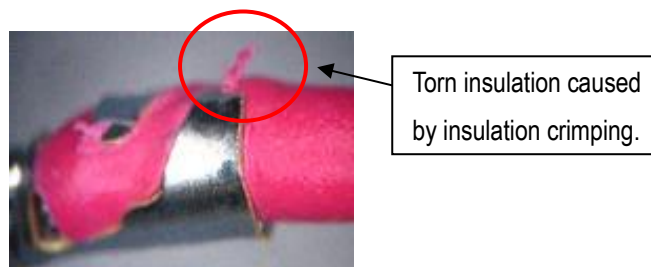

Fig 25. Torn insulation

4. Terminal insertion

- ① Ensure that the terminal is crimped correctly and there is no damage, deform or dirt present.
- ② Hold the wire to insert the terminal as shown in Fig.26.
- ③ Insert the terminal into the corresponding corehole of the housing, as deeply as possible, in the orientation as shown in Fig. 26.
- ④ Once the terminal is inserted, ensure that the terminal retention is fastened by pulling the wire lightly towards you.

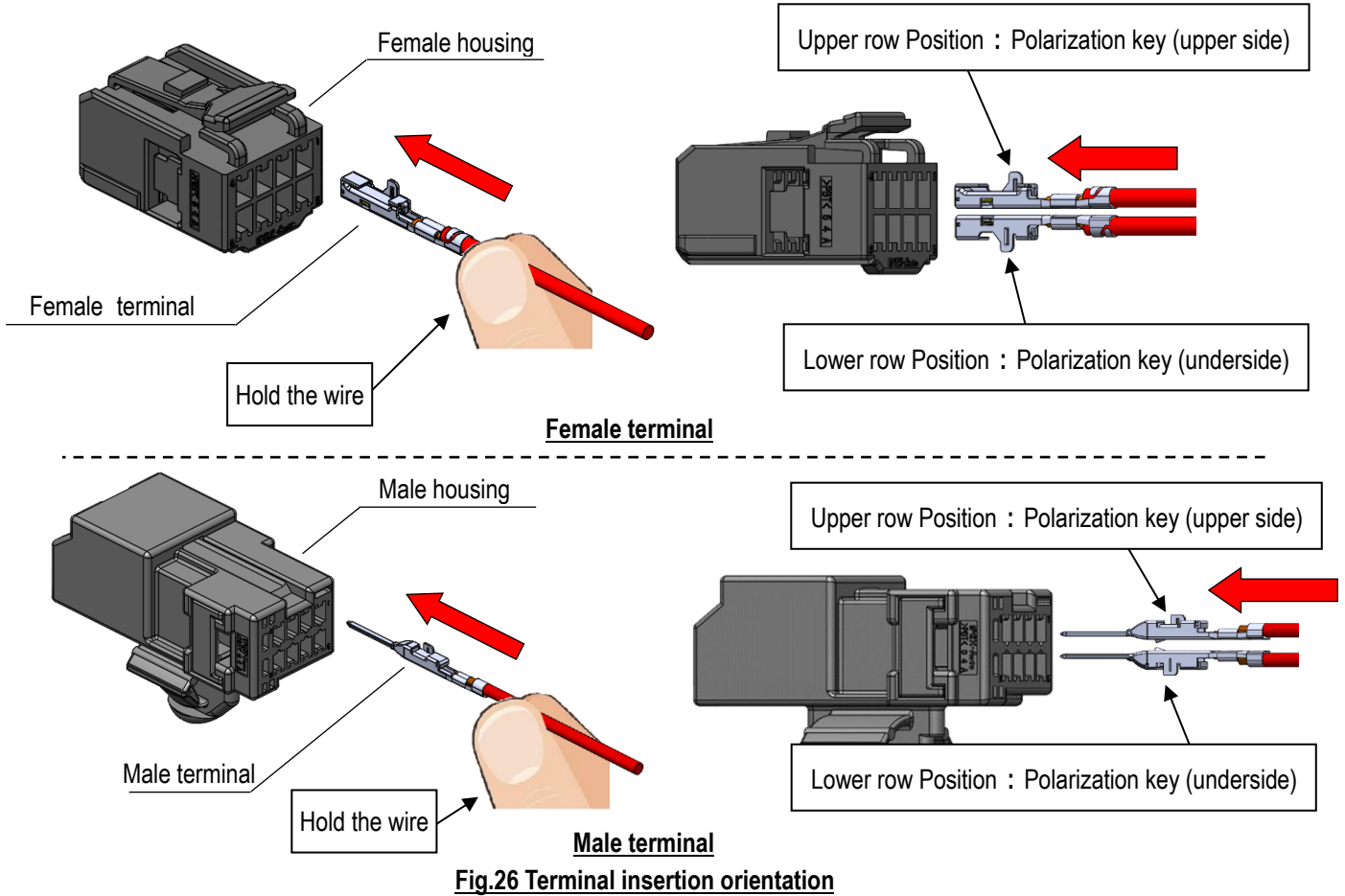

Fig.26 Terminal insertion orientation

Notes:

- ① Terminals must be inserted in the orientation instructed. Forcibly inserting terminals in any other orientation may result in damage or deformation. Terminal can not be inserted in the incorrect orientation. (see Fig.27)
- ② Once the terminal is inserted, do not apply excessive pulling force to the wire.

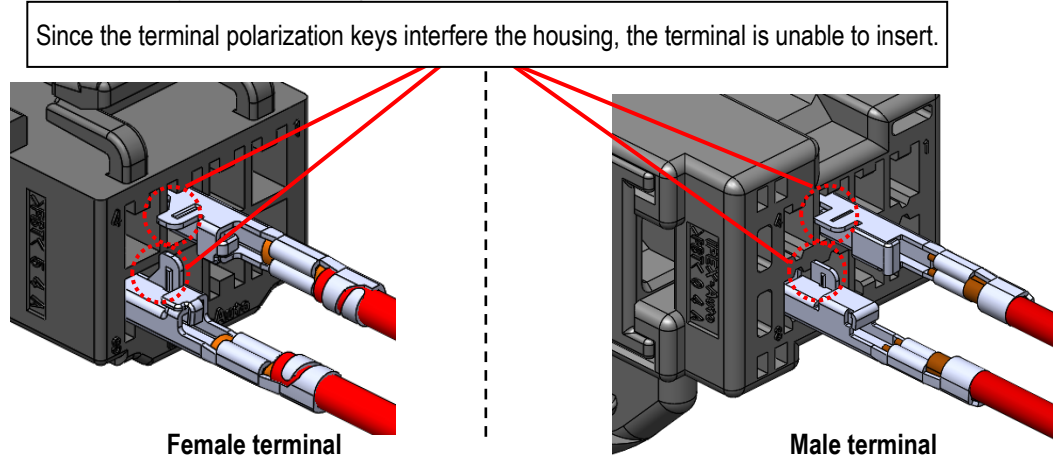

Fig.27 Orientation of incorrect terminal insertion

5.Retainer installation

5-1.Female connector

①After female terminal insertion is complete, install the female retainer.

You will hear audible click when the female retainer is engaged properly.

②Check that the female retainer is pushed in completely, i.e. aligned with the sidewall of the female housing.

When the female retainer cannot be pushed in completely, do not push forcefully.

Check that the female terminals are inserted correctly and sufficiently, and repeat the insertion procedure in 4.

Insert all the female terminals properly, and push the female retainer until audible click is heard.

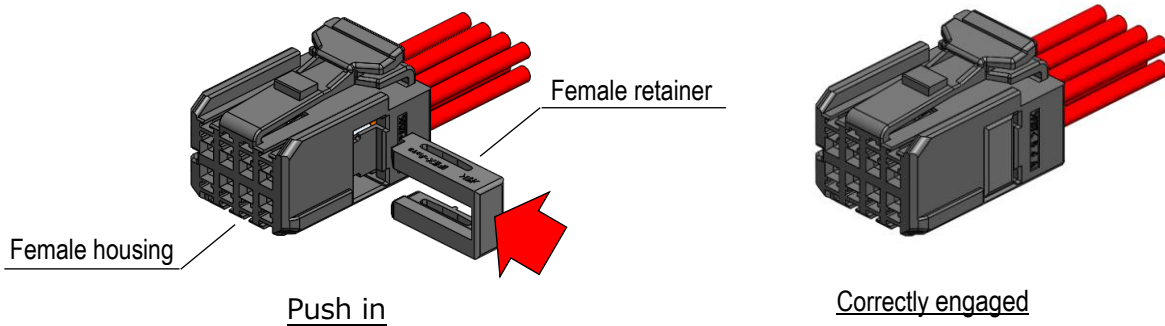
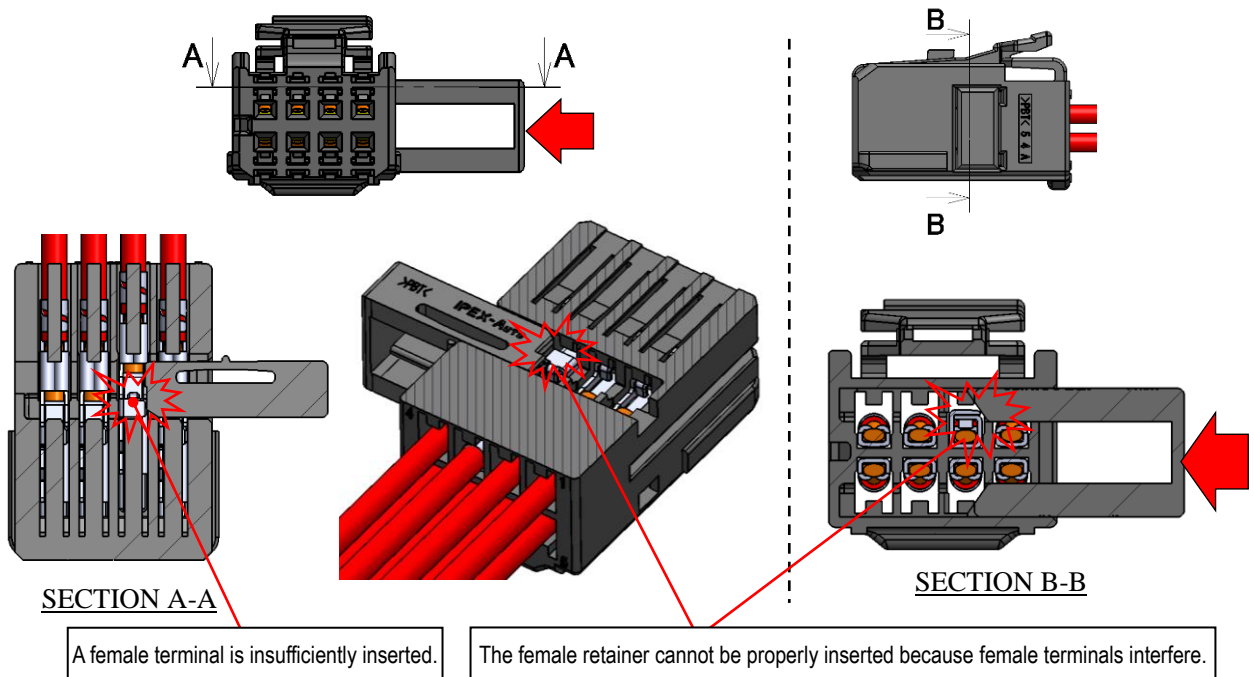

Fig.28 Installation of retainer

③When female terminal(s) is/are insufficiently inserted as shown in Fig.29, the female retainer cannot be installed.

Insert the female terminal(s) completely, and install the female retainer again.



A female terminal is insufficiently inserted.

The female retainer cannot be properly inserted because female terminals interfere.

Fig.29 Insufficient female terminal insertion

- ④ Do not forcefully insert in any other position than those shown in Fig.30.

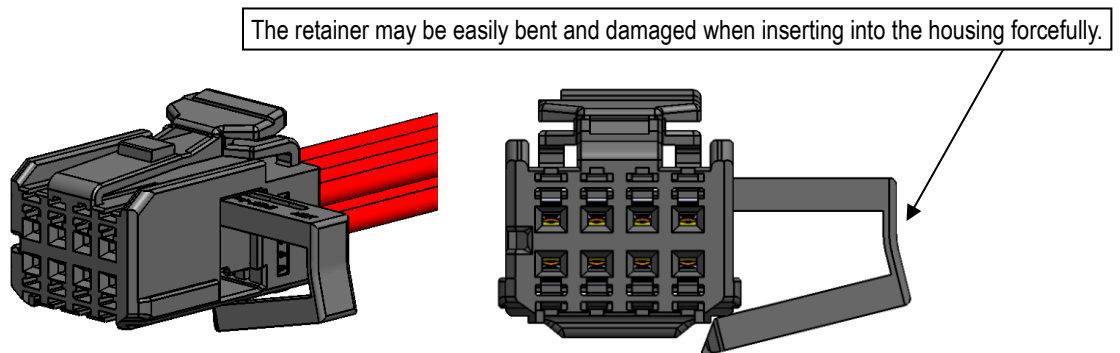

Fig.30 Insufficient retainer installation

- ⑤ The female retainer cannot be inserted, when it is inserted in incorrect orientation to the female housing, as shown in Fig.31.

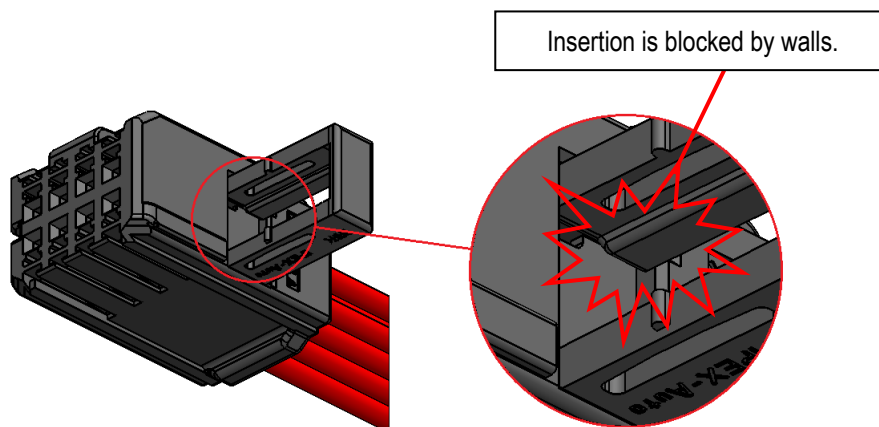

Fig.31 Incorrect retainer installation

Notes

- ① The female retainer must be inserted in the orientation instructed.
Inserting retainer in any other orientation may result in damage or deformation. (see Fig.30,31)
- ② If there is any damage or deformation, do not use the damaged item. Replace the item with a new one.

5-2. Male connector

- Make sure that the male retainer protrudes from the side of male housing surface before inserting the male terminal into the male housing. If the male retainers are engaged with the male housing, pay attention not to deform the male housing, and release the male retainer by the method in 6-2 (sheet 19).

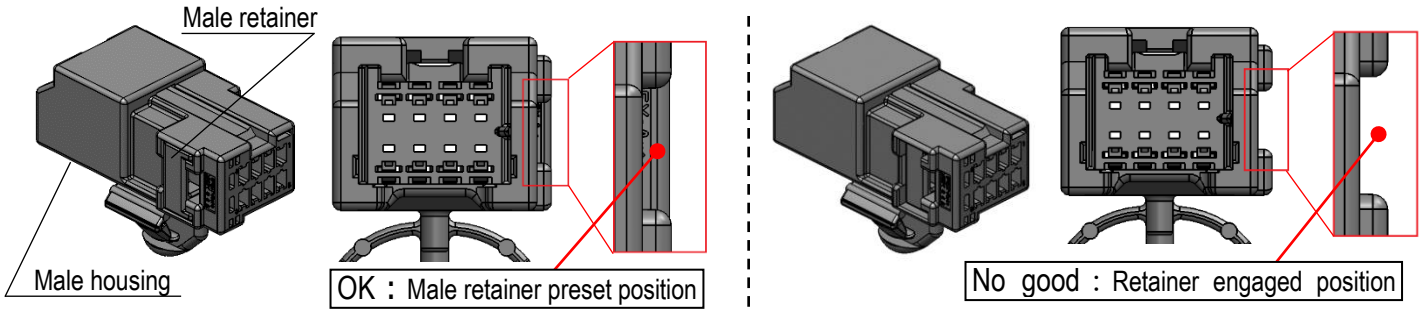

Fig.32 Checkpoint before engaging male retainer and the male housing.

- Push the male retainer perpendicularly to the male housing as shown in Fig.33 after male terminal insertion is complete. You will hear audible click when the male retainer is engaged properly.
- Check that the male retainer is completely pushed, i.e. aligned with the side surface of the male housing. Do not push the male retainer forcefully when it cannot be completely pushed. Check that the male terminals are inserted correctly and sufficiently, and repeat the insertion procedure in 4 (sheet 14). Insert all the terminals properly, and push the male retainer until audible click is heard.

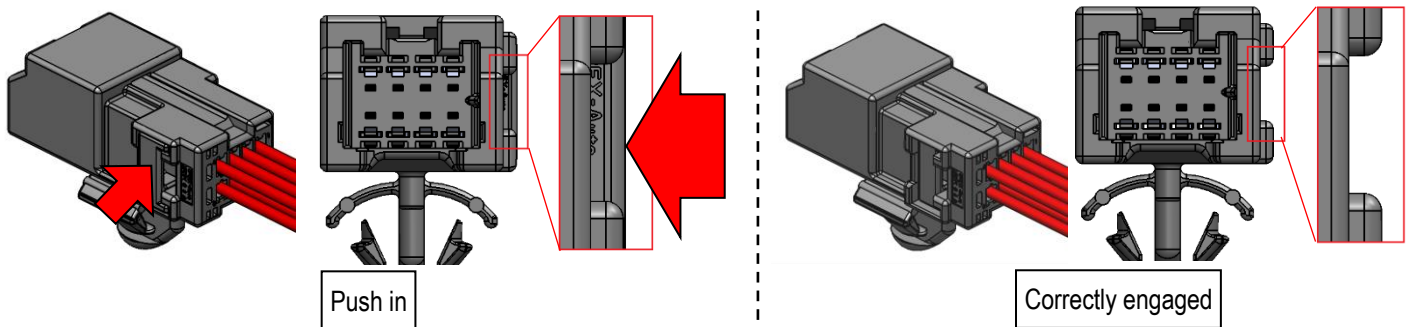

Fig.33 Installation of Retainer

- When male terminals are insufficiently inserted as shown in Fig.34, the male retainer cannot be installed. Insert the male terminals completely, and install the male retainer again.

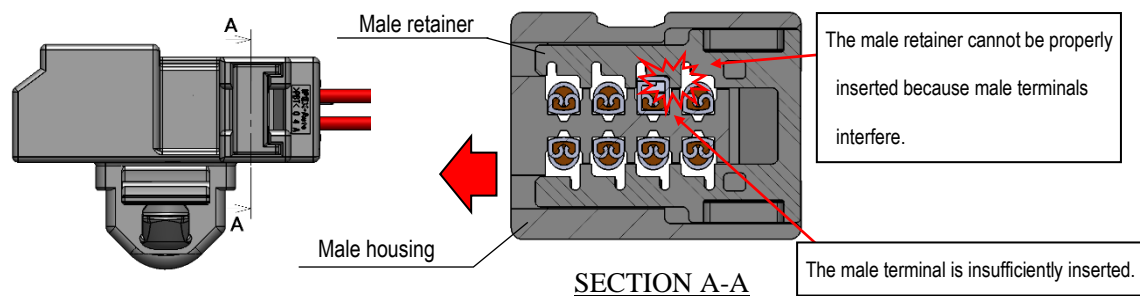

Fig.34 Insufficient male terminal insertion

Notes

- If there is any damage or deformation, do not use the damaged item. Replace the item with a new one.

6.How to release the retainer

6-1.Female connector

- ① Place the female retainer releasing jig into the releasing apertures situated on the side of the housing (Pos.1side), and push out the retainer (see Fig.35).

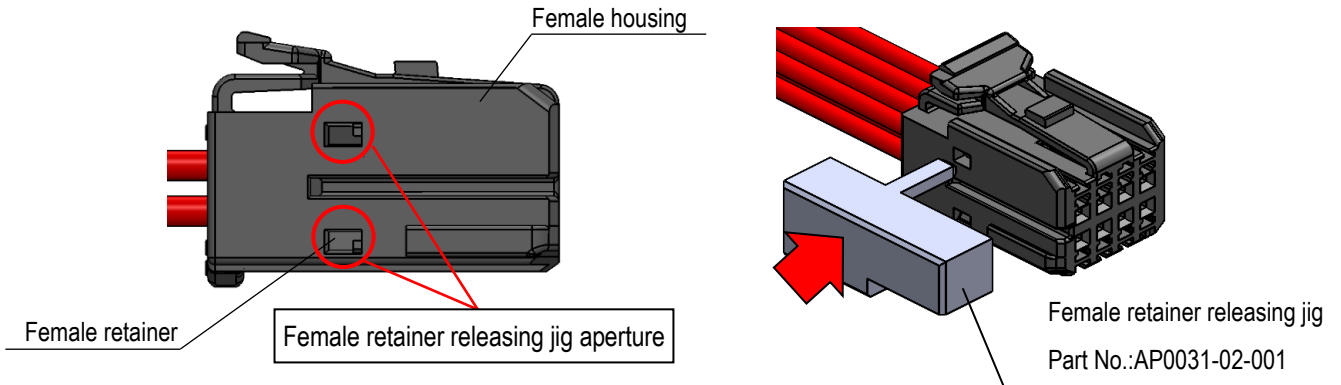

Fig.35 How to release the female retainer

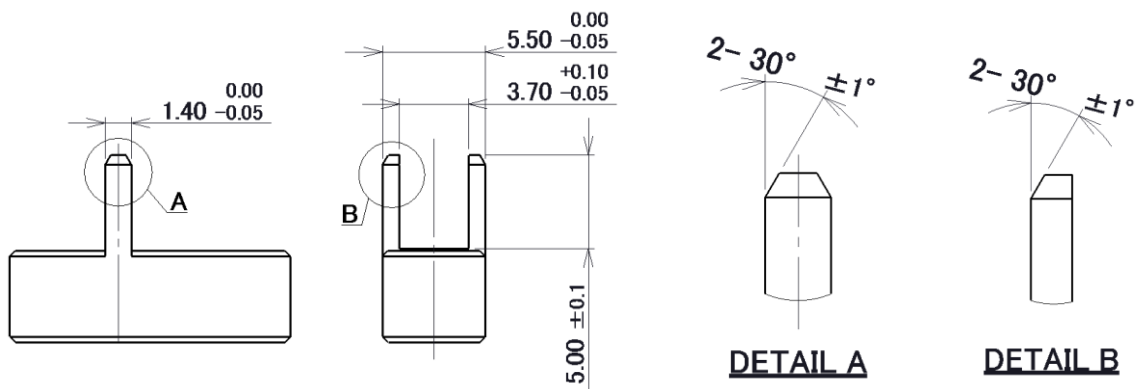

Fig.36 Dimensions of female retainer releasing jig

Notes

- ① Do not use the releasing jig for any other part of the female housing other than the releasing apertures.
Doing so may cause damage or reduced performance.
- ② Check for any deformation or damage on both of the female retainer and the female housing after releasing the female retainer, before continuing any operation.
- ③ If there is any damage or deformation, do not use it.
Replace the item with a new one.
- ④ Only use the retainer releasing jig specified.
- ⑤ Care must be taken not to damage edge of the jig (e.g. from dropping, etc.)

6-2. Male connector

- ① Insert a screwdriver(width :2.5mm MAX./thickness : 0.6mmMAX.) into the releasing jig aperture in the side surface of the male housing, and push out the male retainer. (see Fig.37).

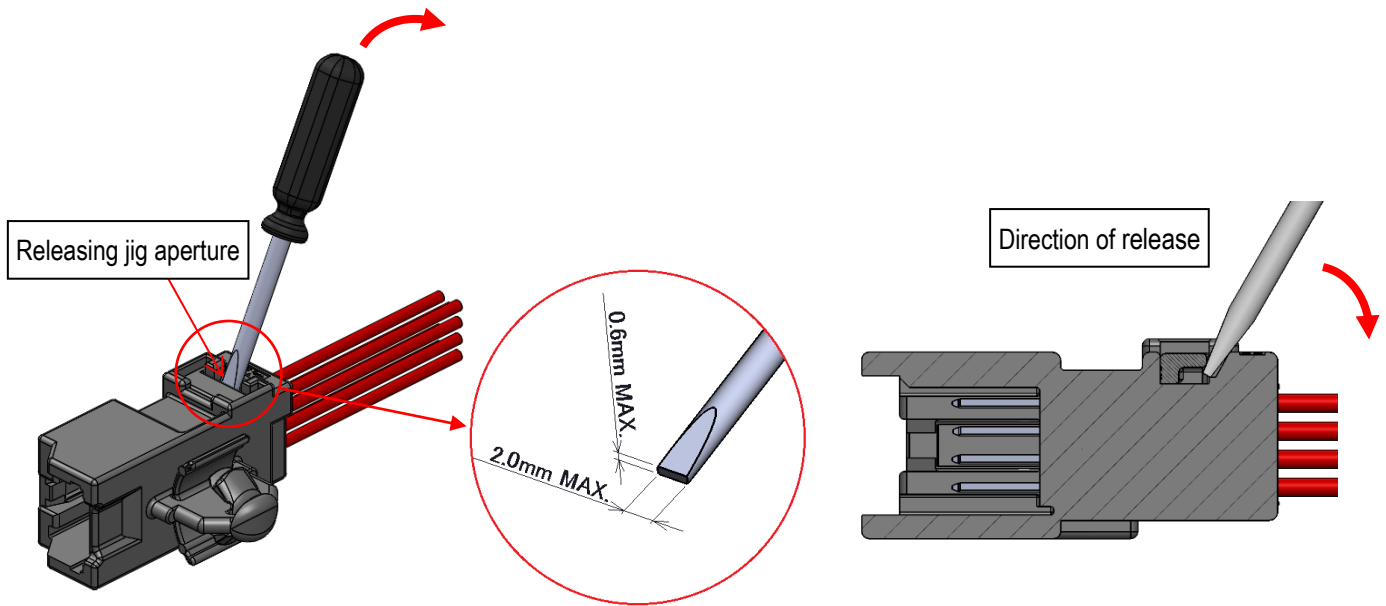

Fig.37 How to release the male retainer

Notes

- ① Do not use the screwdriver for any other part of the male housing other than the releasing apertures.
Doing so may cause damage or reduced performance.
- ② Complete releasing at the position where the releasing apertures comes out from the side surface of the male housing (Male retainer preset position). Therefore must not pull the retainer out any more.
It may cause damage or deformation of the female housing.
- ③ Check for any deformation or damage on both of the male retainer and the male housing after releasing the male retainer, before continuing any operation.
- ④ If there is any damage or deformation, do not use it.
Replace the item with a new one.
- ⑤ Only use the specified screwdriver for releasing the male retainer.
- ⑥ Do not use screwdriver with damage or deformation.

7. How to release terminals

- ① Ensure that the retainer has been removed.
- ② Hold the wire and push the terminal lightly. Insert the terminal releasing jig into the apertures of the housing (see Fig. 38 and 39).
- ③ Push fully the terminal releasing jig into the molding lance, then lever up the molding lance as shown in Fig. 38.

Keep the terminal releasing jig in that position and pull the terminal out by holding the wire. (see Figs. 38 and 39).

- ④ If there is any difficulty in pulling out the terminal, do not pull it forcefully. Check that the terminal releasing jig is in the correct position or it is pushed fully into the housing, and then repeat the procedures ① to ③.

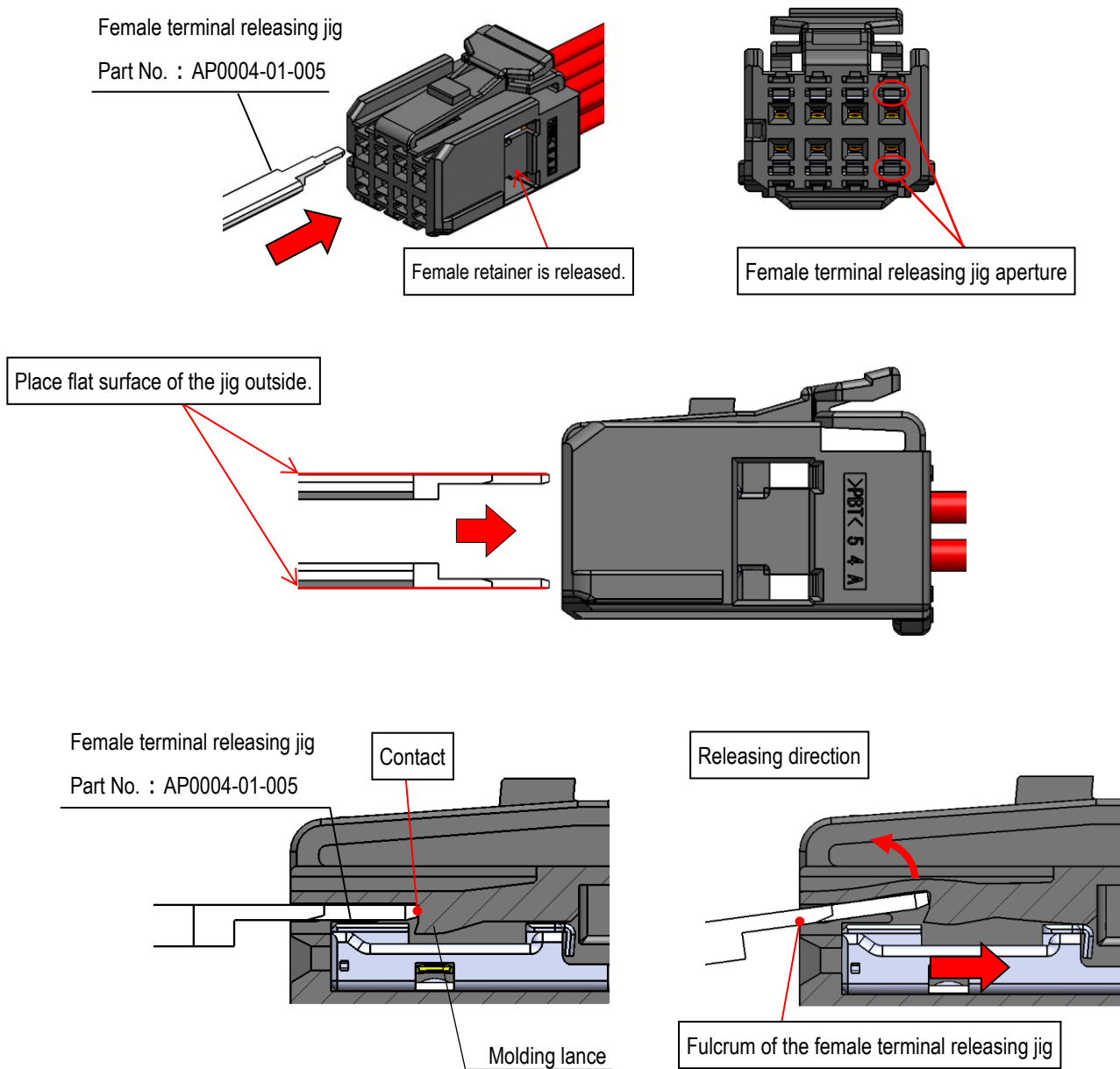

Fig.38 How to release the female terminal

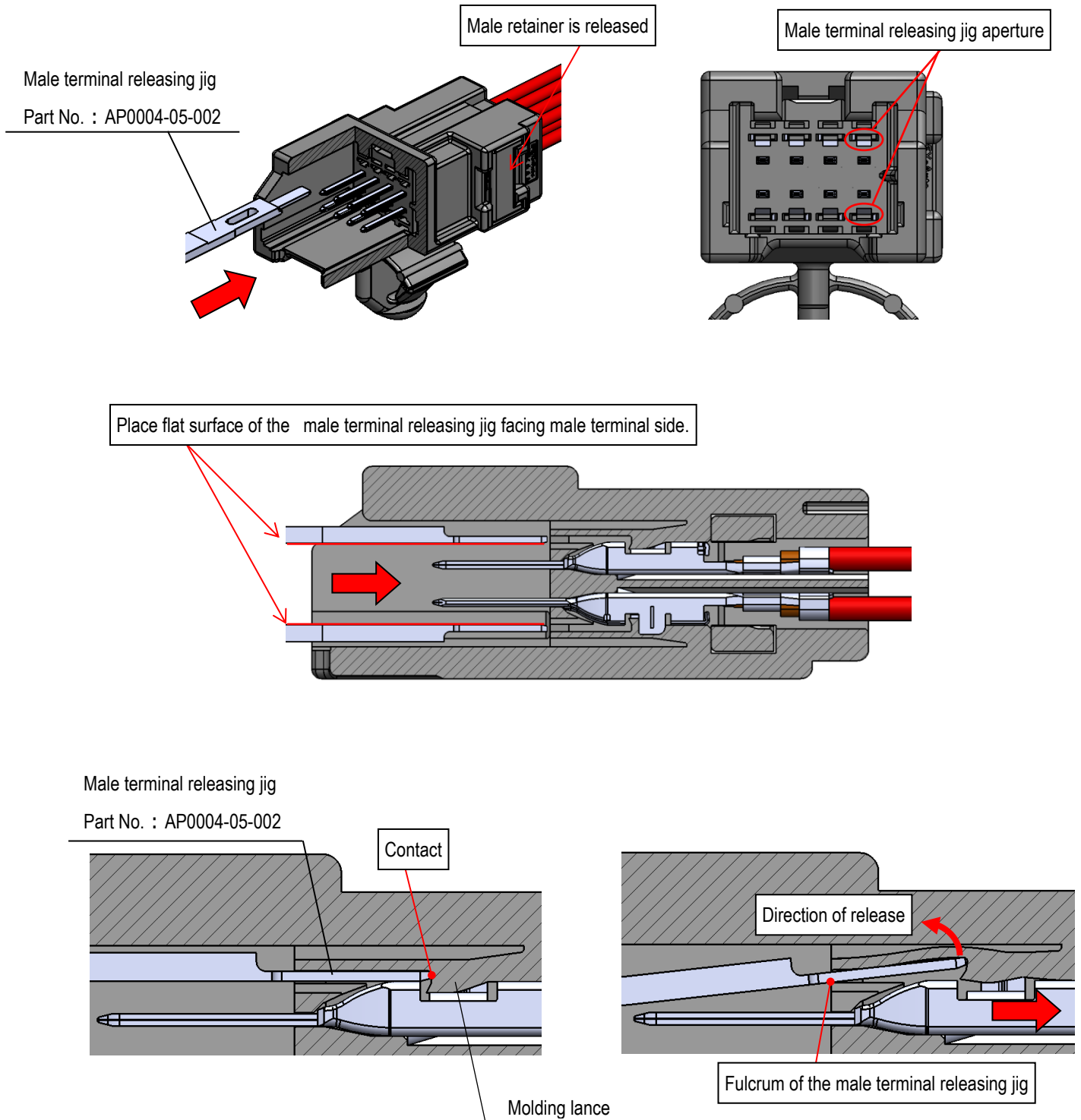

Fig.39 How to release the male terminal

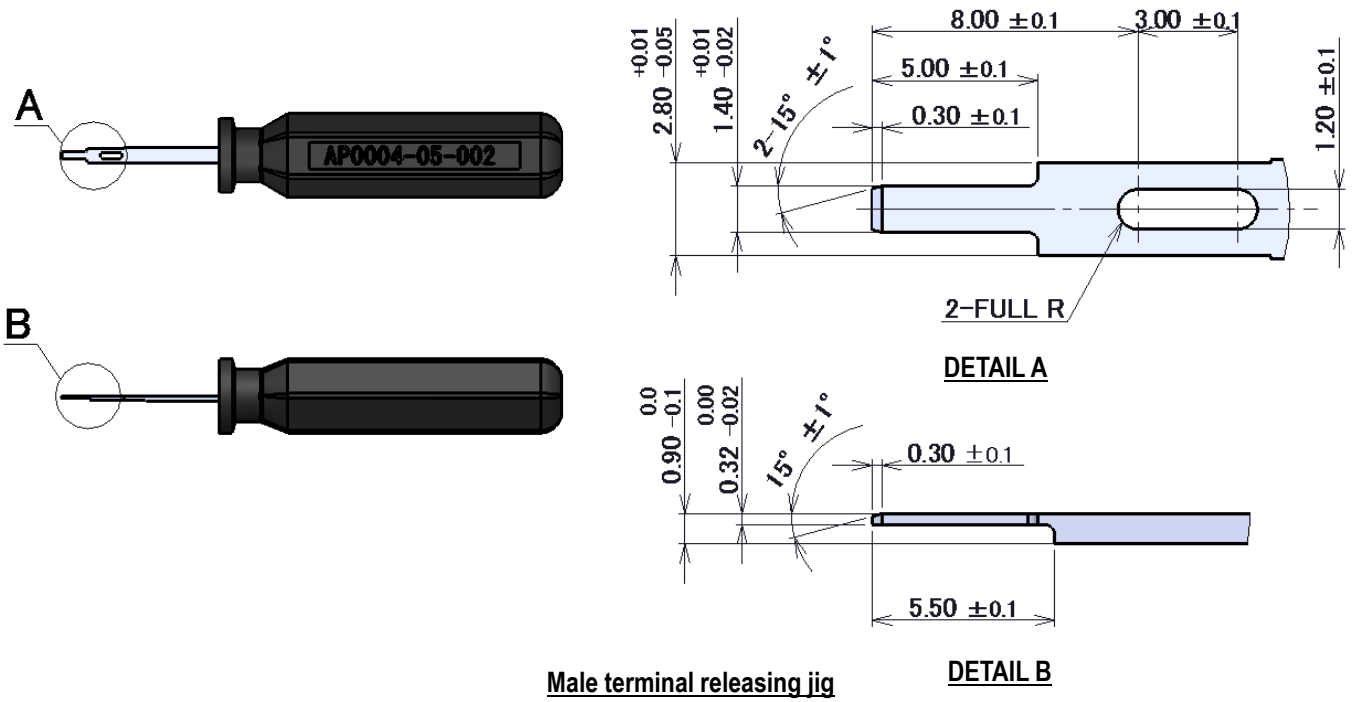
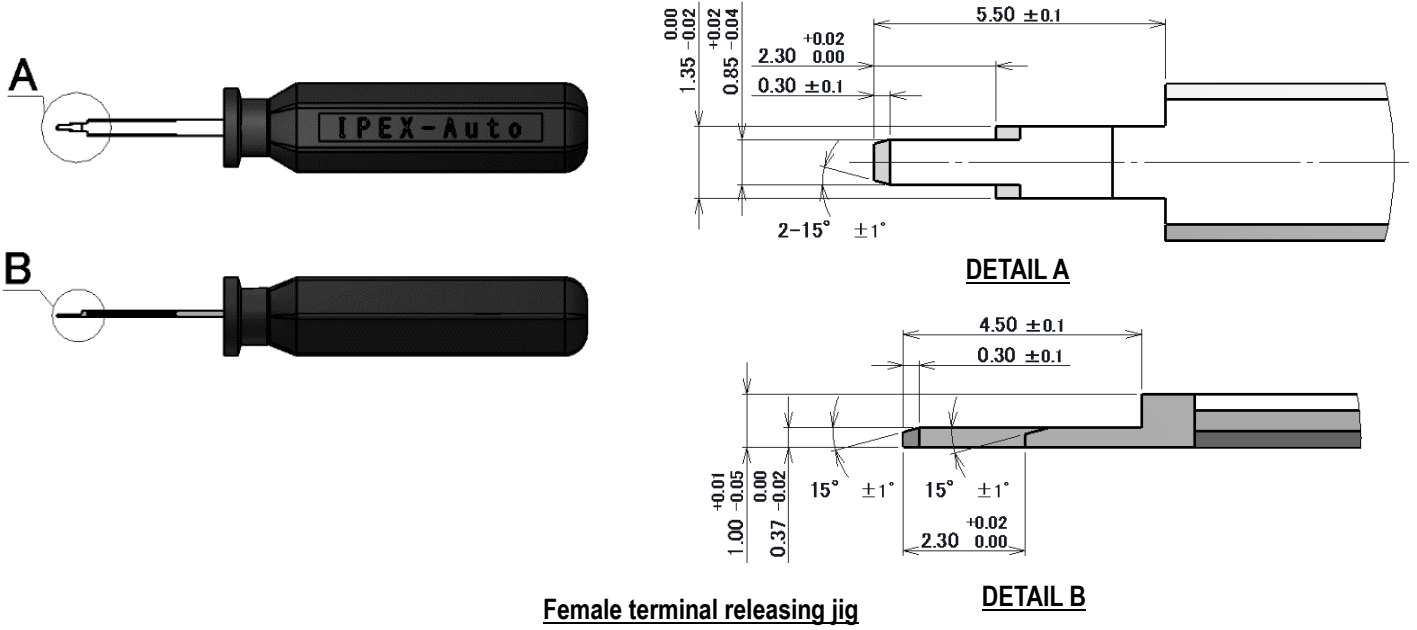

Fig.40 Dimensions of terminal releasing jig

Notes

- ① Do not pry with the terminal releasing jig or terminals during operation. Check for any deformation or damage on the terminals and the housing after releasing the terminals. (see Fig.41)
- ② Do not continue applying force once the molding lance has reached the ceiling, or the molding lance will be deformed or terminal releasing jig may be damaged by excessive force. Take sufficient care when handling.(see Fig.42)
- ③ If there is any damage or deformation on the terminal or the housing, do not use the damaged item.
Replace the item with a new one.

Replace the item with a new one.

- ④ Only use the terminal releasing jig specified.
- ⑤ Do not insert the releasing jig into the cavities (see Fig.43)

If the terminal releasing jig is inserted into the cavities by mistake, the terminal may be damaged.

Replace the terminal with a new terminal.

- ⑥ Care must be taken not to damage edge of the jig (e.g. from dropping, etc.)



Fig.41 Damage caused by releasing jig

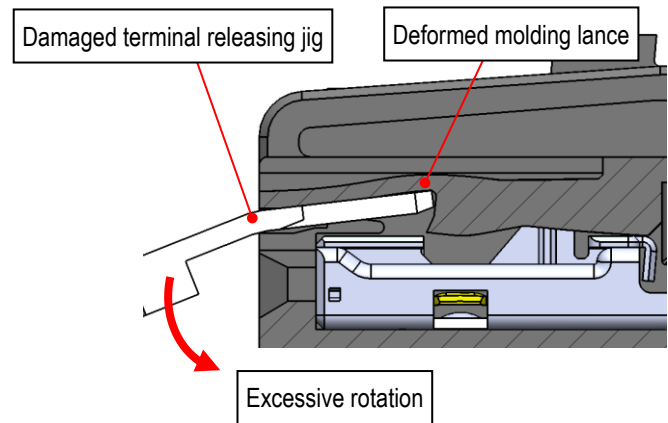

Fig.42 Deformed molding lance, Damaged releasing jig

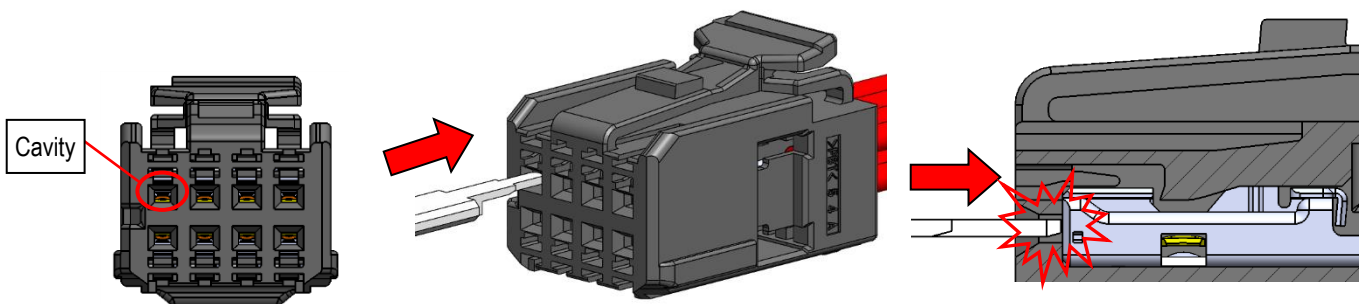

Fig. 43 Incorrect insertion of the terminal releasing jig

8. Mating of connector

- ① Push the female connector that has been installed the retainer in the direction of mating until makes an audible click (see Fig. 44). While mating the female connector, please do not touch the lock arm to prevent insufficient mating.
- ② After that, pull the female connector lightly to check that the female connector is locked.

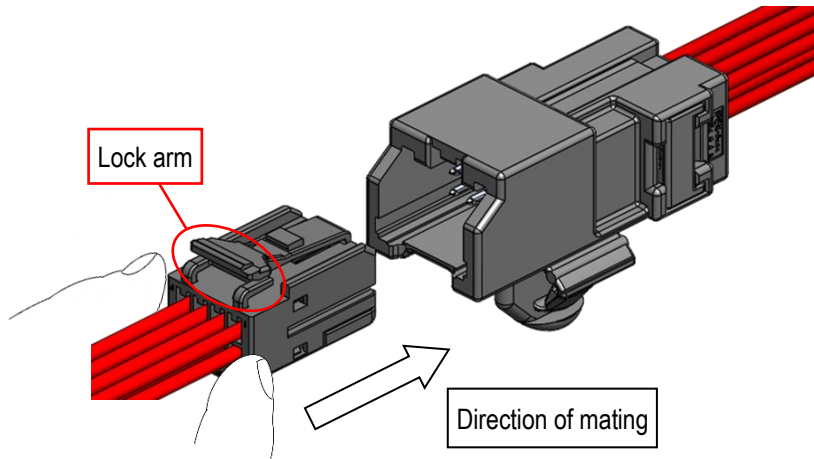

Fig. 44 Mating of connector

Notes

- ① Only mate the connector in the direction instructed above. Do not forcefully mate in any orientation shown in Fig.45. Doing so may cause damage or deformation to connectors.
- ② If there is any damage or deformation, do not use the damaged item. Replace the item with a new one.

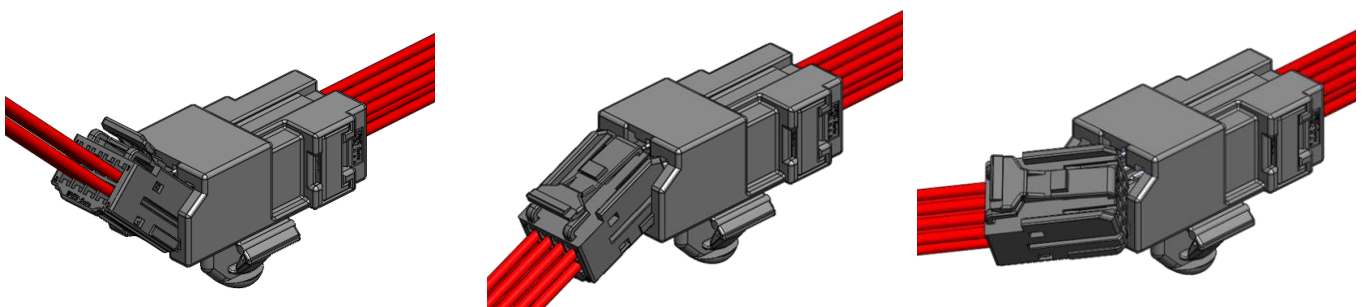

Fig. 45 Examples of incorrect mating orientation (not advisable)

9. Unmating of connector

- ① Hold the female connector and push it in lightly.
- ② While holding the female connector in, press down fully on the end of the lock arm (see Fig. 46).
- ③ Keep pressing the lock down, and pull out the female connector.

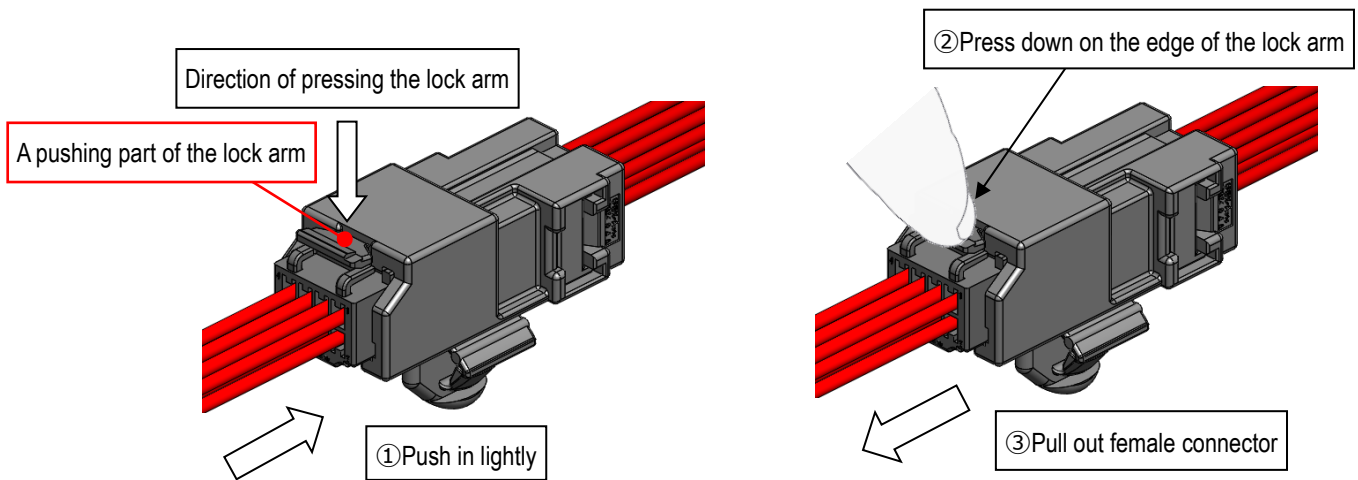

Fig. 46 Unmating of connector

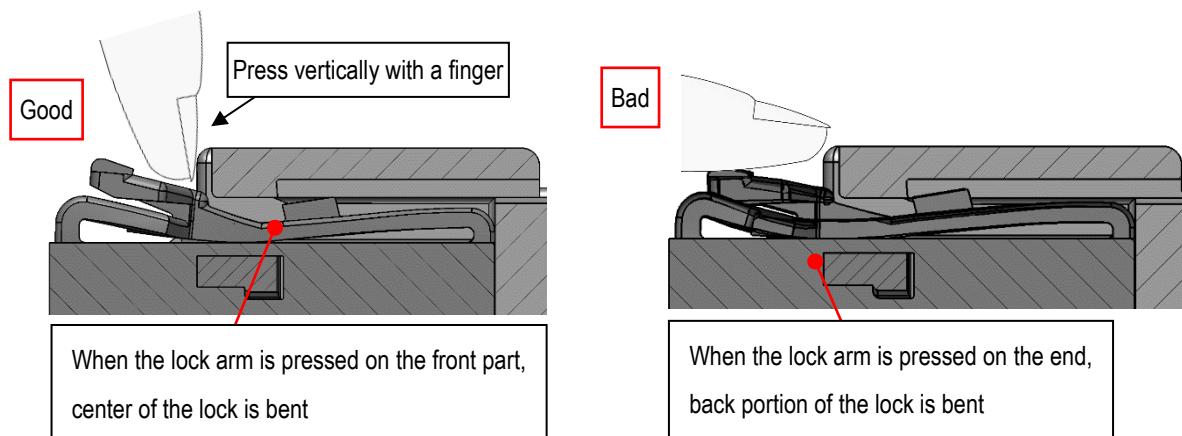

Fig. 47 ロック部構造/ Mechanism of the lock

Notes

- ① Do not pull out the female connector without the lock arm fully pressed down.
It may cause damage or deformation to the connector.
- ② Hold and pull the female connector (not the wires), when disengaging the female connectors.
- ③ If there is any damage or deformation, do not use the damaged item. Replace the item with a new one.
- ④ Pressing down the end of the lock arm may not release the lock fully (See Fig. 47).

10. Handling of Product

10-1. Conductivity test

10-1-1. Female connector

① Do not recommend to perform a conductivity test using the mated male connector.

If the same male connector is used for conductivity test, the connectors are repeatedly mated and unmated, and the male terminal could be bent. These may cause of the female terminal spring deformation, or the contact failure caused by adhesion the particles of friction according to excessive insertion and removal actions.

② To test electrical conductivity of female connector, place a probe pin at prescribed point (0.5N MAX.) on outside of the female terminal. (See Fig. 48)

③ Do not insert a probe pin into female terminal, as this may damage the terminal spring.

Do not use female terminal, if the probe pin has been inserted. Replace the female terminal.

④ Probe pin must be $\phi 0.55 \sim 0.70 \text{mm}$.

Must not be smaller than the gap between female housing and female terminal (0.5mm).

⑤ Once tested, check there is no deformation (e.g. collapse, etc.) of female housing.

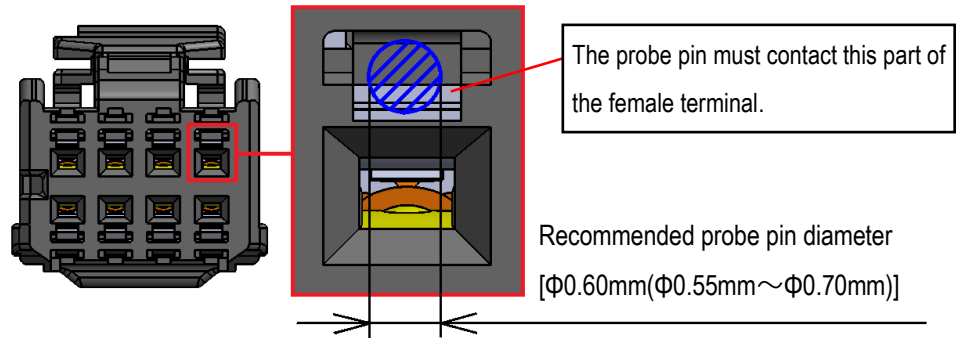

Fig.48 Conductivity test for female terminals (contacts)

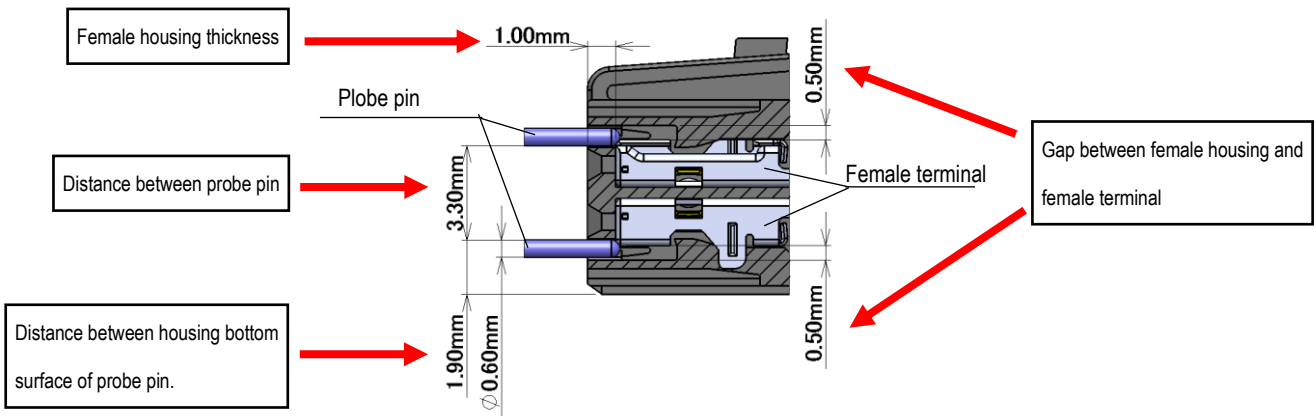

Fig.49 【Reference】Probe pin position on female connector

10-1-2. Male connector

- ① When carrying out conductivity test of the male connector, place the probe pin on the end of the male terminal (Load:0.5N MAX.).
(see Figs. 50)
If load 0.5N and more, male terminal(s) may be damaged.
- ② If there is any damage or deformation, do not use the damaged item. Replace the item with a new one.

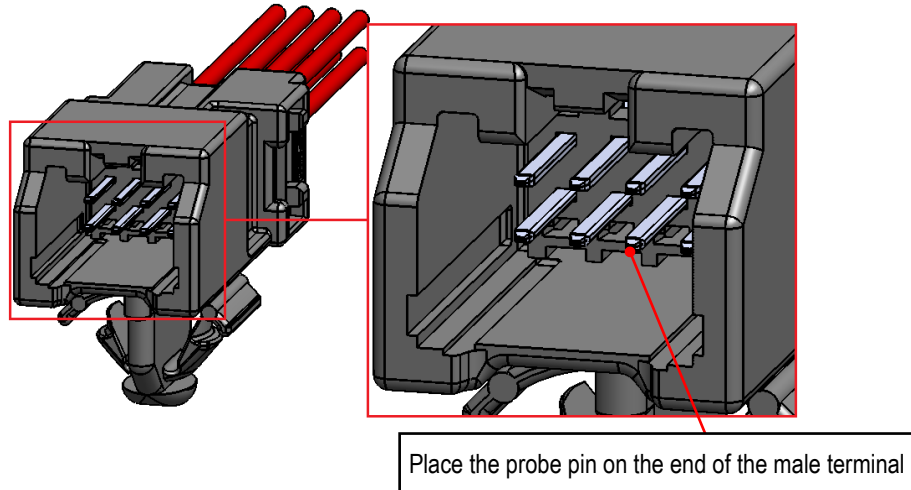

Fig.50 Conductivity test for male terminals (contacts)

10-2. Arrangement of Wires

- ① When arranging the wires to sideways, keep the wires in straight (at least 15mm) from the connector to avoid excessive stress to the housing sidewalls and terminals or the terminal leaning inside the housing as shown in Fig.51.
- ② Once straight portion is secured, arrange the wires with adequately large R.

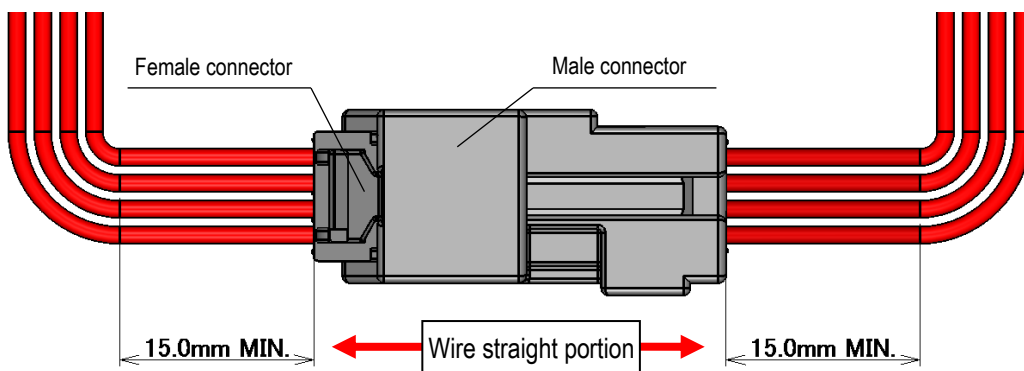

Fig.51 Arrangement of wires

11.Storage of housings and terminals

- ① Store housings and terminals in a warehouse which is controlled temperature and humidity.
(Recommend : Temperature 27°C MAX. , Humidity 65% MAX.)
- ② Store housings in a cardboard box. Avoid storing in a way that may cause damage to the boxes, e.g. placing boxes on top of other boxes or storing in a precarious way to cause the boxes to fall.
Housing may be deformed if the boxes have been damaged.
- ③ Store terminals in a cardboard box. Avoid storing in a way that may cause damage to the boxes, e.g. placing boxes on top of other boxes or storing in a precarious way to cause the boxes to fall.
Reel(s) or terminal(s) may be deformed if the boxes have been damaged.

12.Jigs

- ① Use the jig specialized for releasing the retainer and for releasing terminals.
- ② Table 2 shows the name of the releasing jig and their part number.
- ③ To purchase any of the jigs, please contact the Sales Dept. of our company at the following in 14(Sheet 29).

Table 2. Releasing Jig & Part No.

Jig name	Procedures	Jig part number	Product using the jig		Procedures detailed on
			Type	Part number	
Female terminal releasing jig	Releasing female terminal	AP0004-01-005	Female housing	V0020-91008-212	sheet 20
			Female retainer	V0027-92008-211	
			Female retainer	Vt001-512	
Male terminal releasing jig	Releasing male terminal	AP0004-05-002	Male connector	V0031-008B-201	sheet 21
			Male terminal	VT002-012	
Female retainer releasing jig	Releasing female retainer	AP0031-02-001	Female housing	V0020-91008-212	sheet 18
			Female retainer	V0027-92008-211	

13. Other notes

- ① Handle products with care. Do not place excessive force/impact to connectors main bodies or wires.
- ② Store products in a dry place without any dust or dirt.
Avoid storage for an extended period or any way that may cause damage or deformation to connectors.
- ③ While transporting of products should ensure that no excessive force must be applied to the connectors and wires, and that no rain water, dust and dirt, etc. are present.
- ④ Handle products with care. If there is any damage, deformation, discoloration, etc. to wires, housings, and any other parts, do not use the damaged item. Replace the item with a new one.
- ⑤ Do not touch the contact part of the connector with fingers or with any object.
- ⑥ Do not apply excessive current. Doing so may cause fire and melting damage.
- ⑦ Do not disassemble products.
- ⑧ Do not insert any terminals into housing other than those specified.
- ⑨ Follow this Manual for using the products. Do not use in any way other than instructed.

14. Contact

Tokyo office Sales Dept.

I-PEX Inc.

TEL: 03-5479-7410 FAX: 03-5479-7411