

Recommended P/N 20697-0**E-01#

PART No.	SIGNAL POS.	POWER POS.	A	B	C	D	E
20697-028E-01	28P	4P	9.79	7.99	5.60	4.55	9.19
20697-034E-01	34P	4P	10.84	9.04	6.65	5.60	10.24
20697-042E-01#	42P	4P	12.24	10.44	8.05	7.00	11.64
20697-056E-01#	56P	4P	14.69	12.89	10.50	9.45	14.09
20697-062E-01#	62P	4P	15.74	13.94	11.55	10.50	15.14

20697-0**E-01M

WITHOUT : 10,000 pcs/REEL
WITH : 5,000 pcs/REEL
Pos.

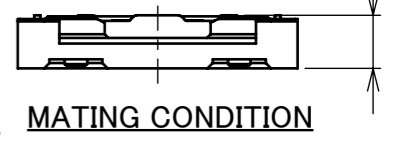
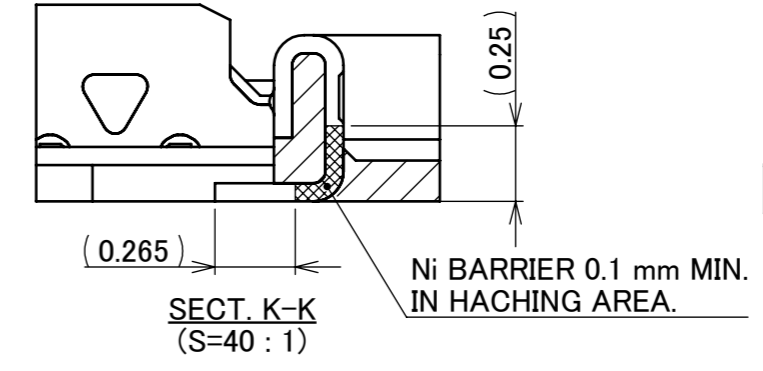
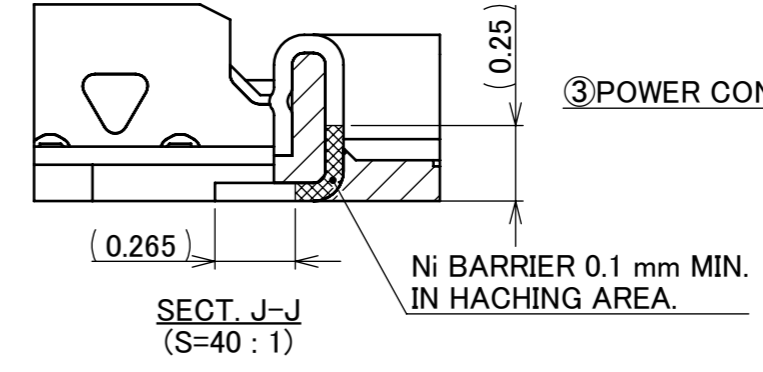
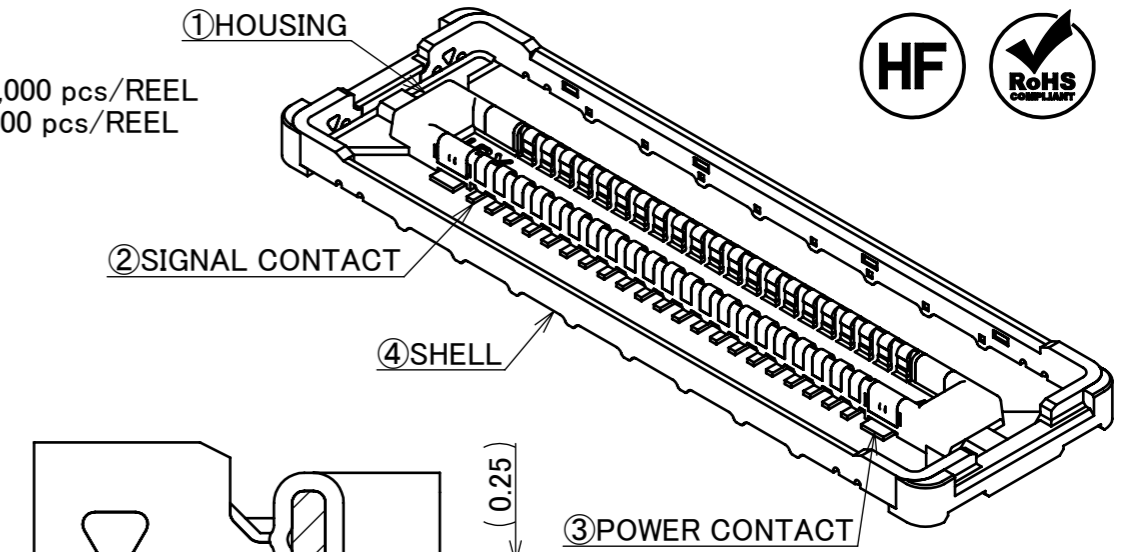
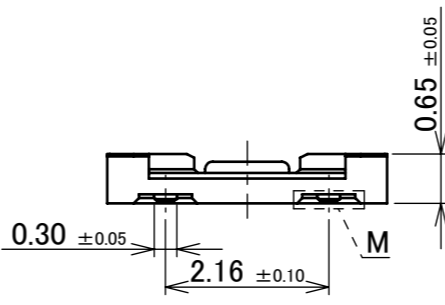
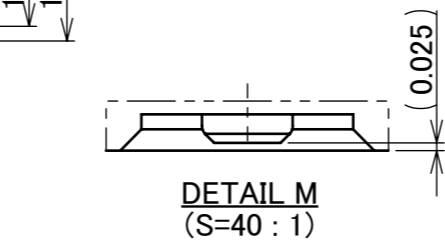
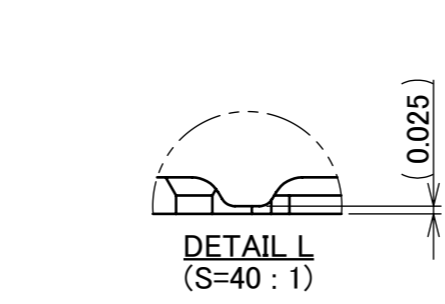
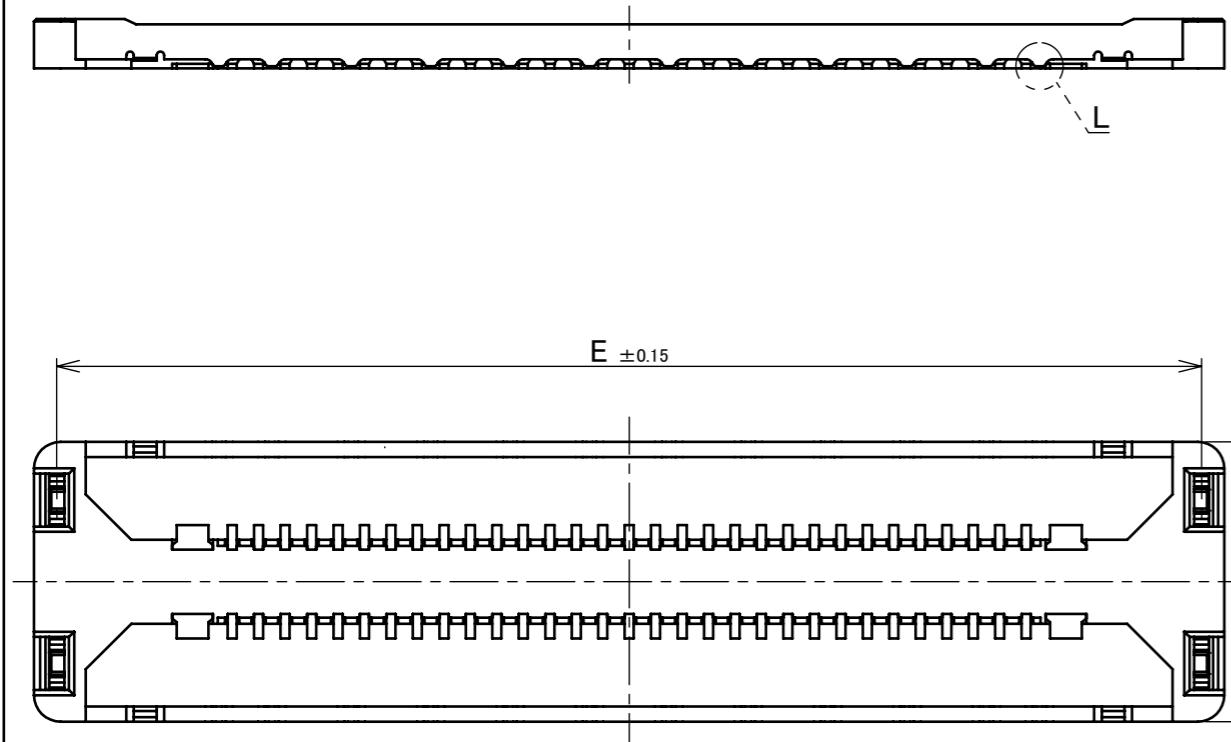
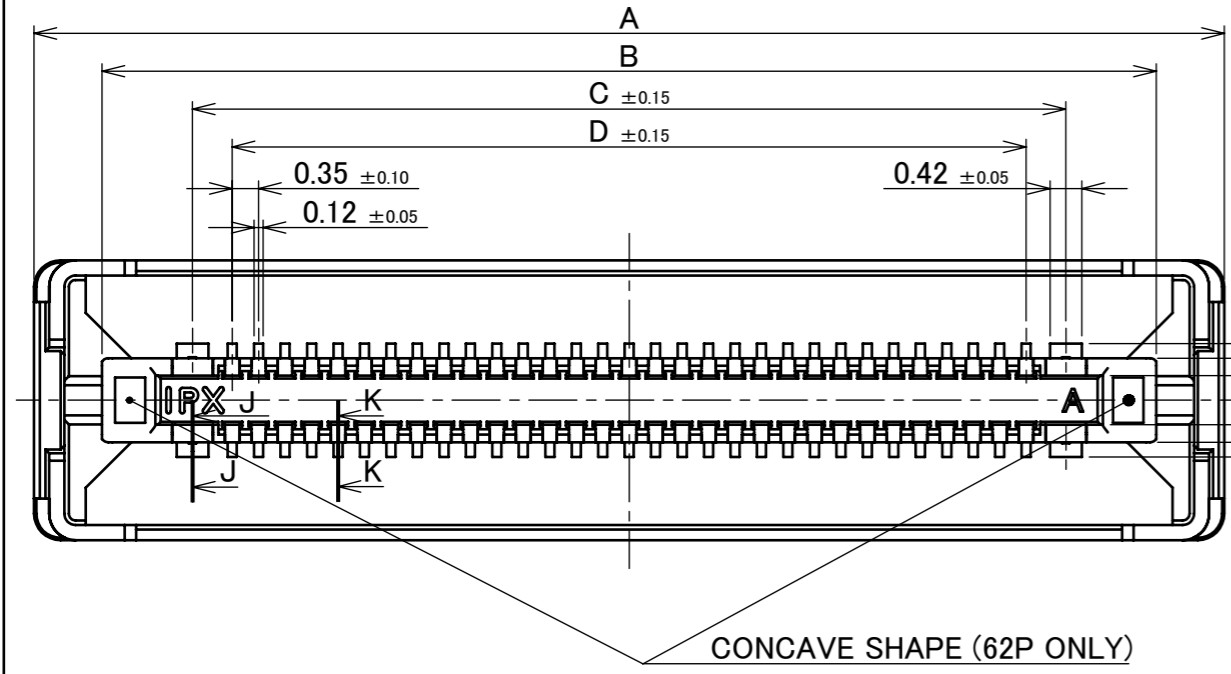

NO.	DISCRIPTION	MATERIAL	FINISH , REMARKS
4	SHELL	PHOSPHOR BRONZE	ALL OVER Ni 1.27 μm MIN. Au 0.01 μm MIN.
3	POWER CONTACT	CORSON ALLOY	ALL OVER Ni 1.27 μm MIN. CONTACT PART Au 0.05 μm MIN. SOLDERING PART Au 0.02 μm MIN.
2	SIGNAL CONTACT	CORSON ALLOY	ALL OVER Ni 1.27 μm MIN. CONTACT PART Au 0.05 μm MIN. SOLDERING PART Au 0.02 μm MIN.
1	HOUSING	LCP	UL94V-0, BLACK

REV.	ECN	BY	DATE	APP.	APP.	DATE	DWG. No.	20697	SIZE	A3	SHEET	1/8	REV.	6
6	Z200541	Y.B	May/26/'20	T.Y	ANGLE	±2°	6 OVER 30 MAX.	±0.3	PROJECTION	SERIES No.	R1	CUSTOMER COPY		
5	Z181722	Y.B	Dec./26/'18	TAK	6 MAX.	±0.2	30 OVER 120 MAX.	±0.5	TITLE	NOVASTACK® 35-HDP PLUG ASS'Y		SCALE	10:1	
4	Z180895	R.H	July/09/'18	TAK	GENERAL TOLERANCE.			UNIT	mm		I-PEX			
3	Z180170	T.K	Feb./09/'18	Y.S	DWG.	T.Kurachi	DATE	2016/01/13	NOVASTACK® 35-HDP PLUG ASS'Y		SIZE	A3		
2	Z161153	T.K	Sept./15/'16	J.T	CHK.				NOVASTACK® 35-HDP PLUG ASS'Y		SHEET	1/8		
1	Z160666	T.K	June/17/'16	J.T	APP.	J.Tateishi	DATE	2016/01/13	NOVASTACK® 35-HDP PLUG ASS'Y		REV.	6		
REVISION RECORD					APP.		DATE	2016/01/13	NOVASTACK® 35-HDP PLUG ASS'Y					

Confidential C

I-PEX Inc.

QKE-DFE06-02 REV.11

PART No.	SIGNAL POS.	POWER POS.
20697-028E-01	28P	4P
20697-034E-01	34P	4P
20697-042E-01#	42P	4P
20697-056E-01#	56P	4P
20697-062E-01#	62P	4P

20697-0**E-01M

WITHOUT : 10,000 pcs/REEL
WITH : 5,000 pcs/REEL

Pos.

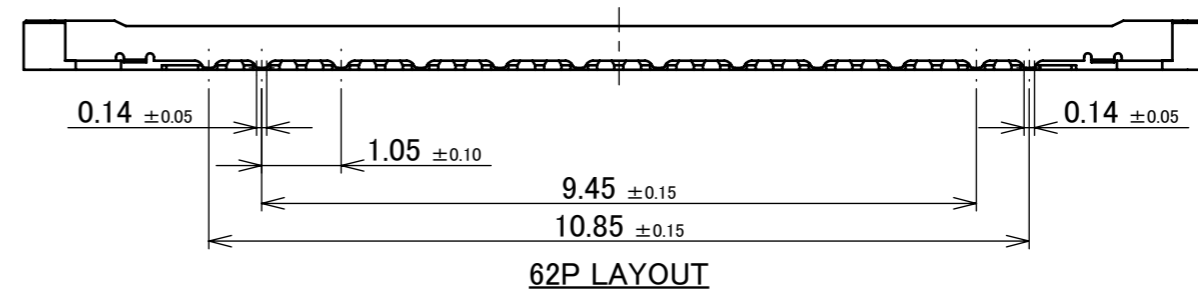
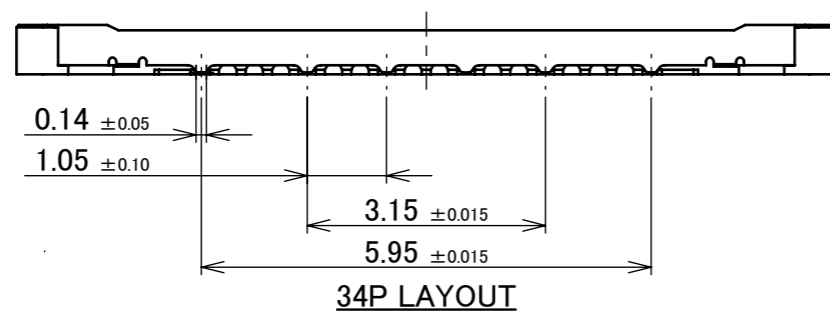
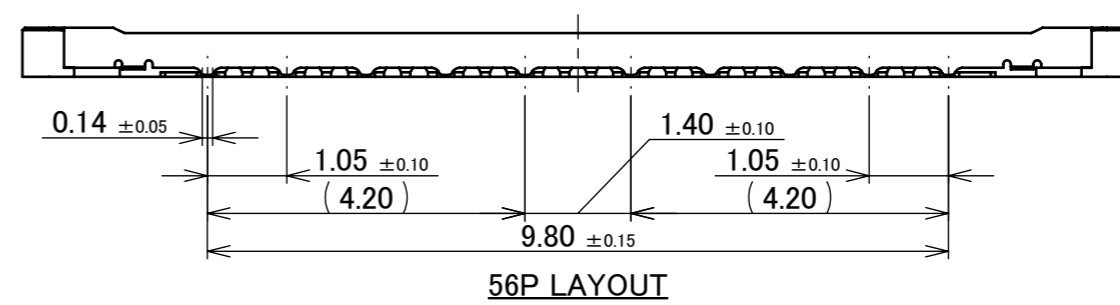
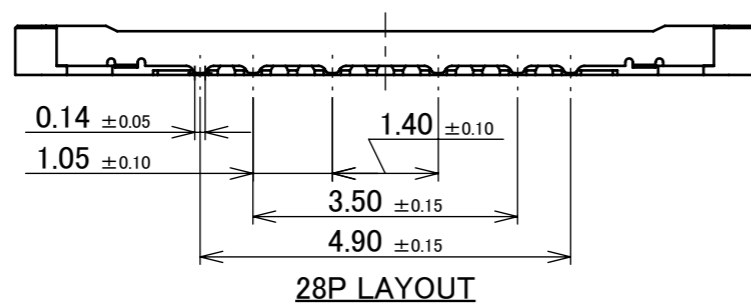
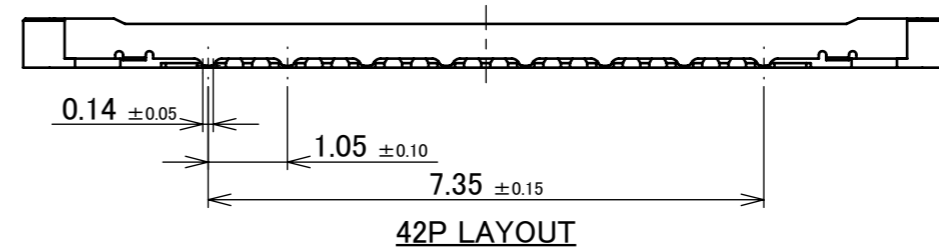

ANGLE	±2°	6 OVER 30 MAX.	±0.3	PROJECTION ⊕	SERIES No. R1	CUSTOMER COPY
	6 MAX.	±0.2	30 OVER 120 MAX.			
GENERAL TOLERANCE.				TITLE NOVASTACK® 35-HDP PLUG ASS'Y	SCALE 10:1	UNIT mm
DWG.	DATE					
CHK.						
APP.						
				DWG. No.	20697	SIZE A3
				SHEET	2/8	REV. 6

ITEMS	SPECIFICATION
RATING VOLTAGE	60V AC (PER A CONTACT)
RATING AMPERAGE (FOR SIGNAL CONTACT)	0.3A AC/DC (PER A CONTACT)/ 12.0A AC/DC(TOTAL)
RATING AMPERAGE (FOR POWER CONTACT)	2.2A AC/DC (PER A CONTACT)/ 8.8A AC/DC(TOTAL)
OPERATING TEMPERATURE	233~358K(-40°C~+85°C)
OPERATING HUMIDITY	85% MAX.(NON-CONDENSING)
CONTACT RESISTANCE (FOR SIGNAL CONTACT)	INITIAL : 40mohm MAX. / AFTER TEST : \triangle 40mohm MAX.
CONTACT RESISTANCE (FOR POWER CONTACT)	INITIAL : 20mohm MAX. / AFTER TEST : \triangle 20mohm MAX.
CONTACT RESISTANCE (FOR GROUND)	INITIAL : 20mohm MAX. / AFTER TEST : \triangle 20mohm MAX.
INSULATION RESISTANCE	INITIAL : 1,000Mohm MIN. / AFTER TEST : 500Mohm MIN.
DIELECTRIC WITHSTANDING VOLTAGE	AC250V 1min
DURABILITY	30 CYCLES
MATING FORCE (INITIAL)	1.0N \times n + 4.0N MAX.
UNMATING FORCE (AFTER TEST)	0.1N \times n + 0.4N MIN.
COPLANARITY	CONTACT AND POWER CONTACT: 0.08 MAX. SHELL: 0.105 MAX.
PRODUCT SPECIFICATION	PRS-2187
TEST REPORT	TR-16014
PACKING STANDARD	PST-15083 (10K/REEL) PST-16125 (5K/REEL)
INSTRUCTION MANUAL	HIM-15020
APPEARANCE CRITERIA No.	QLS-A***

ANGLE	$\pm 2^\circ$	6 OVER 30 MAX.	± 0.3	PROJECTION 	SERIES No. R1	CUSTOMER COPY
	6 MAX.	± 0.2	30 OVER 120 MAX.			
GENERAL TOLERANCE.				TITLE NOVASTACK® 35-HDP PLUG ASS'Y	SCALE	UNIT mm
DWG.	DATE					
CHK.						
APP.						
				DWG. No.	20697	SIZE A3
				SHEET	3/8	REV. 6

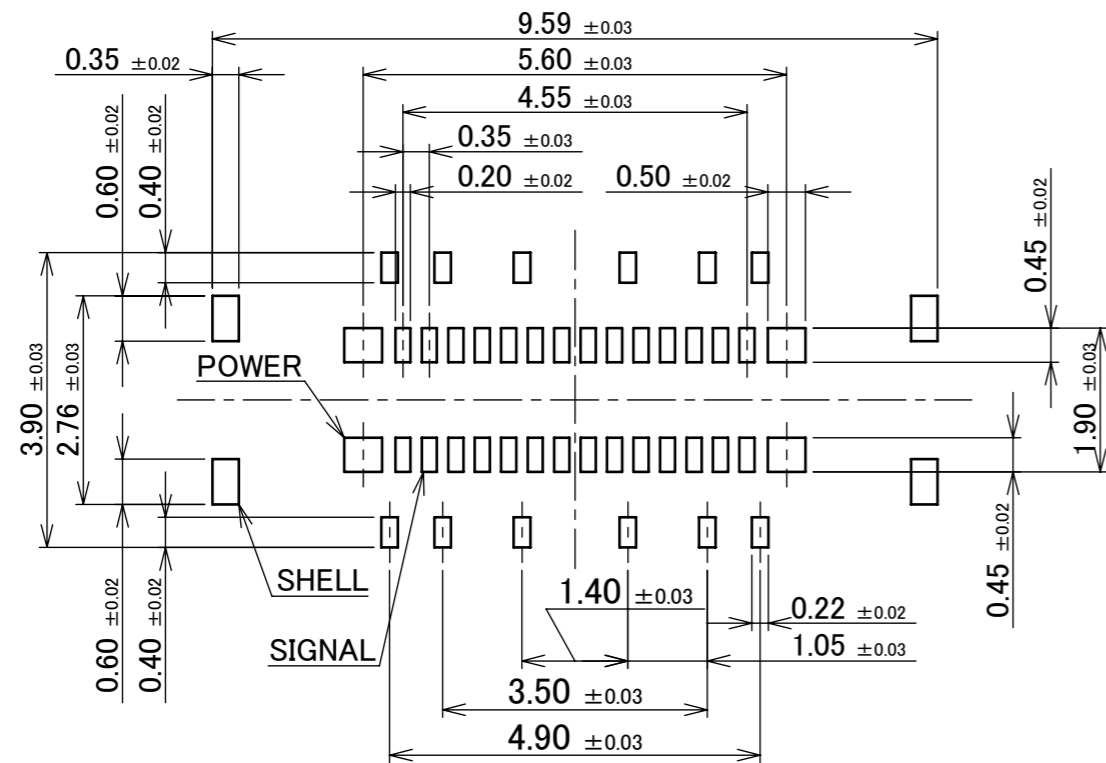

RECOMMENDED PATTERN LAYOUT (28P)

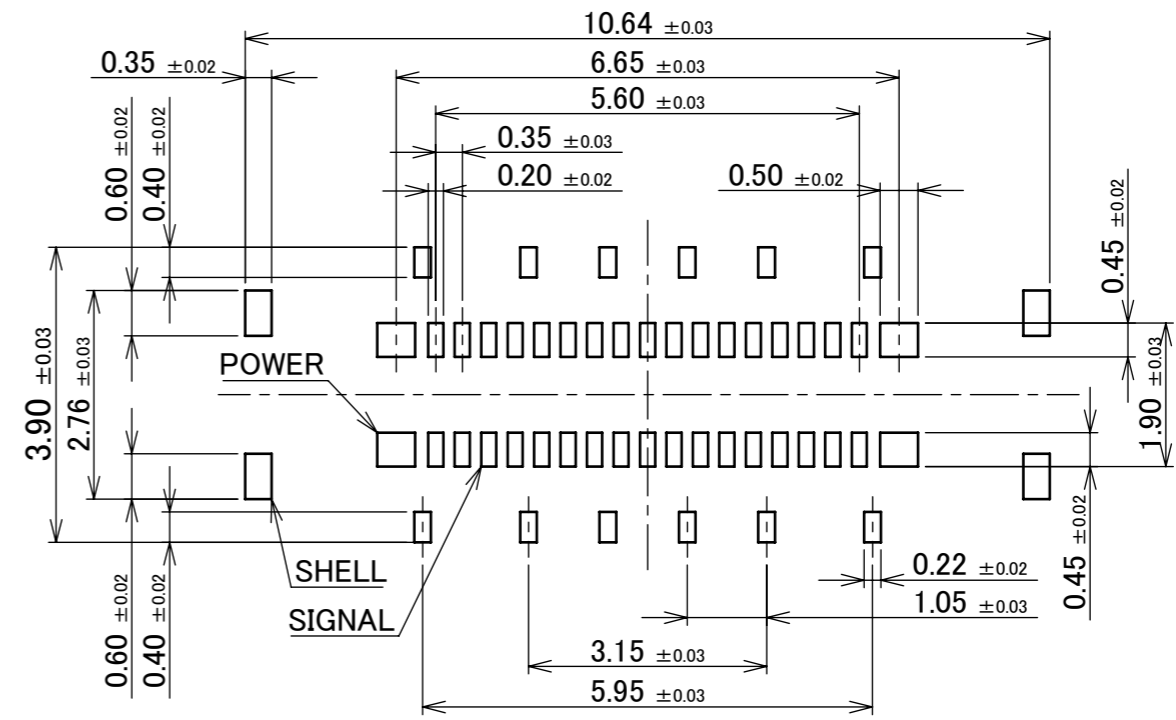

RECOMMENDED PATTERN LAYOUT (34P)

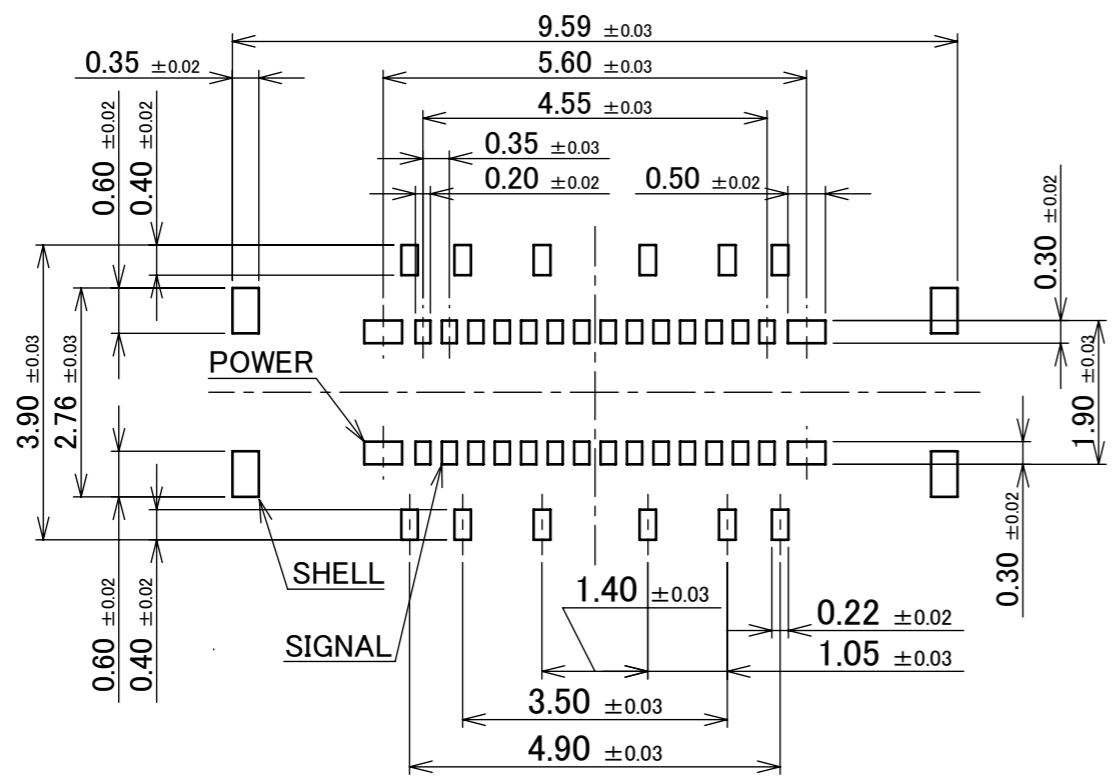

RECOMMENDED METAL MASK LAYOUT (28P)

THICKNESS : t=0.10 mm

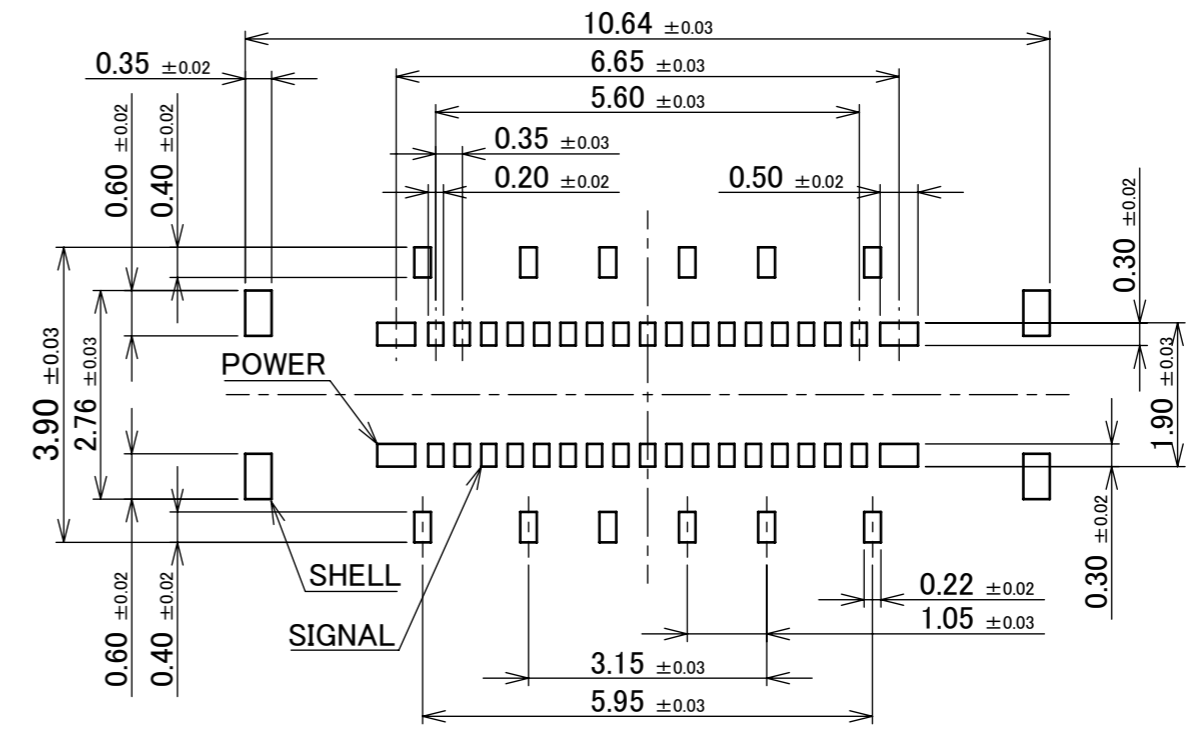

RECOMMENDED METAL MASK LAYOUT (34P)

THICKNESS : t=0.10 mm

ANGLE	±2°	6 OVER 30 MAX.	±0.3	PROJECTION ⊕	SERIES No. R1	CUSTOMER COPY
	6 MAX.	±0.2	30 OVER 120 MAX.			
GENERAL TOLERANCE.				TITLE		SCALE
DWG.	DATE			NOVASTACK® 35-HDP PLUG ASS'Y		10:1
CHK.						UNIT mm
APP.				DWG. No. 20697		SIZE A3
						SHEET 4/8
						REV. 6

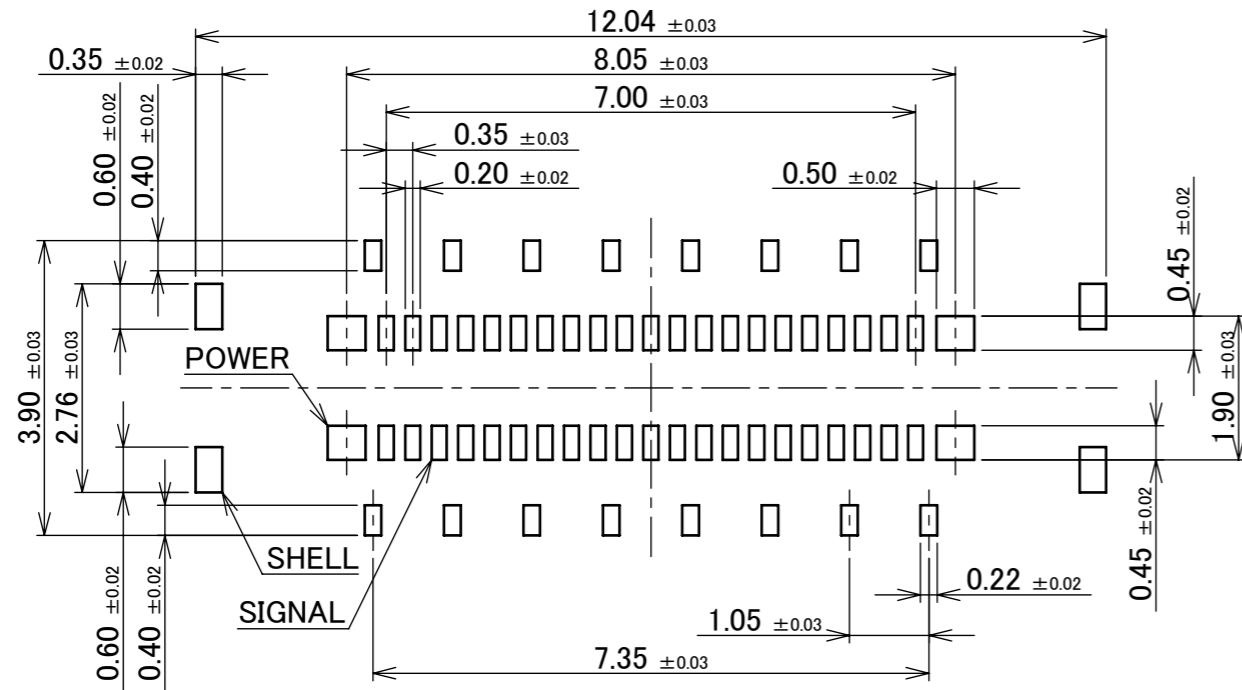

RECOMMENDED PATTERN LAYOUT (42P)

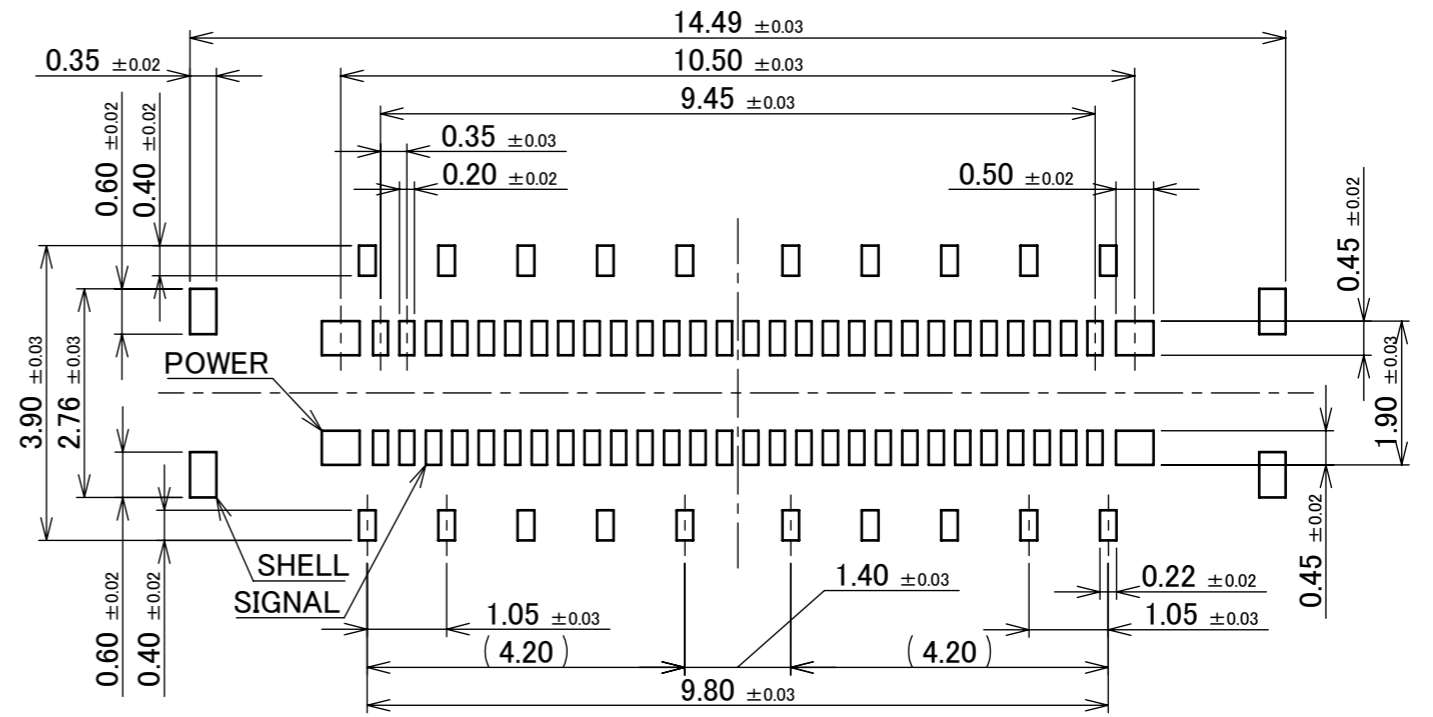

RECOMMENDED PATTERN LAYOUT (56P)

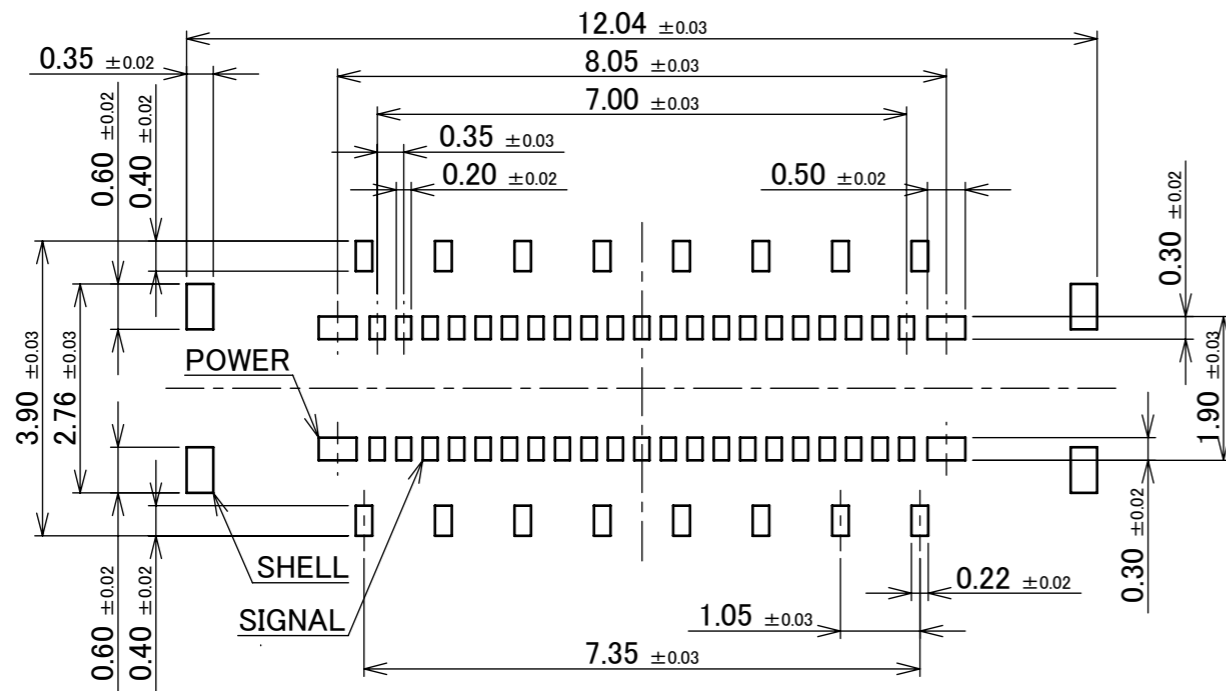

RECOMMENDED METAL MASK LAYOUT (42P)
THICKNESS : t=0.10 mm

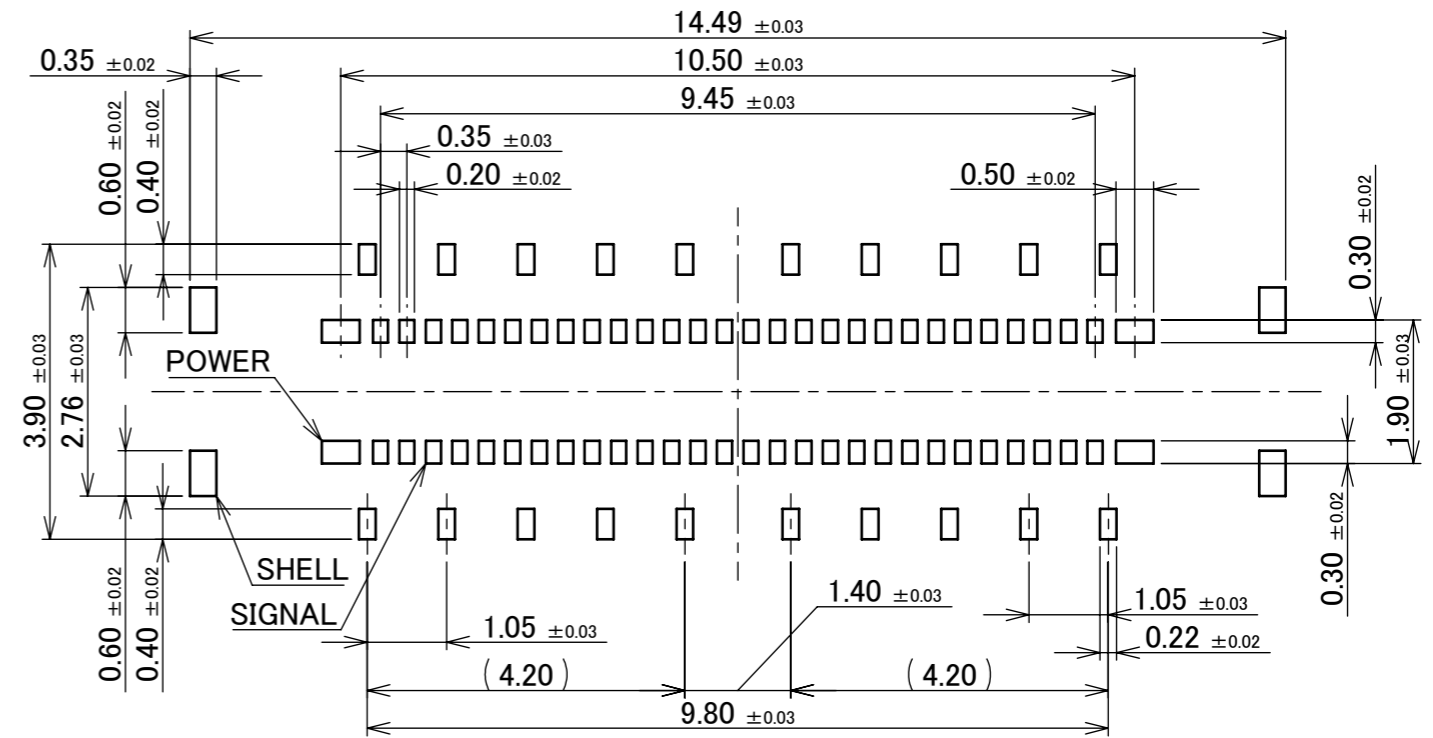

RECOMMENDED METAL MASK LAYOUT (56P)
THICKNESS : t=0.10 mm

ANGLE	±2°	6 OVER 30 MAX.	±0.3	PROJECTION ⊕	SERIES No. R1	CUSTOMER COPY	
	6 MAX.	±0.2	30 OVER 120 MAX.			±0.5	SCALE
GENERAL TOLERANCE.				TITLE		10:1	
DWG.	DATE			NOVASTACK® 35-HDP PLUG ASS'Y		UNIT mm	
CHK.				DWG. No. 20697		SIZE A3	
APP.						SHEET 5/8	REV. 6

PART No.	SIGNAL POS.	POWER POS.	A
20697-028E-01	28P	4P	9.79
20697-034E-01	34P	4P	10.84
20697-042E-01#	42P	4P	12.24
20697-056E-01#	56P	4P	14.69
20697-062E-01#	62P	4P	15.74

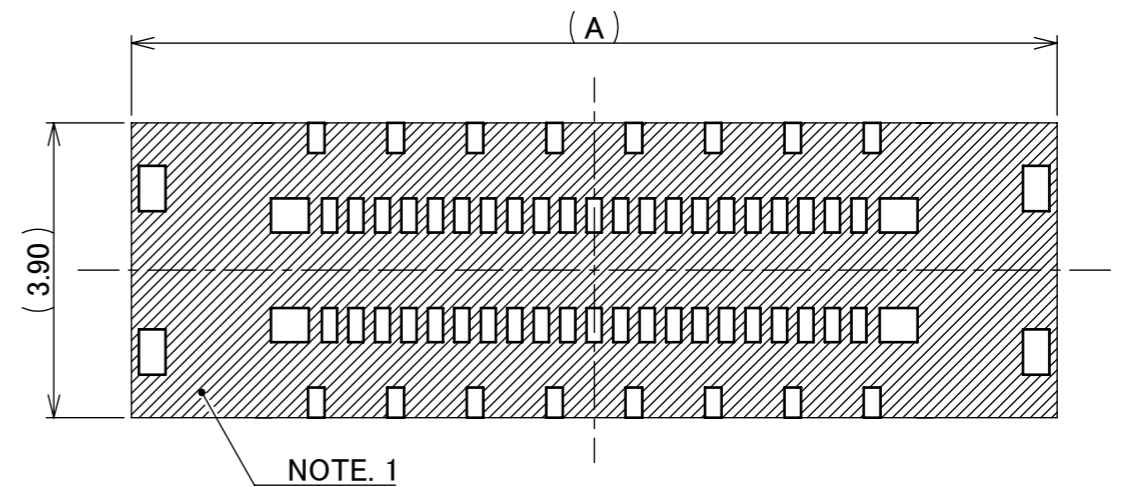
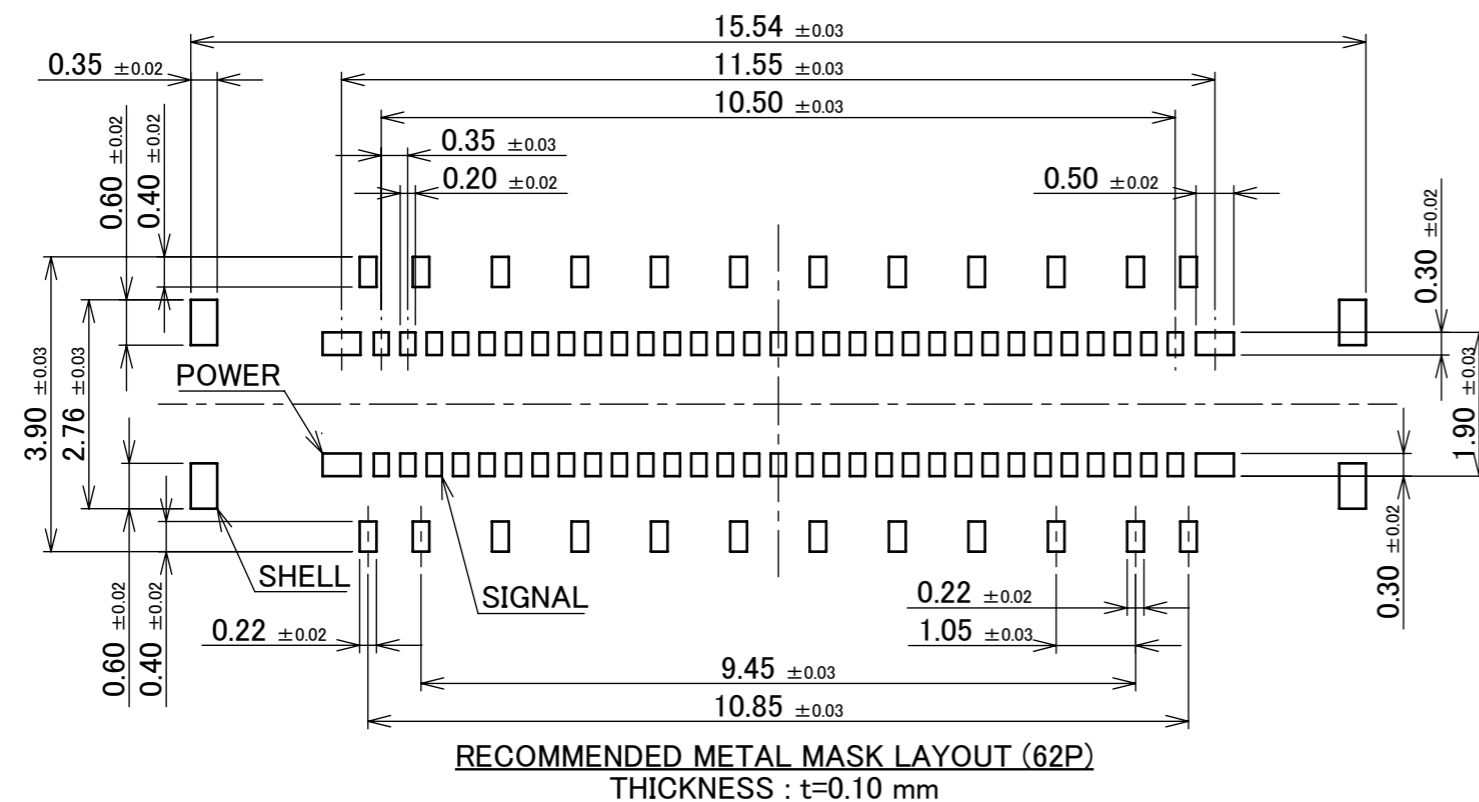
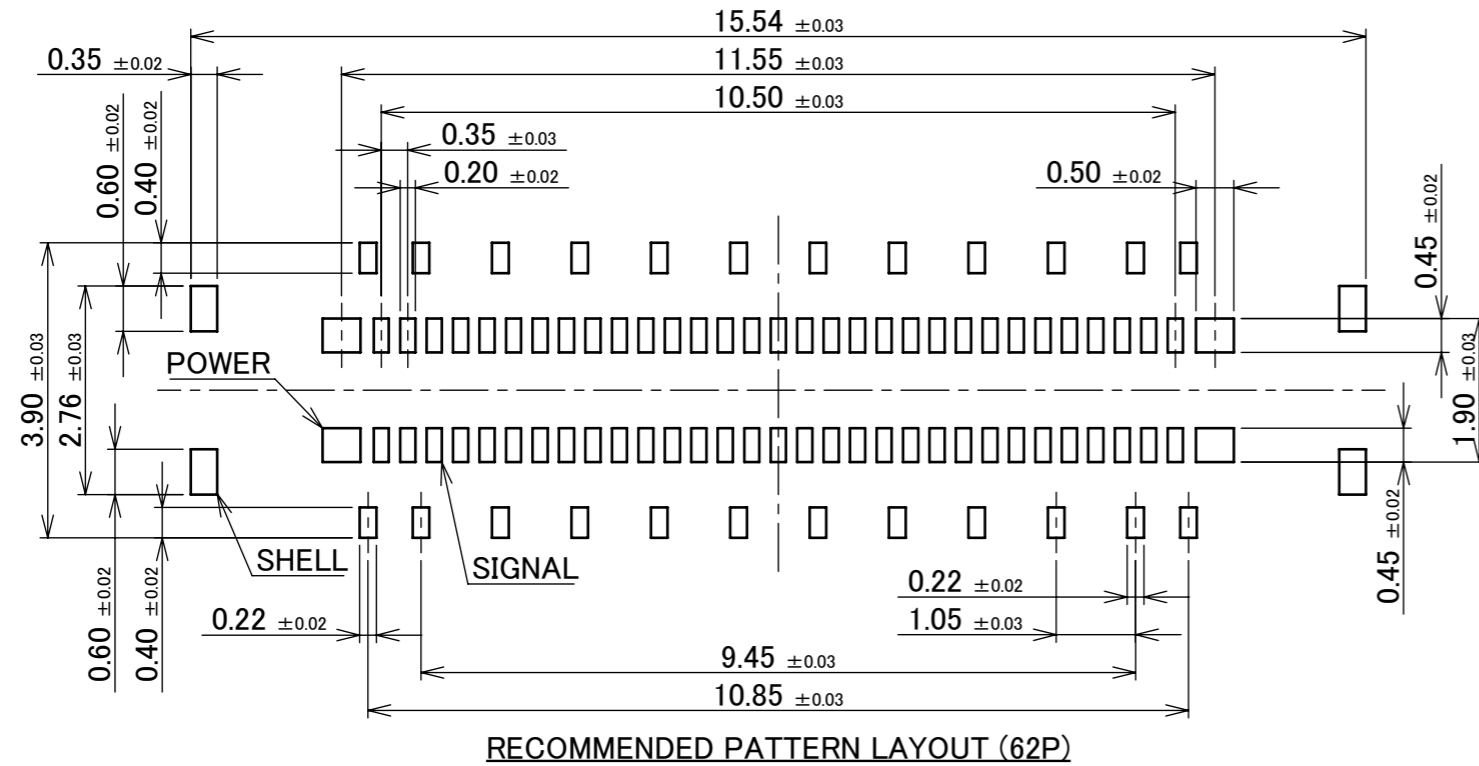

NOTES.
1. THIS AREA CANNOT MOUNT ANOTHER COMPONENTS.

ANGLE	±2°	6 OVER 30 MAX.	±0.3	PROJECTION ⊕	SERIES No. R1	CUSTOMER COPY
	6 MAX.	±0.2	30 OVER 120 MAX.			
GENERAL TOLERANCE.				TITLE NOVASTACK® 35-HDP PLUG ASS'Y	SCALE 10:1	UNIT mm
DWG.	DATE					
CHK.						
APP.						
				DWG. No.	20697	SIZE A3
				SHEET	6/8	REV. 6

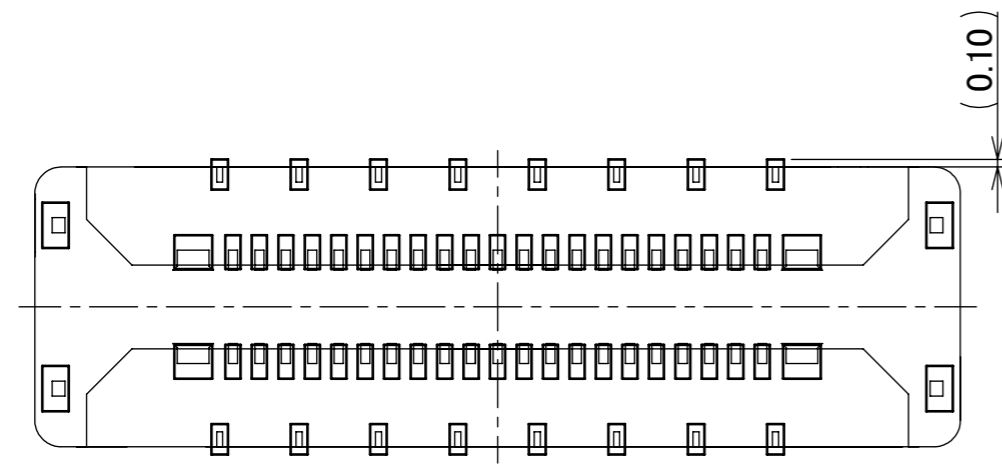

CONNECTOR ON RECOMMENDED FOOTPRINT PATTERN

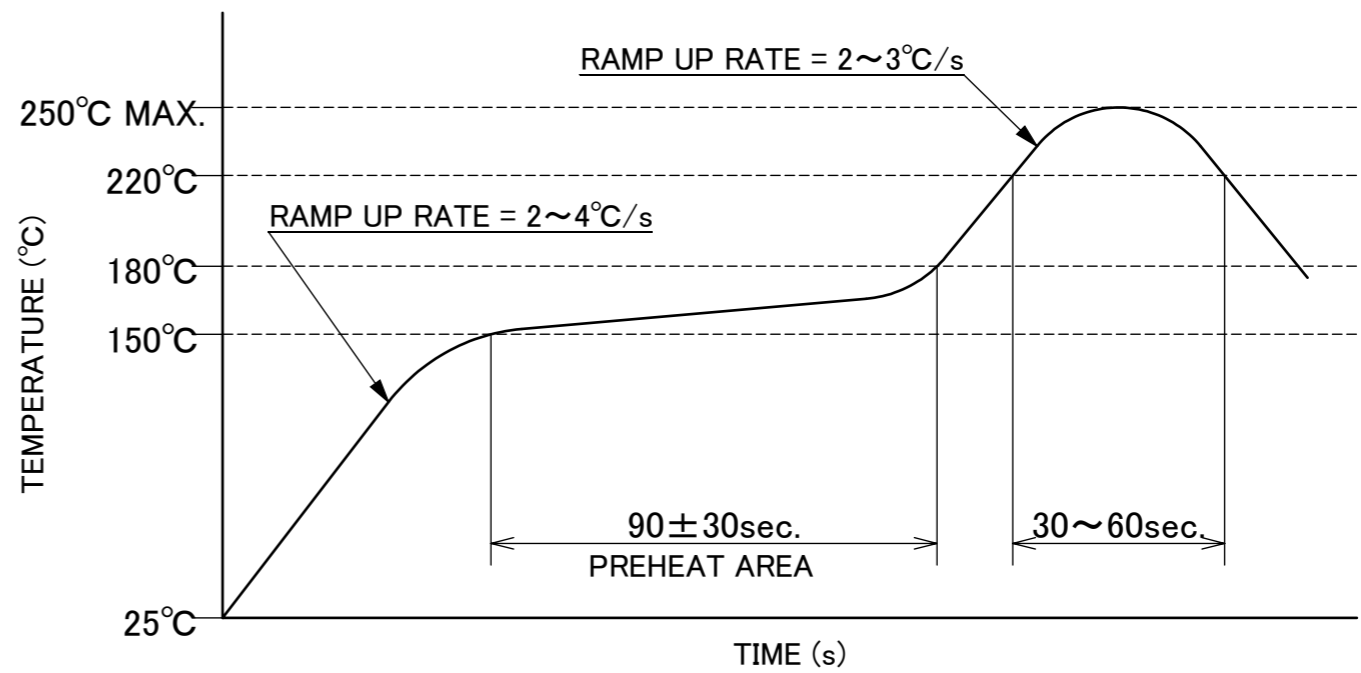

REFLOW TEMPERATURE PROFILE
 SENJU METAL INDUSTRY CO., LTD. : M705-SHF(Sn96.5 Ag3.0 Cu0.5)

ANGLE	±2°	6 OVER 30 MAX.	±0.3	PROJECTION 	SERIES No. R1	CUSTOMER COPY		
6 MAX.	±0.2	30 OVER 120 MAX.	±0.5					
GENERAL TOLERANCE.				TITLE NOVASTACK® 35-HDP PLUG ASS'Y	SCALE 10:1	UNIT I-PEX		
DWG.	DATE							
CHK.								
APP.								
				DWG. No.	20697	SIZE A3	SHEET 7/8	REV. 6

PART NO.	Pos.	QTY. PER EMBOSS REEL (PIECES / REEL)	QTY. PER PACKING CARTON
20697-0**E-01	28P	10,000 / REEL	10,000 × 5 REELS = 50,000
	34P		
	42P		
	56P		
	62P		
20697-0**E-01M	42P	5,000 / REEL	5,000 × 5 REELS = 25,000
	56P		
	62P		

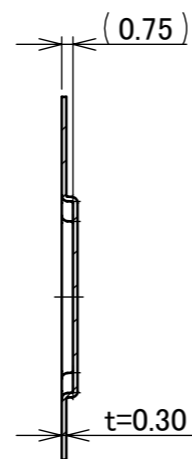
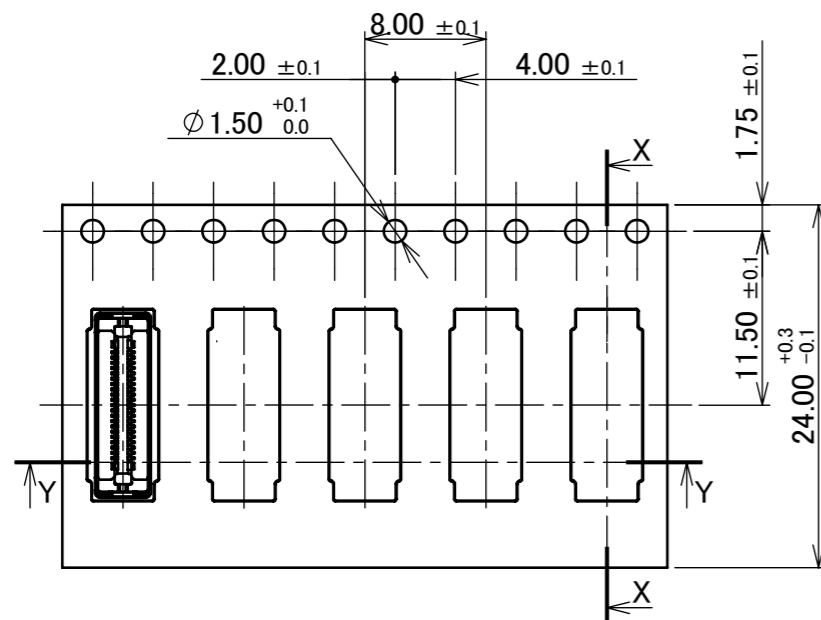
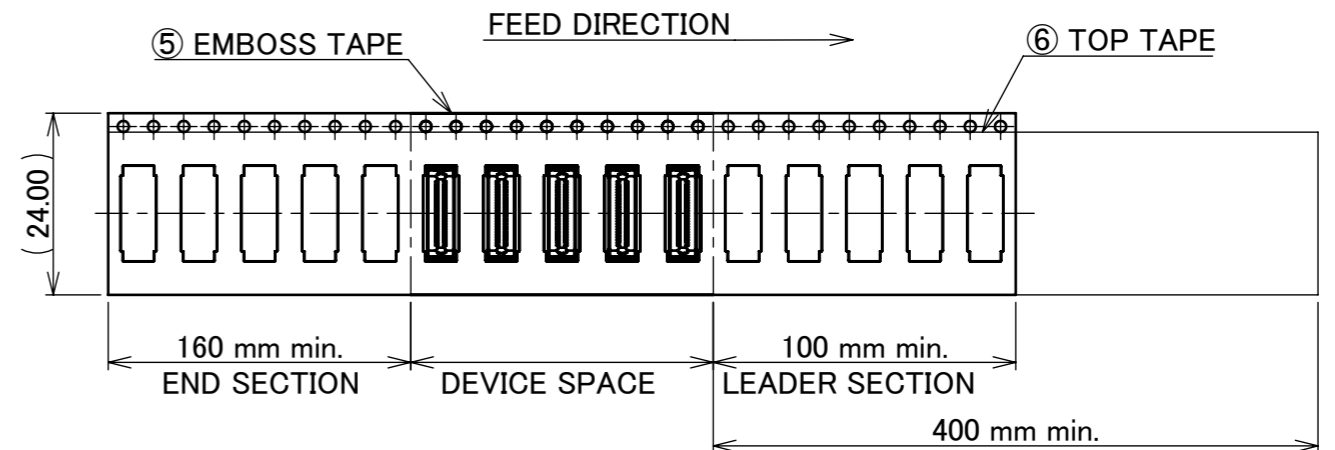
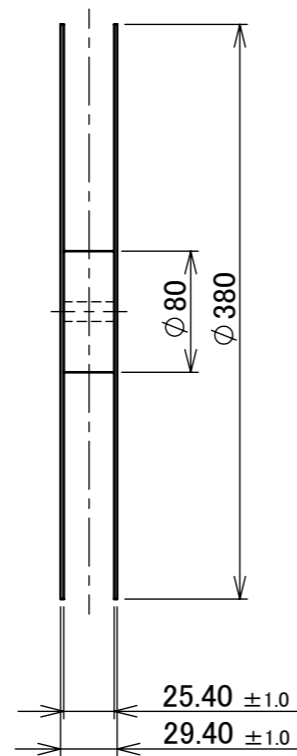
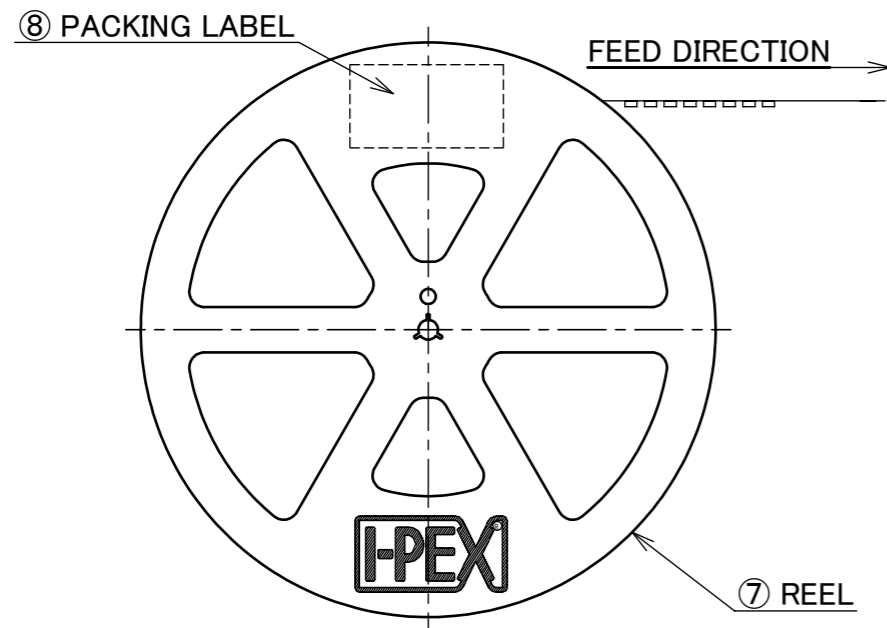

SECT. X-X
(S= 2 : 1)

SECT. Y-Y
(S= 2 : 1)

NOTES.

- TAPING SPECIFICATION FOLLOWS JIS C 0806 (IEC 60286-3).
- MAKE EMPTY SECTION OF LEADER AND END ON EACH END OF THE TAPE.
- TOP TAPE SHALL NOT STICK OUT FROM EMBOSS TAPE.
- TOP TAPE SHALL NOT COVER FEED HOLE.

NO.	DESCRIPTION	MATERIAL	FINISH , REMARKS
8	PACKING LABEL	-	-
7	REEL	PS	ANTI-STATIC TYPE BLACK
6	TOP TAPE	PET t=0.062 TRANSPARENCY	ANTI-STATIC TYPE
5	EMBOSS TAPE	PS TRANSPARENCY	ANTI-STATIC TYPE

ANGLE	±2°	6 OVER 30 MAX.	±0.3	PROJECTION	SERIES No.	CUSTOMER COPY
6 MAX.	±0.2	30 OVER 120 MAX.	±0.5	⊕	R1	
GENERAL TOLERANCE.				TITLE	SCALE	I-PEX
DWG.	DATE			NOVASTACK® 35-HDP PLUG ASS'Y	X:1	
CHK.					UNIT	
APP.					mm	
				DWG. No.	SIZE	
				20697	A3	SHEET 8/8 REV. 6