

ODD NUMBER POS.

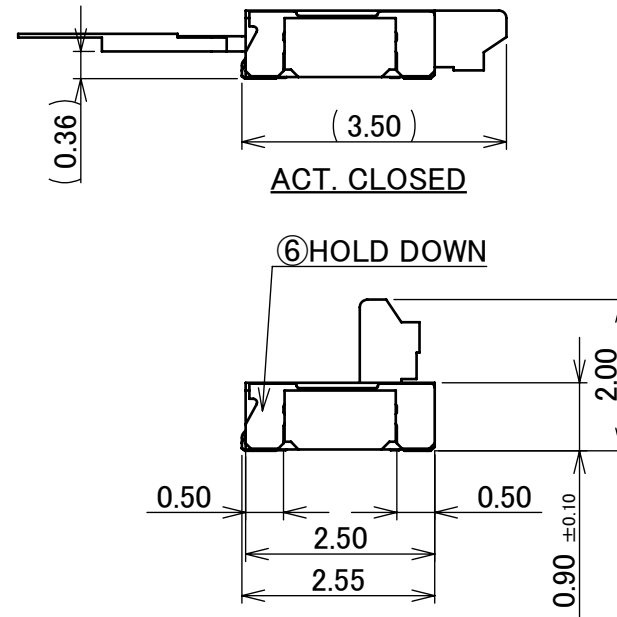

PART NO.	Pos.	A	B	C	D	E	F
20655-011E-01	11P	6.00	2.40	3.00	4.85	4.20	5.50
◆20655-029E-01	29P	11.40	7.80	8.40	10.25	9.60	10.90
◆20655-031E-01	31P	12.00	8.40	9.00	10.85	10.20	11.50
◆20655-035E-01	35P	13.20	9.60	10.20	12.05	11.40	12.70
◆20655-037E-01	37P	13.80	10.20	10.80	12.65	12.00	13.30
◆20655-041E-01	41P	15.00	11.40	12.00	13.85	13.20	14.50
20655-045E-01	45P	16.20	12.60	13.20	15.05	14.40	15.70
◆20655-047E-01	47P	16.80	13.20	13.80	15.65	15.00	16.30
◆20655-051E-01	51P	18.00	14.40	15.00	16.85	16.20	17.50
◆20655-053E-01	53P	18.60	15.00	15.60	17.45	16.80	18.10
◆20655-057E-01	57P	19.80	16.20	16.80	18.65	18.00	19.30

◆MARK MEANS NOT AVAILABLE.

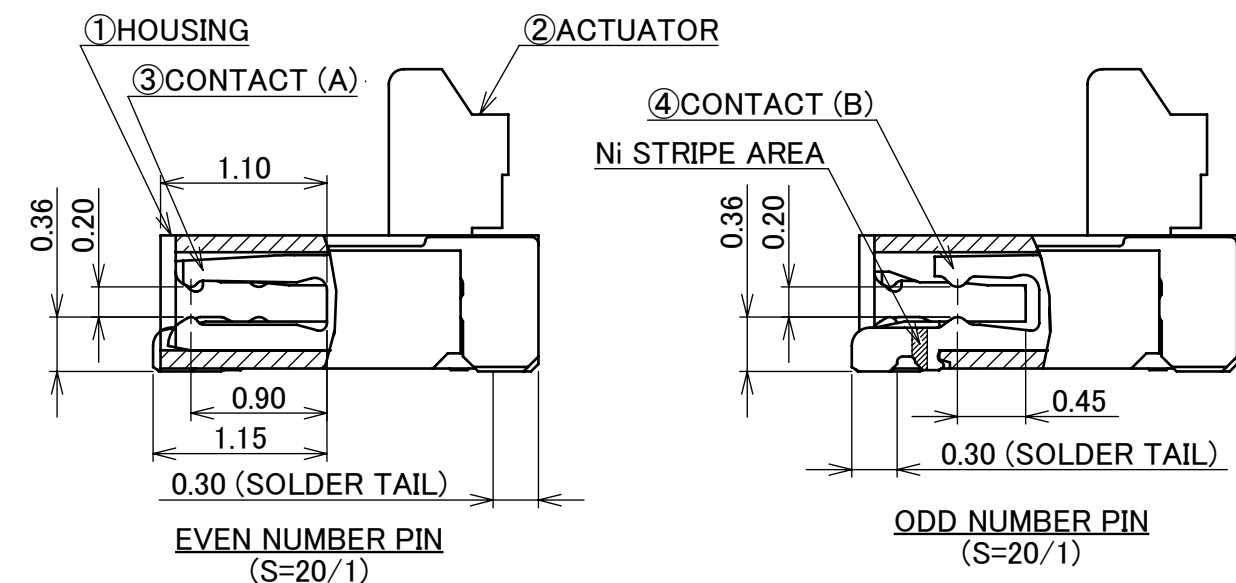
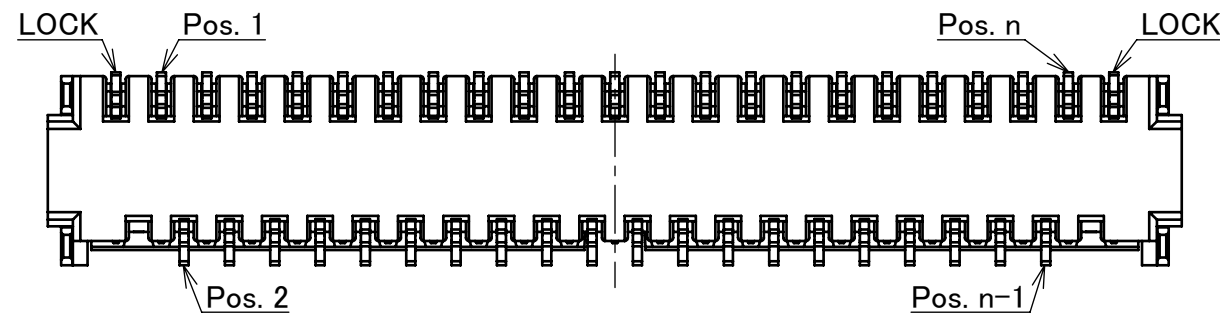
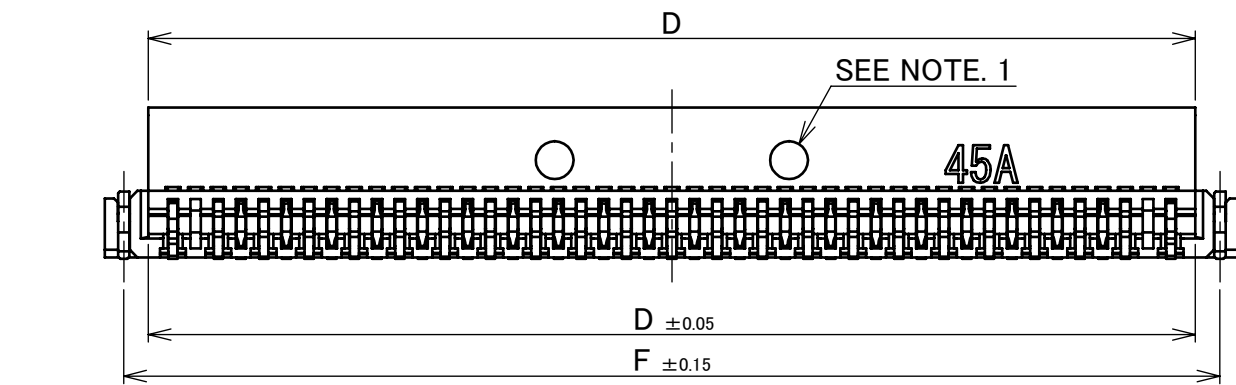
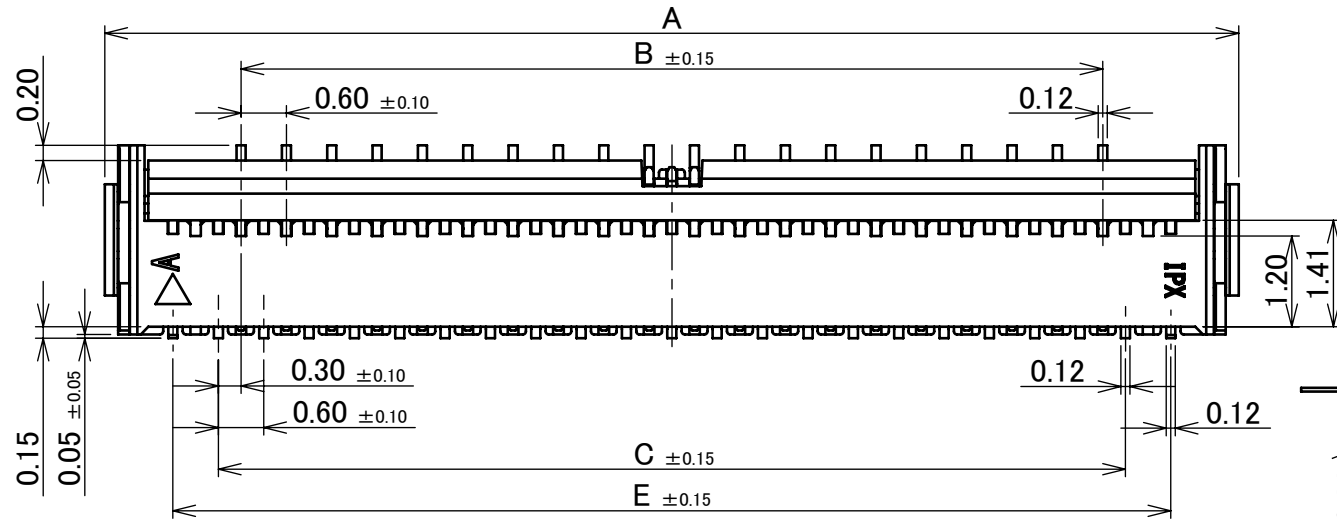
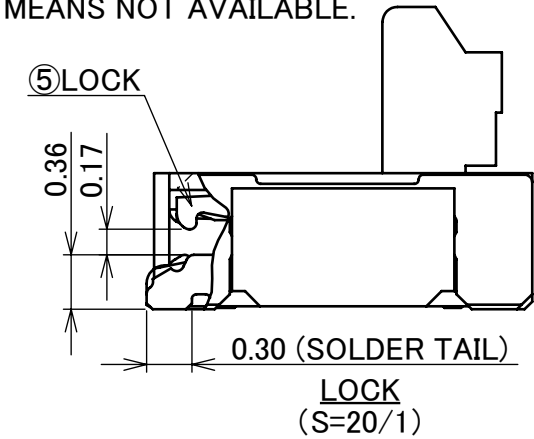

NOTES.

- THIS DENT SHAPE IS PURPOSED FOR GOOD INJECTION QUALITY. THIS DENT SHAPE WILL NOT AFFECT CONNECTR FUNCTION. DENT SHAPE SHOWN ON DRAWING IS JUST FOR REFERENCE. DENT SHAPE AND QUANTITY MIGHT CHABGE FROM DIFFERENT PIN COUNT AND DIFFERENT TOOLING.
- CONTACT POINT: TOP AND BOTTOM CONTACT



VISIT OUR WEBSITE FOR LATEST VERSIONS OF INSTRUCTION MANUAL NO. HIM-12007 TO HANDLE THE PRODUCT PROPERLY AND SAFELY.

TABLE 1

PART NO.	FINISH
20655-0**E-01	CONTACT AREA : Au 0.10 μm MIN. OVER Ni 1.00 μm MIN. SOLDERING AREA : Au 0.03 μm MIN. OVER Ni 1.00 μm MIN.

NO.	DISCRPTION	MATERIAL	FINISH , REMARKS
6	HOLD DOWN	PHOSPHOR BRONZE	Sn 2~6 μm OVER Ni 1.00 μm MIN.
5	LOCK	PHOSPHOR BRONZE	SOLDERLING AREA: Au 0.03 μm MIN. OVER Ni 1.00 μm MIN.
4	CONTACT (B)	PHOSPHOR BRONZE	SEE TABLE 1, WITH Ni STRIPE
3	CONTACT (A)	PHOSPHOR BRONZE	SEE TABLE 1
2	ACTUATOR	LCP	UL94V-0, BEIGE
1	HOUSNIG	LCP	UL94V-0, BEIGE

REV.	ECN	BY	DATE	APP.	APP.	DWG. No.	20655	SIZE	SHEET	REV.
9	Z201273	M.M	Dec./10/'20	Y.S	ANGLE ±2°	6 OVER 30 MAX.	±0.3	PROJECTION	SERIES No. R0	CUSTOMER COPY
8	Z191376	M.M	Oct./15/'19	H.I	6 MAX. ±0.2	30 OVER 120 MAX.	±0.5	MINIFLEX® 3-BFN	SCALE 10:1	I-PEX
7	Z181440	T.O	Nov./02/'18	H.I	GENERAL TOLERANCE.			L-LK-HD TYPE	UNIT mm	
6	Z181291	T.O	Oct./01/'18	H.I	DWG. Y.Shimada	DATE 2015/01/22			mm	
5	Z170480	H.A	Apr./24/'17	Y.S	CHK. J.Tateishi				SIZE A3	
4	Z161237	H.A	Oct./06/'16	Y.S	APP. E.Kawabe				SHEET 1/7	
REVISION RECORD										REV. 9

EVEN NUMBER POS.

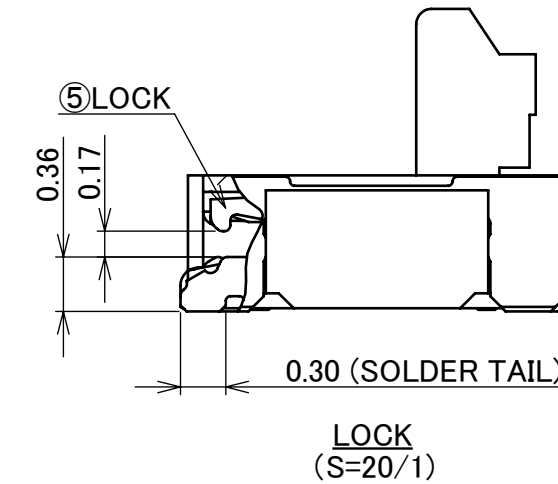
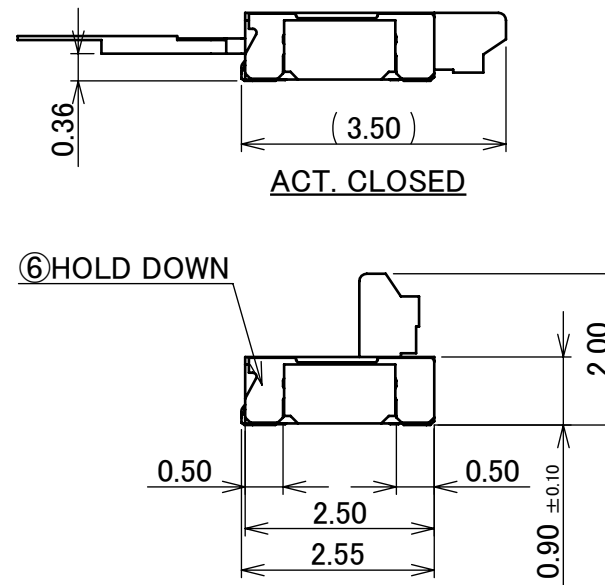
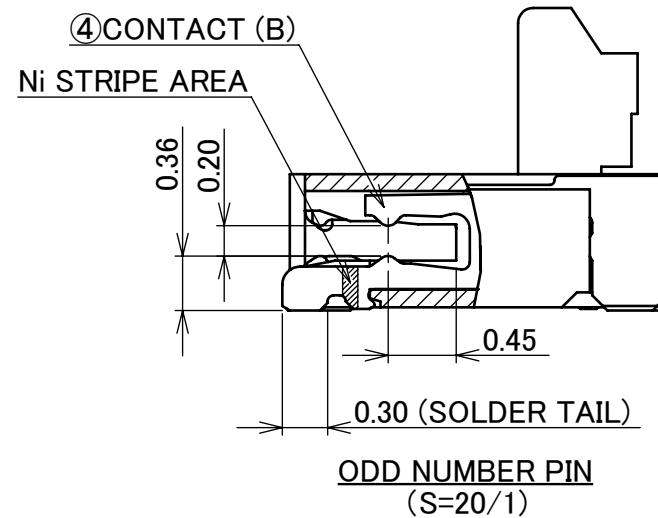
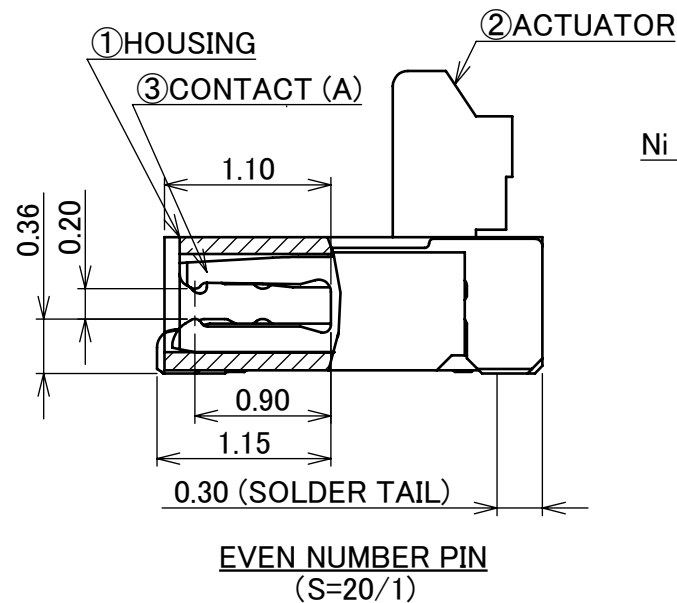
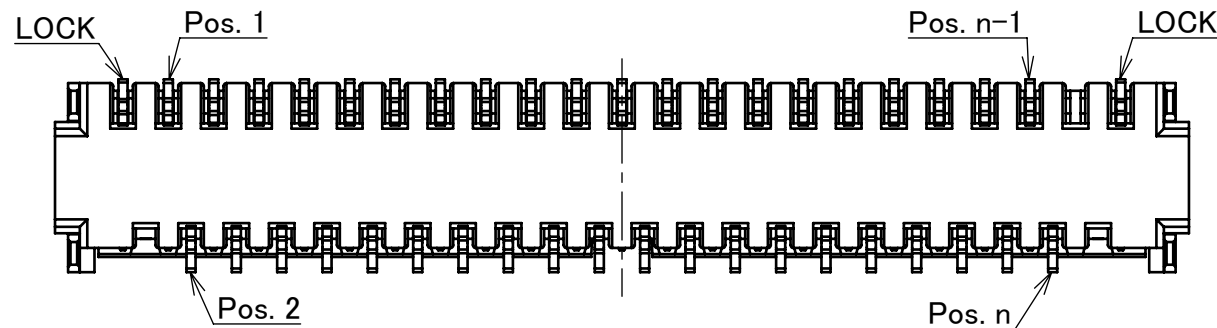
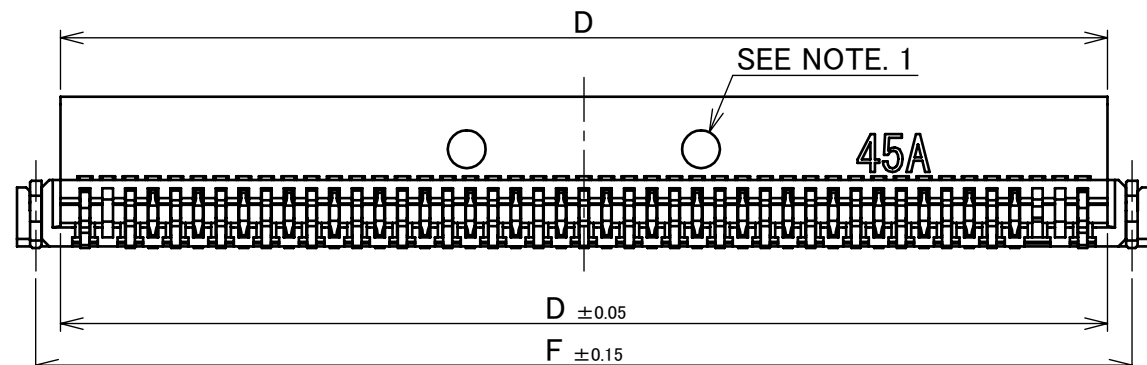
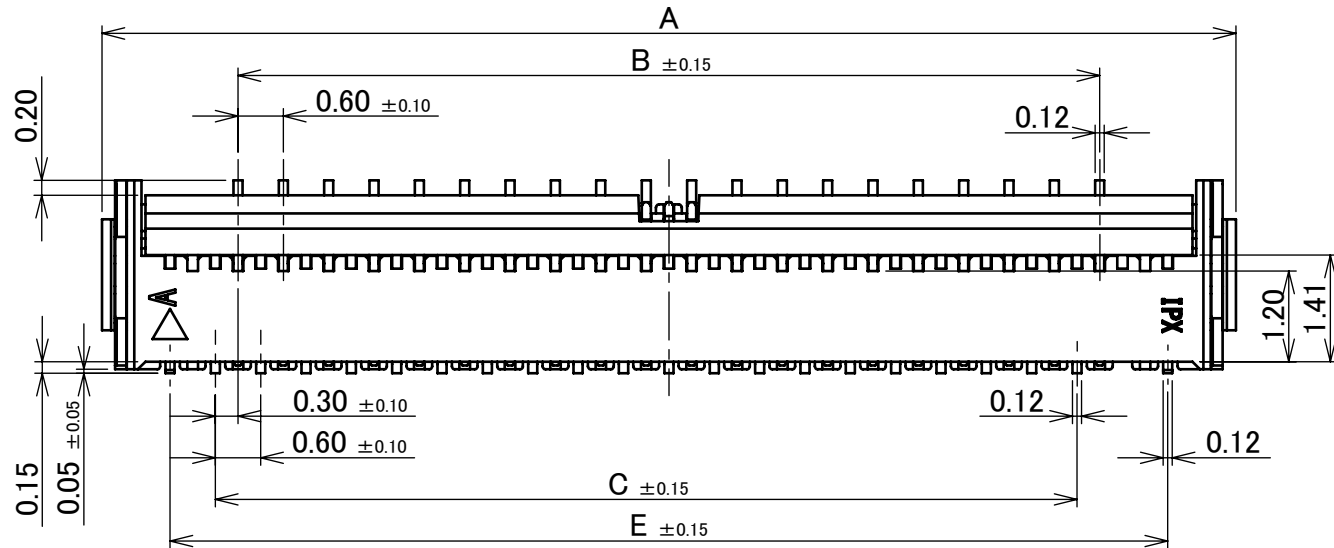

PART NO.	Pos.	A	B	C	D	E	F
◆20655-030E-01	30P	12.00	8.40	8.40	10.85	10.20	11.50
20655-040E-01	40P	15.00	11.40	11.40	13.85	13.20	14.50
◆20655-050E-01	50P	18.00	14.40	14.40	16.85	16.20	17.50

◆MARK MEANS NOT AVAILABLE.

NOTES.

- THIS DENT SHAPE IS PURPOSED FOR GOOD INJECTION QUALITY. THIS DENT SHAPE WILL NOT AFFECT CONNECTR FUNCTION. DENT SHAPE SHOWN ON DRAWING IS JUST FOR REFERENCE. DENT SHAPE AND QUANTITY MIGHT CHABGE FROM DIFFERENT PIN COUNT AND DIFFERENT TOOLING.
- CONTACT POINT: TOP AND BOTTOM CONTACT



CAUTION

VISIT OUR WEBSITE FOR LATEST VERSIONS OF INSTRUCTION MANUAL NO. HIM-12007 TO HANDLE THE PRODUCT PROPERLY AND SAFELY.

ANGLE	±2°	6 OVER 30 MAX.	±0.3	PROJECTION	SERIES No.	CUSTOMER COPY	
	6 MAX.	±0.2	30 OVER 120 MAX.	±0.5	R0		
GENERAL TOLERANCE.				TITLE	SCALE	I-PEX	
DWG.	DATE			MINIFLEX® 3-BFN	10:1		
CHK.				L-LK-HD TYPE	UNIT		
APP.				DWG. No.	mm		
				20655	SIZE	SHEET	REV.
					A3	2/7	9

ITEMS	SPECIFICATION
RATING VOLTAGE	50V AC/DC (PER CONTACT)
RATING AMPERAGE	0.3A DC (PER CONTACT)
OPERATING TEMPERATURE	233~358K(-40°C~85°C)
OPERATING HUMIDITY	20~80%RH (NON-CONDENSING)
CONTACT RESISTANCE	INITIAL : 60mohm MAX. / AFTER TEST : \triangleleft 40mohm MAX.
INSULATION RESISTANCE	100Mohm MIN.
DIELECTRIC WITHSTANDING VOLTAGE	AC250V 1min
DURABILITY	20 CYCLES
ACTUATOR LOCKING FORCE (INITIAL / 20TH CYCLES)	INITIAL / 20 CYCLES 0.21N (21gf) \times (n + 2) MAX.
ACTUATOR UNLOCKING FORCE (INITIAL / 20TH CYCLES)	INITIAL / 20 CYCLES 0.014N (1.4gf) \times (n + 2) MIN.
FPC RETENTION FORCE (INITIAL / AFTER TEST)	INITIAL: 0.13N (13gf) \times n + 1.0N MIN. / AFTER TEST: 0.10N (10gf) \times n + 1.0N MIN.
COPLANARITY	0.10 MAX.
PRODUCT SPECIFICATION	PRS-2077
TEST REPORT	TR-15027
PACKING STANDARD	PST-15018
INSTRUCTION MANUAL	HIM-12007
APPEARANCE CRITERIA No.	QLS-A***

※ "n" IS THE NUMBER OF PIN

ANGLE	$\pm 2^\circ$	6 OVER 30 MAX.	± 0.3	PROJECTION 	SERIES No. R0	CUSTOMER COPY		
	6 MAX.	± 0.2	30 OVER 120 MAX.			± 0.5	SCALE	I-PEX
GENERAL TOLERANCE.				TITLE	5:1	UNIT mm		
DWG.	DATE			MINIFLEX [®] 3-BFN L-LK-HD TYPE	SIZE			
CHK.				DWG. No.	20655	REV.	9	
APP.								

ODD NUMBER POS.

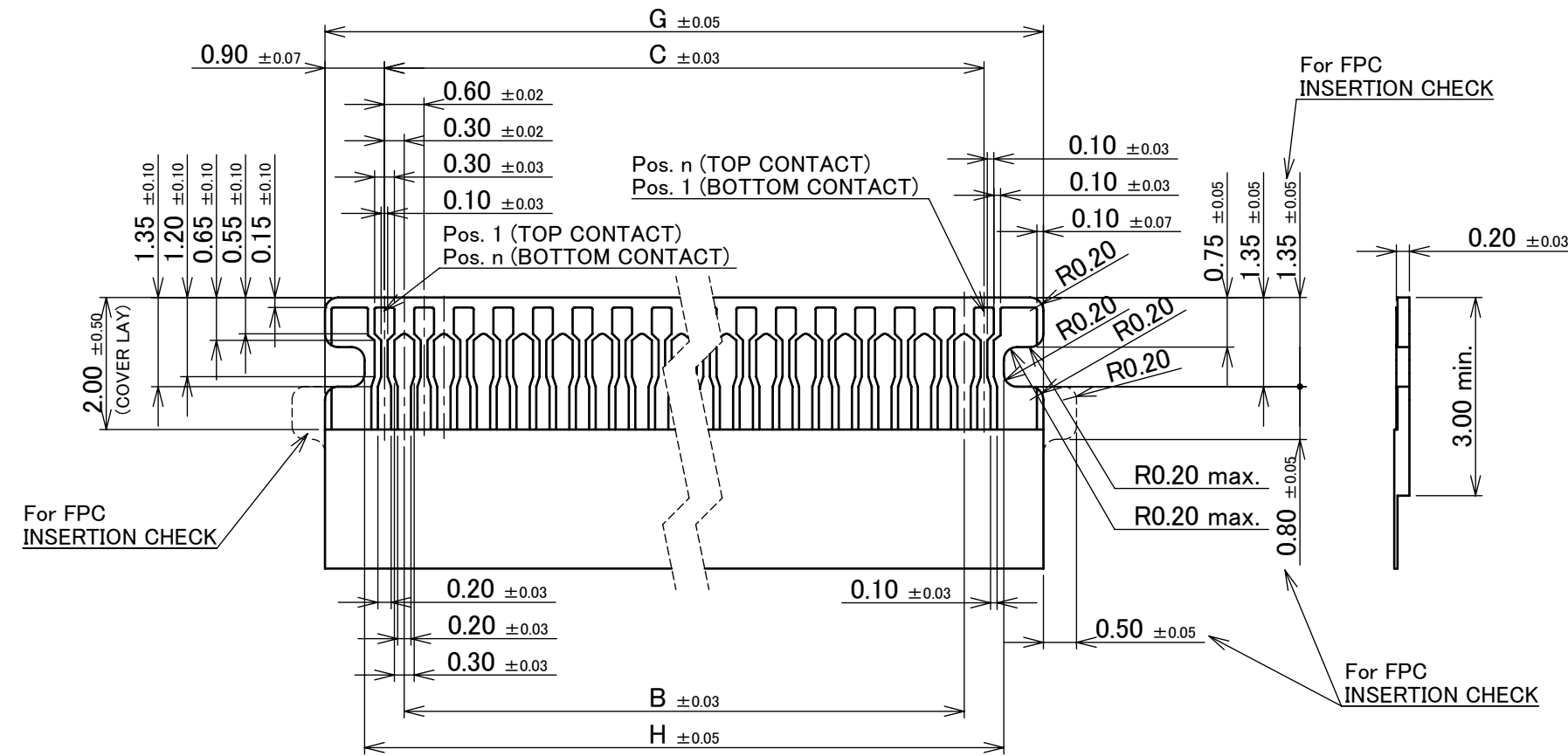

RECOMMENDED FPC LAYOUT

PART NO.	Pos.	B	C	E	G	H	J
20655-011E-01	11P	2.40	3.00	4.20	4.80	3.60	5.65
◆20655-029E-01	29P	7.80	8.40	9.60	10.20	9.00	11.05
◆20655-031E-01	31P	8.40	9.00	10.20	10.80	9.60	11.65
◆20655-035E-01	35P	9.60	10.20	11.40	12.00	10.80	12.85
◆20655-037E-01	37P	10.20	10.80	12.00	12.60	11.40	13.45
◆20655-041E-01	41P	11.40	12.00	13.20	13.80	12.60	14.65
20655-045E-01	45P	12.60	13.20	14.40	15.00	13.80	15.85
◆20655-047E-01	47P	13.20	13.80	15.00	15.60	14.40	16.45
◆20655-051E-01	51P	14.40	15.00	16.20	16.80	15.60	17.65
◆20655-053E-01	53P	15.00	15.60	16.80	17.40	16.20	18.25
◆20655-057E-01	57P	16.20	16.80	18.00	18.60	17.40	19.45

◆MARK MEANS NOT AVAILABLE.

- NOTES
3. MATERIAL
 COVER FILM : PI
 CONDUCTOR : COPPER(RARE)
 BASE FILM : PI
 STIFFENER : PI
 ADHESIVE : THERMOSETTING ADHESIVE
 4. FINISH
 Au OVER Ni UNDER PLATING.
 5. SOLDER RESIST SHALL BE APPLIED TO PREVENT SHORT CIRCUITS WHEN PLACING SIGNAL LINES ON GROUND AREA.

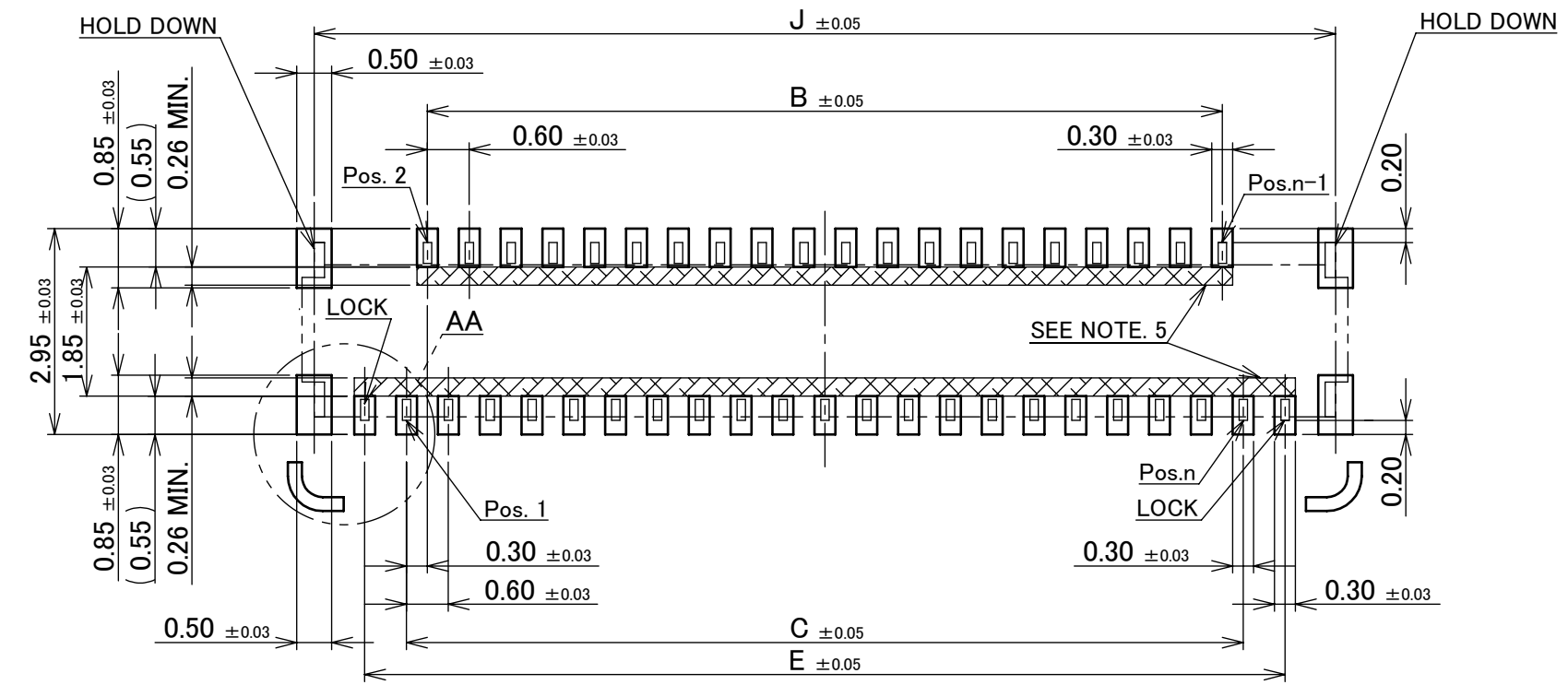

RECOMMENDED PCB LAYOUT & METAL MASK LAYOUT
 METAL MASK THICKNESS : t=0.12 mm

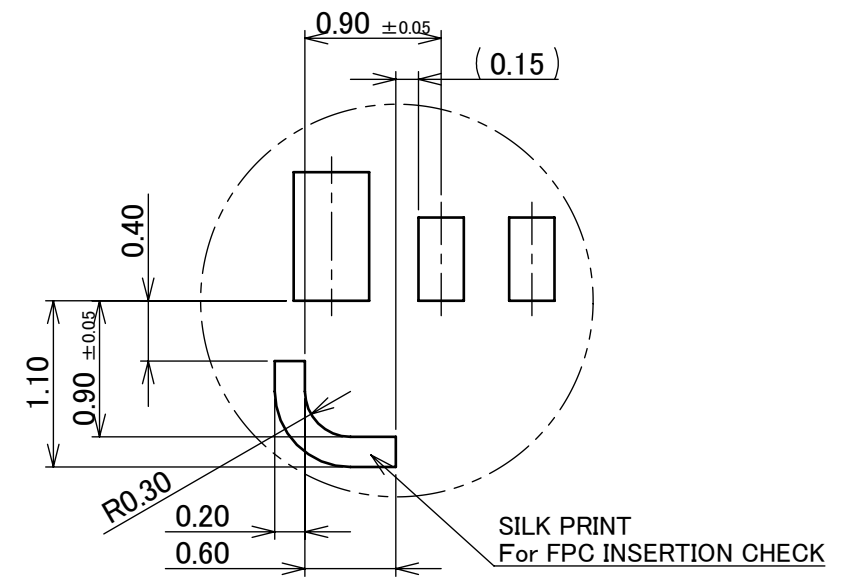

DETAIL AA
 (S=20/1)

ANGLE	±2°	6 OVER 30 MAX.	±0.3	PROJECTION	SERIES No.	CUSTOMER COPY	
	6 MAX.	±0.2	30 OVER 120 MAX.	⊕	R0		
GENERAL TOLERANCE.				TITLE	SCALE	I-PEX	
DWG.	DATE			MINIFLEX® 3-BFN	10:1		
CHK.				L-LK-HD TYPE	UNIT		
APP.				DWG. No.	mm		
				20655	SIZE	SHEET	REV.
					A3	4/7	9

EVEN NUMBER POS.

PART NO.	Pos.	B	C	E	G	H	J
◆20655-030E-01	30P	8.40	8.40	10.20	10.80	9.60	11.65
20655-040E-01	40P	11.40	11.40	13.20	13.80	12.60	14.65
◆20655-050E-01	50P	14.40	14.40	16.20	16.80	15.60	17.65

◆MARK MEANS NOT AVAILABLE.

- NOTES
 3. MATERIAL
 COVER FILM : PI
 CONDUCTOR : COPPER(RARE)
 BASE FILM : PI
 STIFFENER : PI
 ADHESIVE : THERMOSETTING ADHESIVE
 4. FINISH
 Au OVER Ni UNDER PLATING.
 5. SOLDER RESIST SHALL BE APPLIED TO PREVENT SHORT CIRCUITS WHEN PLACING SIGNAL LINES ON GROUND AREA.

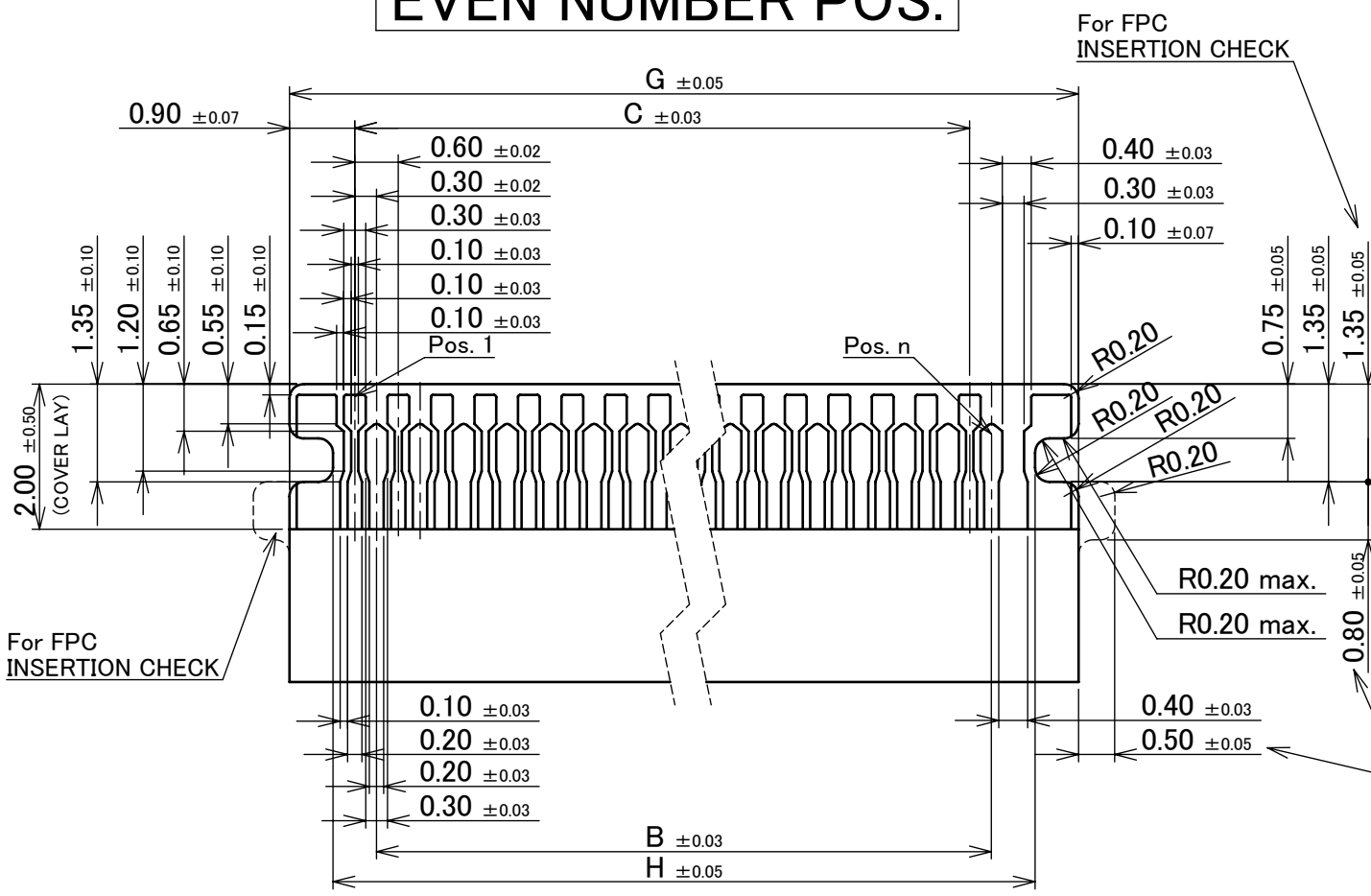

RECOMMENDED FPC LAYOUT (FOR TOP CONTACT)

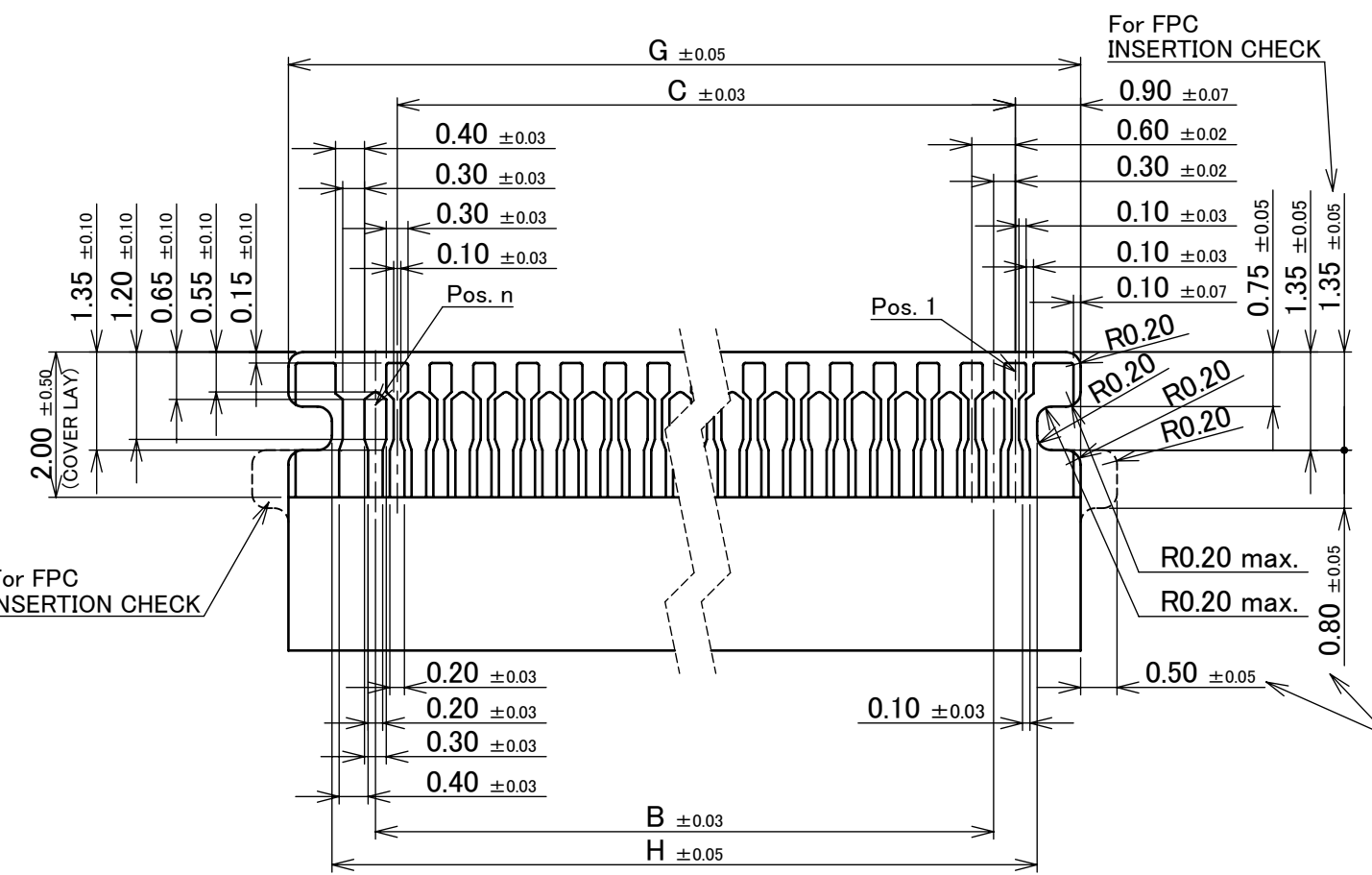

RECOMMENDED FPC LAYOUT (FOR BOTTOM CONTACT)

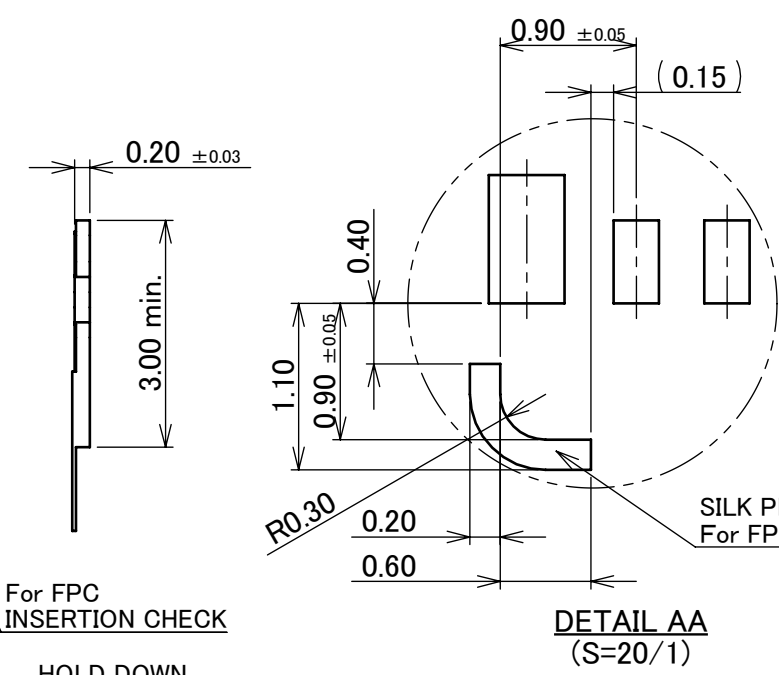

DETAIL AA (S=20/1)

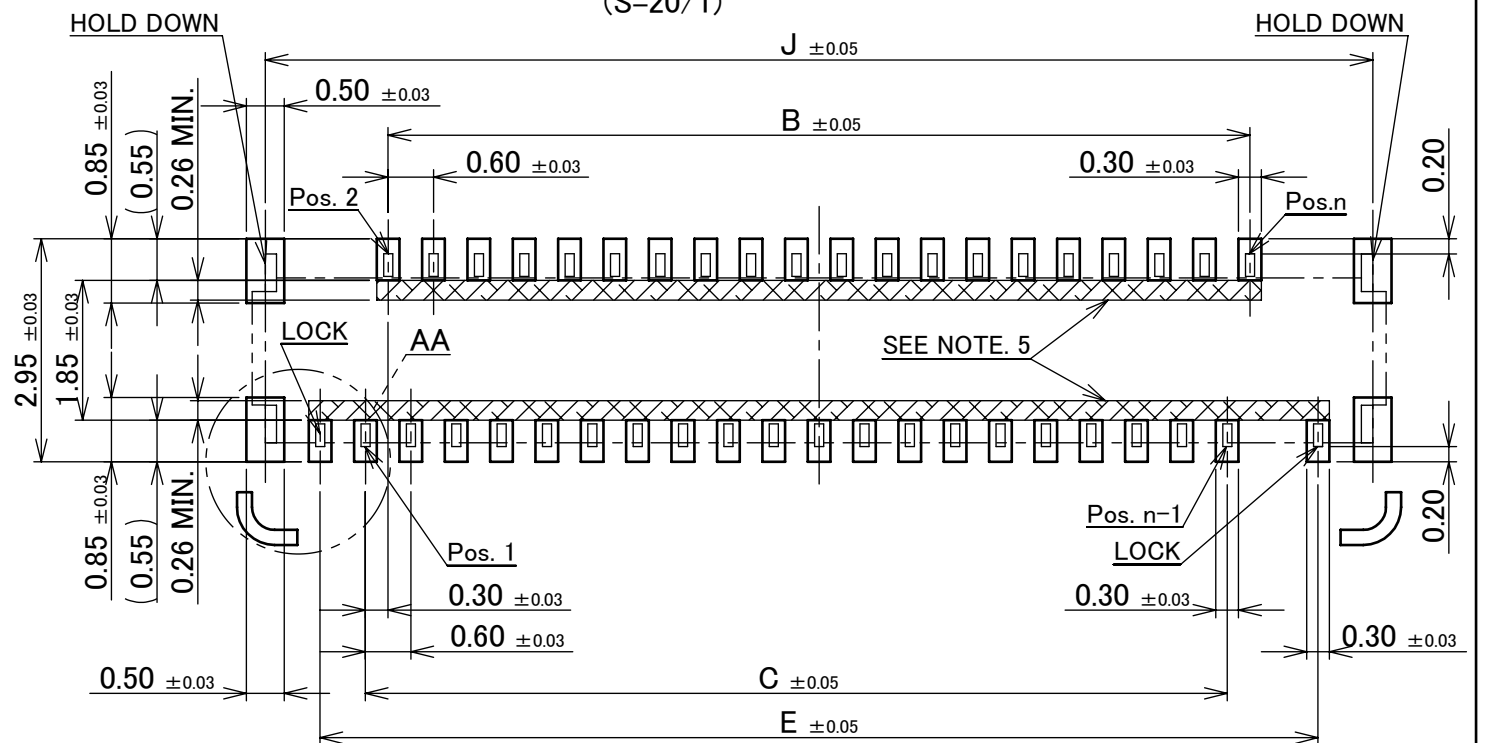

RECOMMENDED PCB LAYOUT & METAL MASK LAYOUT
 METAL MASK THICKNESS : t=0.12 mm

ANGLE	±2°	6 OVER 30 MAX.	±0.3	PROJECTION ①	SERIES No. R0	CUSTOMER COPY			
	6 MAX.	±0.2	30 OVER 120 MAX.			±0.5	SCALE 10:1	I-PEX	
GENERAL TOLERANCE.				TITLE	UNIT	mm			
DWG.	DATE			MINIFLEX® 3-BFN	SIZE	SHEET	REV.		
CHK.				L-LK-HD TYPE	A3	5/7	9		
APP.				DWG. No.	20655				

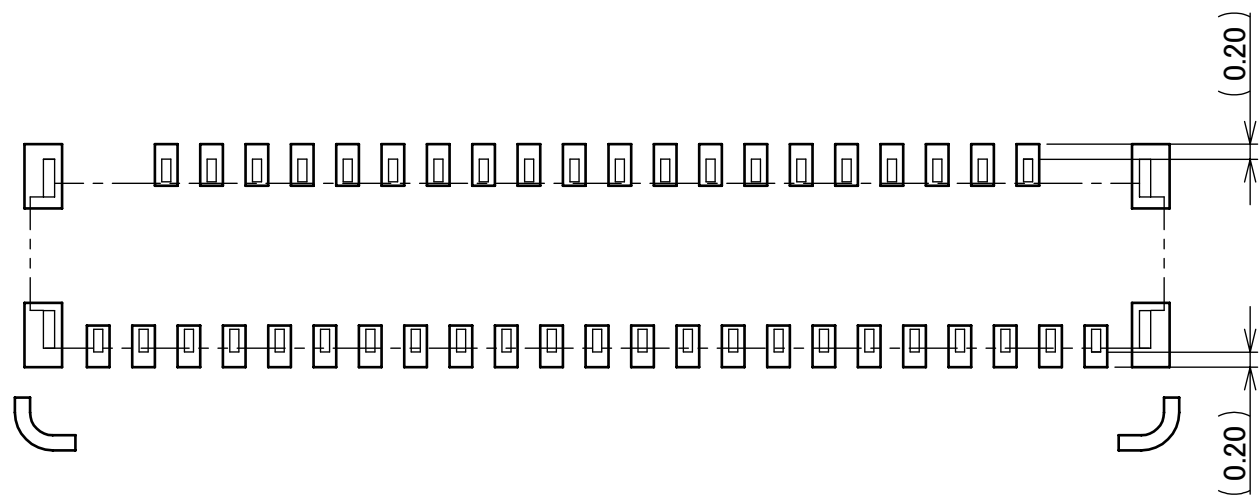

CONNECTOR ON RECOMMENDED PCB LAYOUT

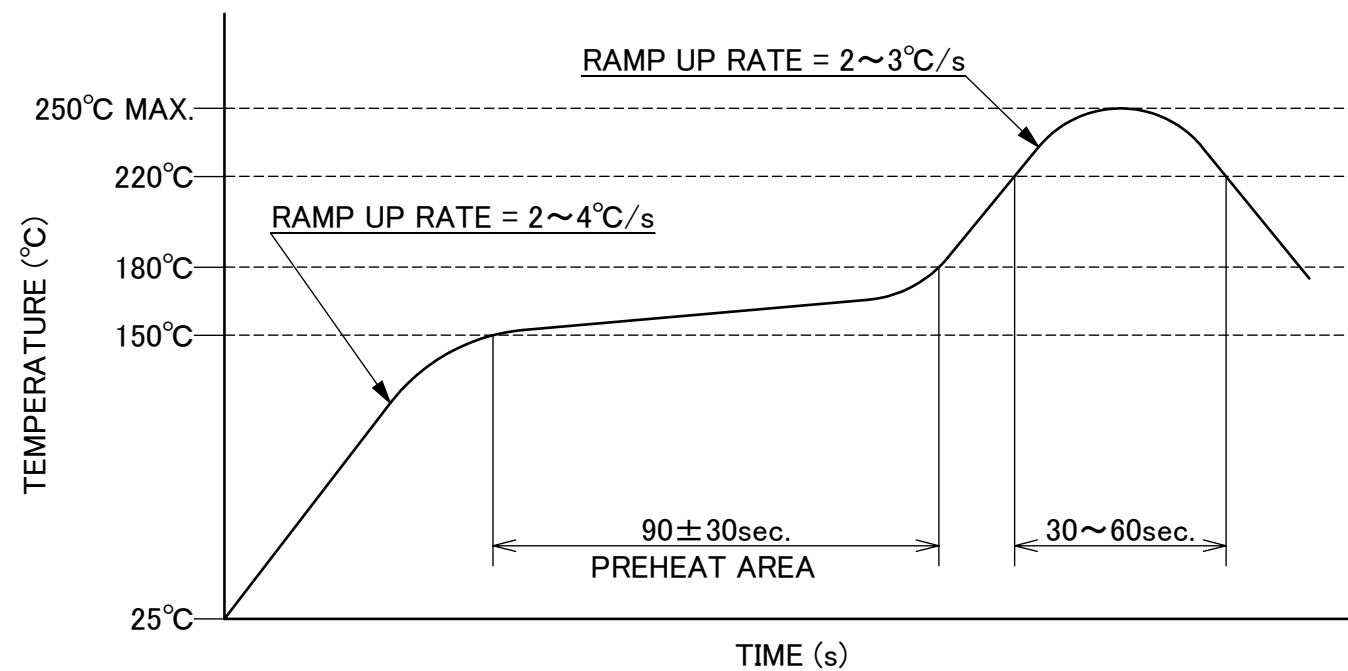

REFLOW TEMPERATURE PROFILE
 SENJU METAL INDUSTRY CO., LTD. : M705-SHF(Sn96.5 Ag3.0 Cu0.5)

ANGLE	±2°	6 OVER 30 MAX.	±0.3	PROJECTION 	SERIES No. R0	CUSTOMER COPY		
6 MAX.	±0.2	30 OVER 120 MAX.	±0.5					
GENERAL TOLERANCE.				TITLE MINIFLEX® 3-BFN L-LK-HD TYPE	SCALE 10:1	UNIT I-PEX		
DWG.	DATE							
CHK.								
APP.								
				DWG. No.	20655	SIZE A3	SHEET 6/7	REV. 9

DEVICE P/N	K	L	M	N	P	Q	QTY. PER EMBOSS REEL (PIECES / REEL)	QTY. PER PACKING CARTON (REELS / CARTON)
20655-011E-01	16.0	13.5	7.50	6.20	4.00	2.75	4,000 / REEL	7 / CARTON = 28,000
20655-040E-01	24.0	21.5	11.50	15.40	8.00	2.95		5 / CARTON = 20,000
20655-045E-01			16.60					

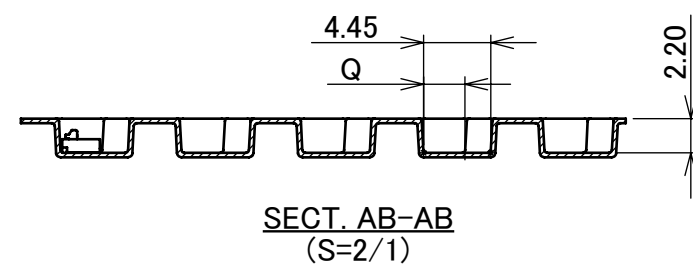
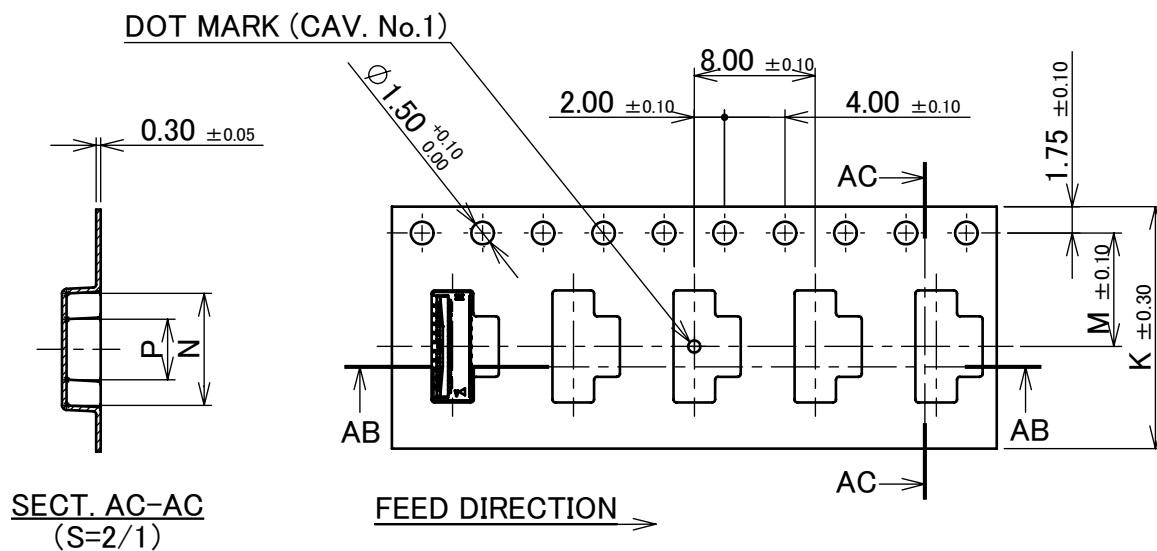
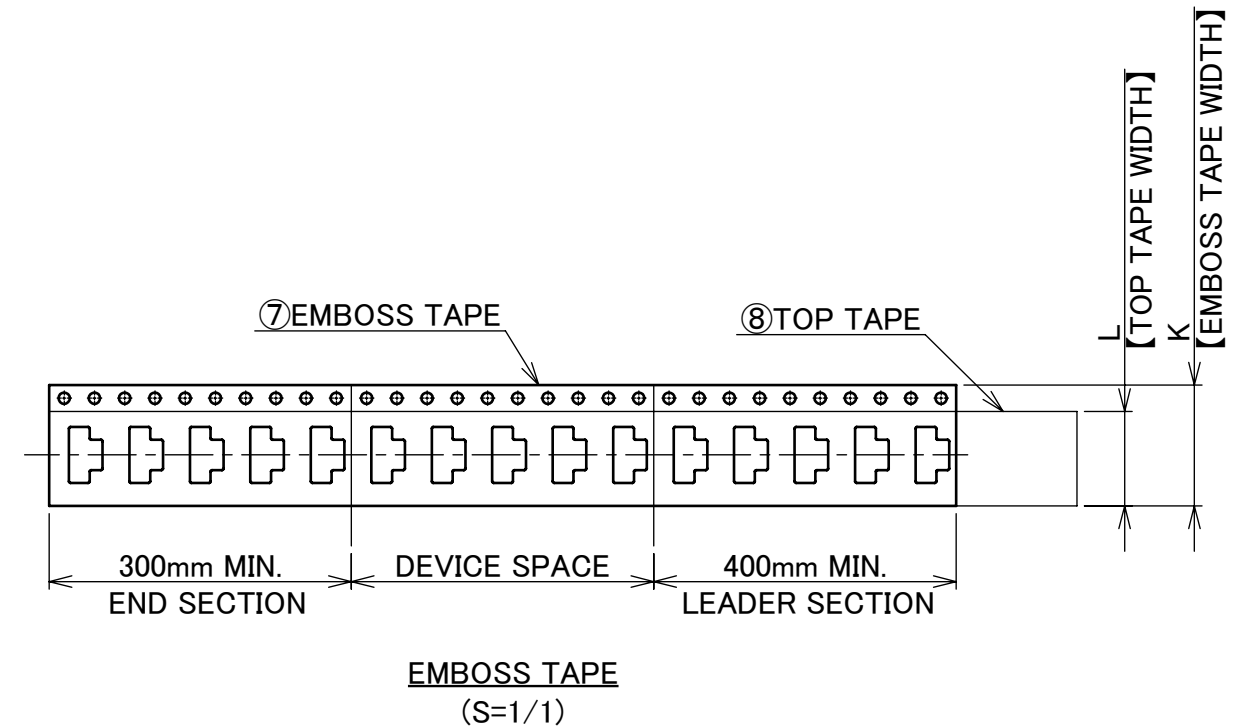
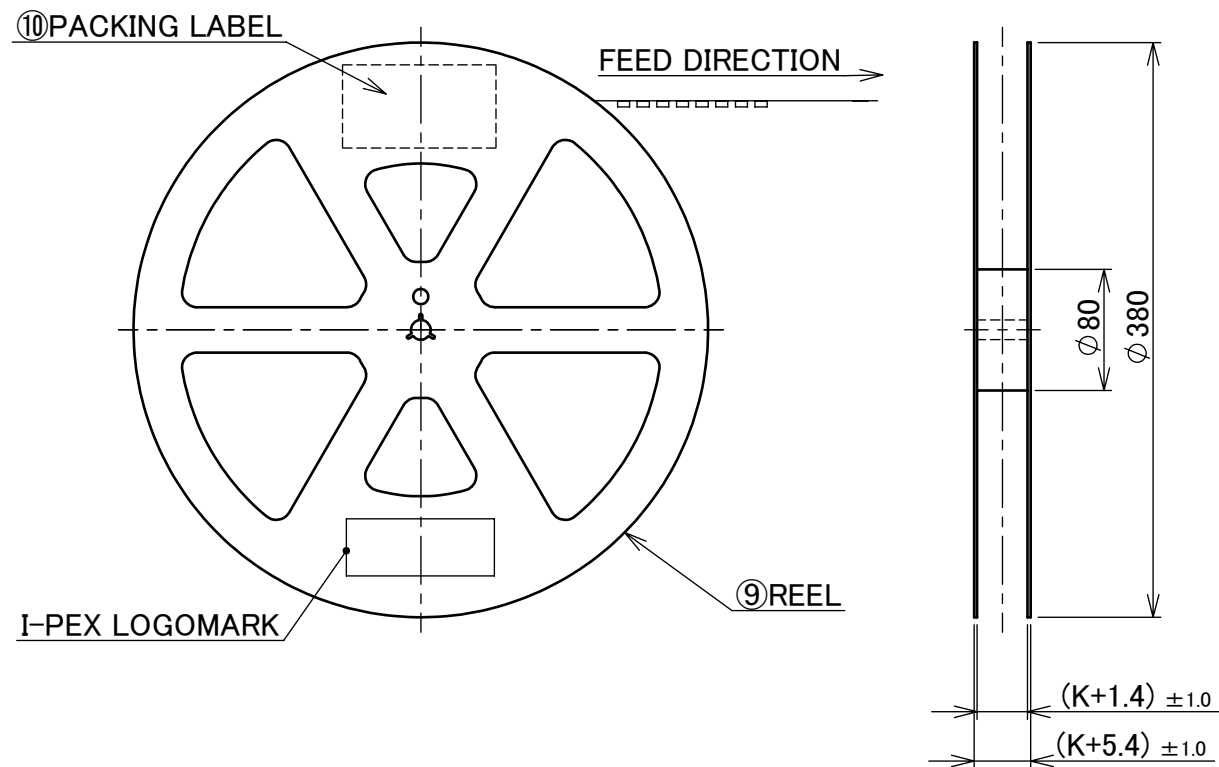

- NOTES.
6. TAPING SPECIFICATION FOLLOWS JIS C 0806 (IEC 60286-3).
7. MAKE EMPTY SECTION OF LEADER AND END ON EACH END OF THE TAPE.
8. TOP TAPE SHALL NOT STICK OUT FROM EMBOSS TAPE.
9. TOP TAPE SHALL NOT COVER FEED HOLE.

NO.	DISCRIPTION	MATERIAL	FINISH , REMARKS
10	PACKING LABEL	-	-
9	REEL	PS	BLACK
8	TOP TAPE	PET $t=0.062$ TRANSPARENCY	ANTI-STATIC TYPE HEAT WELDING TYPE
7	EMBOSS TAPE	PS $t=0.3$ TRANSPARENCY	ANTI-STATIC TYPE

ANGLE	$\pm 2^\circ$	6 OVER 30 MAX.	± 0.3	PROJECTION	SERIES No.	CUSTOMER COPY		
6 MAX.	± 0.2	30 OVER 120 MAX.	± 0.5		R0			
GENERAL TOLERANCE.				TITLE	SCALE		UNIT	
DWG.	DATE			MINIFLEX® 3-BFN L-LK-HD TYPE	1:5		I-PEX	
CHK.					mm			
APP.				DWG. No.	20655	SIZE	SHEET	REV.
						A3	7/7	9