

Recommended P/N AHR001-01-A02-0

PART No.
AHR001-01-*0*-0

AHR001-01-*0*-0

IT IS CODE No. THAT I-PEX USES.
 1 : OUTPUT FORM RS-422 , WITH USB
 2 : OUTPUT FORM RS-422 , WITHOUT USB
 A : WITH FLOATING MECHANISM
 B : WITHOUT FLOATING MECHANISM
 ES-Gripper Body



< RANGE OF MOTION >
 *WITH FLOATING MECHANISM

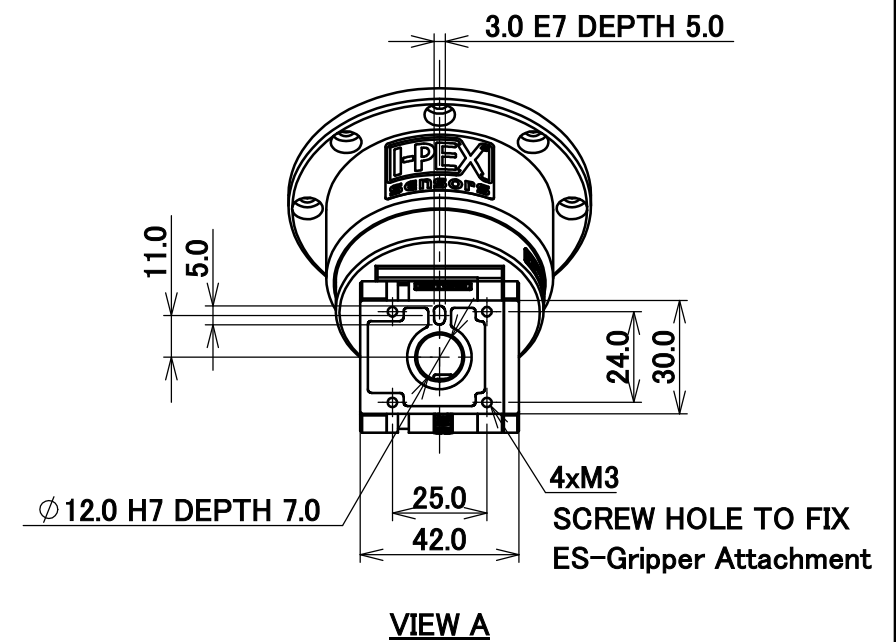
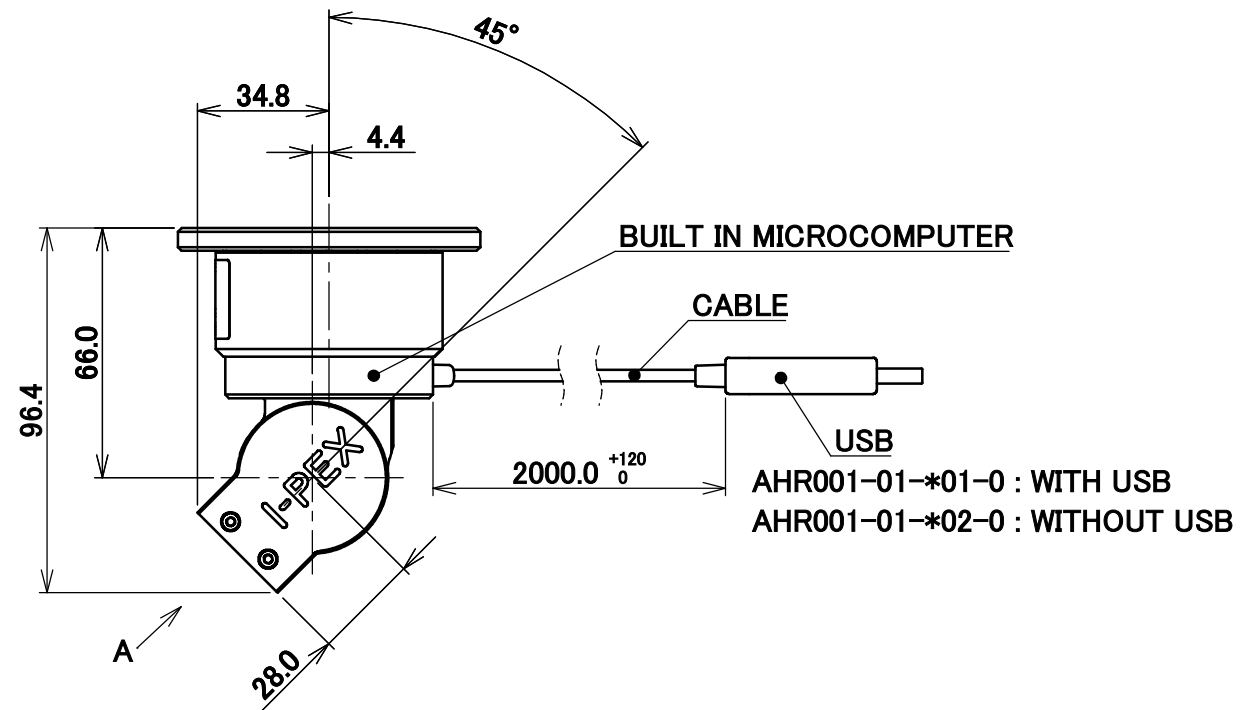
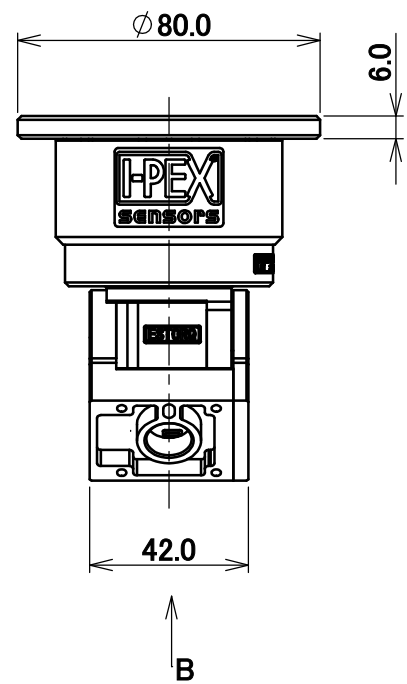
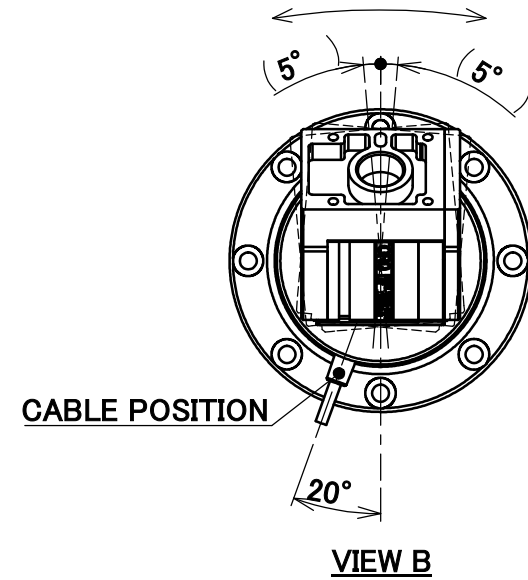
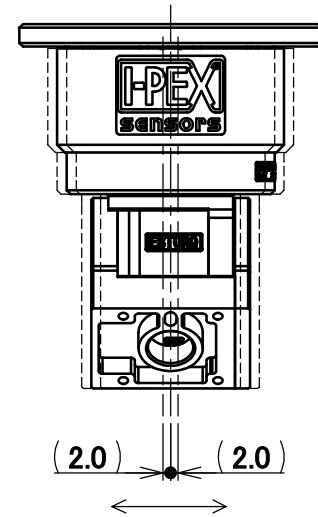
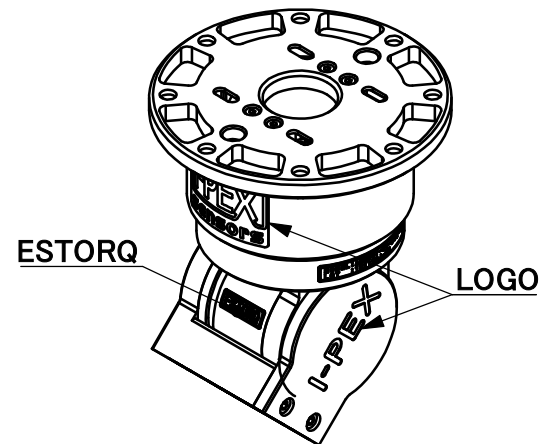
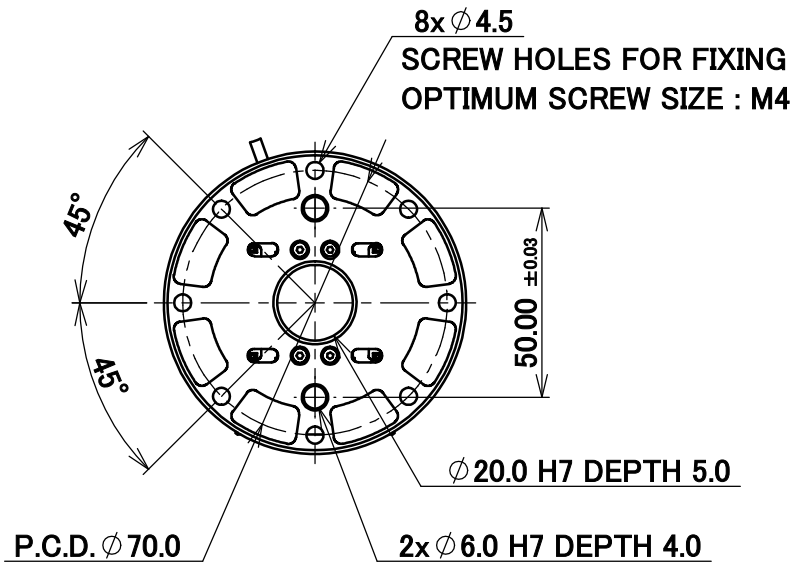

NOTES.
 1. MATERIAL
 FRAMEWORK : ALUMINIUM
 2. WEIGHT : APPROXIMATELY 415 g
 3. ES-Gripper Body USES MAGNETIC PARTS.

					ANGLE	±2°	6 OVER 30 MAX.	±0.3	PROJECTION	SERIES No.	CUSTOMER COPY	
						6 MAX.	±0.2	30 OVER 120 MAX.	⊕	-		
					GENERAL TOLERANCE.				TITLE		SCALE	
1	Jul./15/'19	H.T	S.N	S.N	DWG.	T.Nishimura	DATE	2019/02/26	ES-GRIPPER® BODY GENERATION 2 STANDARD TYPE		1:2	
0	Feb./26/'19	T.N			CHK.	N.Sueishi	DATE	2019/02/26			UNIT mm	
REV.	DATE	DWG.	CHK.	APP.	APP.	K.Masuda	DATE	2019/02/26	DWG. No.	AHR001-01	SIZE A3	
REVISION RECORD											SHEET 2/2	REV. 1

Confidential C

DAI-ICHI SEIKO CO., LTD.

