

# MINIFLEX® 3-BFN

低背(高度 = 0.9 mm) · 0.3 mm 間距, 水平插拔, 後鎖式

Product Specifications:		Short Actuator	Long Actuator
Board Pitch (mm)		0.3	
Wiping Length (mm)		Contact A: 0.9 Contact B: 0.45	
Size (mm)	Height	0.90 mm ± 0.10 mm	
	Width	Formula: 0.9 + (0.3 * P)	
	Depth	Open: 2.55	Close: 3.5
Pin counts	Range	13-41 (odd)	33-65 (odd)
	Available	13, 15, 17, 19, 21, 23, 25, 27, 29, 31, 33, 35, 37, 39, 41	33, 35, 39, 41, 45, 49, 51, 55, 57, 61, 65

\*若有規格外 Pin 數需求, 請與當地負責業務窗口聯繫。

## Applicable FPC/FFC:

FPC/FFC Contact Pitch	0.3
FPC/FFC Contact Point	Top and Bottom
FPC/FFC Thickness (mm)	0.2 +/- 0.03



## 防止端子變形的結構

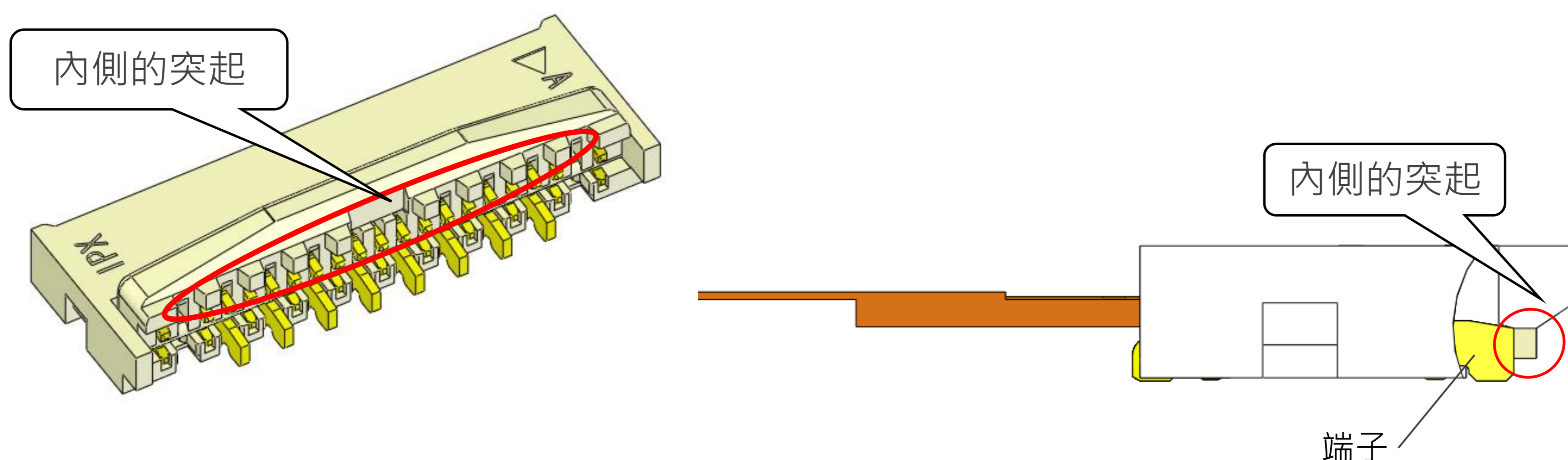

當鋼琴蓋被打開時, 鋼琴蓋內側的突起可以防止指甲碰觸到端子而造成的變形

## 特有的鋼琴蓋形狀設計, 防止半鎖狀況

鋼琴蓋的弧線設計, 能夠引導作業員操作鋼琴蓋中間部位, 這樣可以防止半鎖狀況

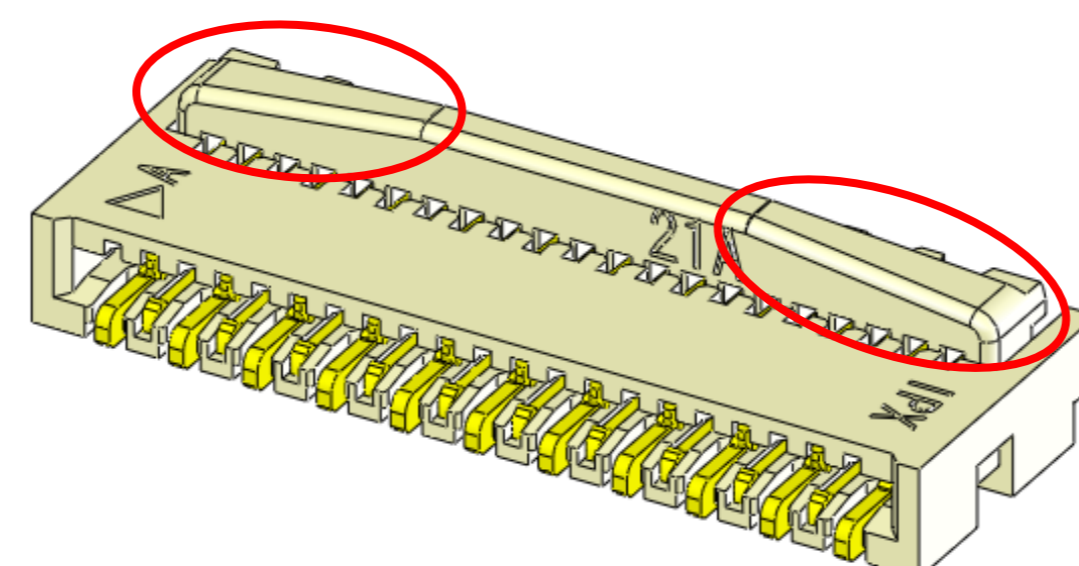

從頂部可以一目了然鋼琴蓋是否處於閉合位置

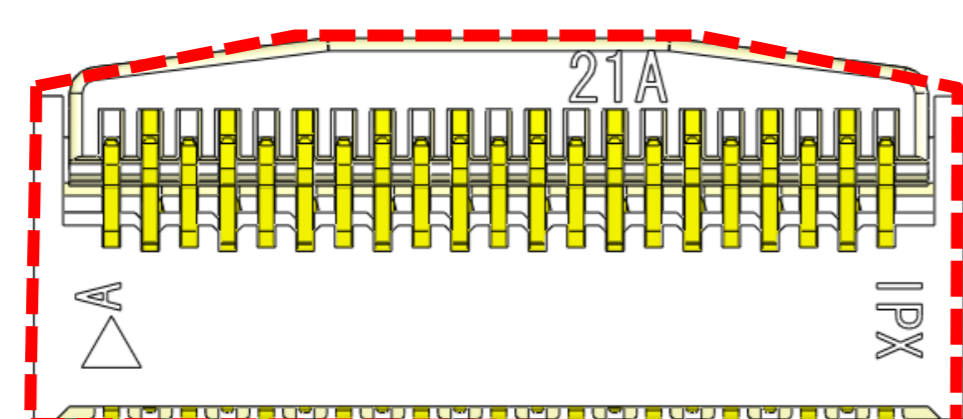

鋼琴蓋  
閉合

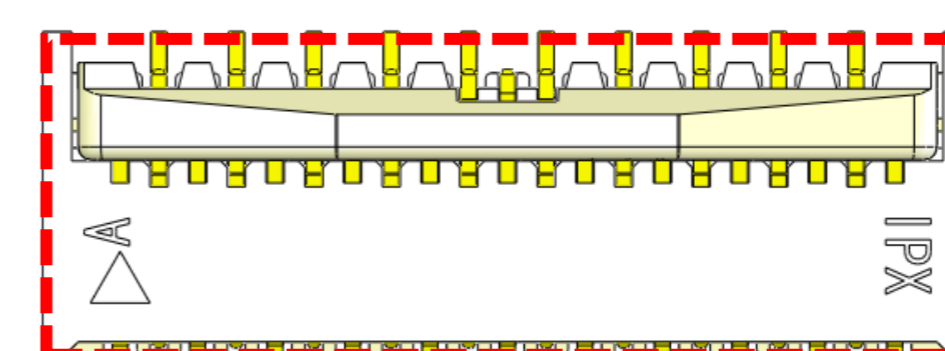

鋼琴蓋  
打開

## 在沒有插入FPC的情況下關閉鋼琴蓋, 連接器仍可使用

在 SMT 加工後, 如果鋼琴蓋在沒有插入 FPC 的情況下意外閉合, 連接器仍可使用

- FPC未插入情況下閉合鋼琴蓋, 其前後的接點間距比較如圖(圖表為 MINIFLEX® 3-BFN 35 pins)

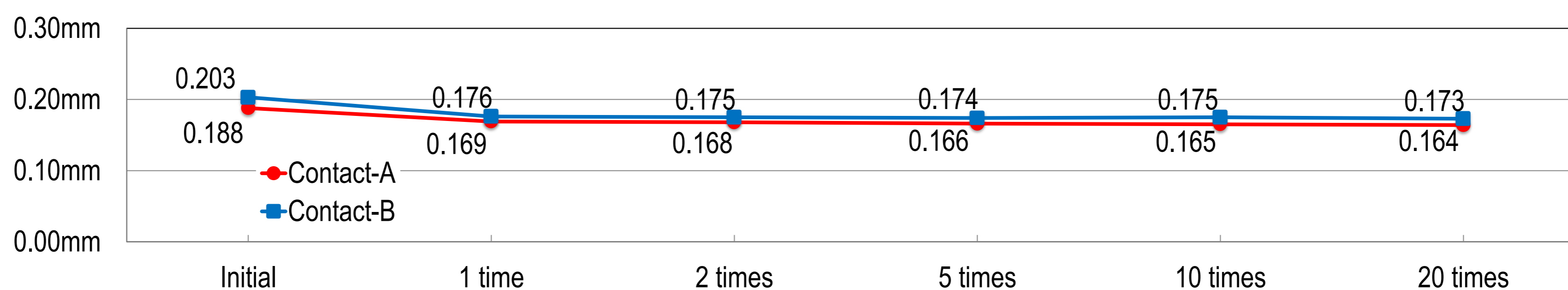

- FPC插入力上升
- FPC保持力無太大變化



# Component Parts Details

## Connector Assembly

Recommended P/N 20527-0\*\*E-01

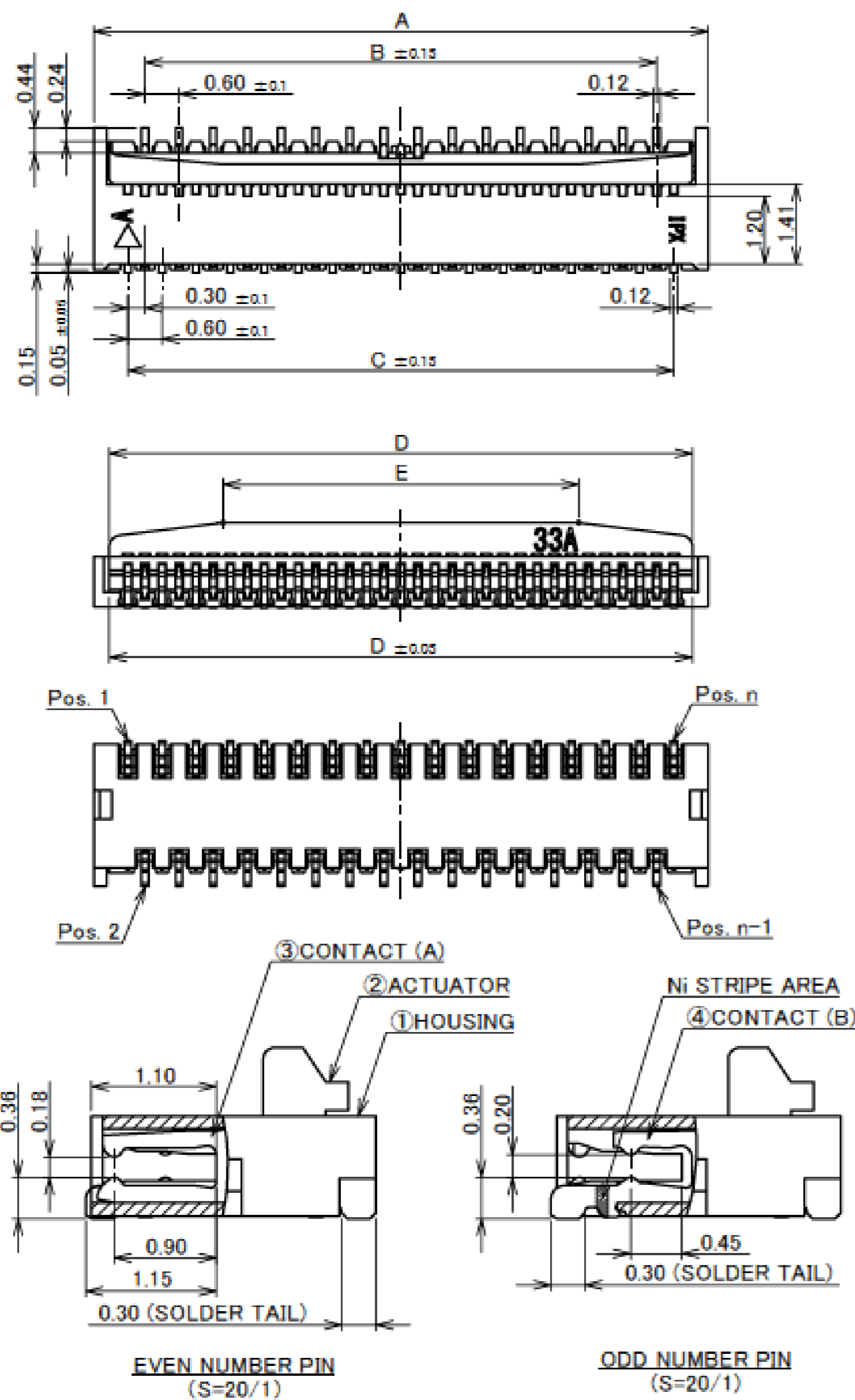

PART NO.	Pos	A	B	C	D	E
20527-013E-0#	13P	4.80	3.00	3.60	4.25	2.25
20527-015E-0#	15P	5.40	3.60	4.20	4.85	2.85
20527-017E-0#	17P	6.00	4.20	4.80	5.45	3.45
20527-019E-0#	19P	6.60	4.80	5.40	6.05	4.05
20527-021E-0#	21P	7.20	5.40	6.00	6.65	2.65
20527-023E-0#	23P	7.80	6.00	6.60	7.25	3.25
20527-025E-0#	25P	8.40	6.60	7.20	7.85	3.85
20527-027E-0#	27P	9.00	7.20	7.80	8.45	4.45
20527-029E-0#	29P	9.60	7.80	8.40	9.05	5.05
20527-031E-0#	31P	10.20	8.40	9.00	9.65	5.65
20527-033E-0#	33P	10.80	9.00	9.60	10.25	6.25
20527-035E-0#	35P	11.40	9.60	10.20	10.85	6.85
20527-037E-0#	37P	12.00	10.20	10.80	11.45	7.45
20527-039E-0#	39P	12.60	10.80	11.40	12.05	8.05
20527-041E-0#	41P	13.20	11.40	12.00	12.65	8.65

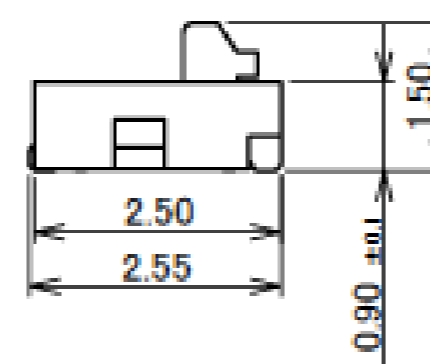
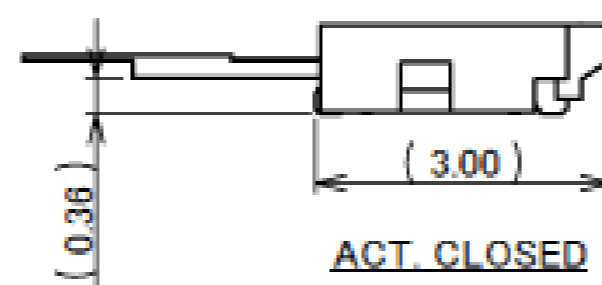

NOTES  
1. CONTACT POINT: TOP AND BOTTOM CONTACT

CAUTION VISIT OUR WEBSITE FOR LATEST VERSIONS OF INSTRUCTION MANUAL NO. HIM-12007 TO HANDLE THE PRODUCT PROPERLY AND SAFELY.

TABLE 1

PART NO.	FINISH
20527-0**E-01	CONTACT AREA : Au 0.10 μm MIN. OVER Ni 1.00 μm MIN. SOLDERING AREA : Au 0.03 μm MIN. OVER Ni 1.00 μm MIN.
20527-0**E-02	CONTACT AREA : Au 0.254 μm MIN. OVER Ni 1.00 μm MIN. SOLDERING AREA : Au 0.03 μm MIN. OVER Ni 1.00 μm MIN.

NO.	DISCRIPTION	MATERIAL	FINISH, REMARKS
4	CONTACT (B)	PHOSPHOR BRONZE	SEE TABLE 1, WITH Ni STRIPE
3	CONTACT (A)	PHOSPHOR BRONZE	SEE TABLE 1
2	ACTUATOR	LCP	UL94V-0, BEIGE
1	HOUSING	LCP	UL94V-0, BEIGE

# Connector Assembly

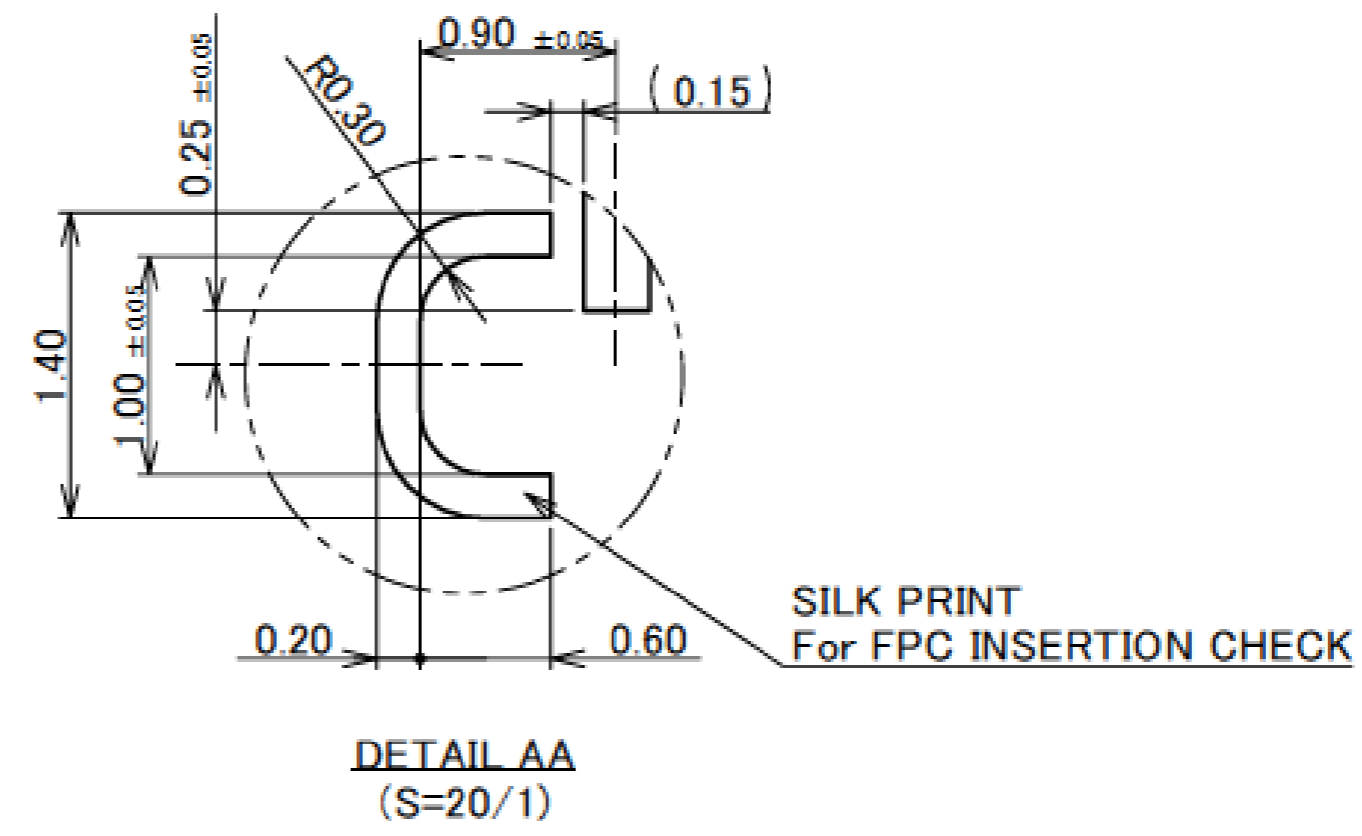
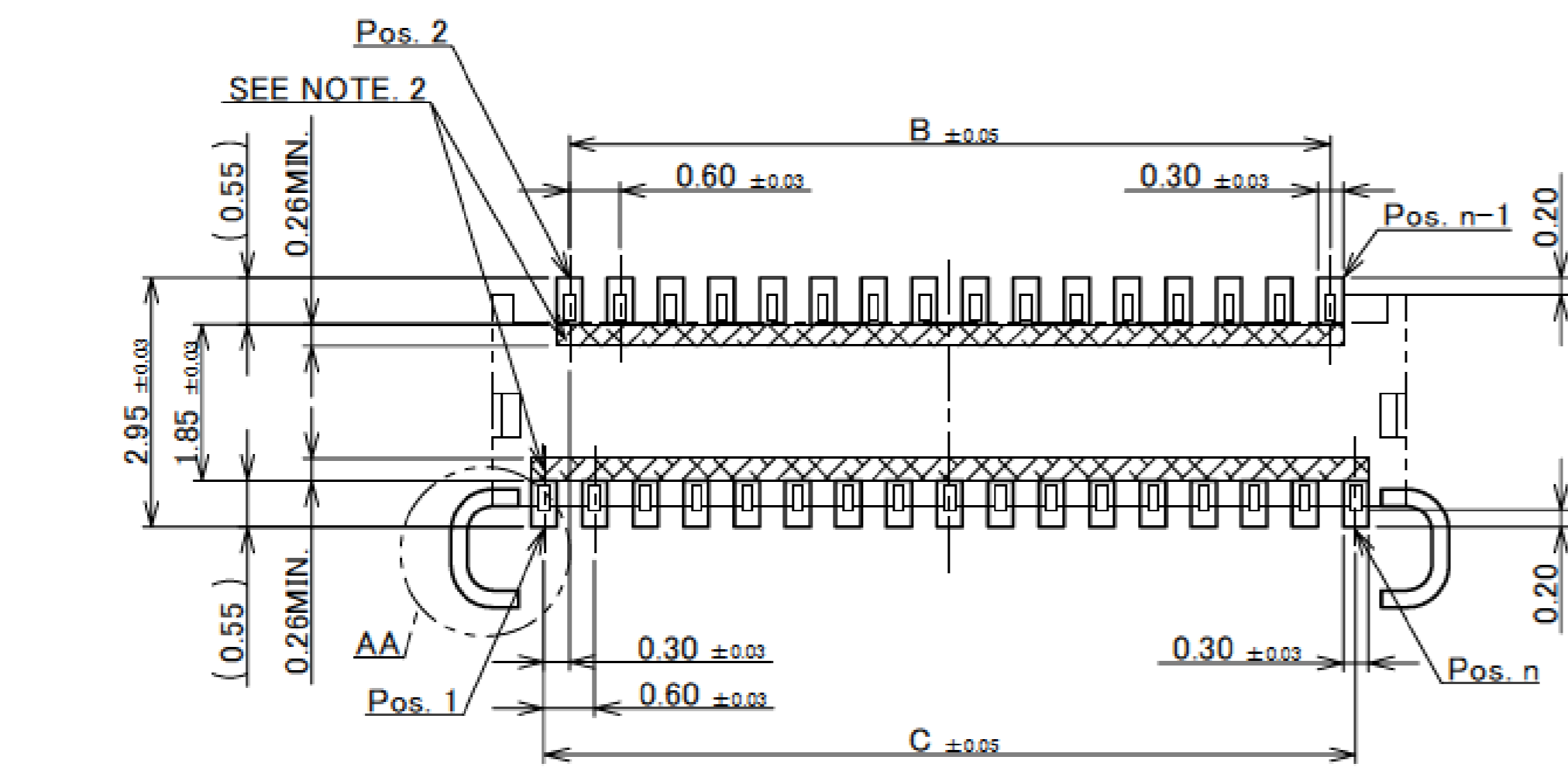
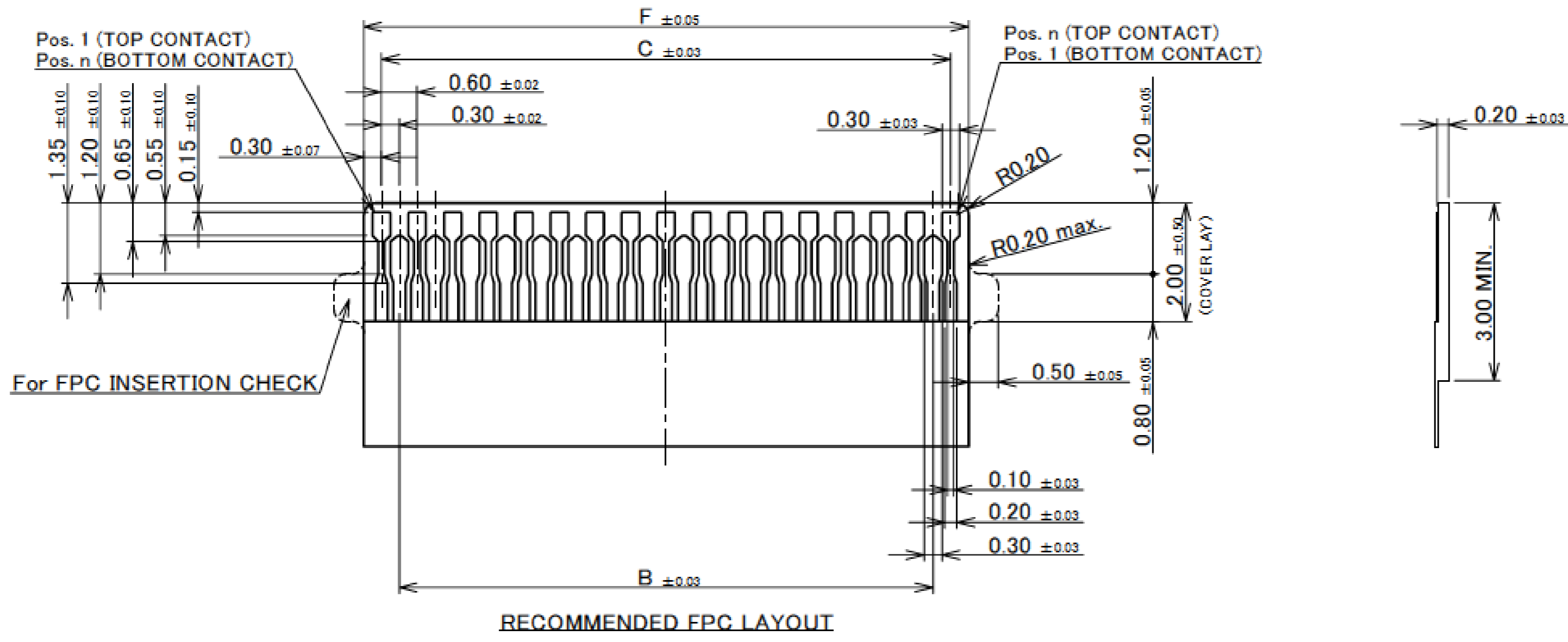

PART NO.	Pos.	B	C	F
20527-013E-0#	13P	3.00	3.60	4.20
20527-015E-0#	15P	3.60	4.20	4.80
20527-017E-0#	17P	4.20	4.80	5.40
20527-019E-0#	19P	4.80	5.40	6.00
20527-021E-0#	21P	5.40	6.00	6.60
20527-023E-0#	23P	6.00	6.60	7.20
20527-025E-0#	25P	6.60	7.20	7.80
20527-027E-0#	27P	7.20	7.80	8.40
20527-029E-0#	29P	7.80	8.40	9.00
20527-031E-0#	31P	8.40	9.00	9.60
20527-033E-0#	33P	9.00	9.60	10.20
20527-035E-0#	35P	9.60	10.20	10.80
20527-037E-0#	37P	10.20	10.80	11.40
20527-039E-0#	39P	10.80	11.40	12.00
20527-041E-0#	41P	11.40	12.00	12.60

NOTES.  
2. SOLDER RESIST SHALL BE APPLIED TO PREVENT SHORT CIRCUITS WHEN PLACING SIGNAL LINES ON GROUND AREA.

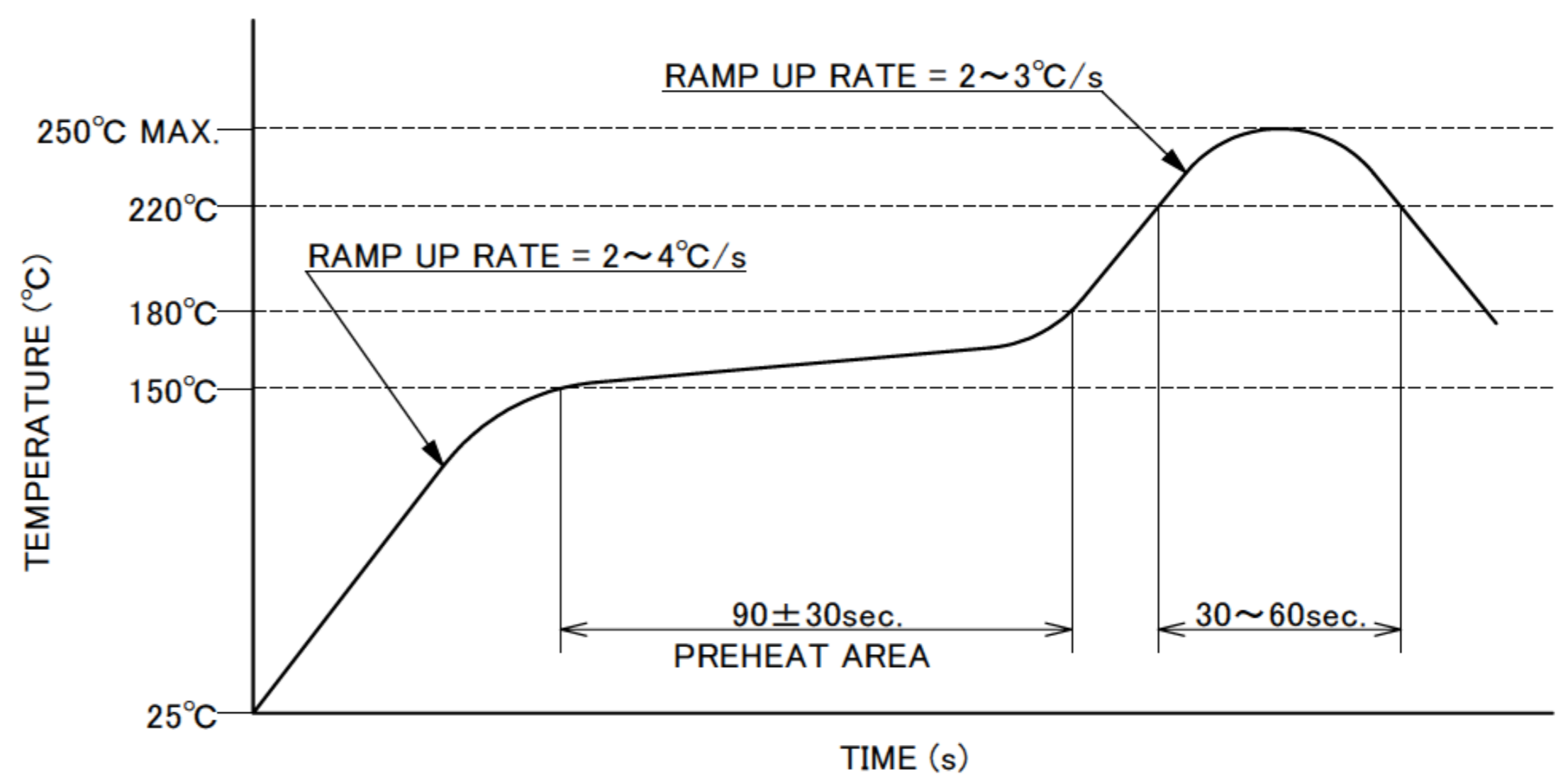
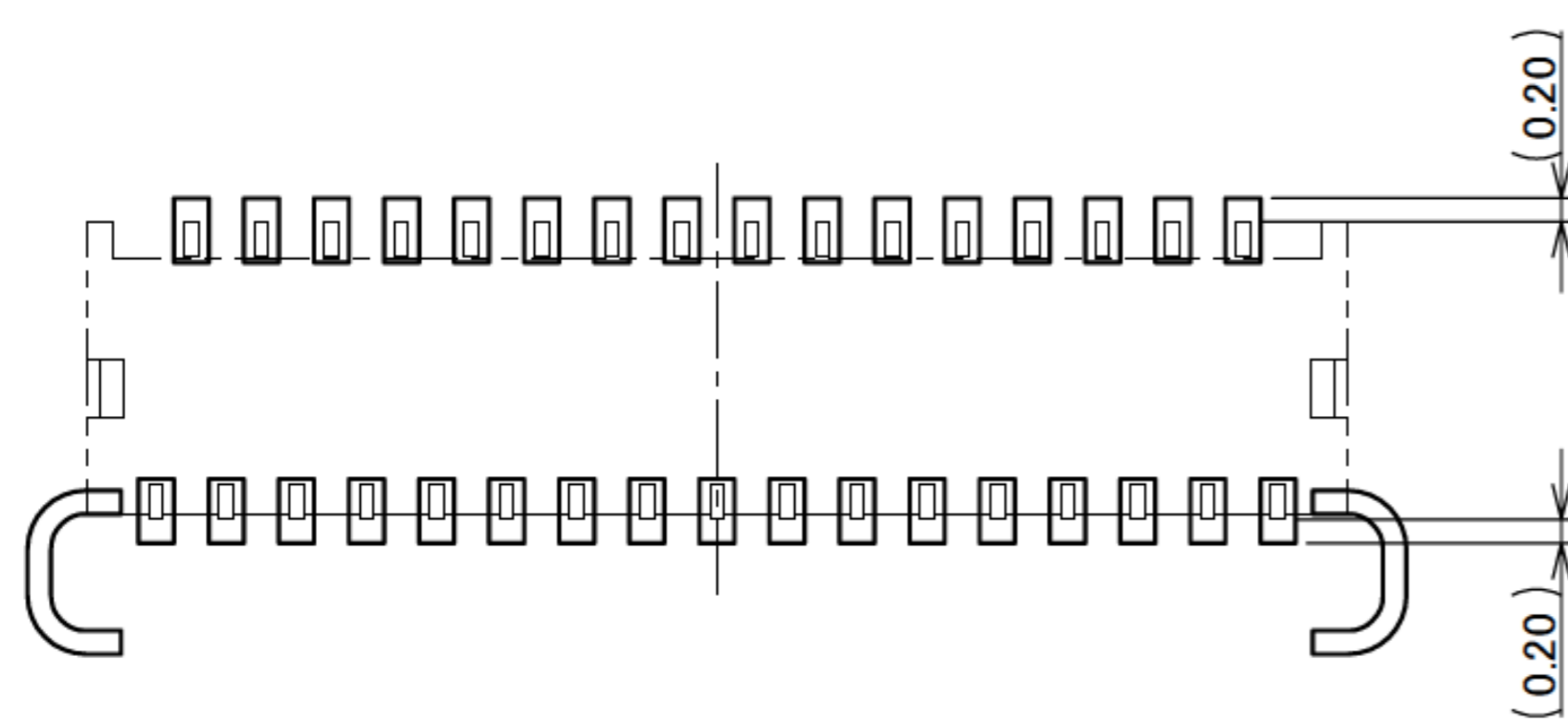

REFLOW TEMPERATURE PROFILE  
SENJU METAL INDUSTRY CO., LTD. : M705-SHF(Sn96.5 Ag3.0 Cu0.5)

Rev.20

# Connector Assembly

ITEMS	SPECIFICATION
RATING VOLTAGE	50V AC (PER CONTACT)
RATING AMPERAGE	0.3A DC (PER CONTACT)
OPERATING TEMPERATURE	233~358K (-40°C~+85°C)
OPERATING HUMIDITY	20~80%RH (NON-CONDENSING)
CONTACT RESISTANCE	INITIAL : 60mohm MAX. / AFTER TEST : $\triangleleft$ 40mohm MAX.
INSULATION RESISTANCE	100Mohm MIN.
DIELECTRIC WITHSTANDING VOLTAGE	AC250V 1min
DURABILITY	20 CYCLES
ACTUATOR LOCKING FORCE (INITIAL / 20 CYCLES)	INITIAL / 20 CYCLES 0.31N (31gf) $\times$ n MAX.
ACTUATOR UNLOCKING FORCE (INITIAL / 20 CYCLES)	INITIAL / 20 CYCLES 0.02N (2gf) $\times$ n MIN.
FPC RETENTION FORCE (INITIAL / AFTER TEST)	INITIAL: 0.13N (13gf) $\times$ n MIN. / AFTER TEST: 0.10N (10gf) $\times$ n MIN.
COPLANARITY	0.10 MAX.
PRODUCT SPECIFICATION	PRS-1512
TEST REPORT	TR-10011
PACKING STANDARD	300-826
INSTRUCTION MANUAL	HIM-12007
APPEARANCE CRITERIA No.	QLS-A***

※ "n" IS THE NUMBER OF PIN

Rev.20

Recommended P/N 20538-0\*\*E-01

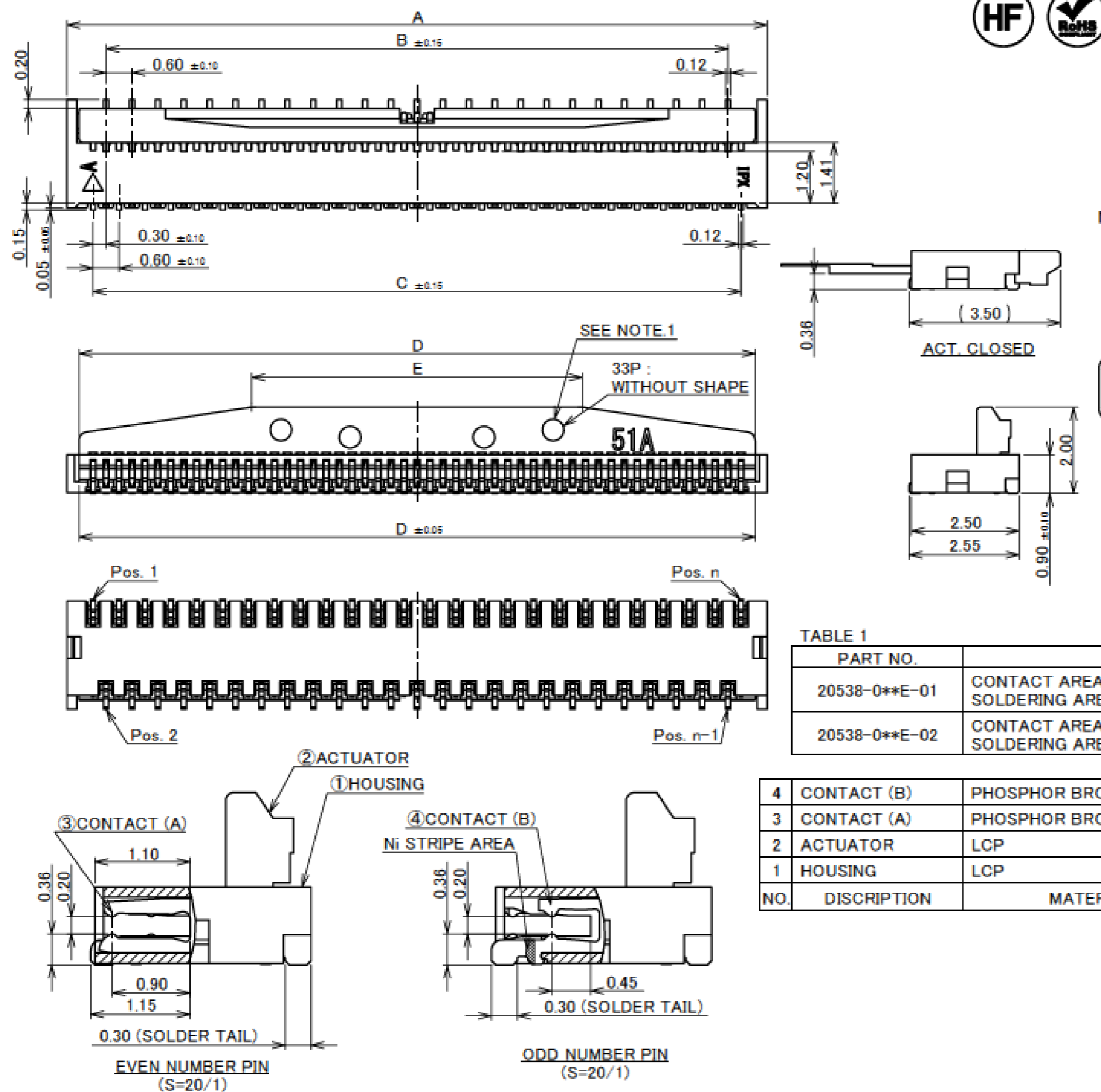

PART NO.	Pos.	A	B	C	D	E
20538-033E-0#	33P	10.80	9.00	9.60	10.25	6.25
20538-035E-0#	35P	11.40	9.60	10.20	10.85	6.85
20538-039E-0#	39P	12.60	10.80	11.40	12.05	8.05
20538-041E-0#	41P	13.20	11.40	12.00	12.65	8.65
20538-045E-0#	45P	14.40	12.60	13.20	13.85	9.85
20538-049E-0#	49P	15.60	13.80	14.40	15.05	11.05
20538-051E-0#	51P	16.20	14.40	15.00	15.65	11.65
20538-055E-0#	55P	17.40	15.60	16.20	16.85	12.85
20538-057E-0#	57P	18.00	16.20	16.80	17.45	13.45
20538-061E-0#	61P	19.20	17.40	18.00	18.65	14.65
20538-065E-0#	65P	20.40	18.60	19.20	19.85	15.85

NOTES.  
 1. THIS DENT SHAPE IS PURPOSED FOR GOOD INJECTION QUALITY. THIS DENT SHAPE WILL NOT AFFECT CONNECTR FUNCTION. DENT SHAPE SHOWN ON DRAWING IS JUST FOR REFERENCE. DENT SHAPE AND QUANTITY MIGHT CHABGE FROM DIFFERENT PIN COUNT AND DIFFERENT TOOLING.  
 2. CONTACT POINT : TOP AND BOTTOM CONTACT

CAUTION VISIT OUR WEBSITE FOR LATEST VERSIONS OF INSTRUCTION MANUAL NO. HIM-12007 TO HANDLE THE PRODUCT PROPERLY AND SAFELY.

TABLE 1

PART NO.	FINISH
20538-0**E-01	CONTACT AREA : Au 0.10 $\mu$ m MIN. OVER Ni 1.00 $\mu$ m MIN. SOLDERING AREA : Au 0.03 $\mu$ m MIN. OVER Ni 1.00 $\mu$ m MIN.
20538-0**E-02	CONTACT AREA : Au 0.254 $\mu$ m MIN. OVER Ni 1.00 $\mu$ m MIN. SOLDERING AREA : Au 0.03 $\mu$ m MIN. OVER Ni 1.00 $\mu$ m MIN.

NO.	DISCRIPTION	MATERIAL	FINISH, REMARKS
4	CONTACT (B)	PHOSPHOR BRONZE	SEE TABLE 1, WITH Ni STRIPE
3	CONTACT (A)	PHOSPHOR BRONZE	SEE TABLE 1
2	ACTUATOR	LCP	UL94V-0, BEIGE
1	HOUSING	LCP	UL94V-0, BEIGE

Rev.17

# Connector Assembly

PART NO.	Pos.	B	C	F
20538-033E-0#	33P	9.00	9.60	10.20
20538-035E-0#	35P	9.60	10.20	10.80
20538-039E-0#	39P	10.80	11.40	12.00
20538-041E-0#	41P	11.40	12.00	12.60
20538-045E-0#	45P	12.60	13.20	13.80
20538-049E-0#	49P	13.80	14.40	15.00
20538-051E-0#	51P	14.40	15.00	15.60
20538-055E-0#	55P	15.60	16.20	16.80
20538-057E-0#	57P	16.20	16.80	17.40
20538-061E-0#	61P	17.40	18.00	18.60
20538-065E-0#	65P	18.60	19.20	19.80

NOTES.  
3. SOLDER RESIST SHALL BE APPLIED TO PREVENT SHORT CIRCUITS WHEN PLACING SIGNAL LINES ON GROUND AREA.

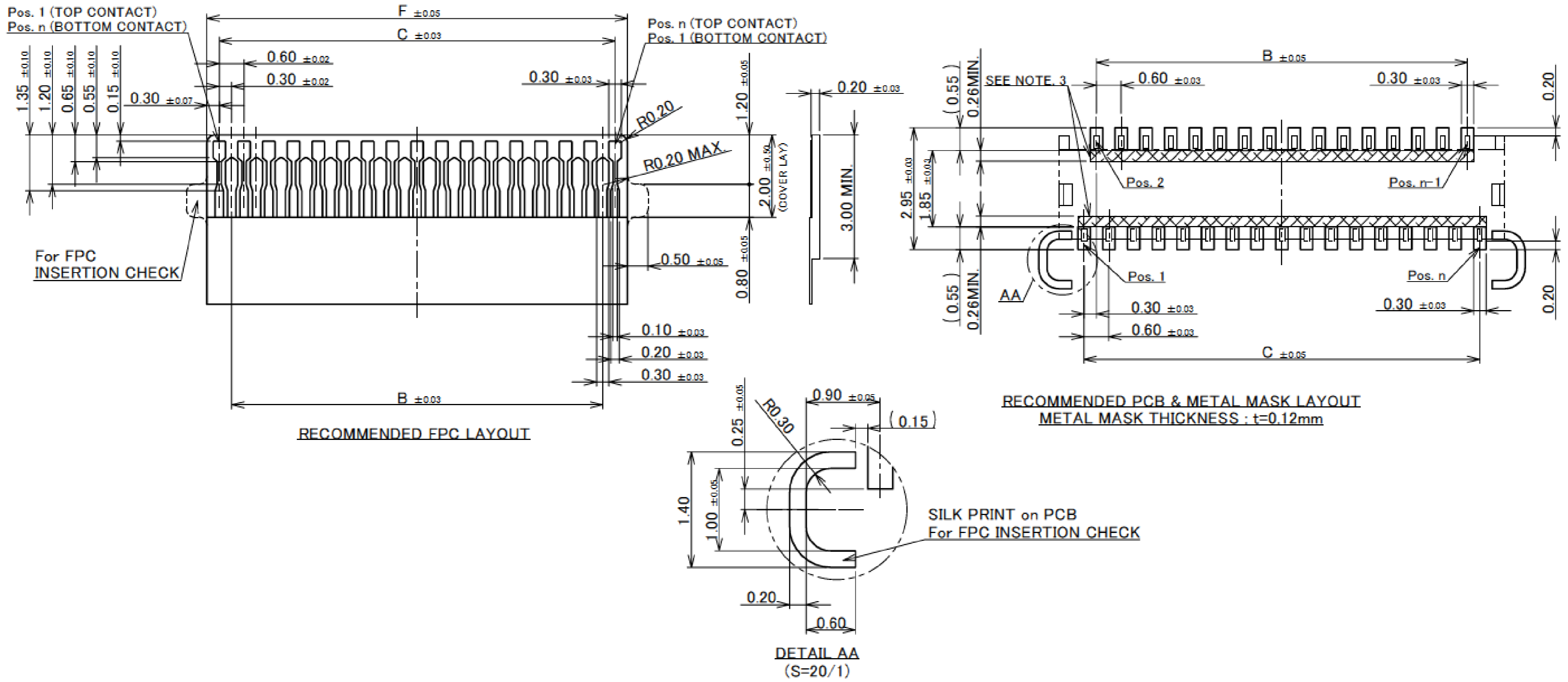

Rev.17

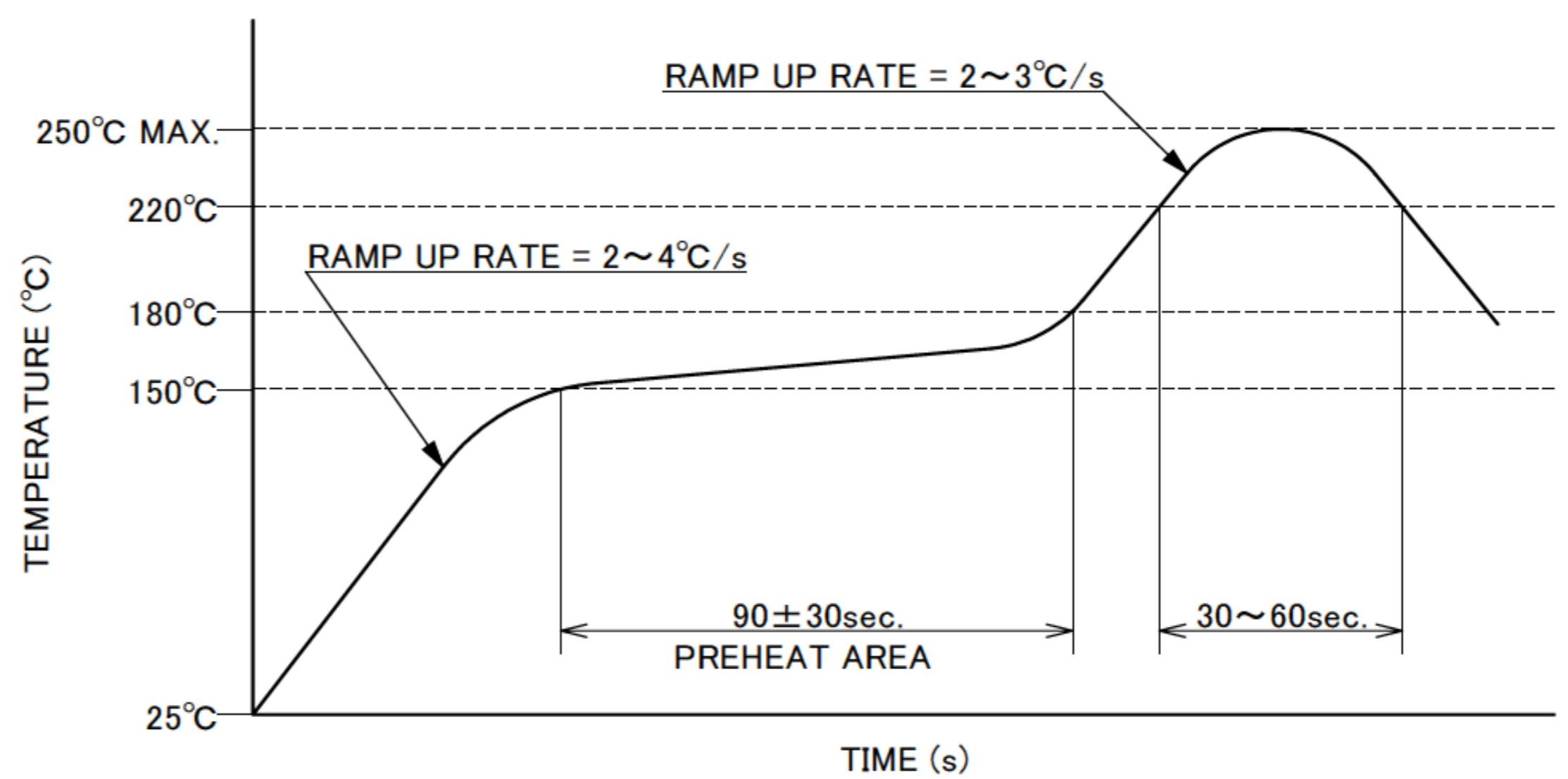
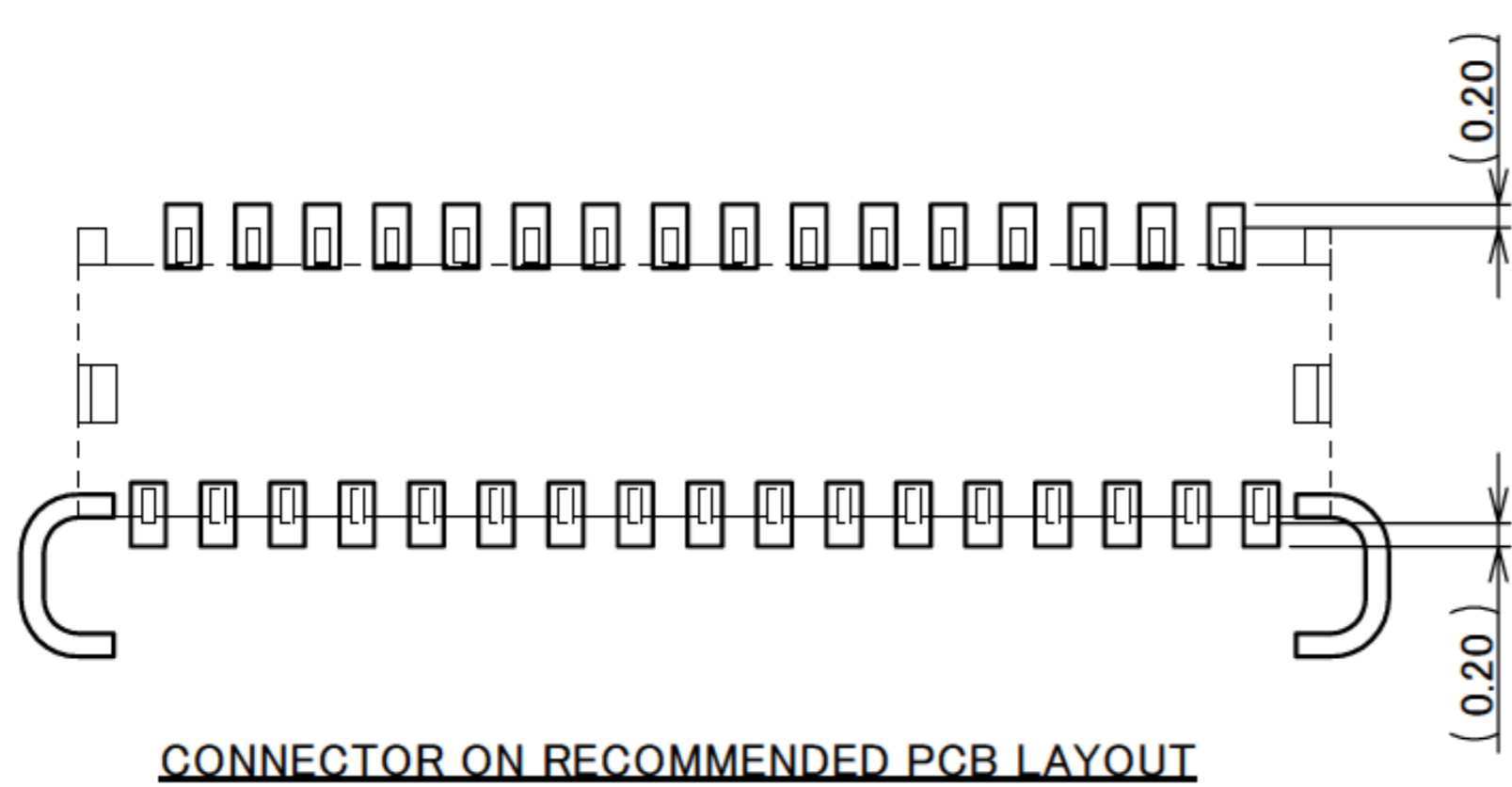

REFLOW TEMPERATURE PROFILE  
SENJU METAL INDUSTRY CO., LTD. : M705-SHF(Sn96.5 Ag3.0 Cu0.5)

Rev.17



# Connector Assembly

ITEMS	SPECIFICATION
RATING VOLTAGE	50V AC (PER CONTACT)
RATING AMPERAGE	0.3A DC (PER CONTACT)
OPERATING TEMPERATURE	233~358K (-40°C~+85°C)
OPERATING HUMIDITY	20~80%RH (NON-CONDENSING)
CONTACT RESISTANCE	INITIAL : 60mohm MAX. / AFTER TEST : $\triangle$ 40mohm MAX.
INSULATION RESISTANCE	100Mohm MIN.
DIELECTRIC WITHSTANDING VOLTAGE	AC250V 1min
DURABILITY	20 CYCLES
ACTUATOR LOCKING FORCE (INITIAL / 20 CYCLES)	INITIAL / 20 CYCLES 0.21N (21gf) $\times$ n MAX.
ACTUATOR UNLOCKING FORCE (INITIAL / 20 CYCLES)	INITIAL / 20 CYCLES 0.014N (1.4gf) $\times$ n MIN.
FPC RETENTION FORCE (INITIAL / AFTER TEST)	INITIAL: 0.13N (13gf) $\times$ n MIN. / AFTER TEST: 0.10N (10gf) $\times$ n MIN.
COPLANARITY	0.10 MAX.
PRODUCT SPECIFICATION	PRS-1579
TEST REPORT	TR-12040
PACKING STANDARD	300-920
INSTRUCTION MANUAL	HIM-12007
APPEARANCE CRITERIA No.	QLS-A***

※ "n" IS THE NUMBER OF PIN

Rev.17



# Custom Connectors Available

 RF Connector

MHF® series



 CABLINE® series  
Micro-coaxial/Twinax/  
Discrete Wire Connector



 Optical Module

LIGHTPASS® series



NOVASTACK® series

 Board-to-Board Connector

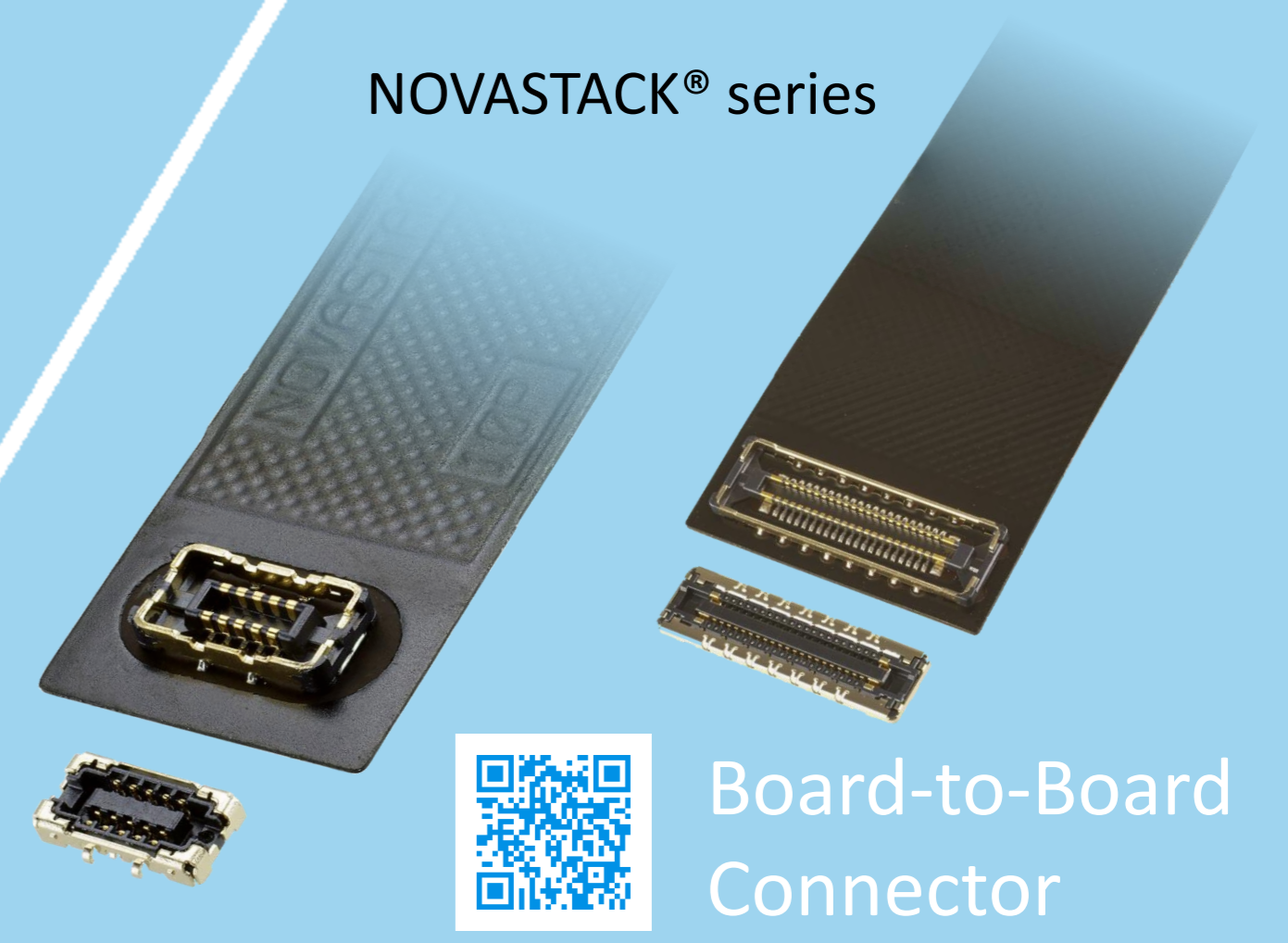

 Power Connector/  
Terminal

AP series

ISH® series



MINIFLEX® series

EVAFLEX® series

 FPC FFC Connector



Inquiry



MINIDOCK® series

 I/O Connector

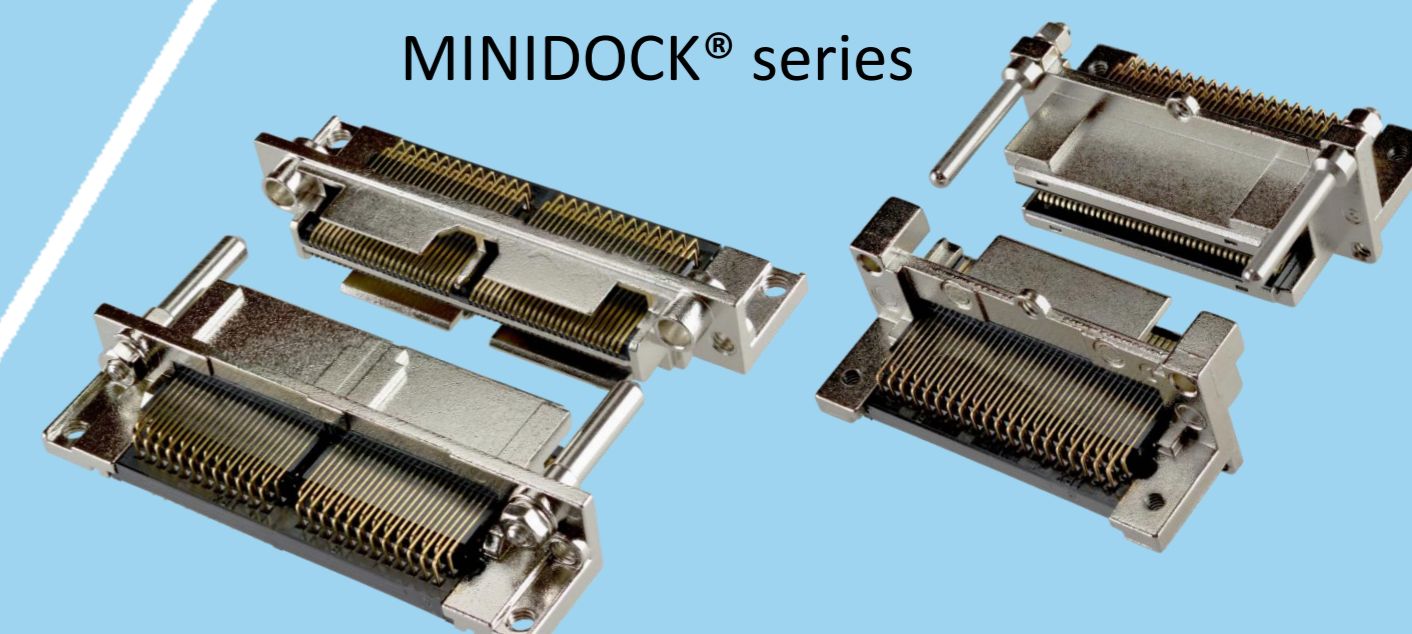

I-PEX, MHF, CABLINE, LIGHTPASS, NOVASTACK, ISH, IARPB, MINIFLEX, EVAFLEX, MINIDOCKS and ZenShield are registered trademarks of I-PEX Inc. Please note that the contents in the catalog might be changed without prior notification. I-PEX Inc. assumes no responsibility for any inaccuracies or obligation to update information on these documents. Please be sure to read and understand the latest "Precautions for Use" and "Instruction Manual" before you use our products. We shall not be responsible for any defects, damages or troubles in case you use our products without following the precautions for use. Please feel free to contact our sales representatives when you use our products for any applications that require very high reliability and safety, or that relate to human life (ex. nuclear power control, aerospace, transportation, medical equipment, safety equipment etc.).

Contact your sales representative or more detailed information.

[www.i-pex.com](http://www.i-pex.com)



# I-PEX

© I-PEX Inc. 2024  
All rights reserved