

# MHF<sup>®</sup> 5

Low-profile (mated height = 1.0 mm max.), supports to 12 GHz

**Product Specifications:**

Mated Height (mm max.)	1.0	
Rece. SMT Size (mm)	2.0 x 2.0	
Applicable Frequency	DC ~ 12 GHz	
Characteristic Impedance	50 ohm	
VSWR (L=100 mm)	DC~3 GHz	(1)(2)(3) 1.3 max.
	3~6 GHz	(1)(2)(3) 1.5 max.
	6~9 GHz	(1)(2)(3) 1.6 max.
	9~12 GHz	(1) 1.6 max. (2) 1.8 max. (3) 1.7 max.

\* Cable size O.D. (1) 0.48 mm, (2) 0.64 mm (3) 0.81 mm

**Applicable Cable Size:**

O.D. 0.48 mm / AWG 38
O.D. 0.64 mm / AWG 36
O.D. 0.81 mm / AWG 36

**Applicable Standards (Reference Only):**

5G sub-6, Wi-Fi 6E, LTE/LTE-Advanced, LPWA, Bluetooth, GPS

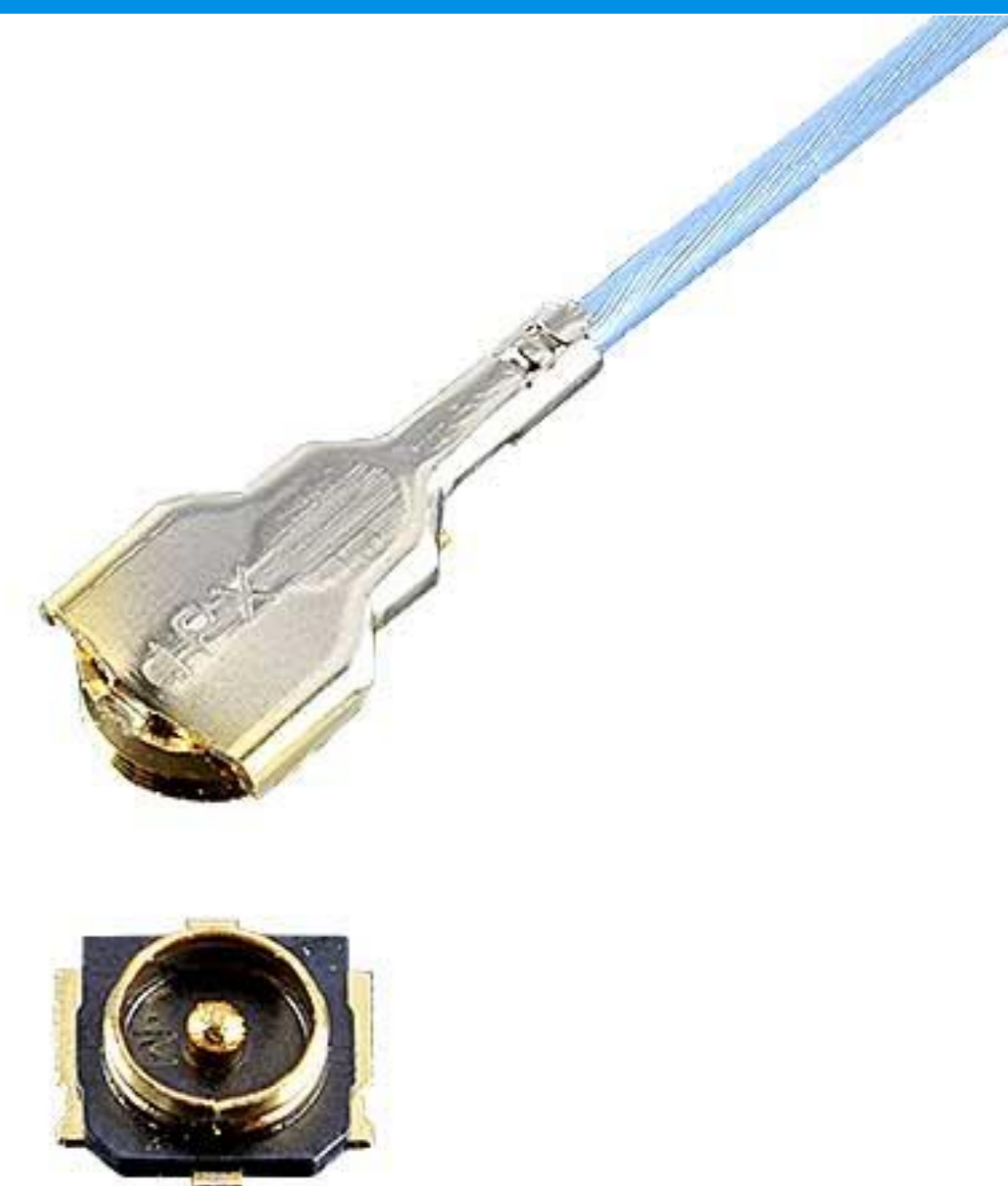

## ▶ Small form factor with big performance through 12 GHz

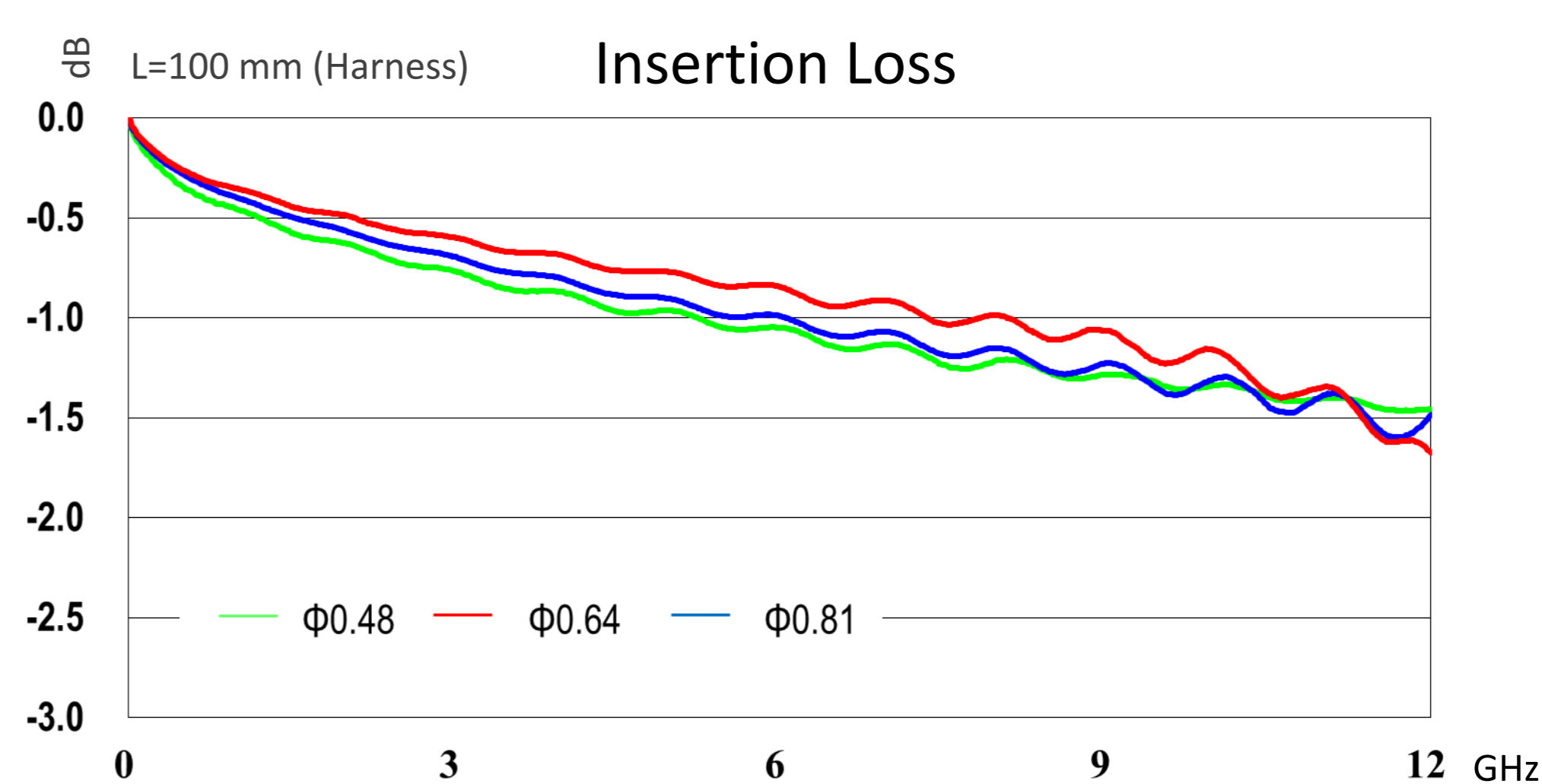
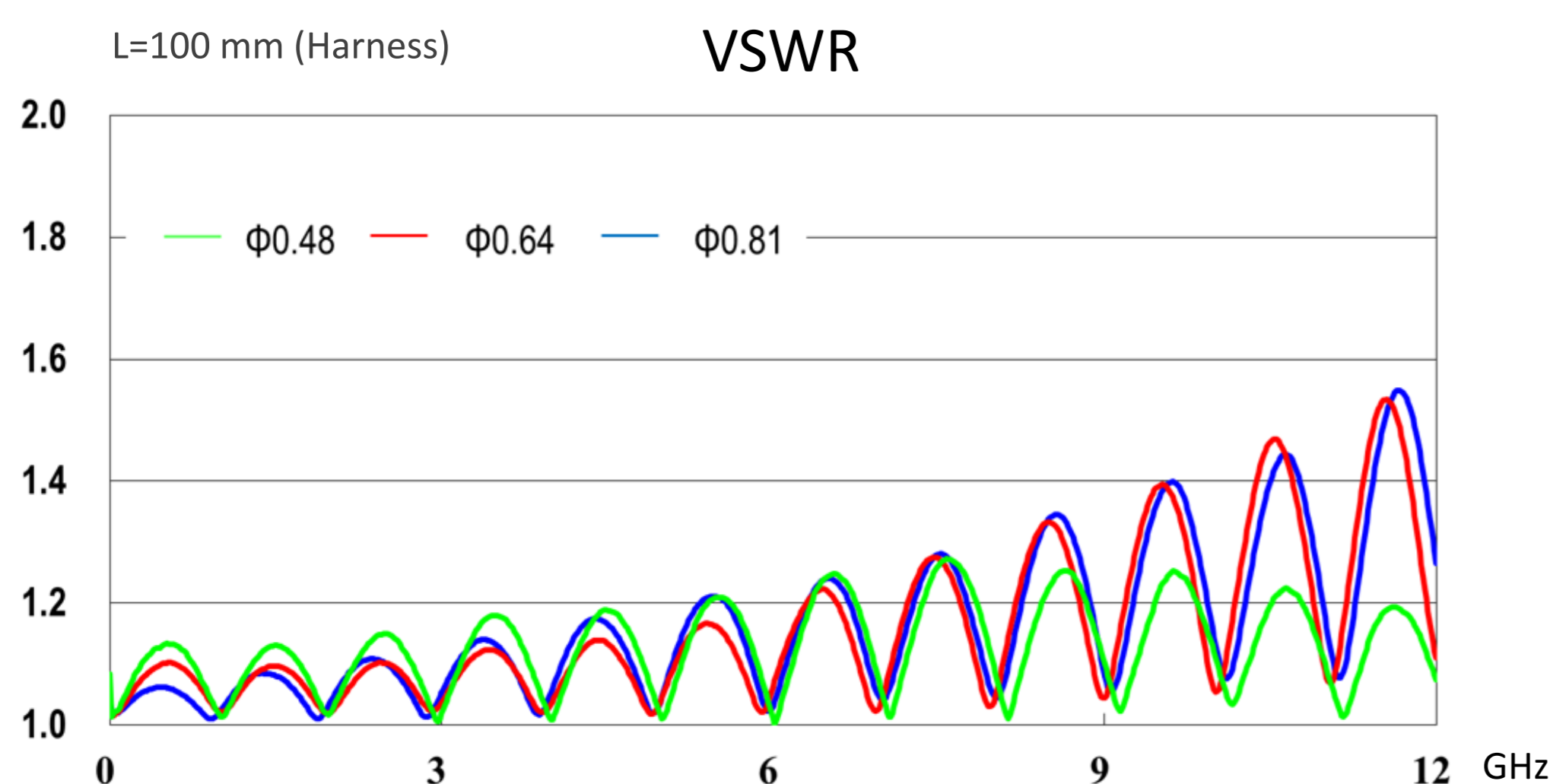

## ▶ Lowest profile connector of MHF<sup>®</sup> series

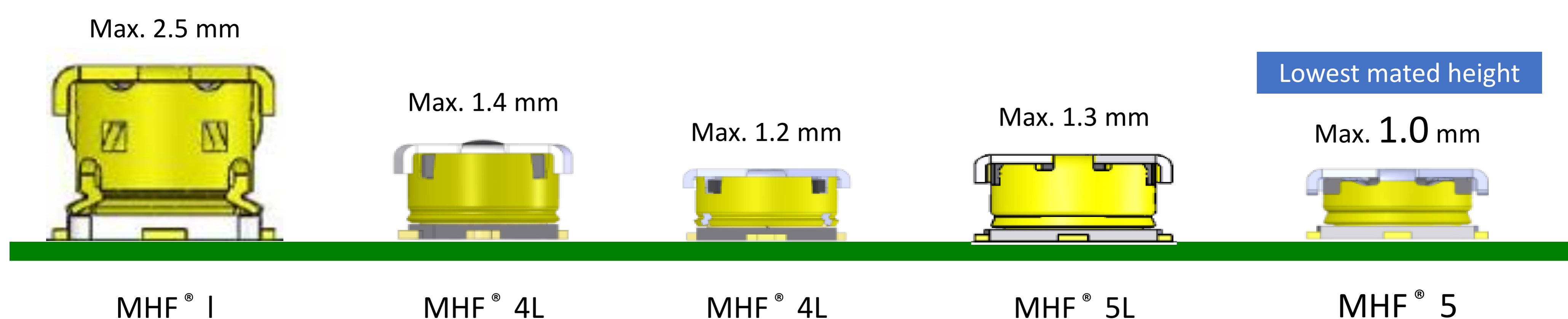

## ▶ MHF<sup>®</sup> 5 Plug available cable O.D. (AWG) : 0.81 mm (36), 0.64 mm (36), 0.48 mm (38)

Product name	MHF <sup>®</sup> 5	MHF <sup>®</sup> 5L
Mating Height	1.0 mm max.	1.3 mm max.
Coax O.D. (Center Conductor AWG)	1.13 mm (AWG#32)	●
	0.81 mm (AWG#33)	●
	0.81 mm (AWG#36)	●
	0.64 mm (AWG#36)	●
	0.48 mm (AWG#38)	●
Receptacle	MHF <sup>®</sup> 5 receptacle	

# Component Parts Details

## MHF<sup>®</sup> 5 plug Au (0.81,0.64)

Recommended P/N		20669-001R-81
PART NO.	APPLICABLE CABLE	OUTER CONDUCTOR
20669-001R-81	AWG#36 (0.64 O.D.)	SPIRAL SHIELD
	AWG#36 (0.81 O.D.)	SINGLE BRAIDED SHIELD

OFFERED AS HARNESS ONLY.

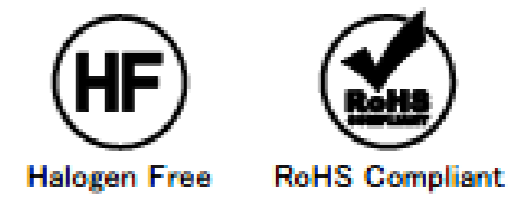
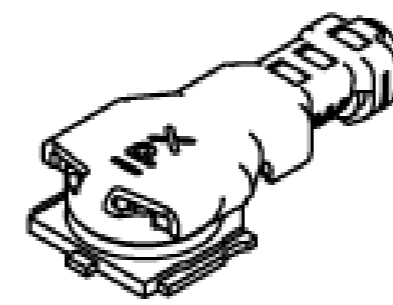
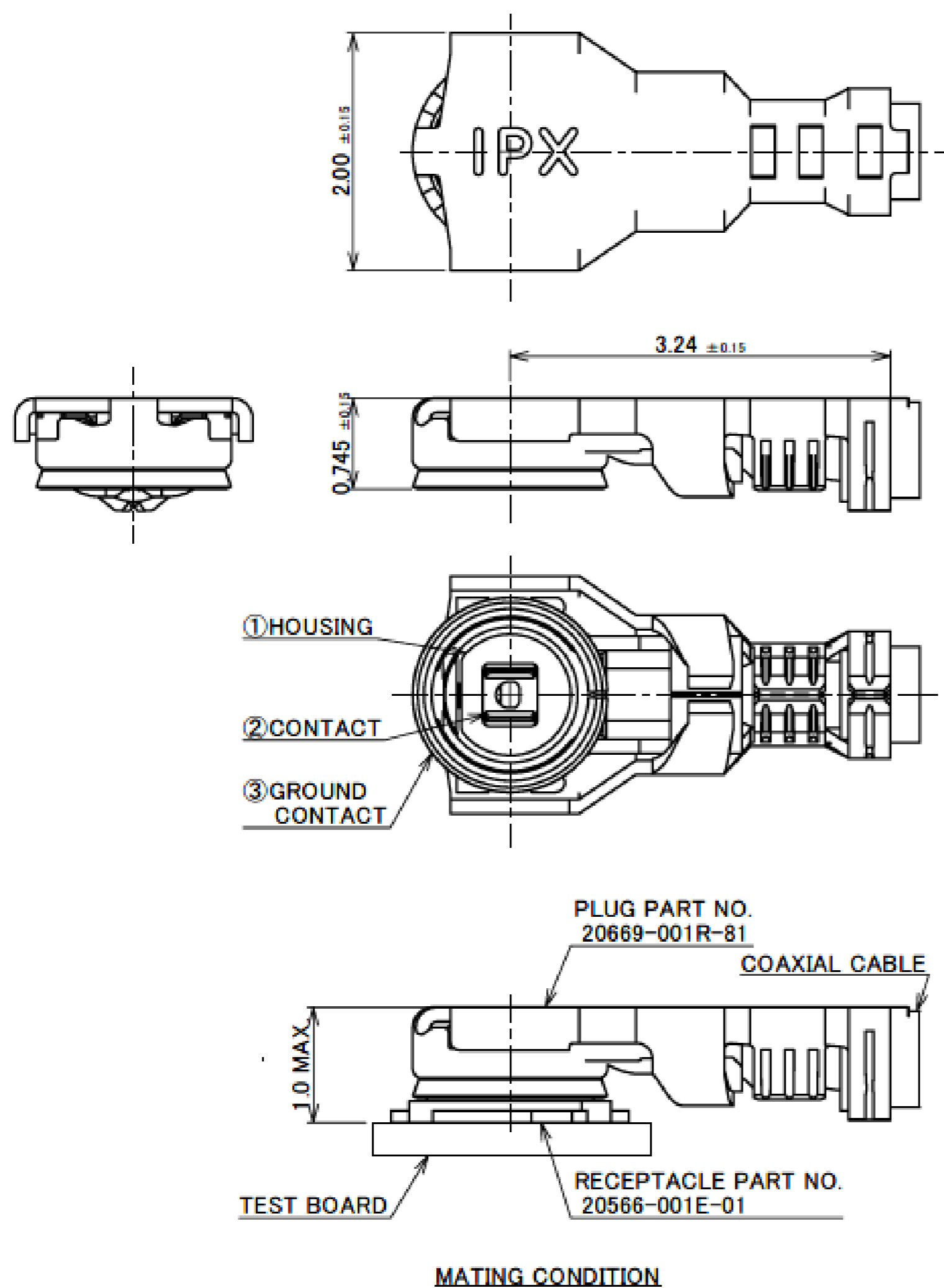

### NOTES

- APPLICABLE CONNECTOR  
20566-001E-01
- PERMISSIBLE LOAD OF CABLE AT MATING
- MATING AND UNMATING INSTRUCTION
  - MATING  
MATE THE CONNECTOR VERTICALLY AS MUCH AS POSSIBLE, ADJUSTING THE MATING AXIS OF PLUG AND RECEPTACLE. DO NOT SLANT MATE.
  - UNMATING  
USE THE PULLING TOOL AS THE FOLLOWING DRAWING, AND PULL PLUG TO VERTICAL DIRECTION AS DIRECTLY AS POSSIBLE.
    - IN CASE OF UNMATING BY PULLING TOOL (PART NO. 90612-0001)  
USE THE PULLING TOOL AS THE FOLLOWING DRAWING, AND PULL PLUG TO VERTICAL DIRECTION AS DIRECTLY AS POSSIBLE.
    - IN CASE OF UNMATING DIRECTLY BY HAND.  
CATCH THE CATCHING AREA OF PLUG, AND PULL PLUG TO VERTICAL DIRECTION AS DIRECTLY AS POSSIBLE.
- PRECAUTIONS FOR CABLE POSITION  
THE PLUG SHALL NOT BE PLACED WITHIN 50 DEGREES ANGLE FROM CENTER OF THE SIGNAL CONTACT. TILT THE PLUG AT LEAST 50 DEGREES FROM THE CENTER OF A SIGNAL CONTACT.

### NOTE 2.

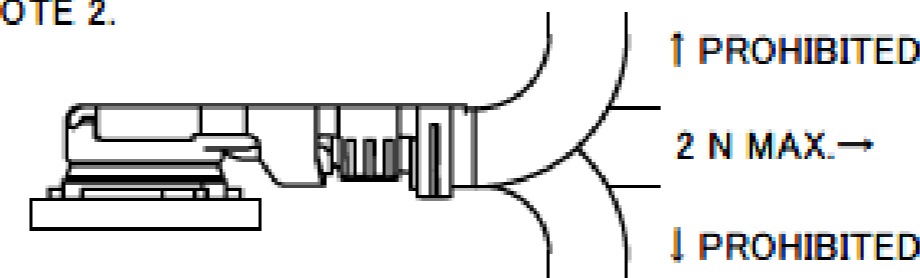

### NOTE 3-1.

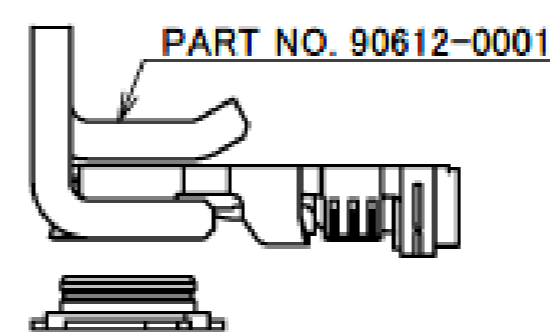

### NOTE 3-2-1.

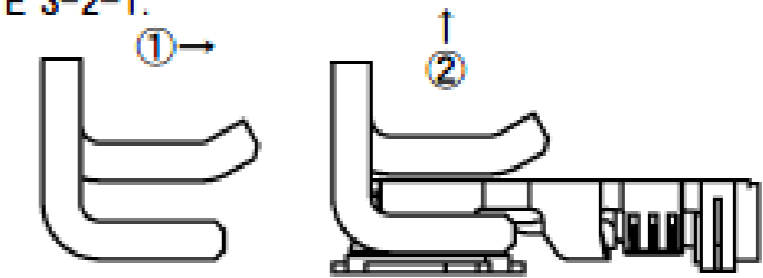

### NOTE 3-2-2.

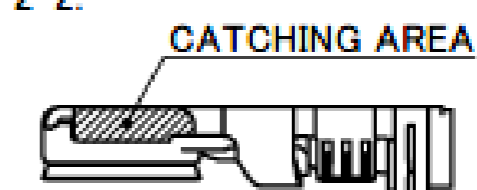

NO.	DESCRIPTION	MATERIAL	FINISH , REMARKS
3	GROUND CONTACT	PHOSPHOR BRONZE	ALL OVER Ni 1.00 μm MIN. CONTACT PART Au 0.05 μm MIN.
2	CONTACT	PHOSPHOR BRONZE	ALL OVER Ni 1.00 μm MIN. CONTACT PART Au 0.05 μm MIN.
1	HOUSING	LCP	UL94V-0, BLACK

# MHF® 5 plug Au (0.81,0.64)

ITEMS	SPECIFICATION	
	AWG#36(0.81 O.D.)	AWG#36(0.64 O.D.)
APPLICABLE CABLE	AWG#36(0.81 O.D.)	AWG#36(0.64 O.D.)
RECOMMENDED APPLICABLE CONNECTOR PART No.	20566-001E-01	
RATING VOLTAGE	60 V AC (R.M.S)	
RATING FREQUENCY	DC~12 GHz	
OPERATING TEMPERATURE	233~363 K (-40°C~+90°C)	
VSWR (MATED WITH SMA ADAPTER PART No. 90543-0001)	1.30 MAX. AT 0.1~3 GHz, 1.50 MAX. AT 3~6 GHz, 1.60 MAX. AT 6~9 GHz, 1.70 MAX. AT 9~12 GHz	1.30 MAX. AT 0.1~3 GHz, 1.50 MAX. AT 3~6 GHz, 1.60 MAX. AT 6~9 GHz, 1.80 MAX. AT 9~12 GHz
MAIN CONTACT RESISTANCE	INITIAL: 20 mohm MAX. / AFTER TEST: $\Delta$ R 20 mohm MAX.	
GROUND CONTACT RESISTANCE	INITIAL: 20 mohm MAX. / AFTER TEST: $\Delta$ R 20 mohm MAX.	
INSULATION RESISTANCE	INITIAL: 500 Mohm MIN. / AFTER TEST: 100 Mohm MIN.	
DIELECTRIC WITHSTANDING VOLTAGE	200 V AC, 1 MINUTE	
DURABILITY	30 CYCLES	
UNMATING FORCE (INITIAL / AFTER TEST)	INITIAL: 4 N MIN. / AFTER TEST: 2 N MIN.	
CRIMP STRENGTH	7 N MIN.	
PRODUCT SPECIFICATION	PRS-2532	PRS-2782
TEST REPORT	TR-18089	TR-22018
INSTRUCTION MANUAL	HIM-16014	
APPEARANCE CRITERIA No.	QLS-A***	

Rev.4

# MHF® 5 plug Ni top (0.81,0.64)

Recommended P/N		
20711-001R-81		
PART NO.	APPLICABLE CABLE	OUTER CONDUCTOR
20711-001R-81	AWG#36 (0.64 O.D.)	SPIRAL SHIELD
	AWG#36 (0.81 O.D.)	SINGLE BRAIDED SHIELD

OFFERED AS HARNESS ONLY.

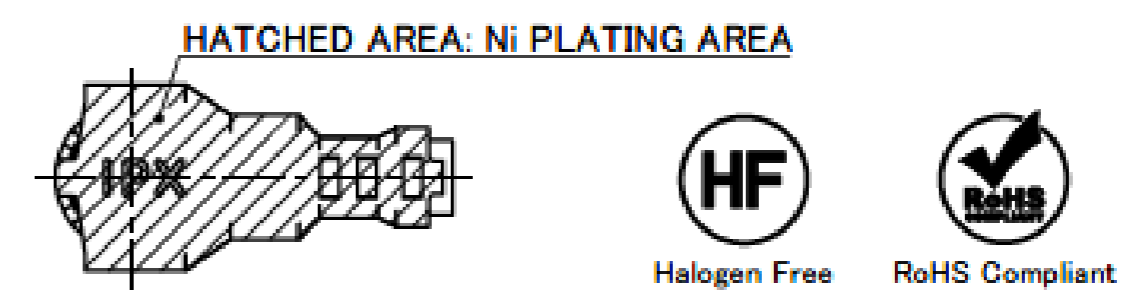
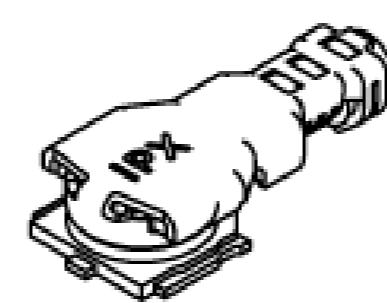
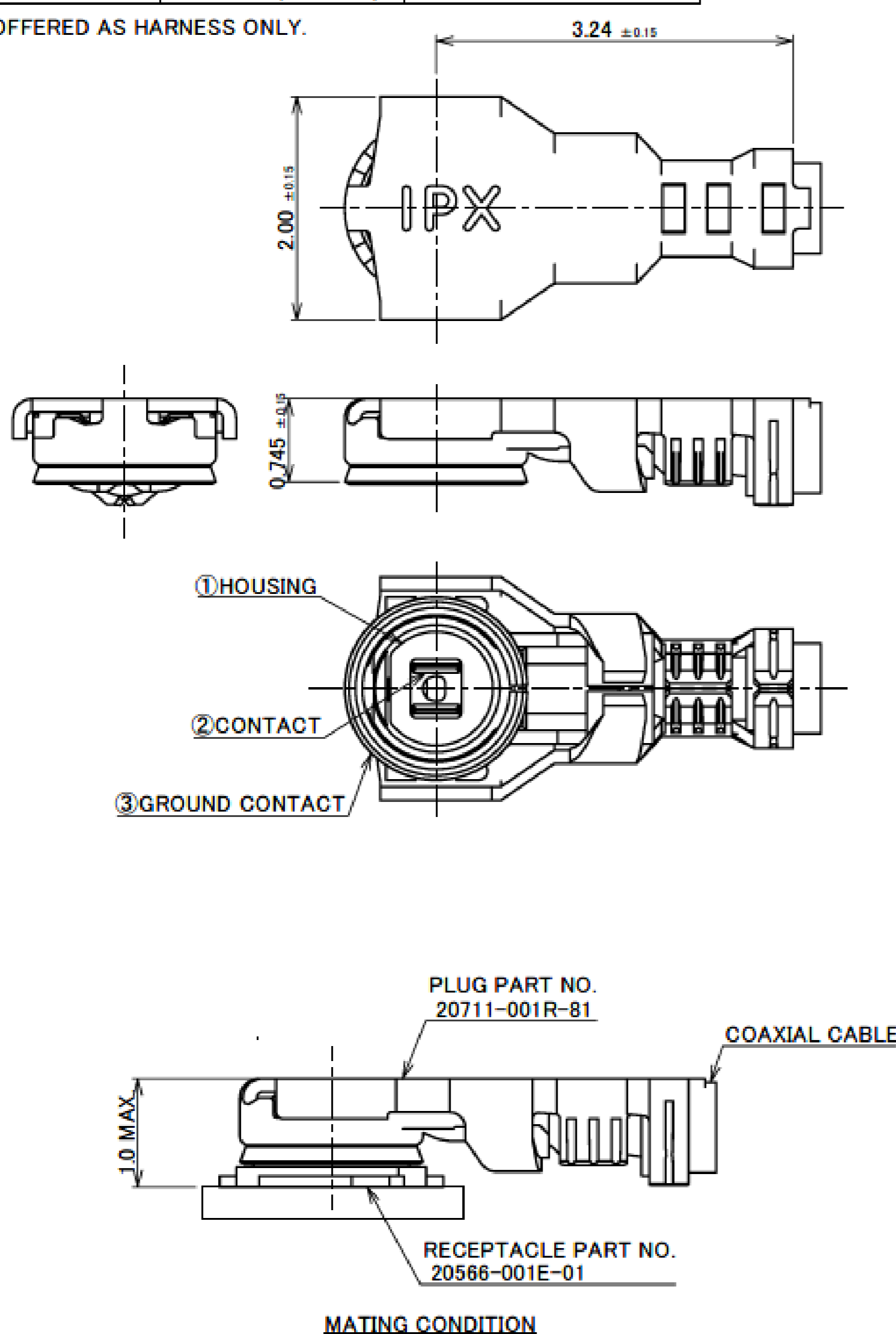

**NOTES.**

1. APPLICABLE CONNECTOR: 20566-001E-01
2. PERMISSIBLE LOAD OF CABLE AT MATING
3. MATING AND UNMATING INSTRUCTION
  - 3-1. MATING  
MATE THE CONNECTOR VERTICALLY AS MUCH AS POSSIBLE, ADJUSTING THE MATING AXIS OF PLUG AND RECEPTACLE. DO NOT SLANT MATE.
  - 3-2. UNMATING
    - 3-2-1. IN CASE OF UNMATING BY PULLING TOOL (PART NO. 90612-0001) USE THE PULLING TOOL AS THE FOLLOWING DRAWING, AND PULL PLUG TO VERTICAL DIRECTION AS DIRECTLY AS POSSIBLE.
    - 3-2-2. IN CASE OF UNMATING DIRECTLY BY HAND CATCH THE CATCHING AREA OF PLUG, AND PULL PLUG TO VERTICAL DIRECTION AS DIRECTLY AS POSSIBLE.

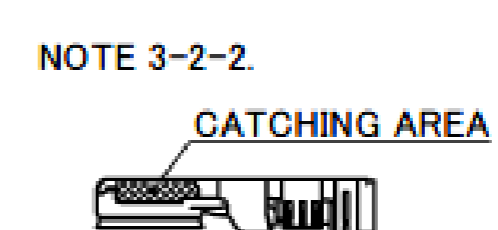
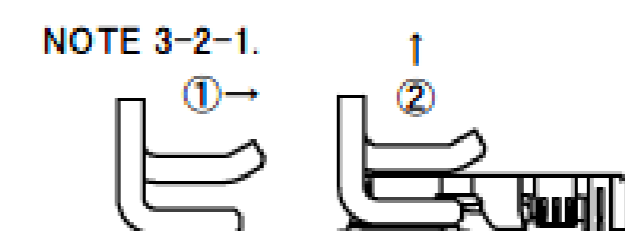
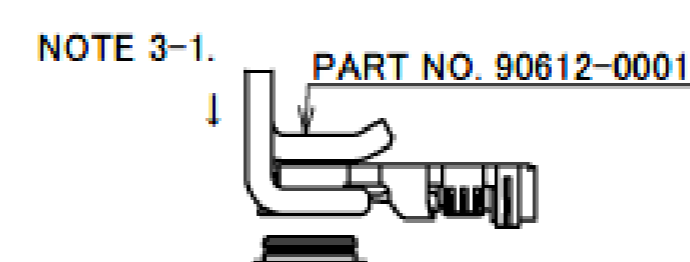
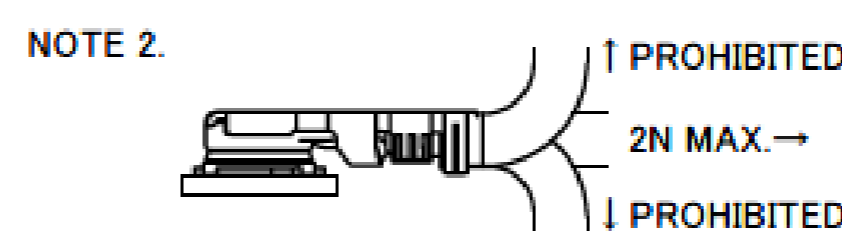

NO.	DESCRIPTION	MATERIAL	FINISH, REMARKS
3	GROUND CONTACT	PHOSPHOR BRONZE	ALL OVER Ni 1.00 $\mu$ m MIN. CONTACT PART Au 0.02 $\mu$ m MIN. (Ni PLATING AREA) Ni ONLY
2	CONTACT	PHOSPHOR BRONZE	ALL OVER Ni 1.00 $\mu$ m MIN. CONTACT PART Au 0.03 $\mu$ m MIN.
1	HOUSING	LCP	UL94V-0, BLACK

Rev.6



# MHF® 5 plug Ni top (0.81,0.64)

ITEMS	SPECIFICATION	
APPLICABLE CABLE	AWG#36 (0.81 O.D.) *RECOMMENDED	AWG#36 (0.64 O.D.)
RECOMMENDED APPLICABLE CONNECTOR PART No.	20566-001E-01	
RATING VOLTAGE	60 V AC (R.M.S)	
RATING FREQUENCY	DC~12 GHz	
OPERATING TEMPERATURE	233~363 K (-40°C~+90°C)	
VSWR (MATED WITH SMA ADAPTER PART No. 90543-0001)	1.30 MAX. AT 0.1~3 GHz, 1.50 MAX. AT 3~6 GHz, 1.60 MAX. AT 6~9 GHz, 1.70 MAX. AT 9~12 GHz	1.30 MAX. AT 0.1~3 GHz, 1.50 MAX. AT 3~6 GHz, 1.60 MAX. AT 6~9 GHz, 1.80 MAX. AT 9~12 GHz
MAIN CONTACT RESISTANCE	INITIAL: 20 mohm MAX. / AFTER TEST: $\Delta$ R 20 mohm MAX.	
GROUND CONTACT RESISTANCE	INITIAL: 20 mohm MAX. / AFTER TEST: $\Delta$ R 100 mohm MAX.	
INSULATION RESISTANCE	INITIAL: 500 Mohm MIN. / AFTER TEST: 100 Mohm MIN.	
DIELECTRIC WITHSTANDING VOLTAGE	200 V AC, 1 MINUTE	
DURABILITY	30 CYCLES	
UNMATING FORCE (INITIAL / AFTER TEST)	INITIAL: 4 N MIN. / AFTER TEST: 2 N MIN.	
CRIMP STRENGTH	7 N MIN.	
PRODUCT SPECIFICATION	PRS-2108	PRS-2109
TEST REPORT	TR-15062	TR-15063
INSTRUCTION MANUAL	HIM-16013	
APPEARANCE CRITERIA No.	QLS-A***	

Rev.6

# MHF® 5 PLUG Ni top (0.48)

Recommended P/N	20615-002R-48		
PART No.	PLATING	APPLICABLE CABLE	OUTER CONDUCTOR
20615-001R-48	ALL Au	AWG#38 (0.48 O.D.)	SPIRAL SHIELD
20615-002R-48	SELECTIVE Ni		

OFFERED AS HARNESS ONLY.

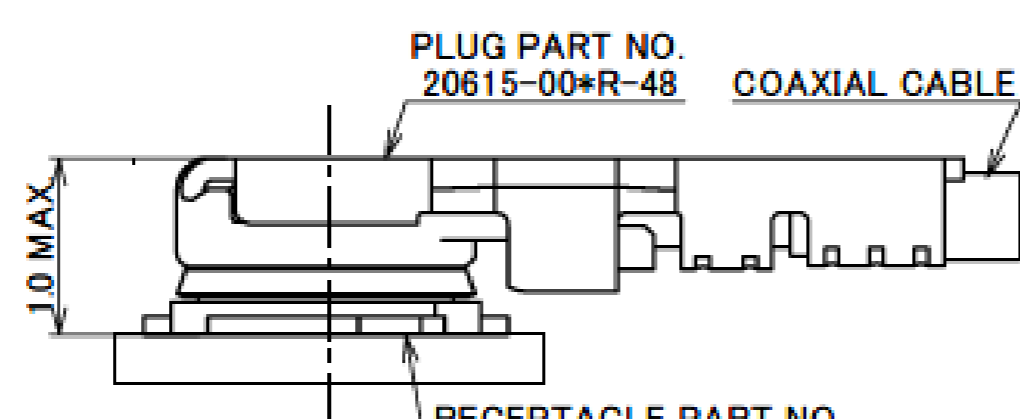
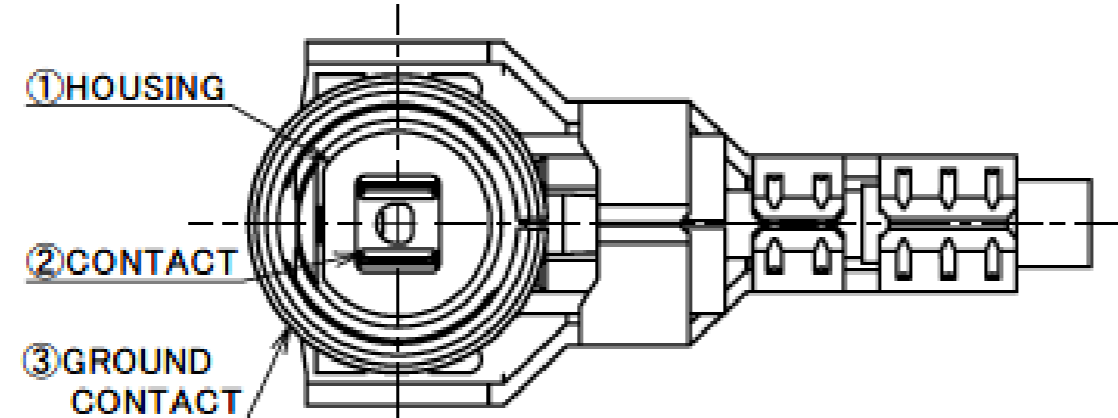
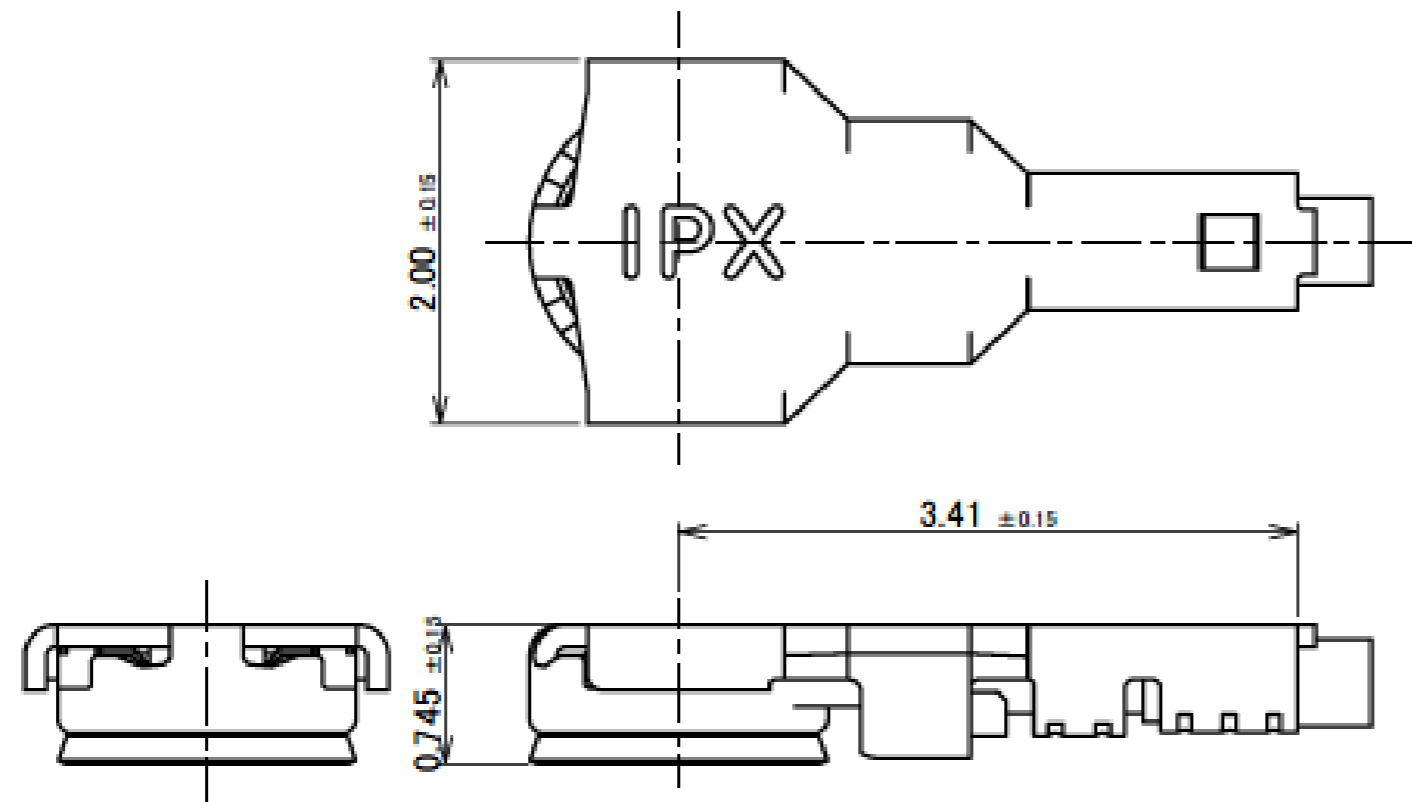

MATING CONDITION

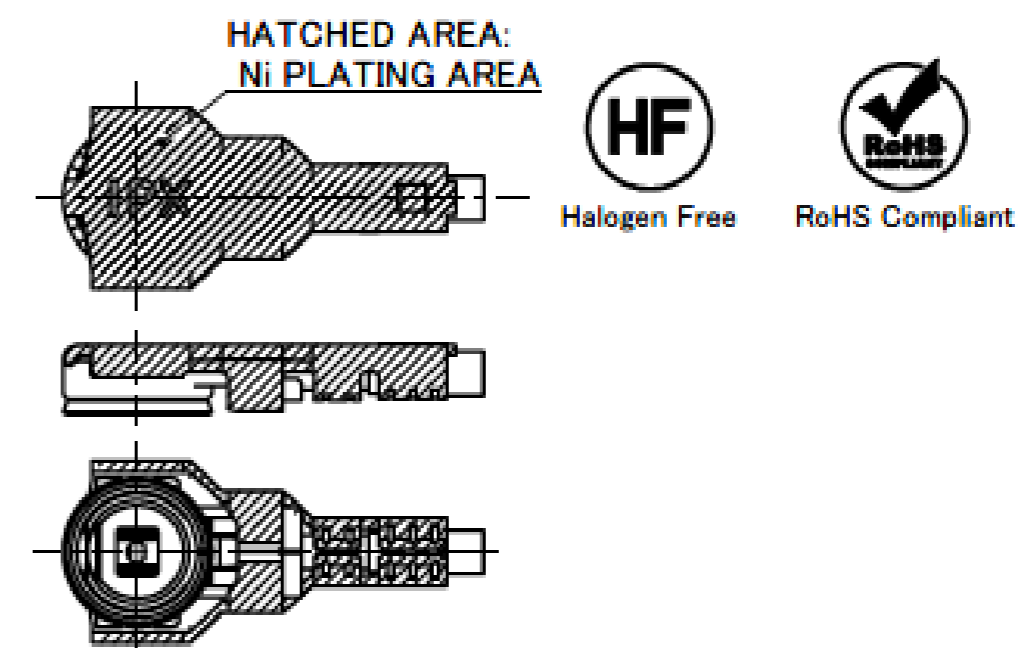
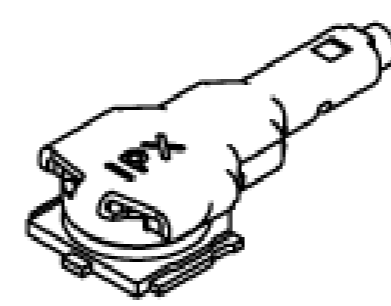

NOTES

1. APPLICABLE CONNECTOR: 20566-001E-01
2. PERMISSIBLE LOAD OF CABLE AT MATING
3. MATING AND UNMATING INSTRUCTION
  - 3-1. MATING  
MATE THE CONNECTOR VERTICALLY AS MUCH AS POSSIBLE, ADJUSTING THE MATING AXIS OF PLUG AND RECEPTACLE. DO NOT SLANT MATE.
  - 3-2. UNMATING
    - 3-2-1. IN CASE OF UNMATING BY PULLING TOOL (PART NO. 90612-0001): USE THE PULLING TOOL AS THE FOLLOWING DRAWING, AND PULL PLUG TO VERTICAL DIRECTION AS DIRECTLY AS POSSIBLE.
    - 3-2-2. IN CASE OF UNMATING DIRECTLY BY HAND: CATCH THE CATCHING AREA OF PLUG, AND PULL PLUG TO VERTICAL DIRECTION AS DIRECTLY AS POSSIBLE.
4. PRECAUTIONS FOR CABLE POSITION  
THE PLUG SHALL NOT BE PLACED WITHIN 50 DEGREES ANGLE FROM CENTER OF THE SIGNAL CONTACT. TILT THE PLUG AT LEAST 50 DEGREES FROM THE CENTER OF A SIGNAL CONTACT.

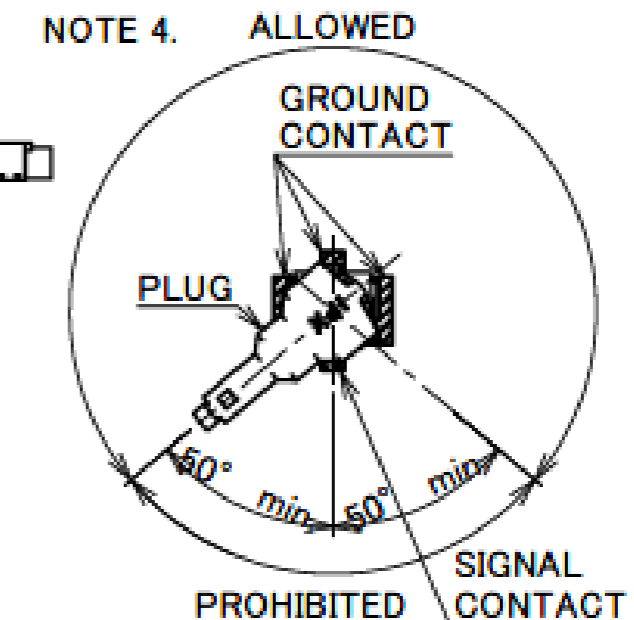
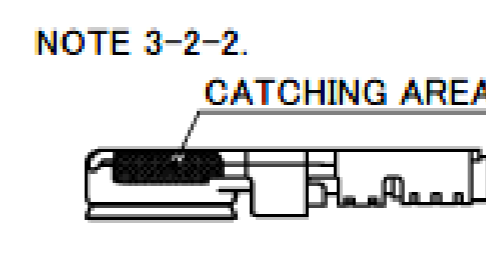
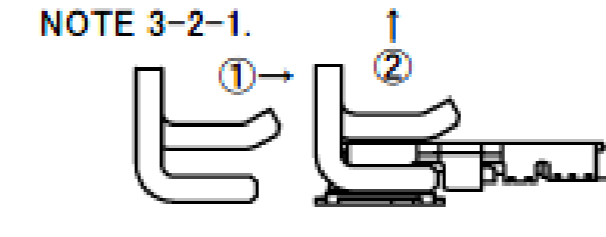
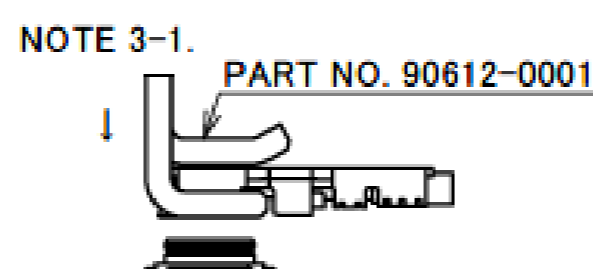
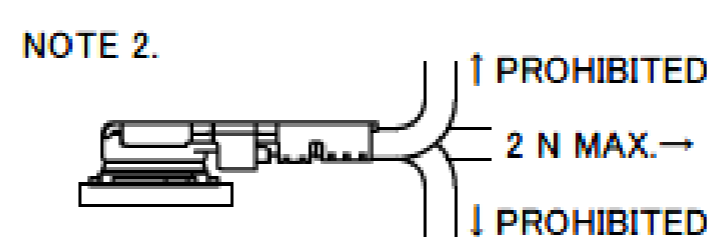

3	GROUND CONTACT	PHOSPHOR BRONZE	ALL OVER Ni 1.00 μm MIN. CONTACT PART Au 0.05 μm MIN.
2	CONTACT	PHOSPHOR BRONZE	ALL OVER Ni 1.00 μm MIN. CONTACT PART Au 0.05 μm MIN.
1	HOUSING	LCP	UL94V-0, BLACK
NO.	DESCRIPTION	MATERIAL	FINISH, REMARKS

Rev.7

# MHF® 5 PLUG Ni top (0.48)

ITEMS	SPECIFICATION	
	PLUG PART No.	20615-001R-48 (ALL Au PLATING TYPE)
RECOMMENDED APPLICABLE CONNECTOR PART No.	20566-001E-01	
RATING VOLTAGE	60 V AC (R.M.S)	
RATING FREQUENCY	DC~12 GHz	
OPERATING TEMPERATURE	233~363 K (-40°C~+90°C)	
VSWR (MATED WITH SMA ADAPTER PART No. 90543-0001)	1.30 MAX. AT 0.1 ~ 3 GHz, 1.50 MAX. AT 3 ~ 6 GHz, 1.60 MAX. AT 6 ~ 12 GHz	
MAIN CONTACT RESISTANCE	INITIAL: 20 mohm MAX. / AFTER TEST: $\angle$ R 20 mohm MAX.	
GROUND CONTACT RESISTANCE	INITIAL: 20 mohm MAX. / AFTER TEST: $\angle$ R 20 mohm MAX.	
INSULATION RESISTANCE	INITIAL: 500 Mohm MIN. / AFTER TEST: 100 Mohm MIN.	
DIELECTRIC WITHSTANDING VOLTAGE	200 V AC, 1 MINUTE	
DURABILITY	30 CYCLES	
UNMATING FORCE (INITIAL / AFTER TEST)	INITIAL: 4 N MIN. / AFTER TEST: 2 N MIN.	
CRIMP STRENGTH	7 N MIN.	
PRODUCT SPECIFICATION	PRS-1939	PRS-2032
TEST REPORT	TR-14026	TR-15029
INSTRUCTION MANUAL	HIM-13003	
APPEARANCE CRITERIA No.	QLS-A***	

Rev.7

# MHF® 5 PLUG Ni top

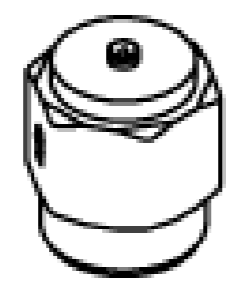

MHF 5 SMA ADAPTOR  
PART NO. 90543-0001



FRONT SIDE



BACK SIDE

MHF 5 PUSHING AND PULLING TOOL  
PART NO. 90612-0001

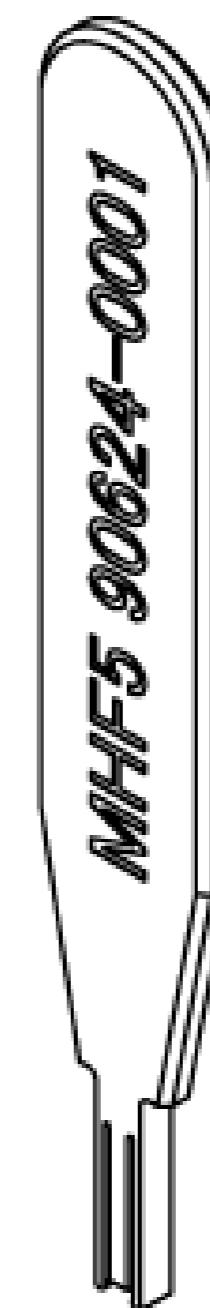

MHF 5 PUSHING TOOL  
PART NO. 90624-0001

Rev.7

# MHF® 5 Receptacle

Recommended P/N	20566-001E-01
PART NO.	20566-001E-01

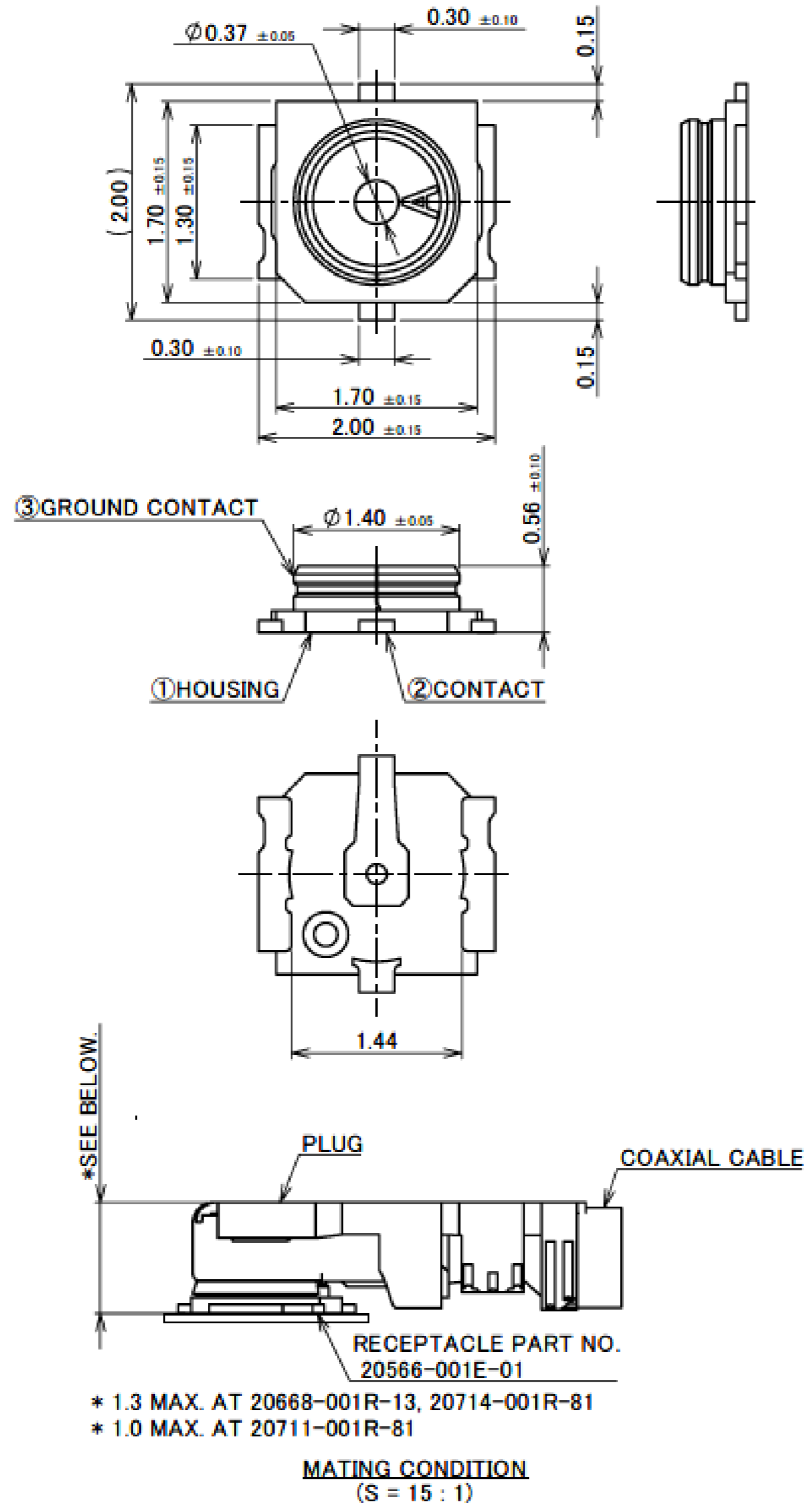

- NOTES
1. APPLICABLE CONNECTOR  
20567-001R-81  
20615-00\*R-48  
20668-001R-13  
20669-001R-81  
20711-001R-81  
20714-001R-81
  2. COPLANARITY: 0.1mm MAX.
  3. THIS IS "Pb-FREE" CONNECTOR.
  4. PRECAUTIONS FOR CABLE POSITION  
[PART NO. 20567-001R-81, 20615-00\*R-48]  
THE PLUG SHALL NOT BE PLACED WITHIN 50 DEGREES ANGLE FROM CENTER OF THE SIGNAL CONTACT.  
TILT THE PLUG AT LEAST 50 DEGREES FROM THE CENTER OF A SIGNAL CONTACT.

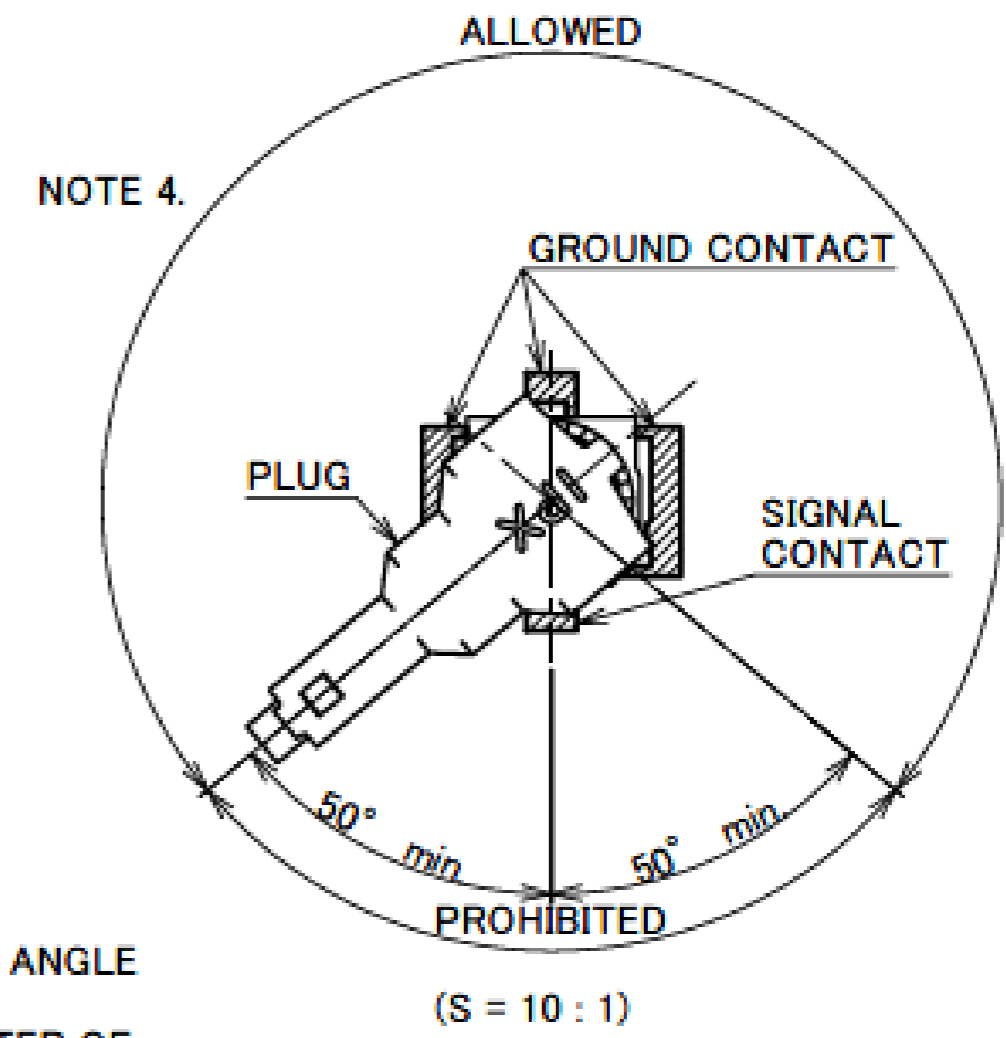

NO.	DESCRIPTION	MATERIAL	FINISH, REMARKS
3	GROUND CONTACT	PHOSPHOR BRONZE	ALL OVER Ni 1.00 μm MIN. CONTACT PART Au 0.01 μm MIN. UNDER PLATE Pd-Ni 0.02 μm MIN. SOLDERING PART Au 0.01 μm MIN. UNDER PLATE Pd-Ni 0.02 μm MIN.
2	CONTACT	BRASS	ALL OVER Ni 1.00 μm MIN. CONTACT PART Au 0.1 μm MIN. SOLDERING PART Au 0.03 μm MIN.
1	HOUSING	LCP	UL94V-0, BLACK

Rev.9

# MHF® 5 Receptacle

ITEMS	SPECIFICATION				
RECOMMENDED APPLICABLE CONNECTOR PART No.	20668-001R-13	20711-001R-81 (CABLE AWG#36 φ0.81)	20714-001R-81	20711-001R-81 (CABLE AWG#36 φ0.64)	20615-001R-48 (ALL Au PLATING TYPE)
RATING VOLTAGE	60 V AC (R.M.S)				
RATING FREQUENCY	DC~15 GHz				
OPERATING TEMPERATURE	233~363 K (-40°C~+90°C)				
VSWR (MATED WITH SMA ADAPTER PART No. 90543-0001)	1.30 MAX. AT 0.1~3 GHz, 1.40 MAX. AT 3~6 GHz, 1.50 MAX. AT 6~12 GHz, 1.65 MAX. AT 12~15 GHz				
MAIN CONTACT RESISTANCE	INITIAL: 20 mohm MAX. / AFTER TEST: ΔR 20 mohm MAX.				
GROUND CONTACT RESISTANCE	INITIAL: 20 mohm MAX. / AFTER TEST: ΔR 100 mohm MAX.				INITIAL: 20 mohm MAX. / AFTER TEST: ΔR 20 mohm MAX.
INSULATION RESISTANCE	INITIAL: 500 Mohm MIN. / AFTER TEST: 100 Mohm MIN.				
DIELECTRIC WITHSTANDING VOLTAGE	200 V AC, 1 MINUTE				
DURABILITY	30 CYCLES				
UNMATING FORCE (INITIAL / AFTER TEST)	INITIAL: 5 N MIN. AFTER TEST: 3 N MIN.	INITIAL: 4 N MIN. AFTER TEST: 2 N MIN.	INITIAL: 5 N MIN. AFTER TEST: 3 N MIN.	INITIAL: 4 N MIN. AFTER TEST: 2 N MIN.	INITIAL: 4 N MIN. AFTER TEST: 2 N MIN.
PRODUCT SPECIFICATION	PRS-2192	PRS-2108	PRS-2236	PRS-2109	PRS-1939
TEST REPORT	TR-16003	TR-15062	TR-16049	TR-15063	TR-14026
PACKING STANDARD	PST-12036				
INSTRUCTION MANUAL	HIM-16014	HIM-16013	HIM-16014	HIM-16013	HIM-13003
APPEARANCE CRITERIA No.	QLS-A***				

Rev.9

# MHF<sup>®</sup> 5 Receptacle

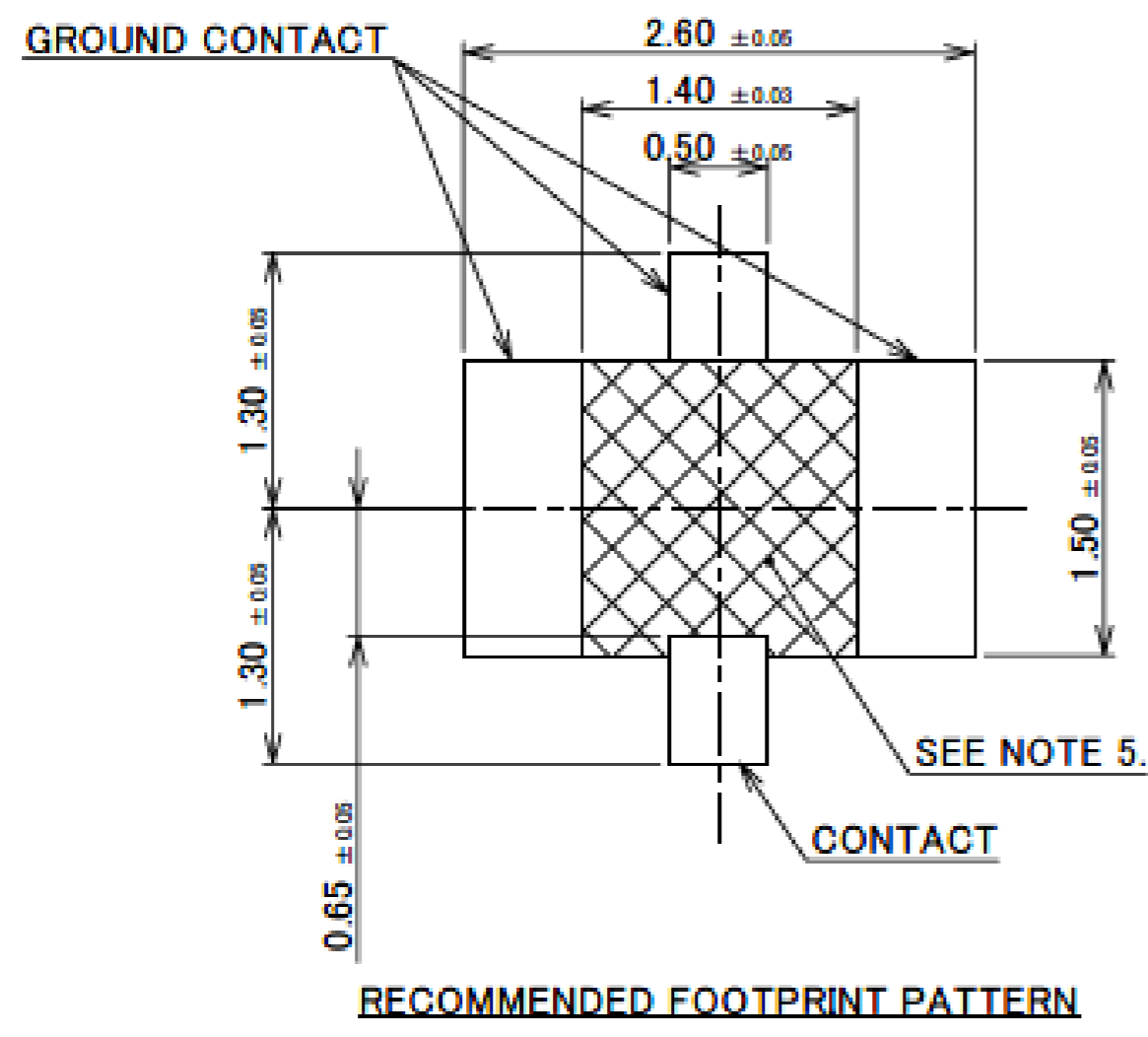

RECOMMENDED FOOTPRINT PATTERN

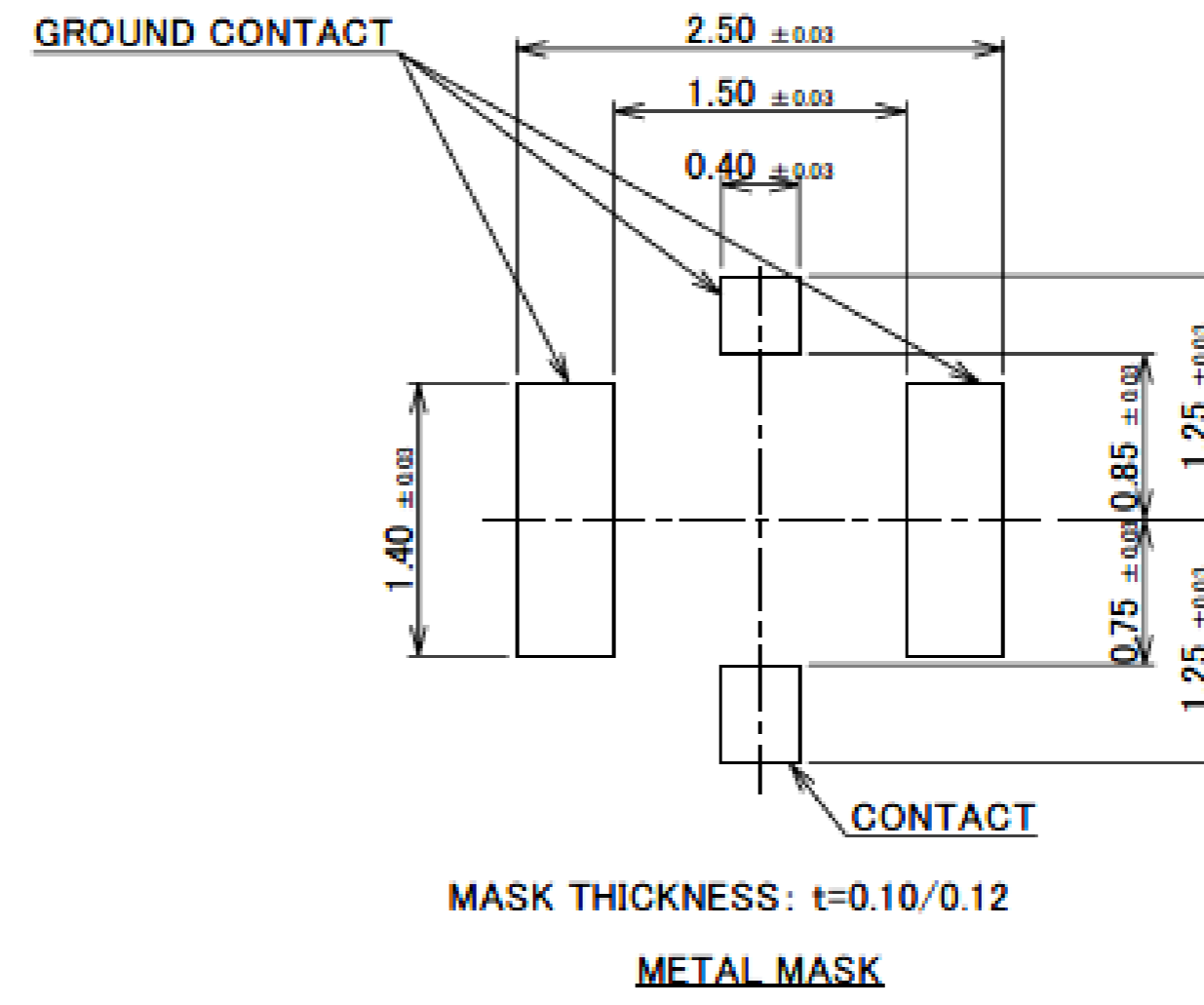

MASK THICKNESS:  $t=0.10/0.12$   
METAL MASK

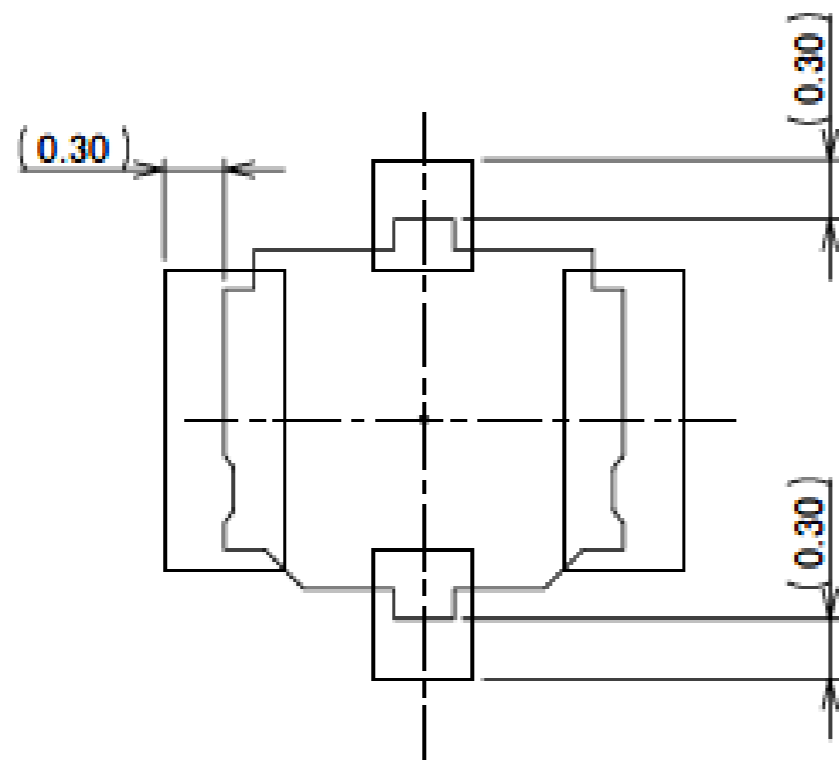

CONNECTOR ON RECOMMENDED FOOTPRINT PATTERN

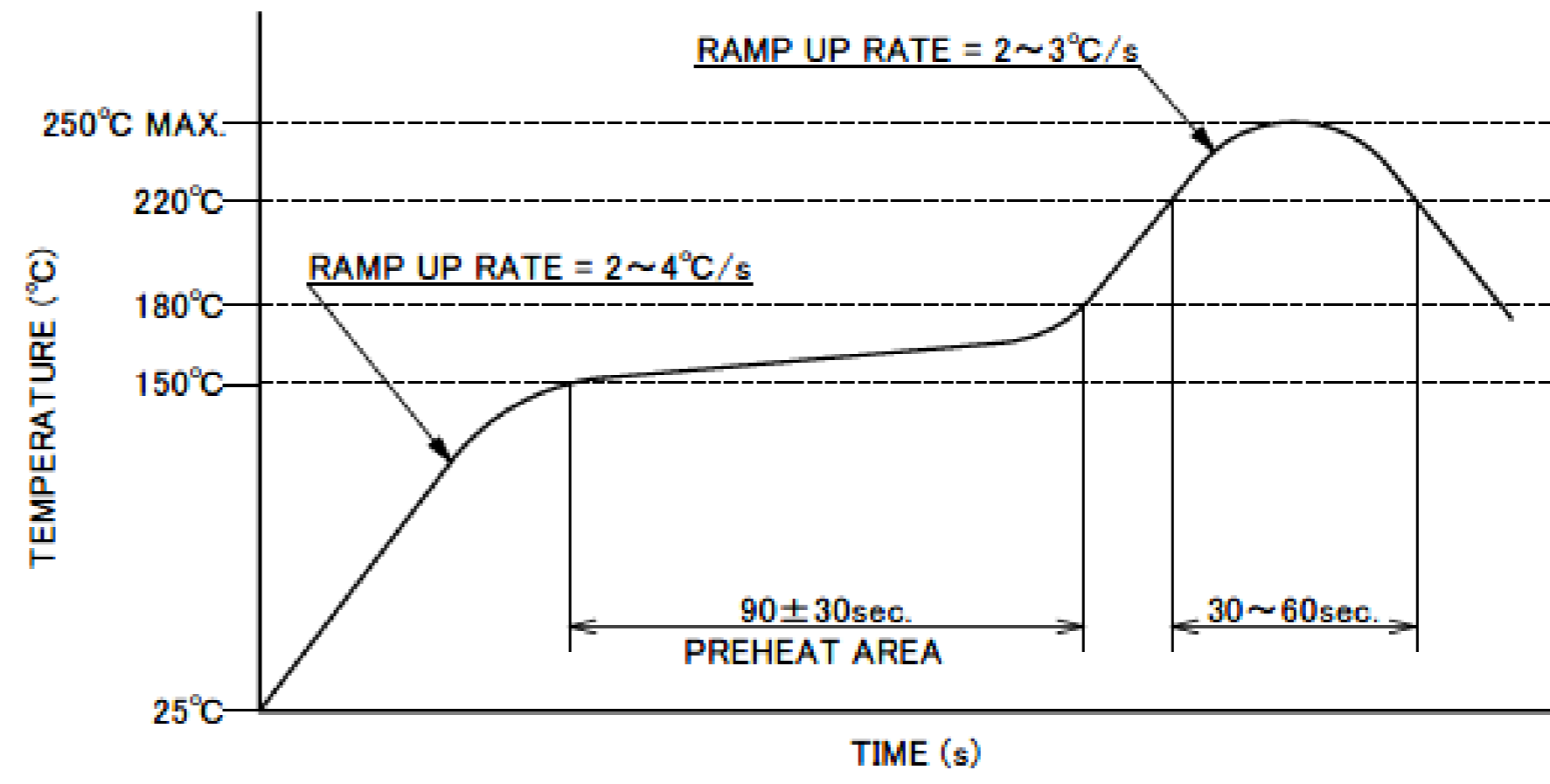

REFLOW TEMPERATURE PROFILE  
SENJU METAL INDUSTRY CO., LTD. : M705-SHF(Sn96.5 Ag3.0 Cu0.5)

NOTES.  
5. NO GROUND, SIGNAL, AND RESIST IN THIS AREA.

Rev.9

# Accessories for MHF<sup>®</sup> 5 Receptacle



MHF 5 SMA ADAPTER  
PART NO. 90543-0001

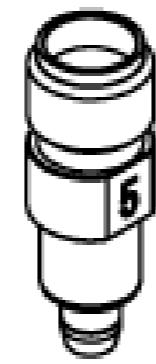

MHF 5 RECEPTACLE HIGH CYCLE ATTACHMENT  
PART NO. 90690-0001

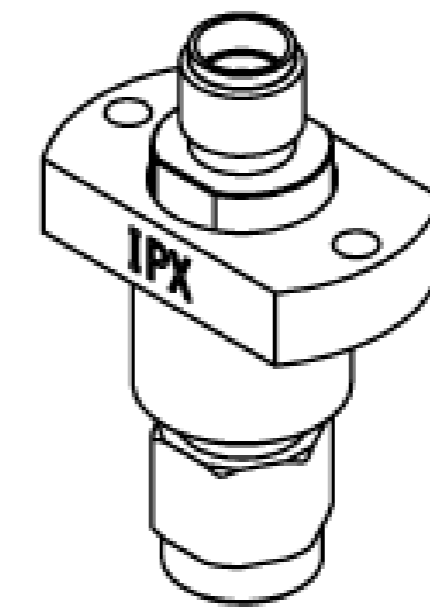

MHF SERIESE HIGH CYCLE ADAP BASE UNIT  
PART NO. 90684-0001

\* 90690-0001 AND 90684-0001 SHOULD BE USED TOGETHER.

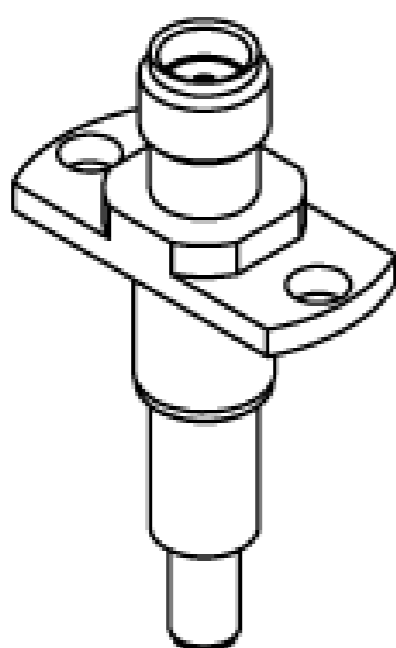

MHF 5 RECEPTACLE HIGH CYCLE SMA ADAPTER  
PART NO. 90793-0001

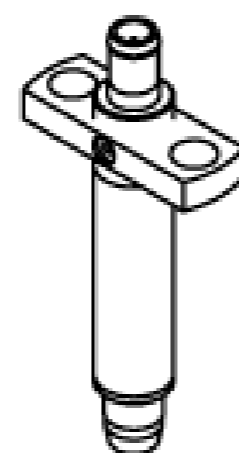

MHF 5 RECEPTACLE HIGH CYCLE N45 C ADAPTER  
PART NO. 90847-0001

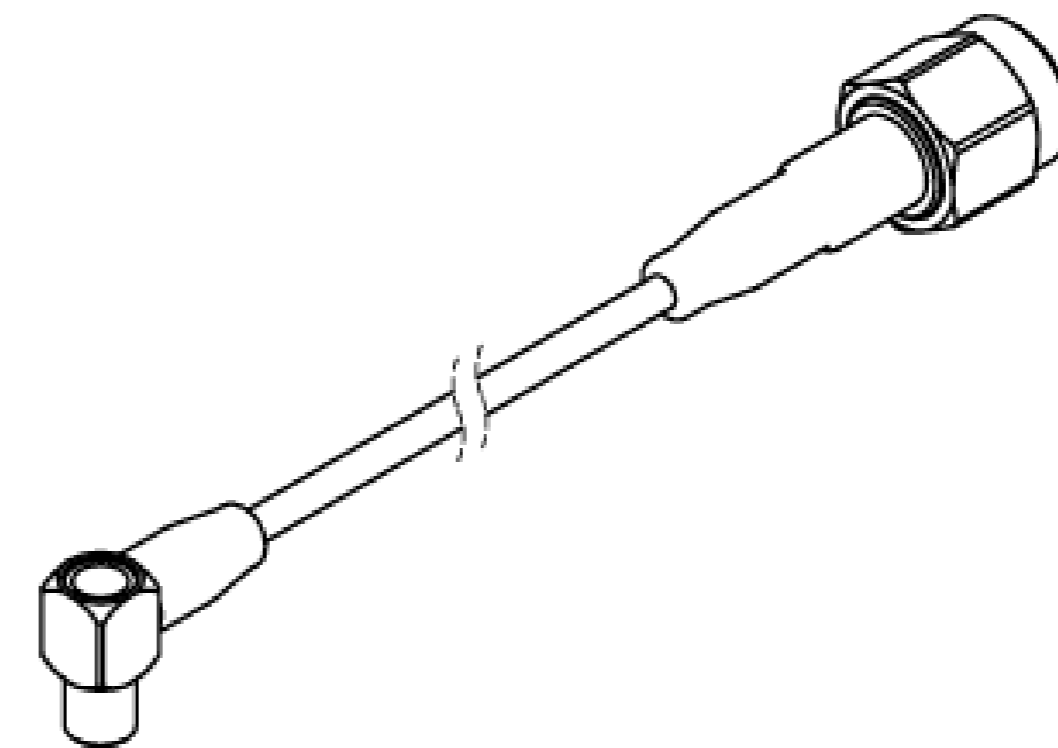

MHF SERIES N45 C TO SMA ADAPTER CABLE  
PART NO. 90577-\*\*\*\*

\* 90847-0001 AND 90577-\*\*\*\* SHOULD BE USED TOGETHER.



# Custom Products Available

## RF Connector

MHF® series



## Micro-coaxial/Twinax/ Discrete Wire Connector

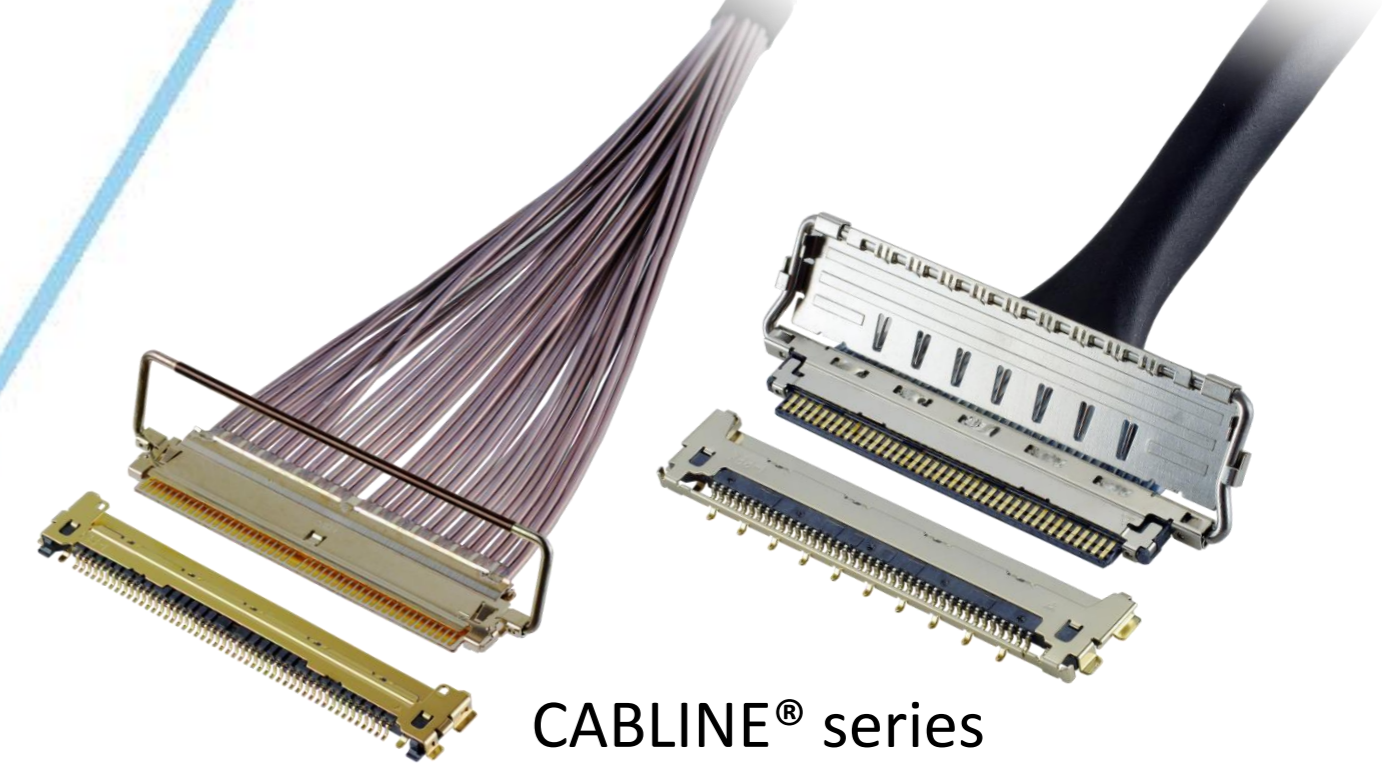

CABLINE® series



## Optical Module

LIGHTPASS® series



NOVASTACK® series

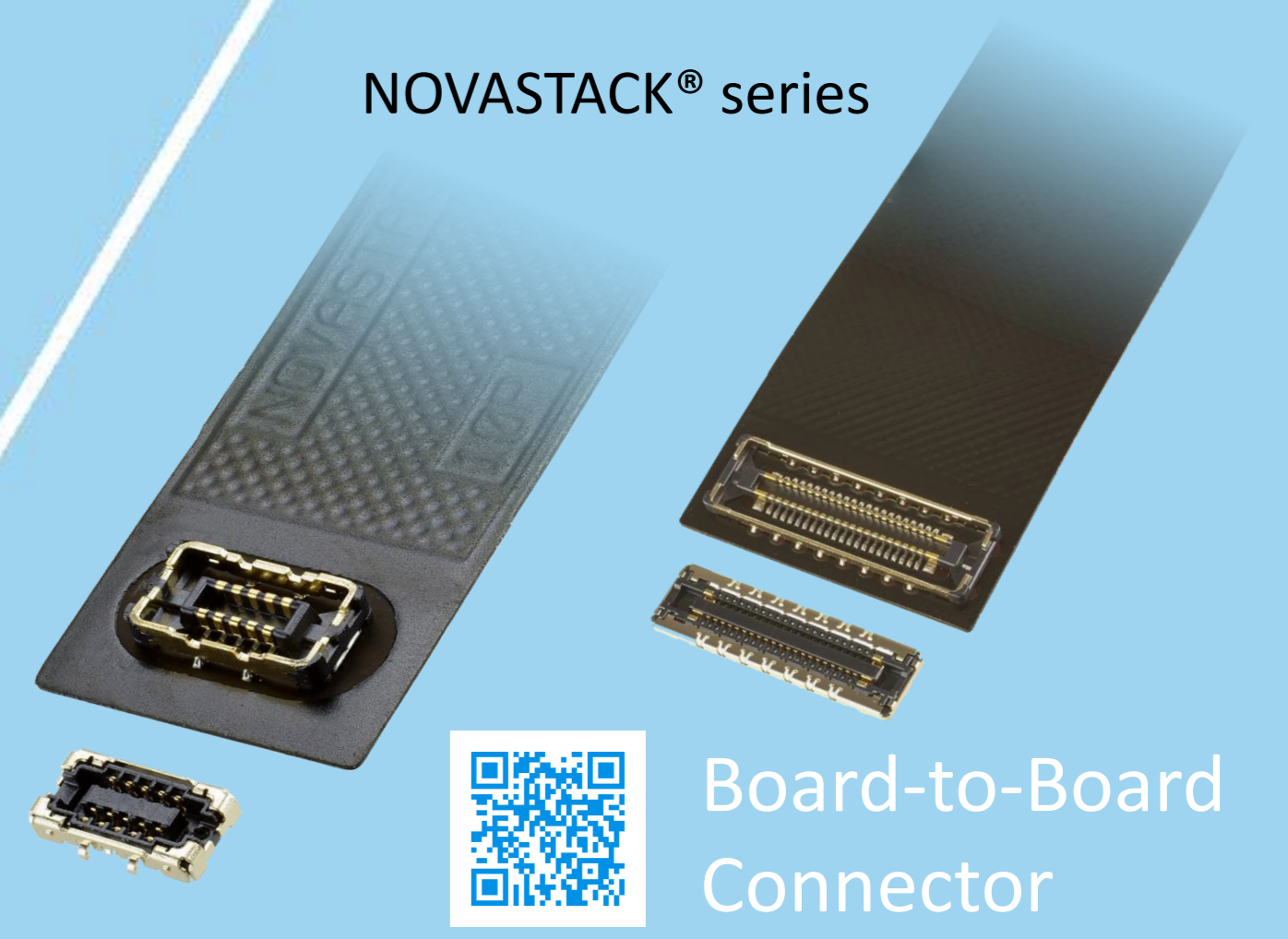

## Board-to-Board Connector



## Power Connector/ Terminal

AP series

ISH® series



MINIFLEX® series

EVAFLEX® series



## FPC FFC Connector



Inquiry



MINIDOCK® series

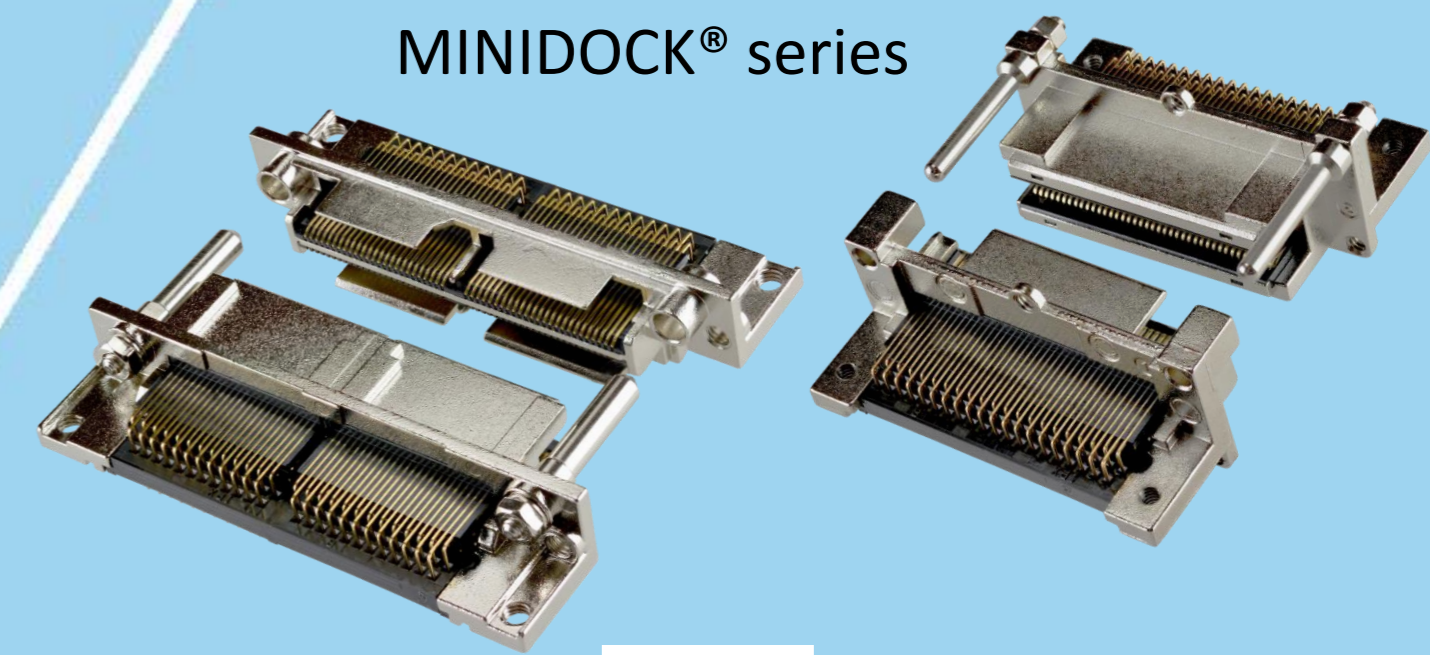

## I/O Connector

I-PEX, MHF, CABLINE, LIGHTPASS, NOVASTACK, ISH, IARPB, MINIFLEX, EVAFLEX, MINIDOCKS and ZenShield are registered trademarks of I-PEX Inc. Please note that the contents in the catalog might be changed without prior notification. I-PEX Inc. assumes no responsibility for any inaccuracies or obligation to update information on these documents. Please be sure to read and understand the latest "Precautions for Use" and "Instruction Manual" before you use our products. We shall not be responsible for any defects, damages or troubles in case you use our products without following the precautions for use. Please feel free to contact our sales representatives when you use our products for any applications that require very high reliability and safety, or that relate to human life (ex. nuclear power control, aerospace, transportation, medical equipment, safety equipment etc.).

Contact your sales representative or more detailed information.

[www.i-pex.com](http://www.i-pex.com)



# I-PEX

© I-PEX Inc. 2024  
All rights reserved