

CABLINE® V

小型化且兼备摩擦力锁扣，支持USB3.1高速数据传输(5Gbps/lane)，触点抗异物能力强，0.4 mm间距，水平插拔方式的细线同轴连接器

Product Specifications:

Mating type	Horizontal	
Board Pitch (mm)	0.4	
Wiping Length (mm)	0.71	
Mated size (mm)	Height	1.0 +/- 0.15
	Width	Formula: 4.8 + (0.4*?p)
	Depth	5.65
Pin Counts	Range	Up to 40
	Available	10, 15, 20, 25, 30, 35, 40

Applicable Cable Size:

Maximum O.D. (mm)	0.4
Micro-Coaxial for Signal (AWG)	45 ohm: #38 or smaller 50 ohm: #40 or smaller
Twinax (AWG)	#40
Discrete (AWG)	#36 or smaller

Applicable Standards (Reference Only):

USB 3.1 Gen 1 (5 Gbps) V-By-One HS 1.4 (4 Gbps)
eDP (2.7 Gbps) MiPi standards

*如您需要了解未列出或不在范围内的Pin数，请咨询我们。



▶ 自带摩擦力锁扣方式，产品小型化设计

宽度 (mm)	4.8+(0.4*?p)
深度 (mm)	5.65

CABLINE V 35p 公母座保持力	
摩擦力锁扣型	12N
非摩擦力锁扣型	8N

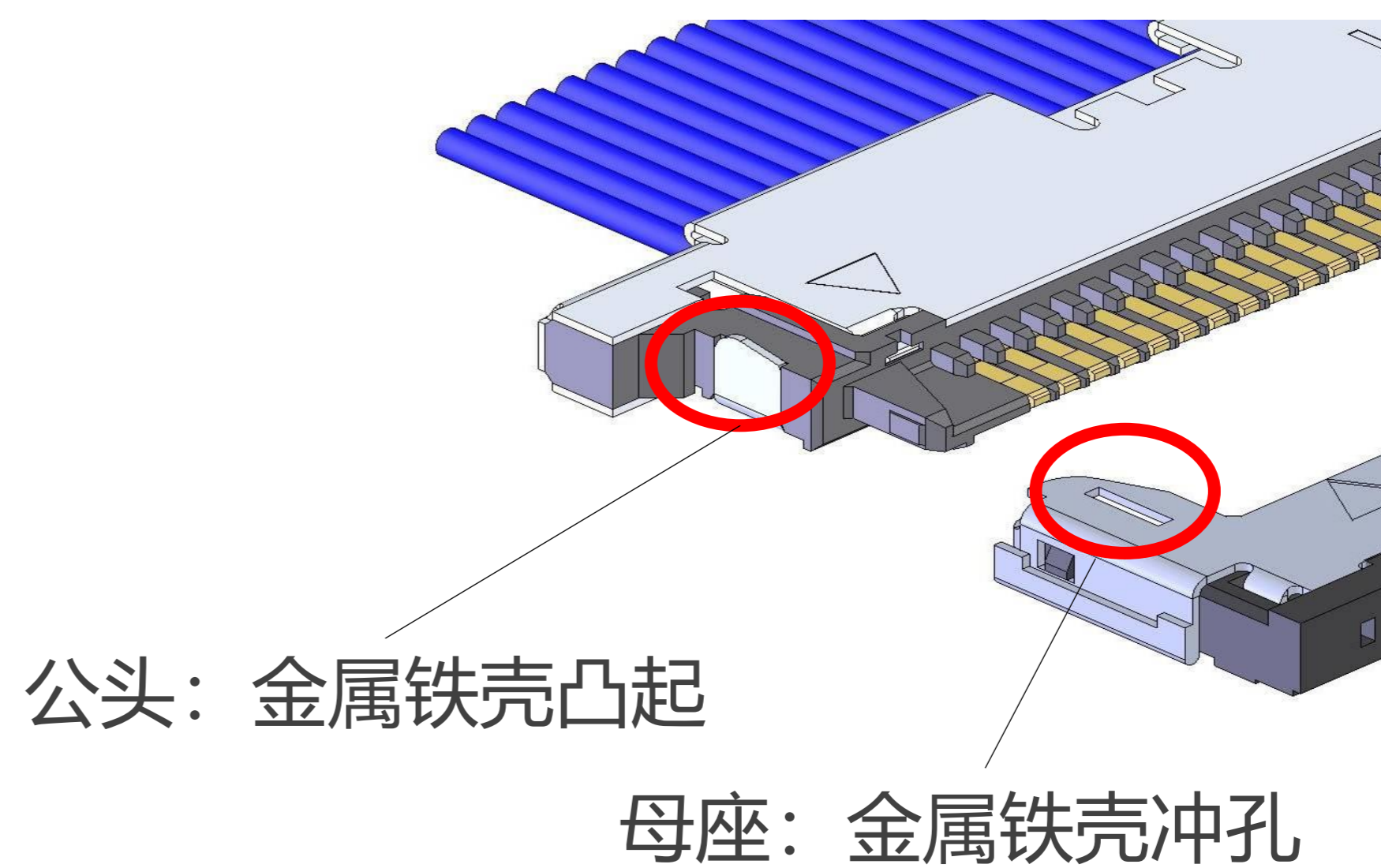

▶ USB 3.1 (5Gbps/lane) 高速率传输应用的理想之选

眼图 (差动传输)

比特率：5Gbps

脉冲上升时间：60ps (10-90%)

输入电压：800mVp-p

*如需更多详细内容，请联系I-PEX相关人员。

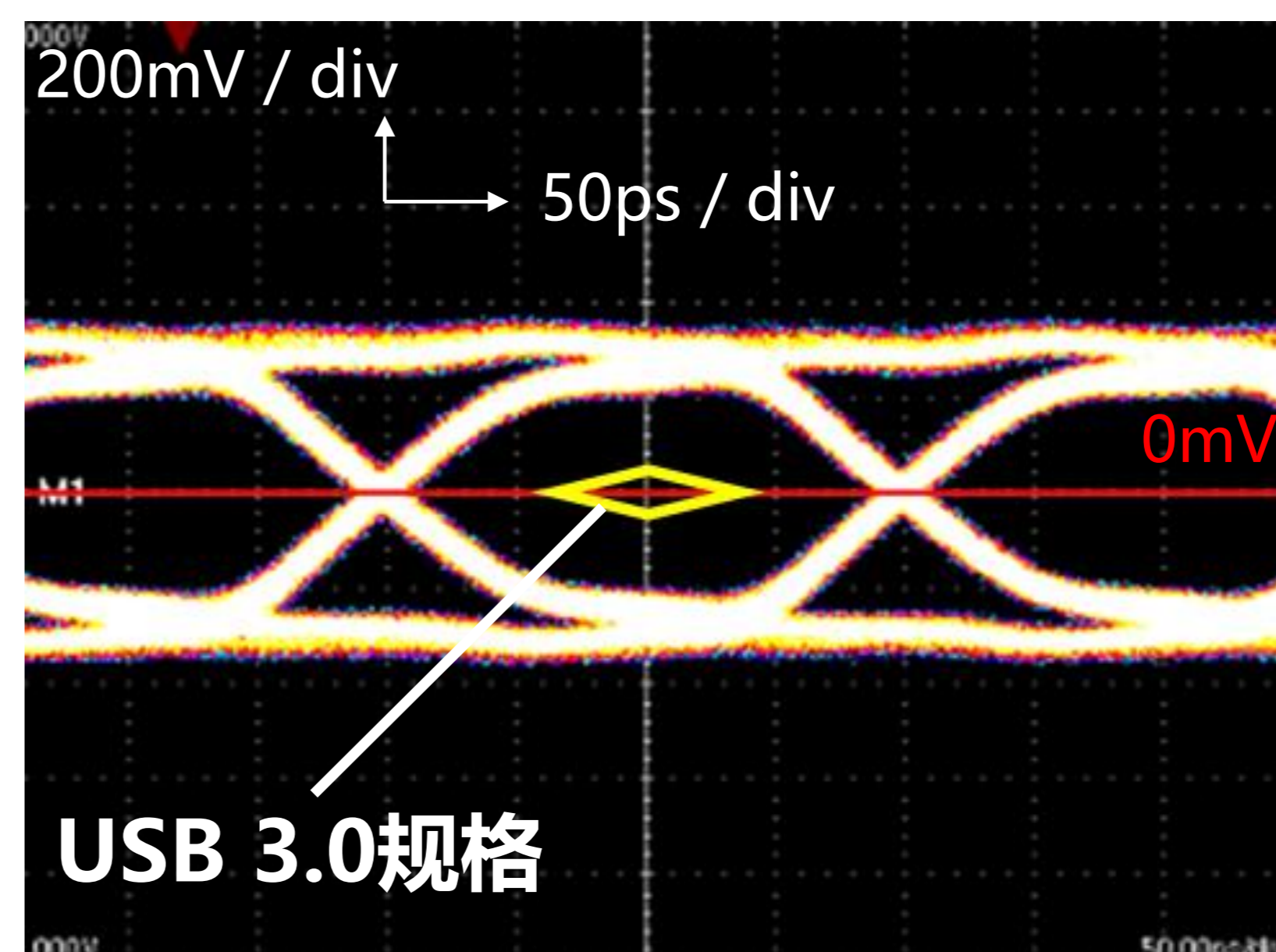

▶ 母座端子采用音叉式设计，插入时可排除异物，导通可靠性强

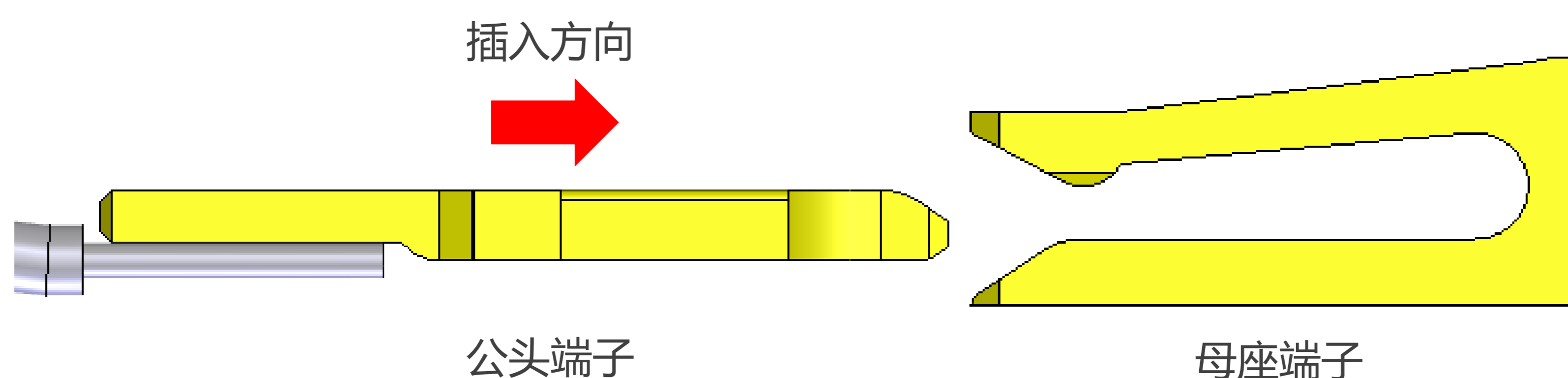

异物在插入过程中被有效除去

Component Parts Details

Component Parts

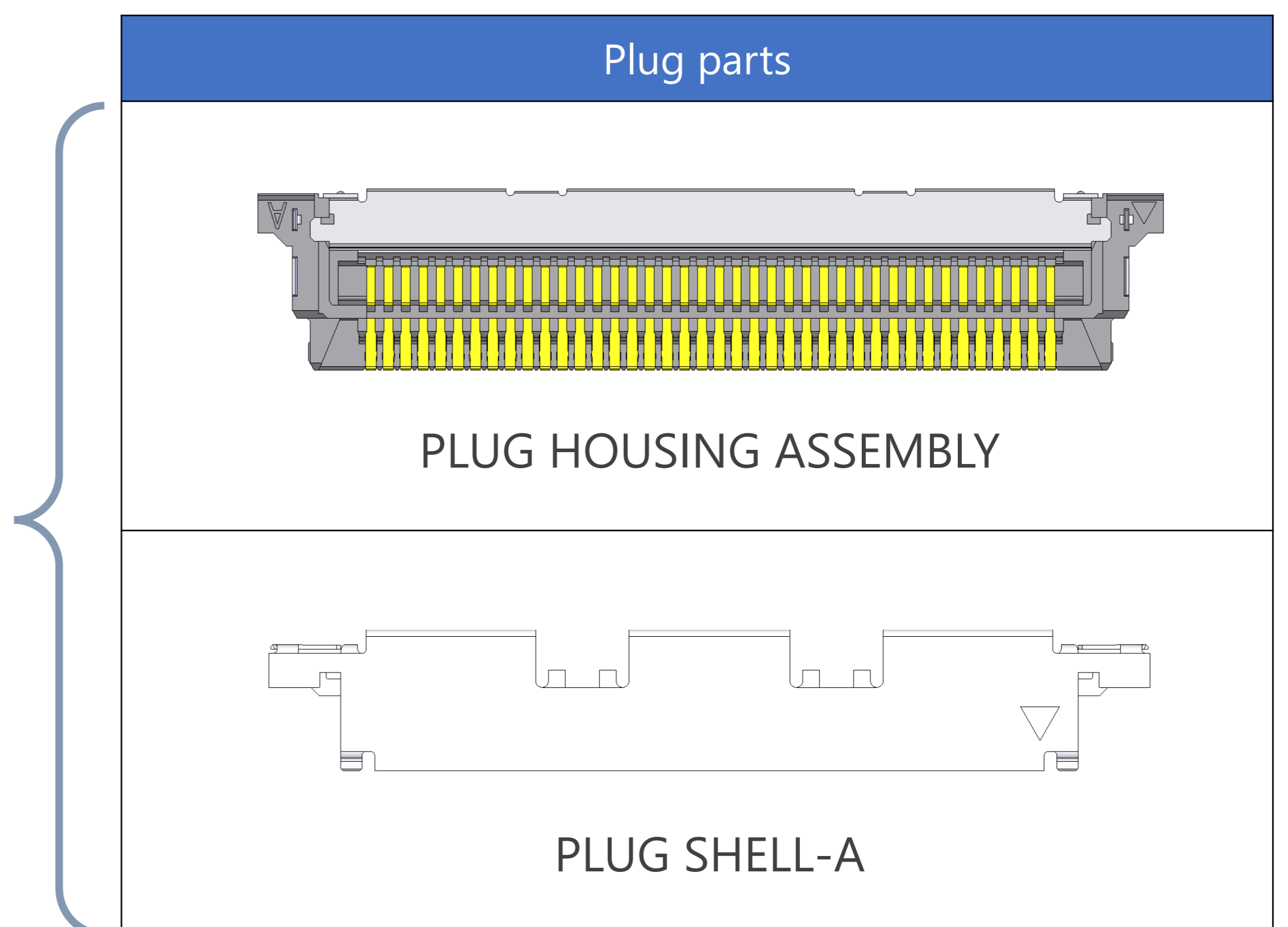
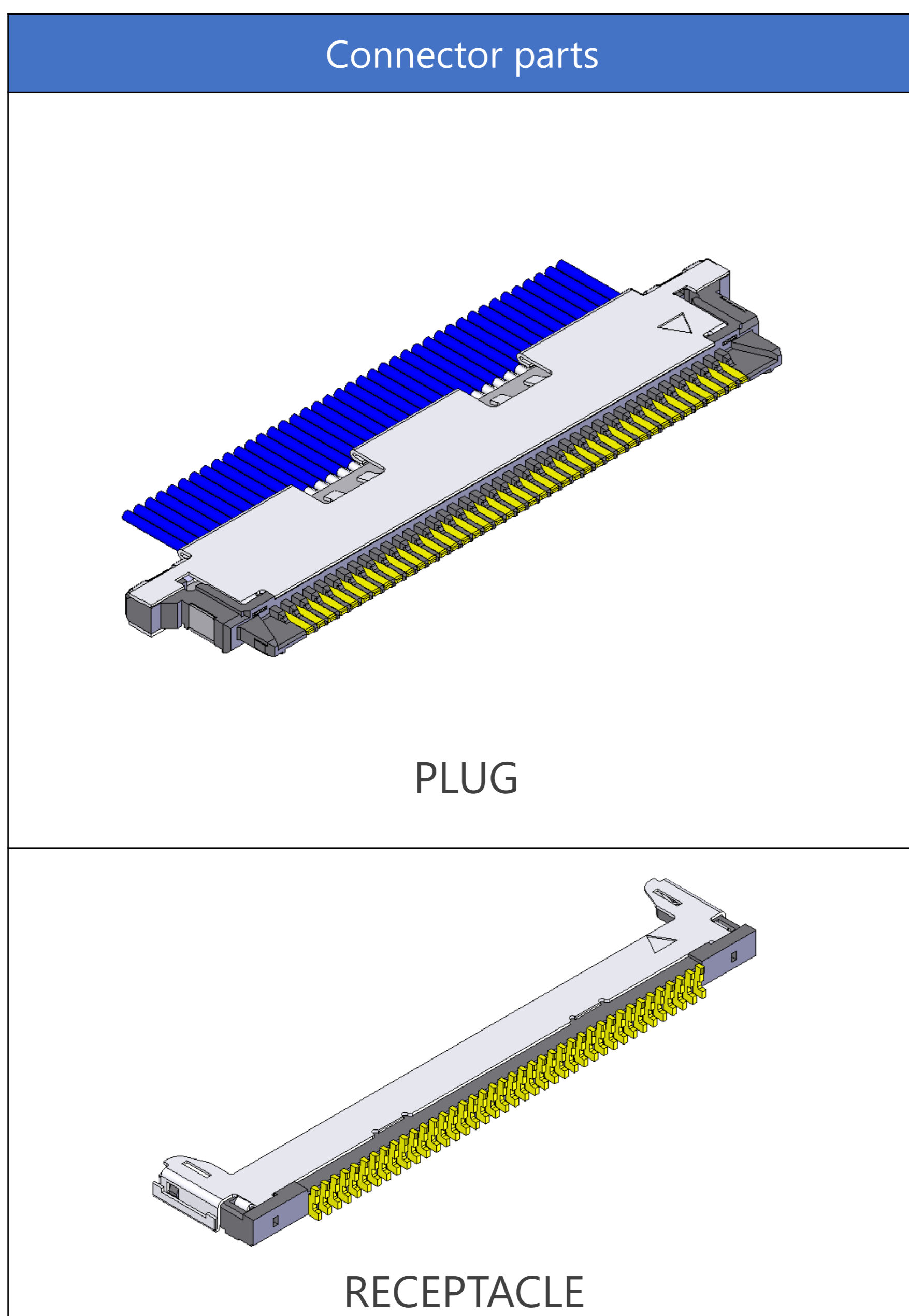

Plug for Cable Assembly

Recommended P/N		20345-0**T-32R				
PART NO.	POS.	A	B	C	D	E
20345-010T-32R	10	3.6	6.4	7.2	8.8	5.4
20345-015T-32R	15	5.6	8.4	9.2	10.8	7.4
20345-020T-32R	20	7.6	10.4	11.2	12.8	9.4
20345-025T-32R	25	9.6	12.4	13.2	14.8	11.4
20345-030T-32R	30	11.6	14.4	15.2	16.8	13.4
20345-035T-32R	35	13.6	16.4	17.2	18.8	15.4
20345-040T-32R	40	15.6	18.4	19.2	20.8	17.4

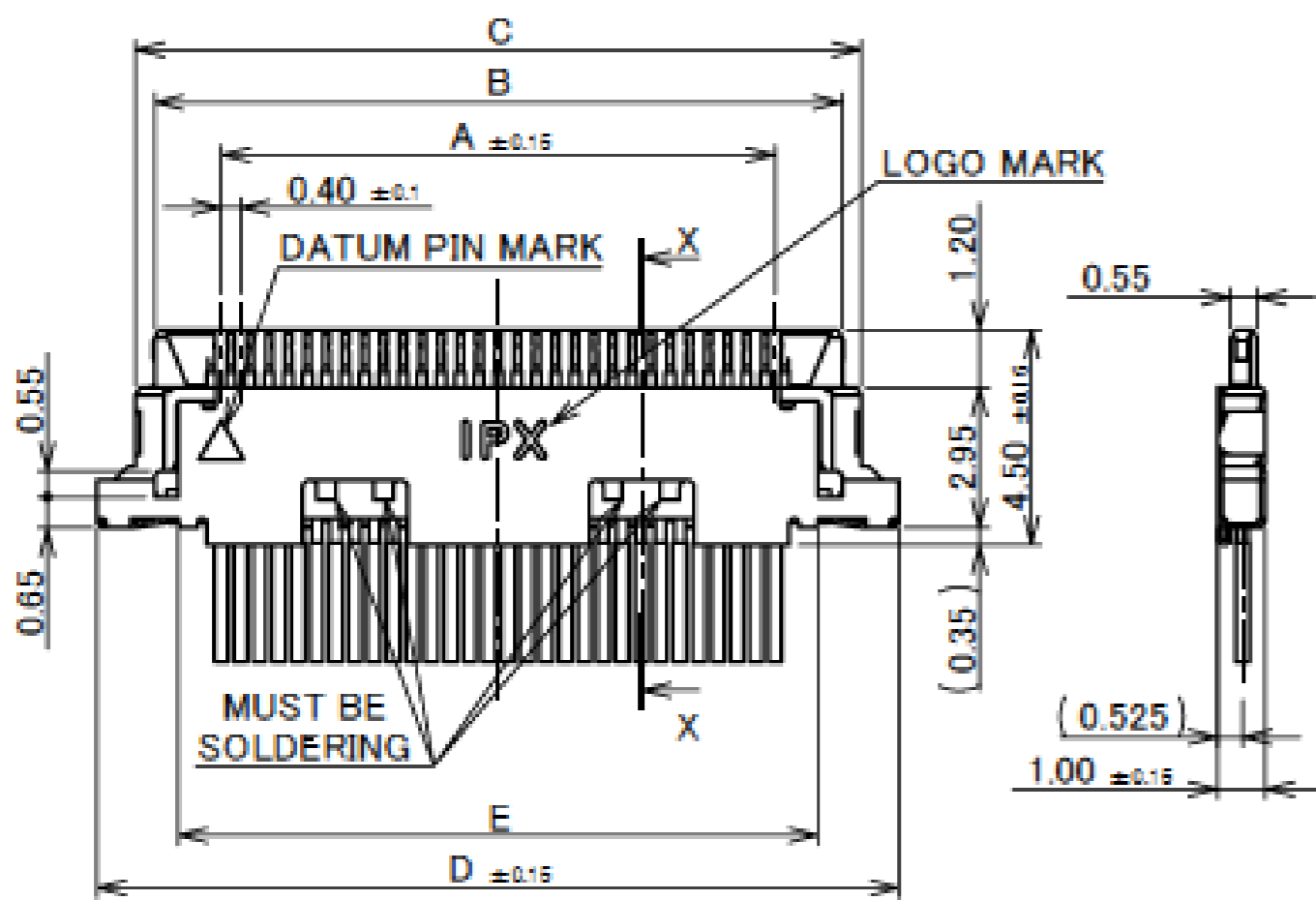
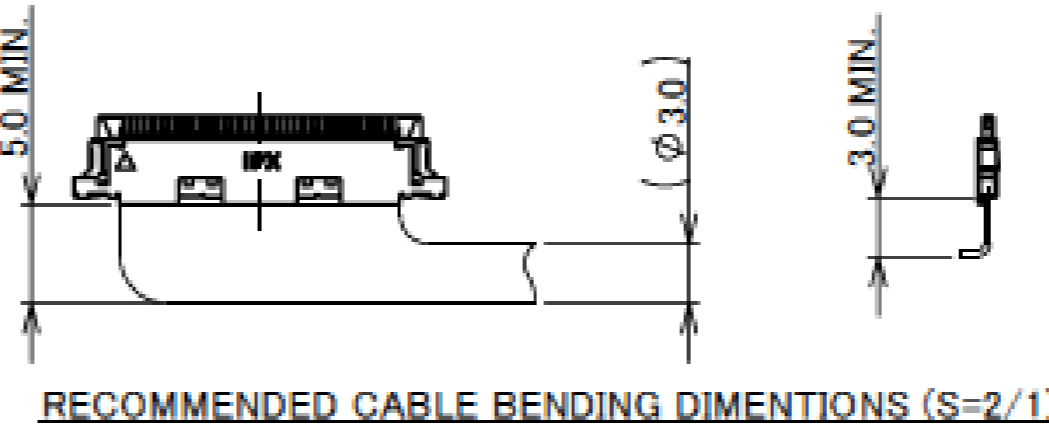
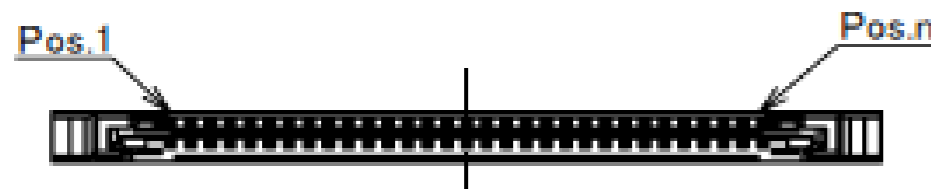
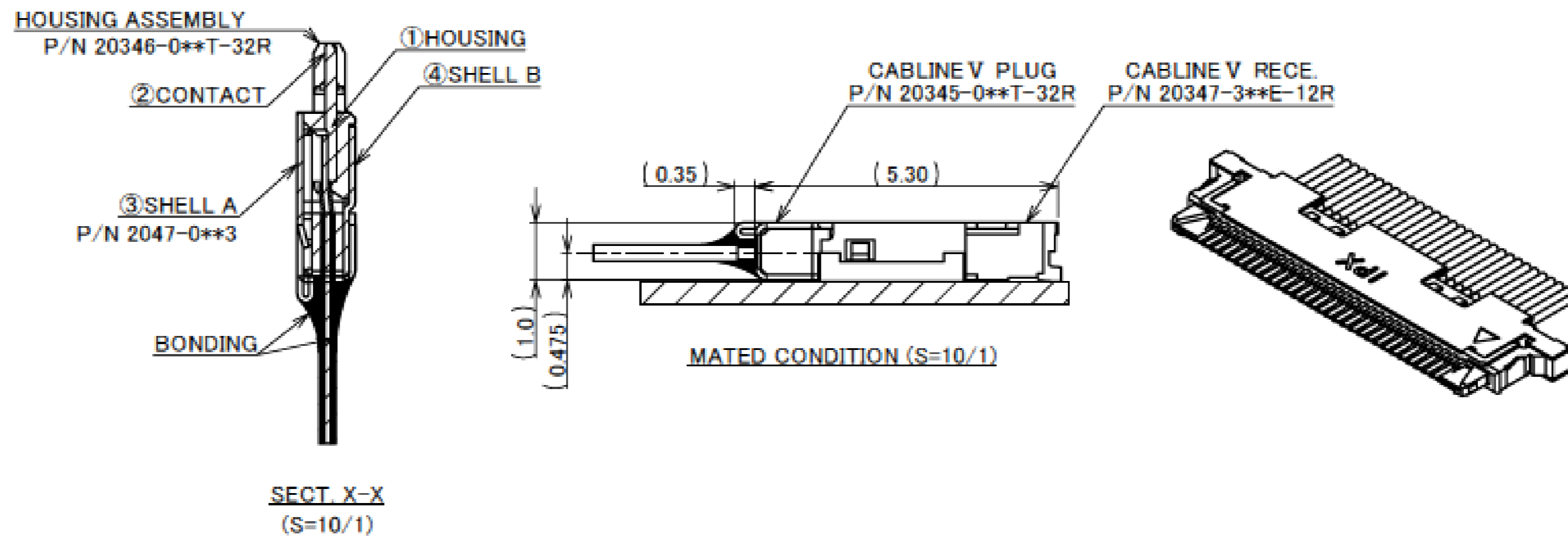
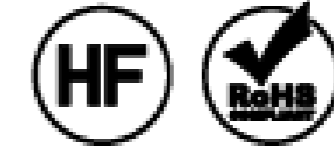

NO	DISCRIPTION	MATERIAL	FINISH , REMARKS
4	SHELL B	PHOSPHOR BRONZE	Sn 1.00 μm MIN. OVER Ni 1.00 μm MIN.
3	SHELL A	SUS	Sn 1.00 μm MIN. OVER Ni 0.50 μm MIN.
2	CONTACT	BRASS	ALL OVER: Ni 1.00 μm MIN. UNDER PLATING CONTACT AREA: Au 0.10 μm MIN. SOLDERING AREA: Au 0.03 μm MIN.
1	HOUSING	LCP	UL94V-0, BRACK

Rev.28

PART NO.	POS.	A	F
20345-010T-32R	10	3.6	4.6
20345-015T-32R	15	5.6	6.6
20345-020T-32R	20	7.6	8.6
20345-025T-32R	25	9.6	10.6
20345-030T-32R	30	11.6	12.6
20345-035T-32R	35	13.6	14.6
20345-040T-32R	40	15.6	16.6

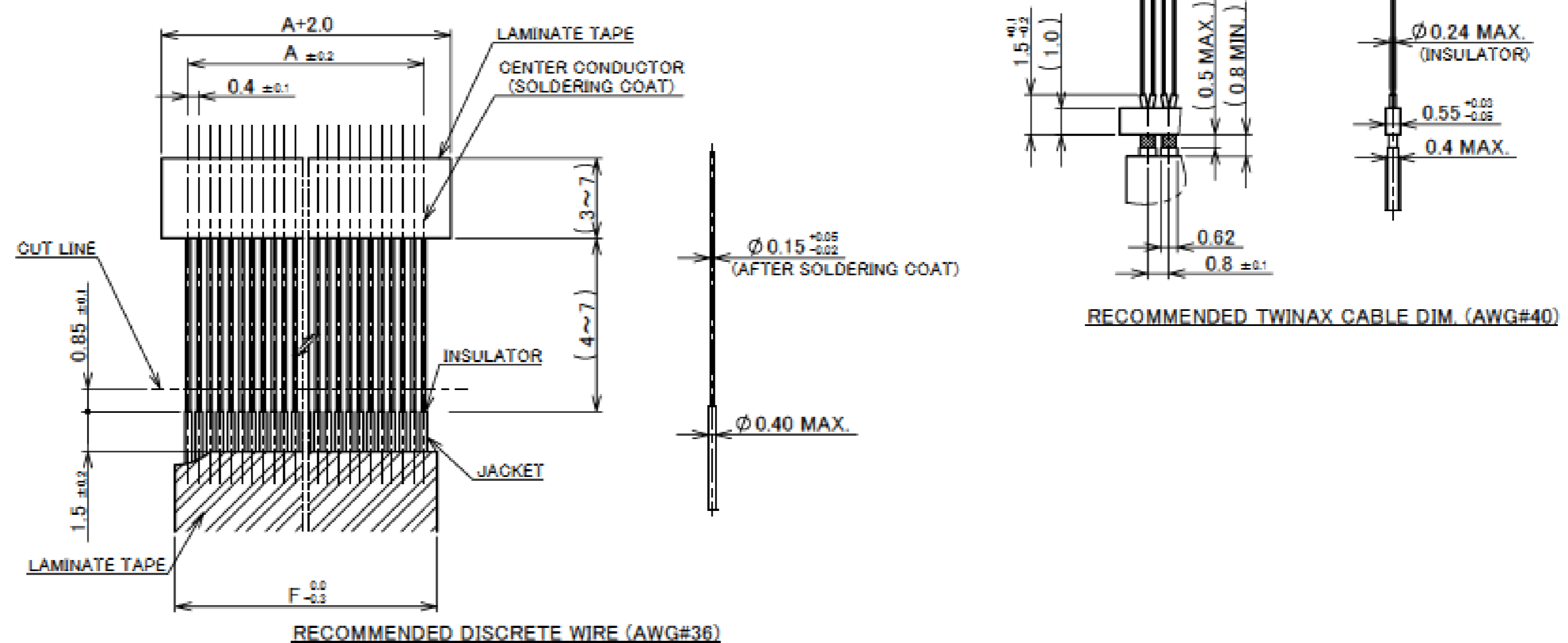
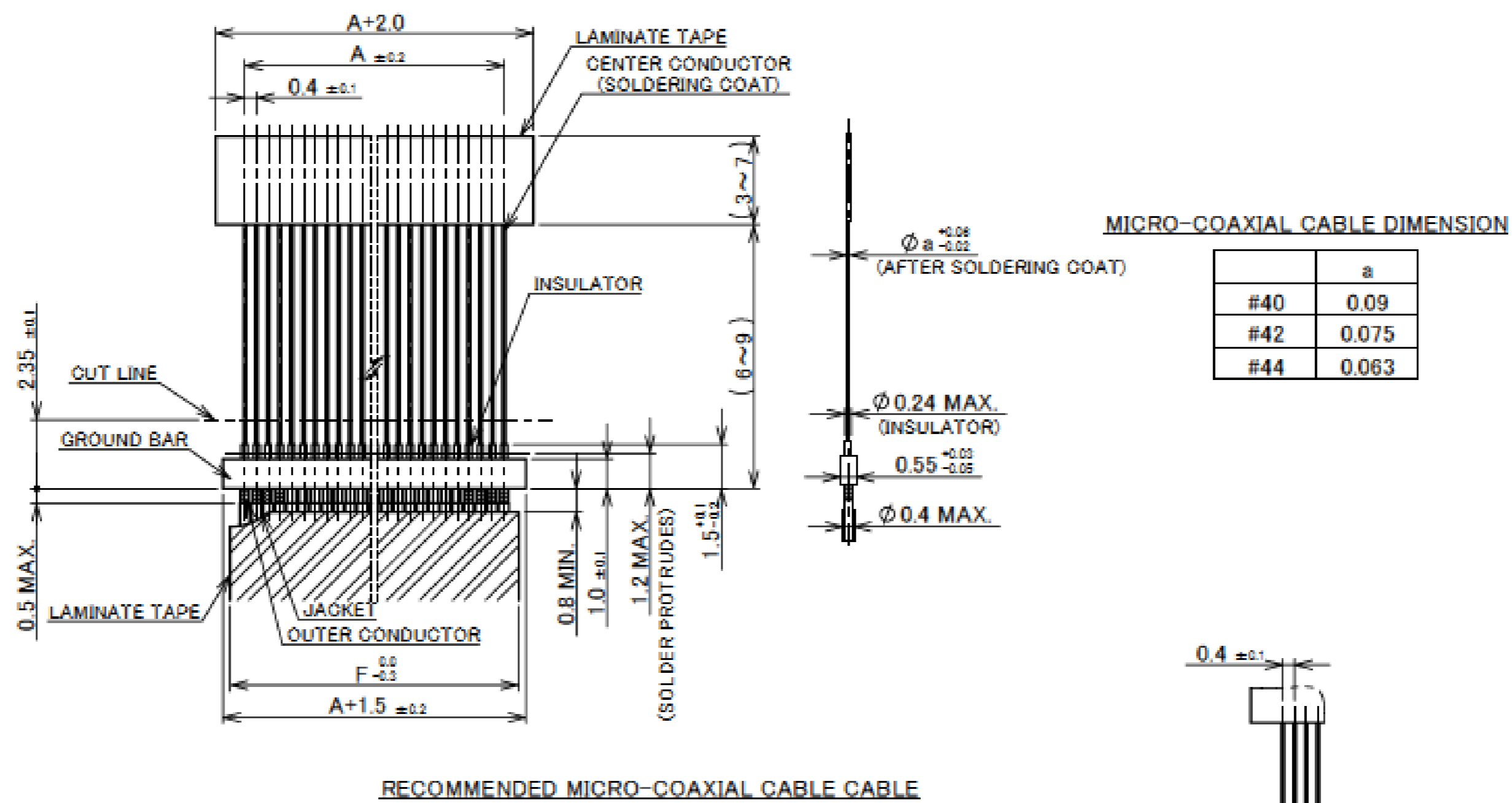

Rev.28

Plug for Cable Assembly

ITEMS	SPECIFICATION
APPLICABLE CABLE	MICRO-COAXIAL CABLE : AWG# 44,42,40 DISCRETE WIRE : AWG# 36 TWINAX CABLE : AWG# 40
RATING VOLTAGE	100V AC (PER CONTACT PIN)
RATING AMPERAGE (FOR CONTACT)	0.1A AC/DC [AWG#44] (PER CONTACT PIN / UP TO 40 CONTACTS) 0.24A AC/DC [AWG#42] (PER CONTACT PIN / UP TO 40 CONTACTS) 0.3A AC/DC [AWG#40] (PER CONTACT PIN / UP TO 40 CONTACTS) 0.8A AC/DC [AWG#36] (PER CONTACT PIN / UP TO 12 CONTACTS) ※TESTING BY A REAL MACHINE IS RECOMMENDED BECAUSE TEMPERATURE RISE MAY AFFECTED BY ACTUAL SITUATION.
OPERATING TEMPERATURE	233~358K(-40°C~+85°C)
OPERATING HUMIDITY	85% MAX.(NON-CONDENSING)
CONTACT RESISTANCE	INITIAL : 235mohm MAX.(AWG#36) / AFTER TEST : \triangle 140mohm MAX. 560mohm MAX.(AWG#40) 650mohm MAX.(AWG#42) 1040mohm MAX.(AWG#44)
GROUND SHELL RESISTANCE	INITIAL : 50mohm MAX. / AFTER TEST : \triangle 140mohm MAX.
INSULATION RESISTANCE	INITIAL : 1000Mohm MIN. / AFTER TEST : 500Mohm MIN.
DIELECTRIC WITHSTANDING VOLTAGE	AC250V 1min
DURABILITY	30 CYCLES
MATING FORCE (INITIAL / AFTER TEST)	10P : 20.0N MAX. 15P : 22.5N MAX. 20P : 25.0N MAX. 25P : 27.5N MAX. 30P : 30.0N MAX. 35P : 32.5N MAX. 40P : 35.0N MAX.
UNMATING FORCE (INITIAL / AFTER TEST)	10P : 4.0N MIN. 15P : 5.0N MIN. 20P : 5.5N MIN. 25P : 6.0N MIN. 30P : 7.0N MIN. 40P : 8.5N MIN.
CABLE RETENTION FORCE	10P : 4.90N MIN. 15P : 7.35N MIN. 20P : 9.80N MIN. 25P : 12.25N MIN. 30P : 14.70N MIN. 35P : 17.15N MIN. 40P : 19.60N MIN.
PRODUCT SPECIFICATION	P/N : 20345-0**T-32R *** PRS-1461
TEST REPORT	P/N : 20345-0**T-32R *** TR-08068
INSTRUCTION MANUAL	HIM-03005
ASSEMBLY MANUAL	ASM-03002
APPEARANCE CRITERIA NO.	QLS-A***

Rev.28

Plug Housing Assembly

Recommended P/N	20346-0**T-32R					
PART NO.	POS.	A	B	C	D	E
20346-010T-32R	10	3.6	6.4	7.2	8.8	5.1
20346-015T-32R	15	5.6	8.4	9.2	10.8	7.1
20346-020T-32R	20	7.6	10.4	11.2	12.8	9.1
20346-025T-32R	25	9.6	12.4	13.2	14.8	11.1
20346-030T-32R	30	11.6	14.4	15.2	16.8	13.1
20346-035T-32R	35	13.6	16.4	17.2	18.8	15.1
20346-040T-32R	40	15.6	18.4	19.2	20.8	17.1

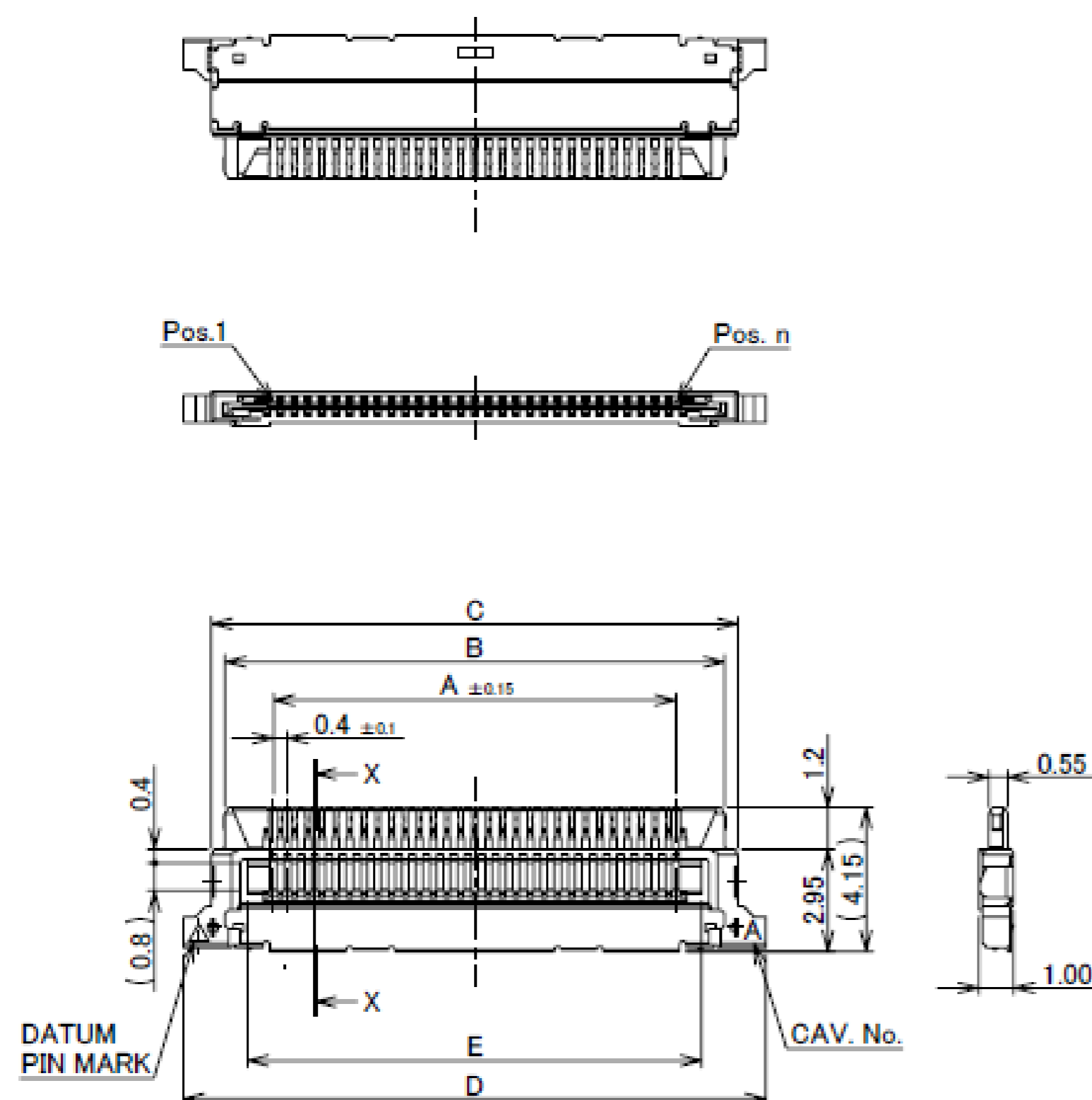
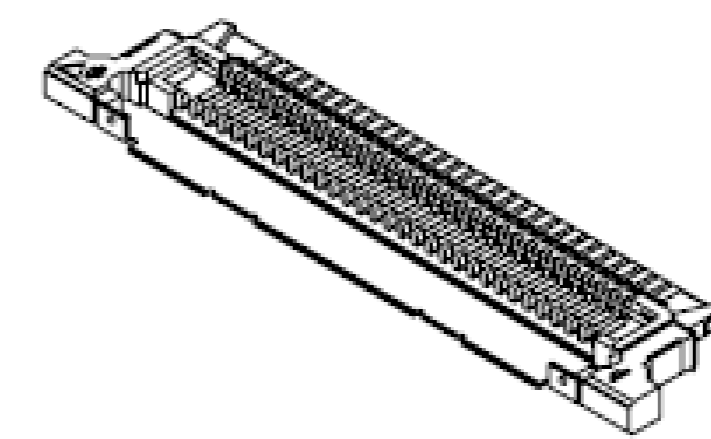
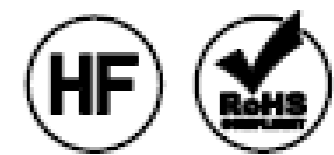

NO.	DISCRIPTION	MATERIAL	FINISH , REMARKS
3	SHELL B	PHOSPHOR BRONZE	Sn 1.00 μ m OVER Ni 1.00 μ m MIN.
2	CONTACT	BRASS	ALL OVER: Ni 1.00 μ m MIN. UNDER PLATING CONTACT AREA: Au 0.10 μ m MIN. SOLDERING AREA: Au 0.03 μ m MIN.
1	HOUSING	LCP	UL94V-0, BRACK

Rev.22

Plug Shell-A

Recommended P/N		2047-0**3			
PART NO.	A	B	C	D	
2047-0103	8.8	4.6	19.5	5.4	
2047-0153	10.8	6.6	19.5	7.4	
2047-0203	12.8	8.6	19.5	9.4	
2047-0253	14.8	10.6	27.5	11.4	
2047-0303	16.8	12.6	27.5	13.4	
2047-0353	18.8	14.6	27.5	15.4	
2047-0403	20.8	16.6	27.5	17.4	

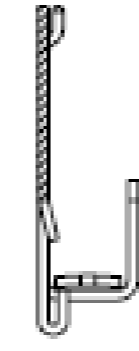
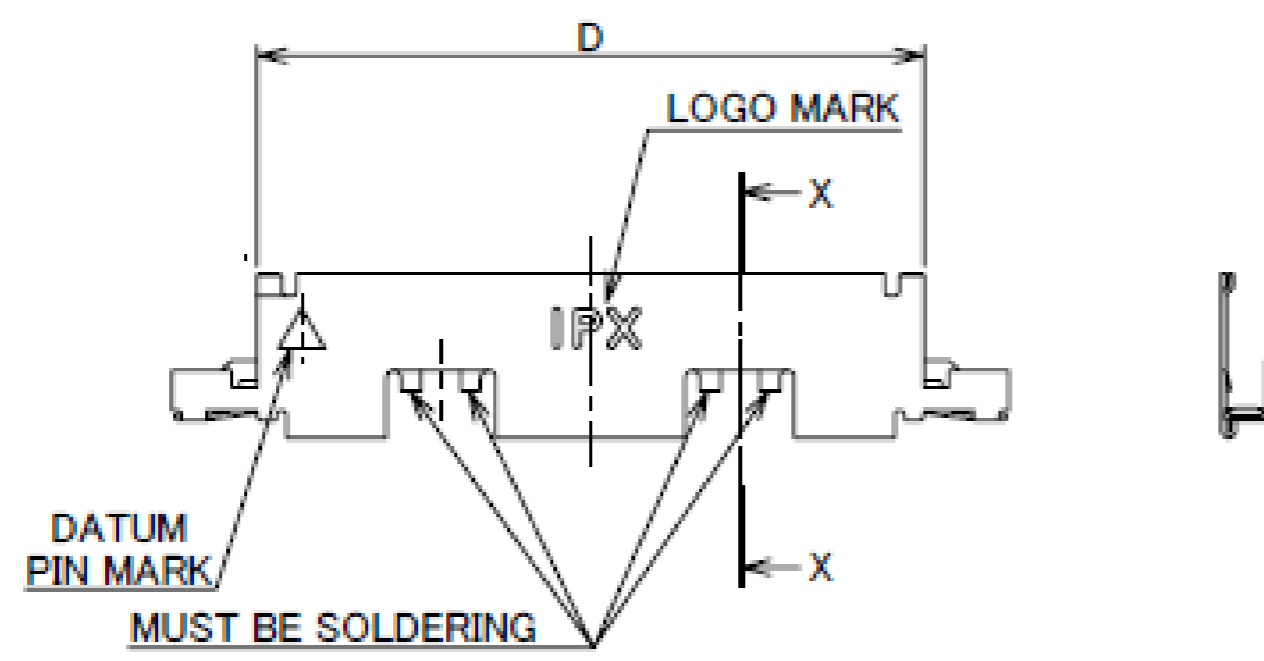
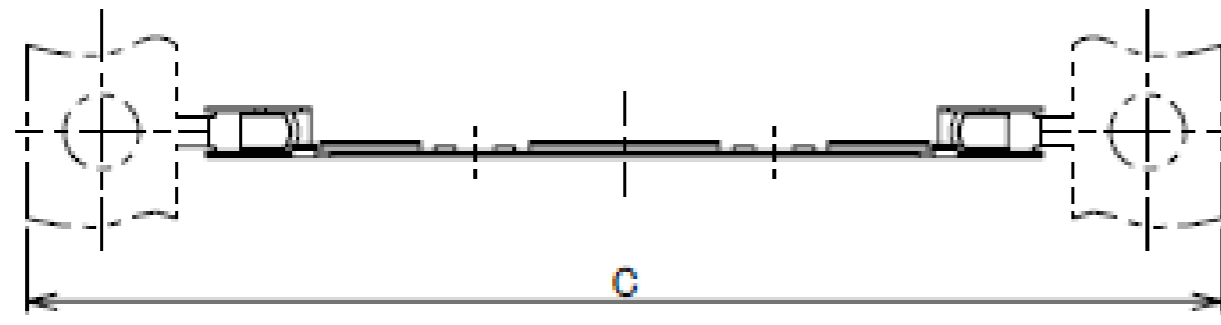
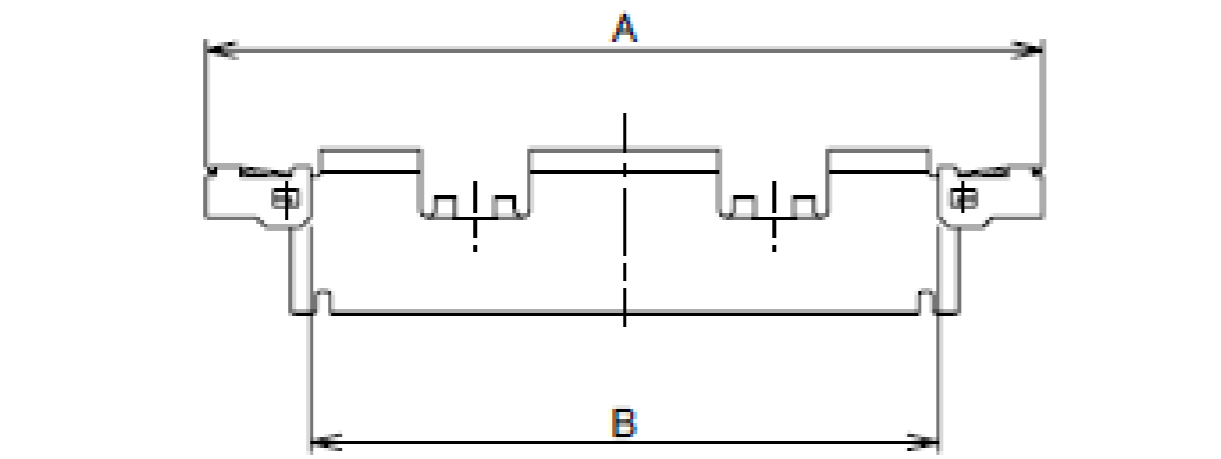
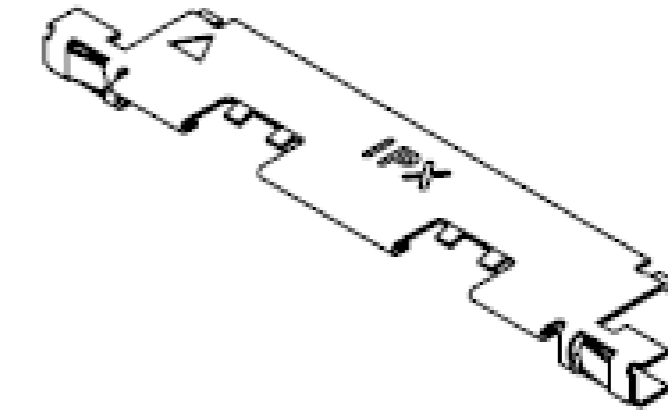
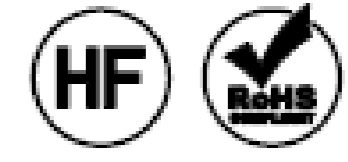

SECT. X-X
(S=10/1)

NO.	DISCRIPTION	MATERIAL	FINISH , REMARKS
1	SHELL A	SUS	Sn 1.00 μ m MIN. OVER Ni 0.50 μ m MIN.

Rev.21

Receptacle Assembly

Recommended P/N		20347-3**E-12R			
PART NO.	POS.	A	B	C	T
20347-310E-12R	10	8.40	3.60	8.80	2.60
20347-315E-12R	15	10.40	5.60	10.80	4.60
20347-320E-12R	20	12.40	7.60	12.80	6.60
20347-325E-12R	25	14.40	9.60	14.80	8.60
20347-330E-12R	30	16.40	11.60	16.80	10.60
20347-335E-12R	35	18.40	13.60	18.80	12.60
20347-340E-12R	40	20.40	15.60	20.80	14.60

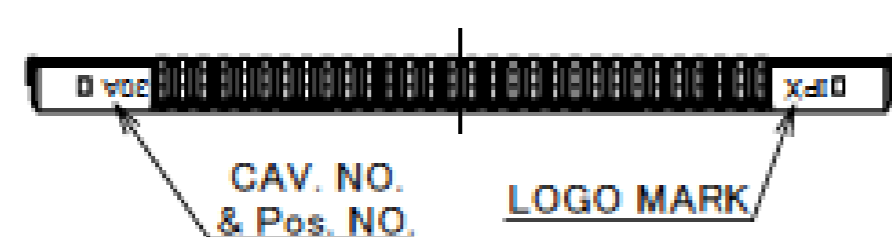
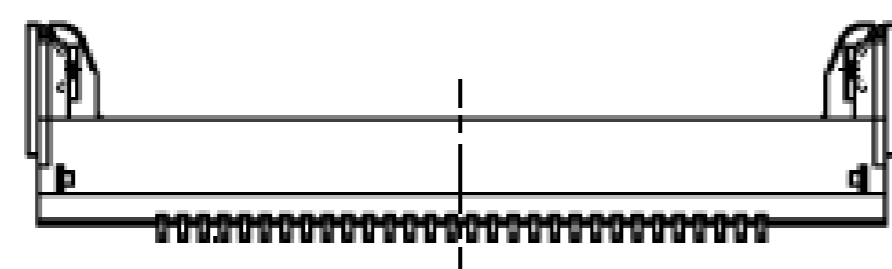
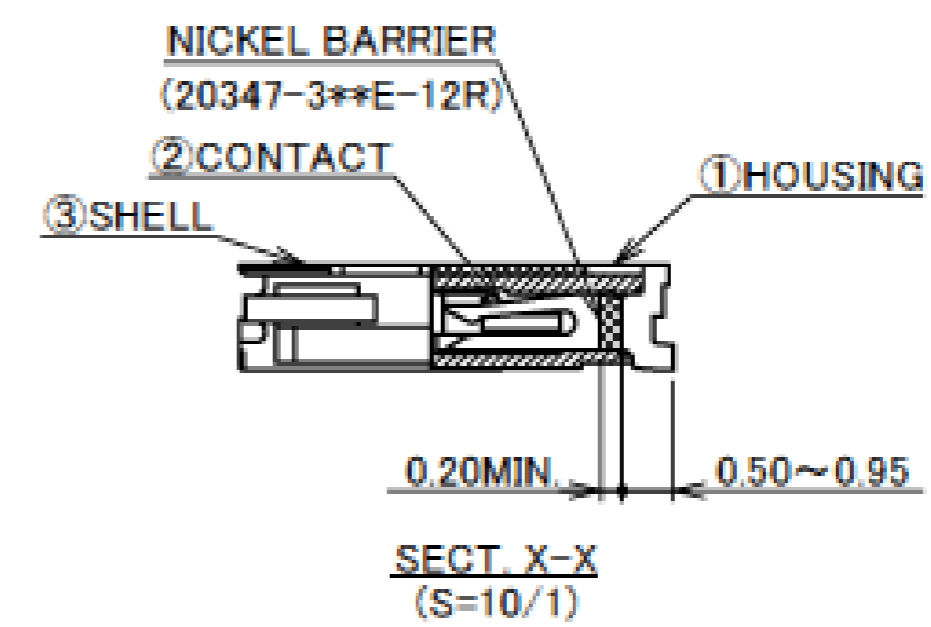
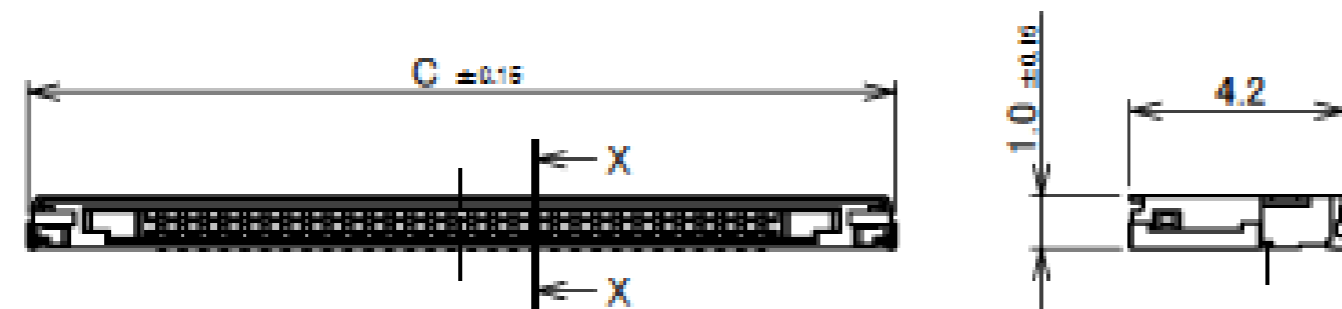
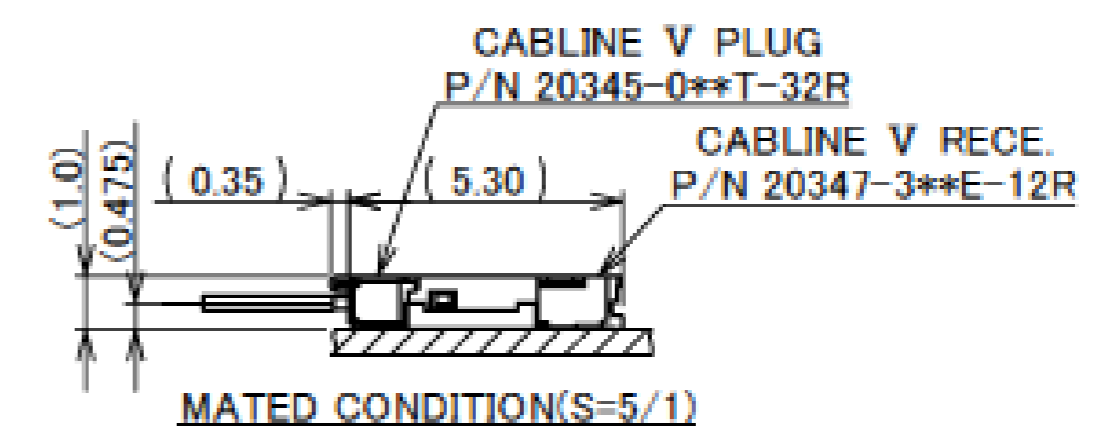
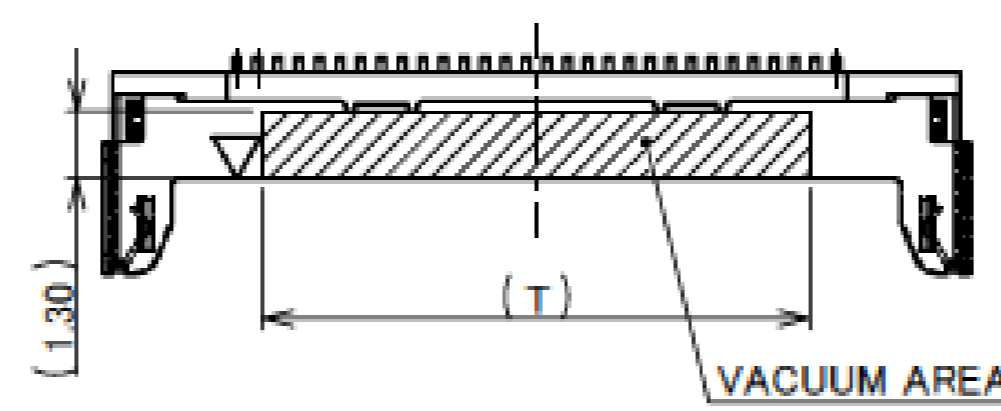
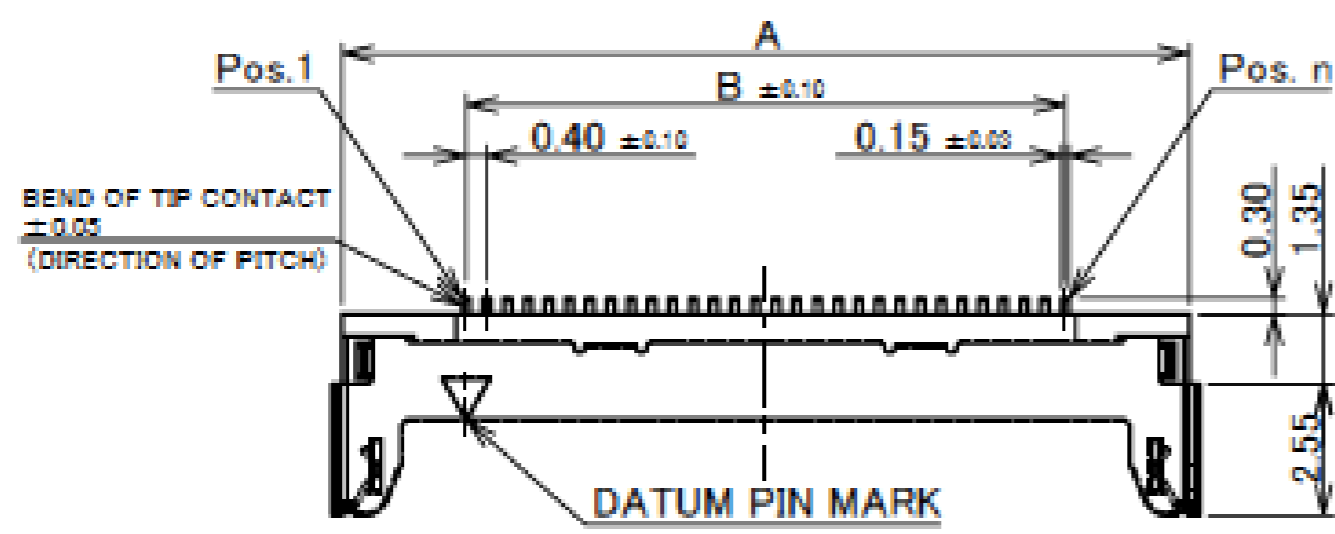

NO.	DISCRIPTION	MATERIAL	FINISH , REMARKS
3	SHELL	PHOSPHOR BRONZE	Sn 1.00 μ m MIN. OVER Ni 1.00 μ m MIN.
2	CONTACT	PHOSPHOR BRONZE	ALL OVER: Ni 1.00 μ m MIN. UNDER PLATING CONTACT AREA: Au 0.10 μ m MIN. SOLDERING AREA: Au 0.03 μ m MIN.
1	HOUSING	LCP	UL94V-0, BRACK

Rev.36

Receptacle Assembly

PART NO.	POS.	B	D	E
20347-310E-12R	10	3.60	8.10	9.40
20347-315E-12R	15	5.60	10.10	11.40
20347-320E-12R	20	7.60	12.10	13.40
20347-325E-12R	25	9.60	14.10	15.40
20347-330E-12R	30	11.60	16.10	17.40
20347-335E-12R	35	13.60	18.10	19.40
20347-340E-12R	40	15.60	20.10	21.40

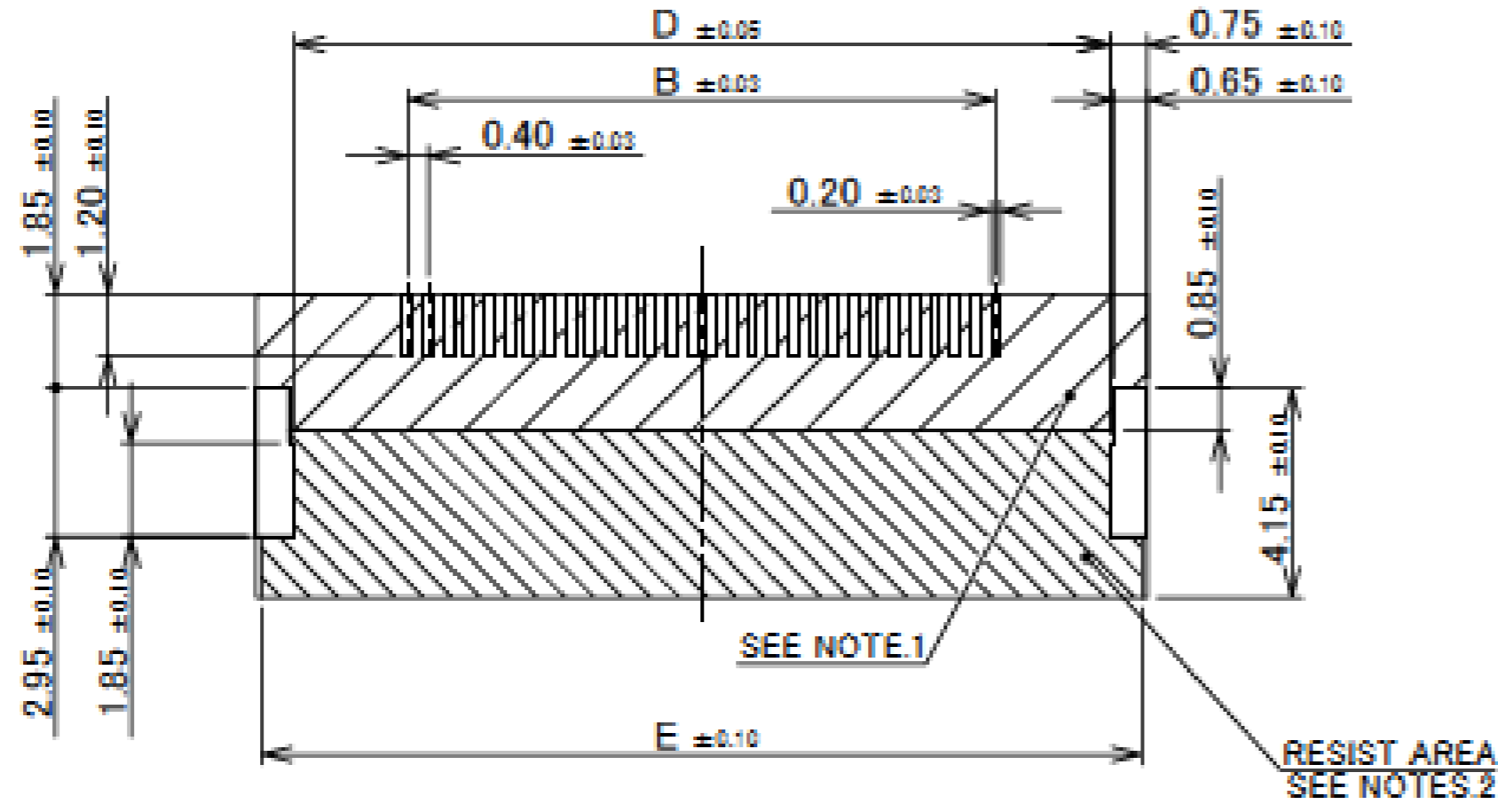

RECOMMENDED FOOT PRINT PATTERN & METALMASK LAYOUT
 RECOMMENDED METALMASK THICKNESS : $t=0.12$

- NOTES.
 1. DO NOT MOUNT ANOTHER COMPONENTS IN THIS AREA.
 2. SOLDER RESIST MUST BE APPLIED TO THIS AREA.

Rev.36

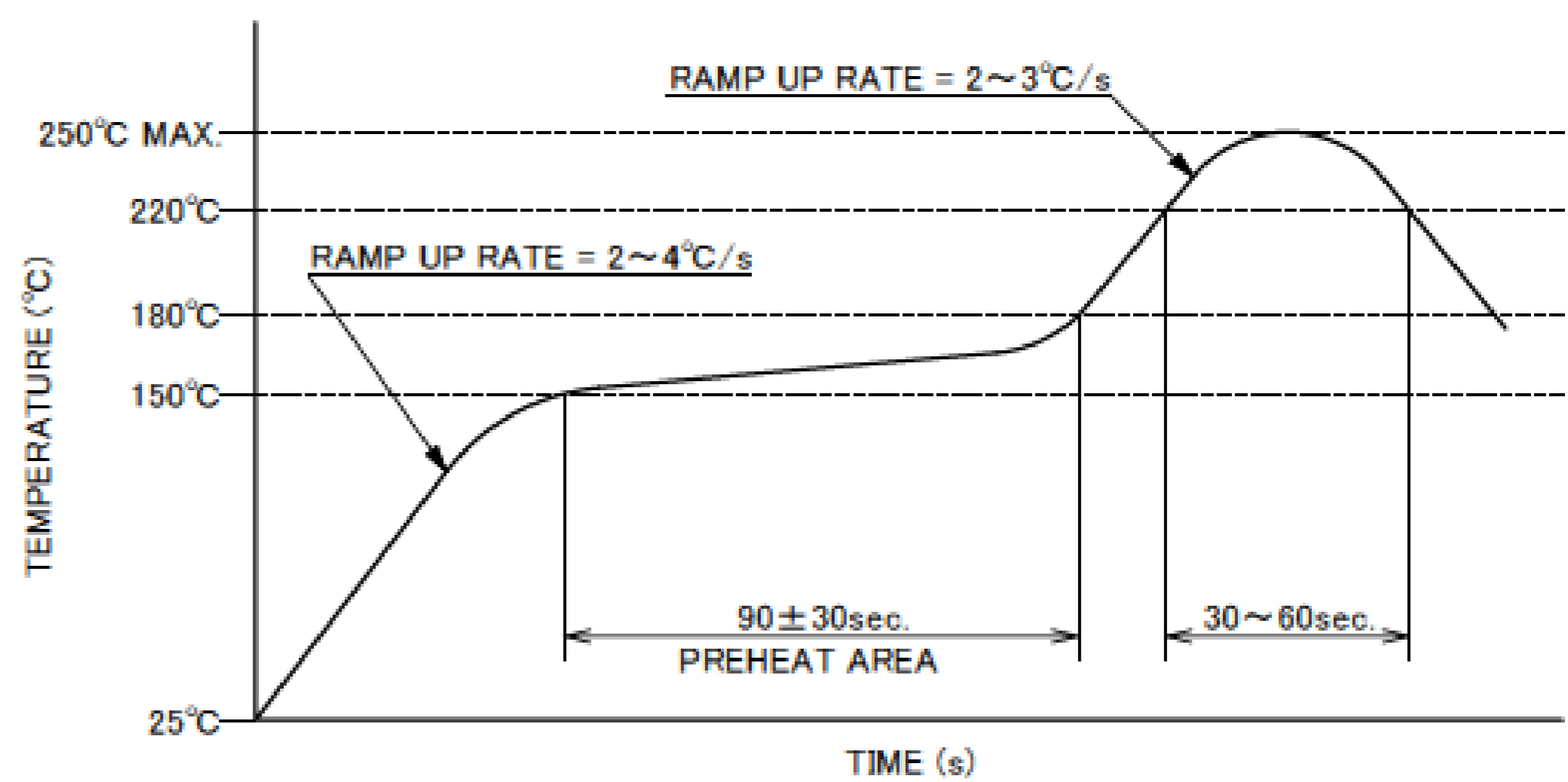
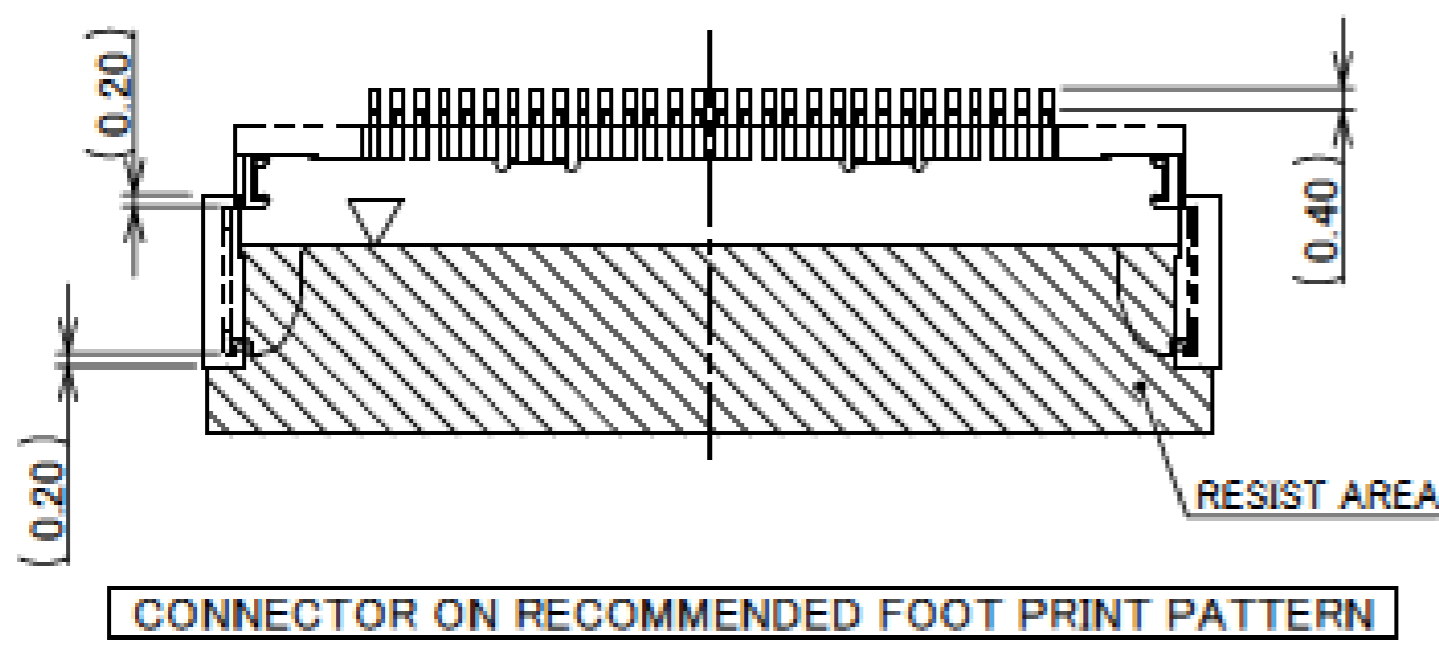

REFLOW TEMPERATURE PROFILE
 SENJU METAL INDUSTRY CO., LTD. : M705-SHF(Sn96.5 Ag3.0 Cu0.5)

Rev.36

Receptacle Assembly

ITEMS	SPECIFICATION
APPLICABLE CABLE	MICRO-COAXIAL CABLE : AWG# 44,42,40 DISCRETE WIRE : AWG# 36 TWINAX : AWG# 40
RATING VOLTAGE	100V AC (PER CONTACT PIN)
RATING AMPERAGE (FOR CONTACT)	0.1A AC/DC [AWG#44] PER CONTACT PIN / UP TO 40 CONTACTS 0.24A AC/DC [AWG#42] PER CONTACT PIN / UP TO 40 CONTACTS 0.3A AC/DC [AWG#40] PER CONTACT PIN / UP TO 40 CONTACTS 0.8A AC/DC [AWG#36] PER CONTACT PIN / UP TO 12 CONTACTS ※ TESTING BY A REAL MACHINE IS RECOMMENDED BECAUSE TEMPERATURE RISE MAY AFFECTED BY ACTUAL SITUATION.
OPERATING TEMPERATURE	233~358K(-40°C~+85°C)
OPERATING HUMIDITY	85% MAX.(NON-CONDENSING)
CONTACT RESISTANCE	INITIAL : 235mohm MAX.(AWG#36) / AFTER TEST : \triangleleft40mohm MAX. 560mohm MAX.(AWG#40) 650mohm MAX.(AWG#42) 1040mohm MAX.(AWG#44)
GROUND SHELL RESISTANCE	INITIAL : 50mohm MAX. / AFTER TEST : \triangleleft40mohm MAX.
INSULATION RESISTANCE	INITIAL : 1000Mohm MIN. / AFTER TEST : 500Mohm MIN.
DIELECTRIC WITHSTANDING VOLTAGE	AC250V 1min
DURABILITY	30 CYCLES
MATING FORCE (INITIAL / AFTER TEST)	10P : 20.0N MAX. 15P : 22.5N MAX. 20P : 25.0N MAX. 25P : 27.5N MAX. 30P : 30.0N MAX. 35P : 32.5N MAX. 40P : 35.0N MAX.
UNMATING FORCE (INITIAL / AFTER TEST)	10P : 4.0N MIN. 15P : 5.0N MIN. 20P : 5.5N MIN. 25P : 6.0N MIN. 30P : 7.0N MIN. 35P : 8.0N MIN. 40P : 8.5N MIN.
CABLE RETENTION FORCE	10P : 4.90N MIN. 15P : 7.35N MIN. 20P : 9.80N MIN. 25P : 12.25N MIN. 30P : 14.70N MIN. 35P : 17.15N MIN. 40P : 19.60N MIN.
COPLANARITY	0.10 MAX.
PRODUCT SPECIFICATION	P/N 20347-3**E-12R : PRS-1461
TEST REPORT	P/N 20347-3**E-12R : TR-08068
PACKING STANDARD	300-308
INSTRUCTION MANUAL	HIM-03005
ASSEMBLY MANUAL	ASM-03002
APPEARANCE CRITERIA NO.	QLS-A***

Rev.36

Custom Connectors Available

 RF Connector

MHF® series



 CABLINE® series
Micro-coaxial/Twinax/
Discrete Wire Connector

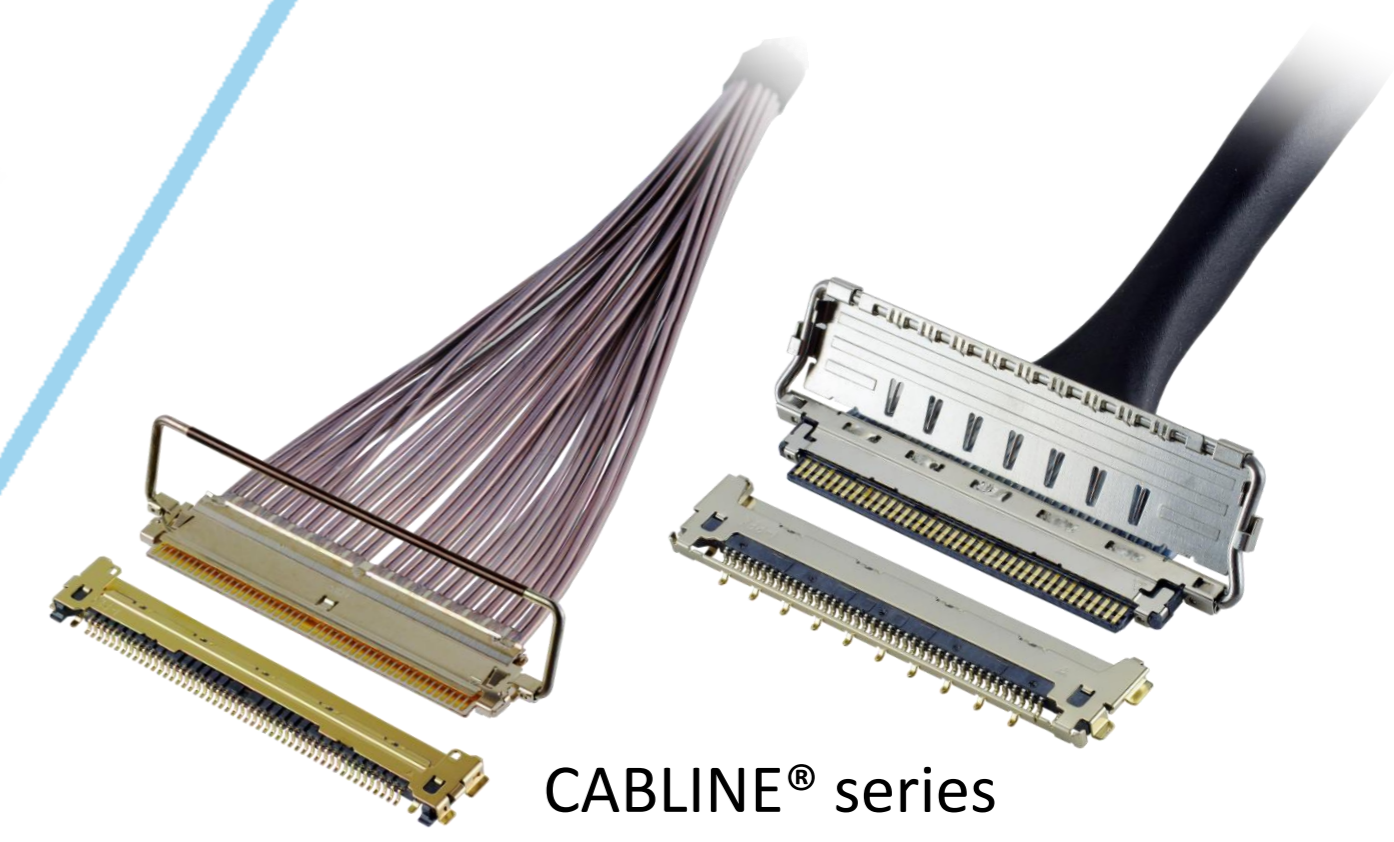

 Optical Module

LIGHTPASS® series



NOVASTACK® series

 Board-to-Board Connector

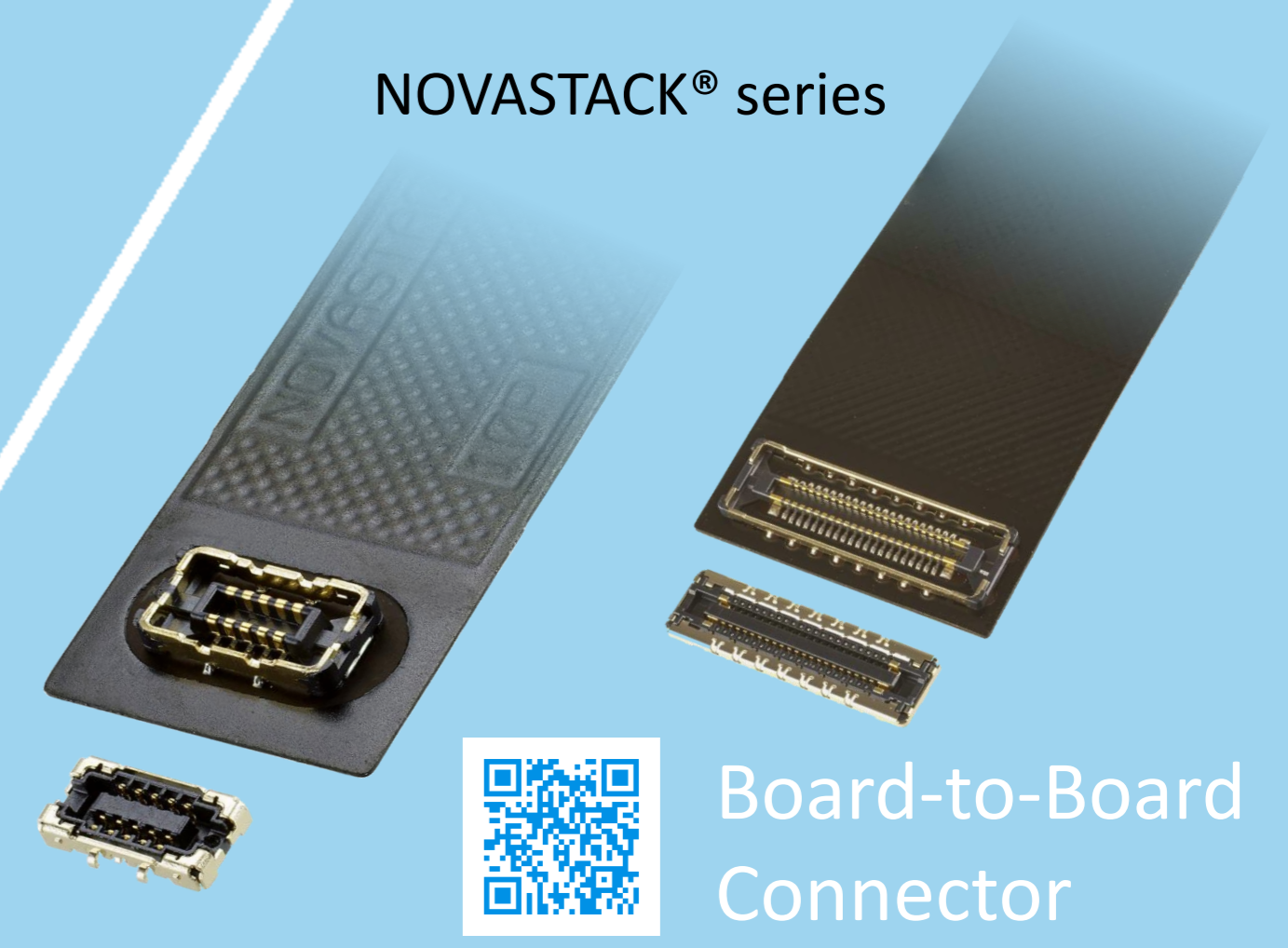

 Power Connector/
Terminal

AP series

ISH® series



MINIFLEX® series

EVAFLEX® series

 FPC FFC Connector



Inquiry



MINIDOCK® series

 I/O Connector

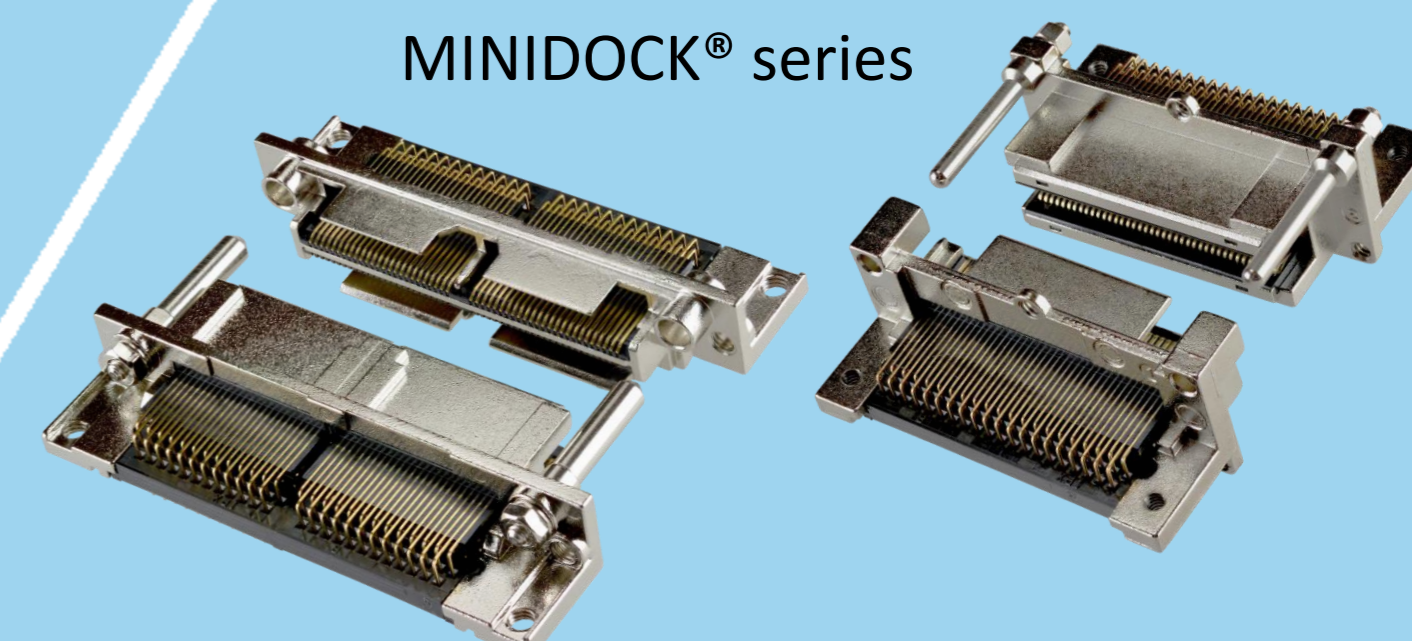

I-PEX, MHF, CABLINE, LIGHTPASS, NOVASTACK, ISH, IARPB, MINIFLEX, EVAFLEX, MINIDOCKS and ZenShield are registered trademarks of I-PEX Inc. Please note that the contents in the catalog might be changed without prior notification. I-PEX Inc. assumes no responsibility for any inaccuracies or obligation to update information on these documents. Please be sure to read and understand the latest "Precautions for Use" and "Instruction Manual" before you use our products. We shall not be responsible for any defects, damages or troubles in case you use our products without following the precautions for use. Please feel free to contact our sales representatives when you use our products for any applications that require very high reliability and safety, or that relate to human life (ex. nuclear power control, aerospace, transportation, medical equipment, safety equipment etc.).

Contact your sales representative or more detailed information.

www.i-pex.com



I-PEX

© I-PEX Inc. 2024
All rights reserved