

CABLIN®-VS II

全屏蔽·自帶機械式鎖扣·適用於高速數據傳輸 (20Gbps/lane), 0.5 mm間距·水平插拔式極細同軸線連接器

Product Specifications:

Mating type	Horizontal	
Board Pitch (mm)	0.5	
Wiping Length (mm)	0.54	
Mated size (mm)	Height	1.2 max. with cover
	Width	Formula: 6.85 + (0.5*p)
	Depth	6.70
Pin Counts	Range	Up to 55
	Available	20, 30, 40

Applicable Cable Size:

Maximum O.D. (mm)	0.5
Micro-Coaxial for Signal (AWG)	45 ohm: #36 or smaller 50 ohm: #38 or smaller
Twinax (AWG)	#40
Discrete (AWG)	#32 or smaller

Applicable Standards (Reference Only):

USB4 Gen3/Thunderbolt 4(20 Gbps/lane), PCIe Gen 4 (16 GT/s), USB 3.1 Gen 2 (10 Gbps), eDP HBR 3 (8.1 Gbps)

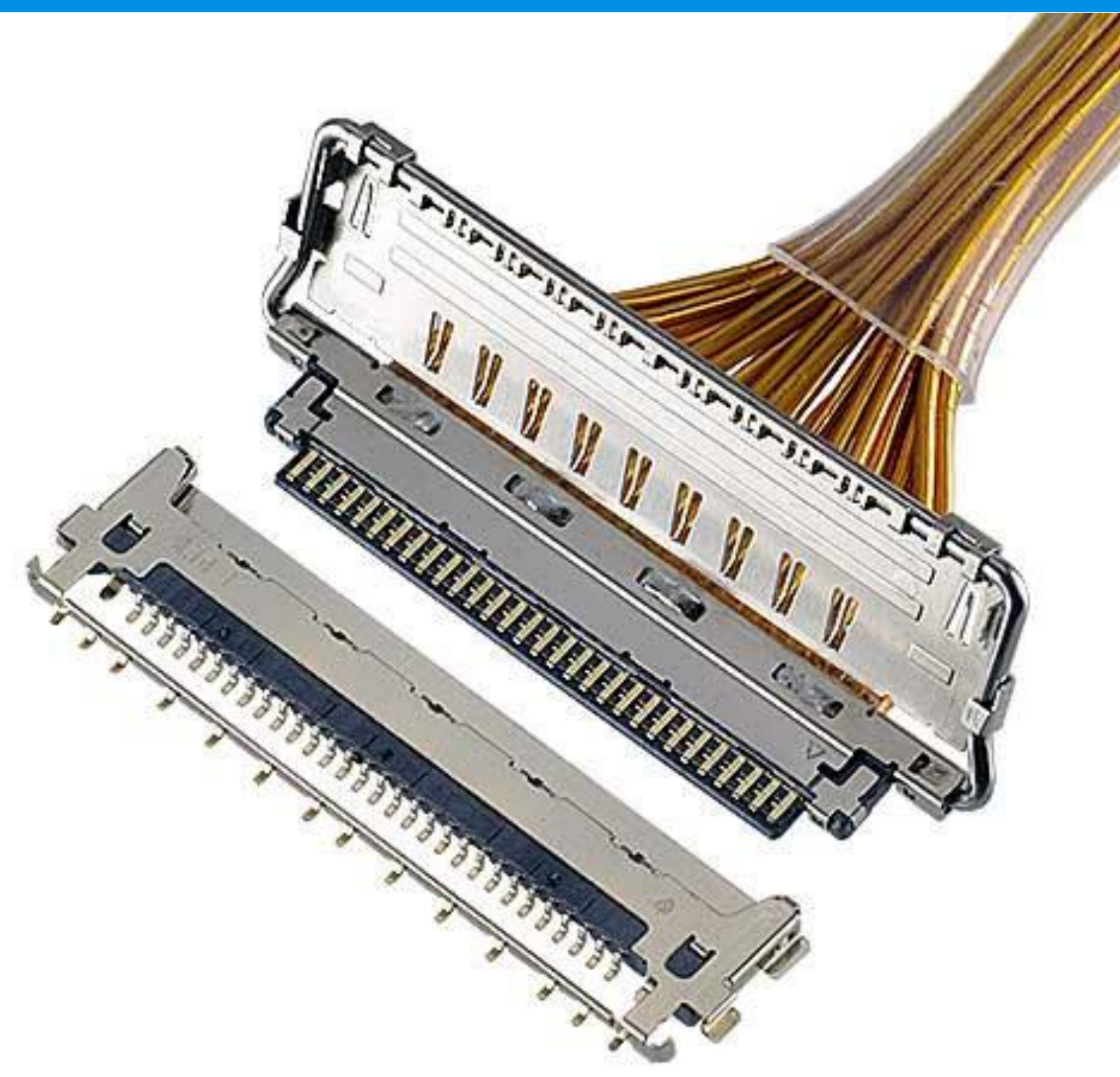

*若有規格外 Pin數需求,請與當地負責業務窗口聯繫。

▶ ZenShield® 的全屏蔽和多點接地設計，有效防止EMI外洩

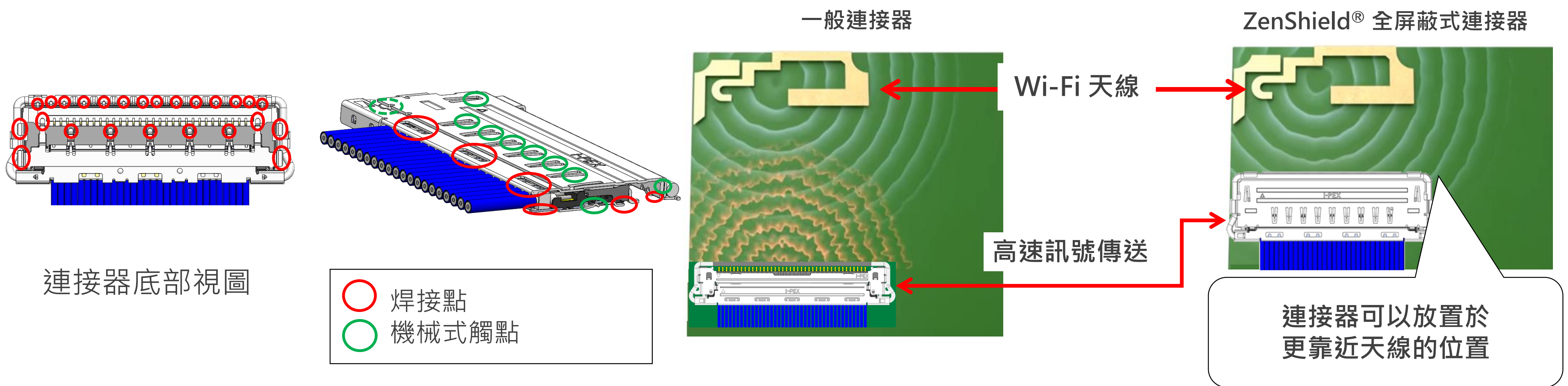

▶ 機械式鎖扣罩防止連接器不完全嵌合及脫落

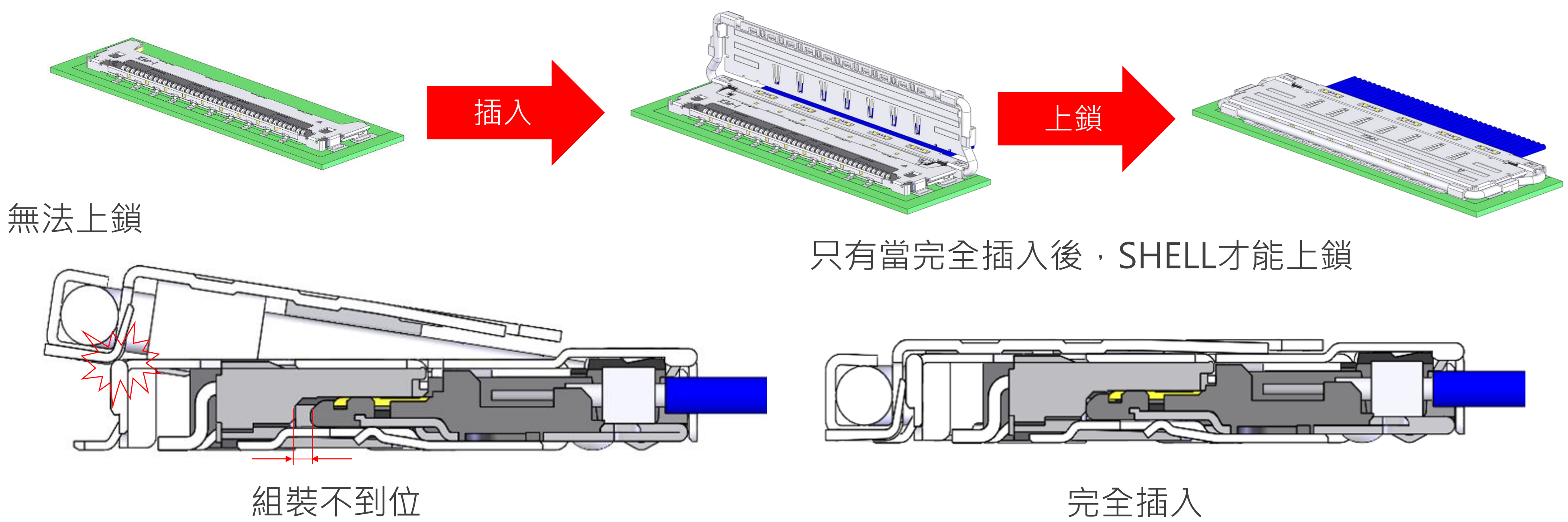

▶ 高速率傳輸, USB4 Gen3/Thunderbolt 4(20Gbps/lane)應用的理想之選

USB4 Gen3/Thunderbolt 4 (20Gbps/lane)

眼圖 (差動傳輸)
 比特率: 20Gbps
 上升時間: 30ps (10-90%)
 輸入電壓: 800mVp-p

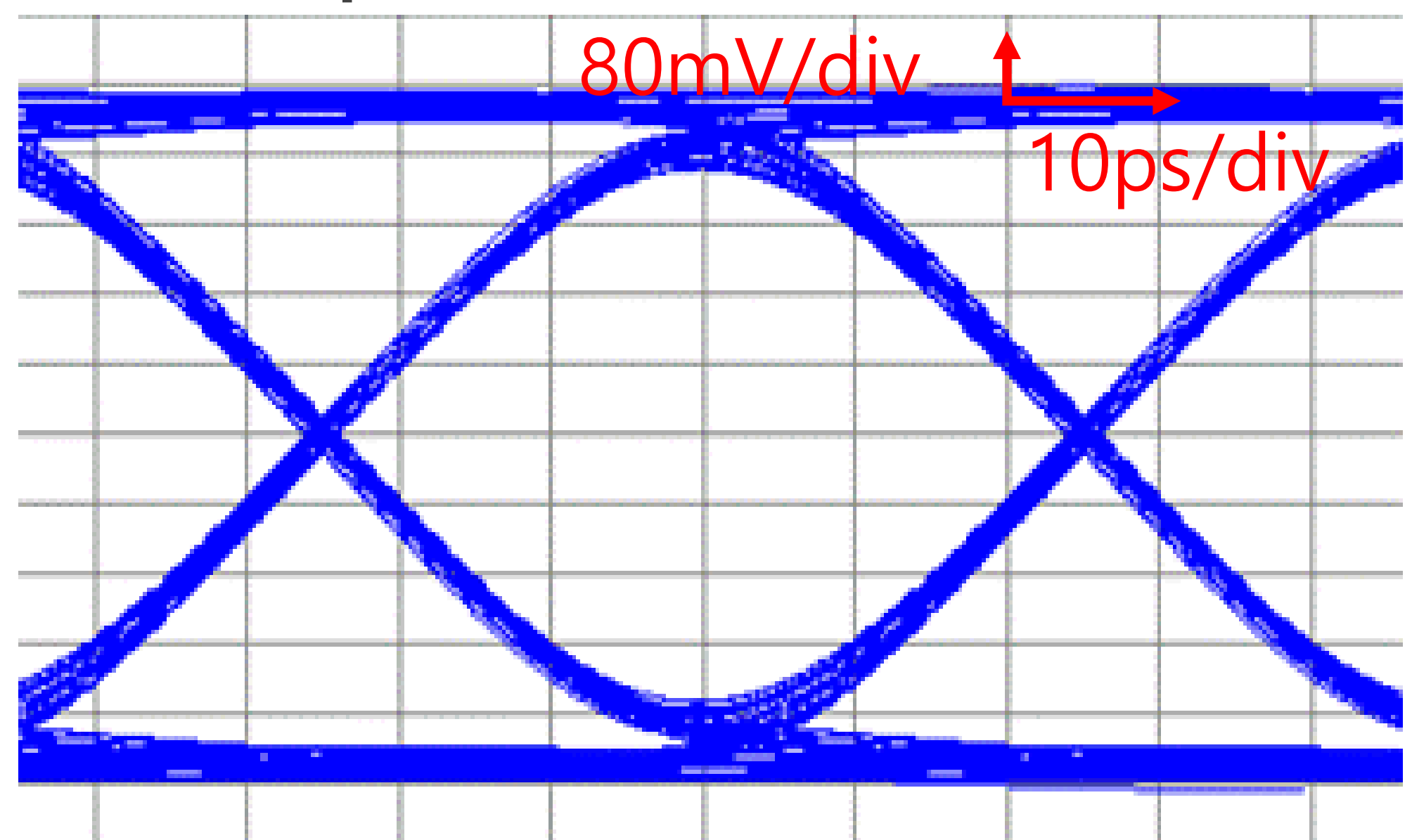

*詳細規格內容請與當地負責業務窗口聯繫

Component Parts Details

Component Parts

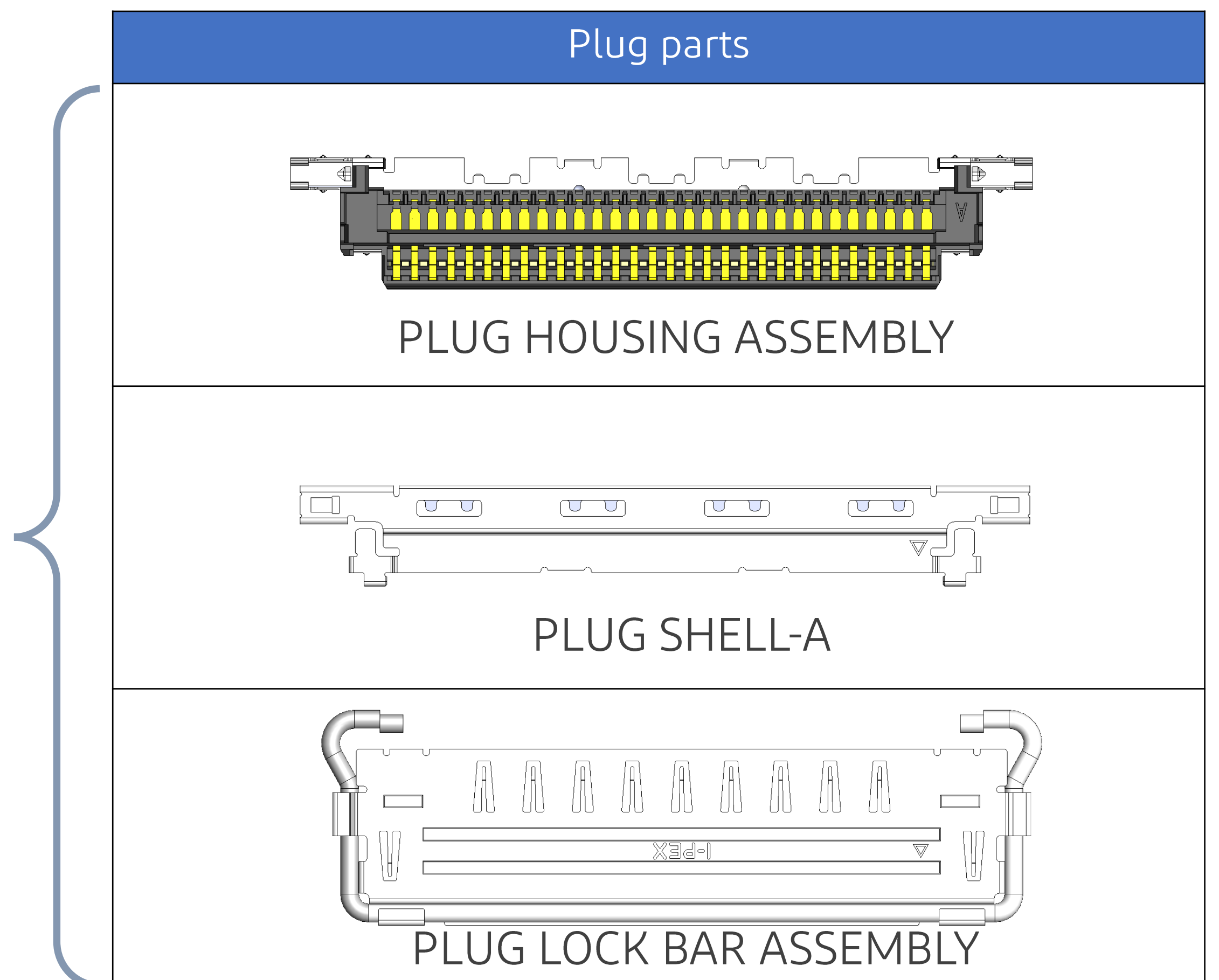
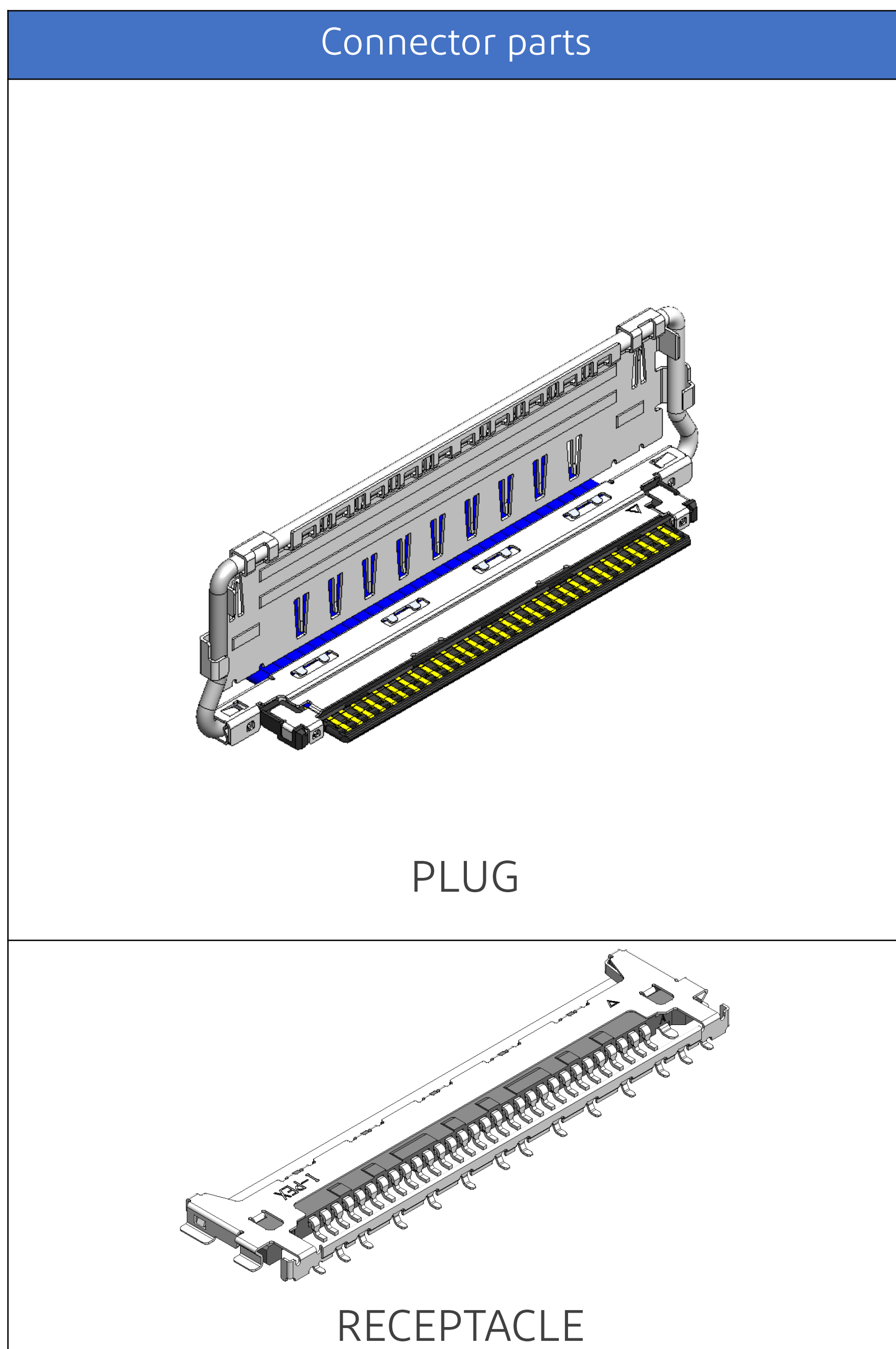

Plug for Cable Assembly

Recommended P/N		20846-0**T-01				
PART NO.	Pos.	A	B	C	D	E
20846-020T-0#	20	15.30	9.50	10.30	12.56	16.85
20846-030T-0#	30	20.30	14.50	15.30	17.56	21.85
20846-040T-0#	40	25.40	19.50	20.30	22.56	26.85

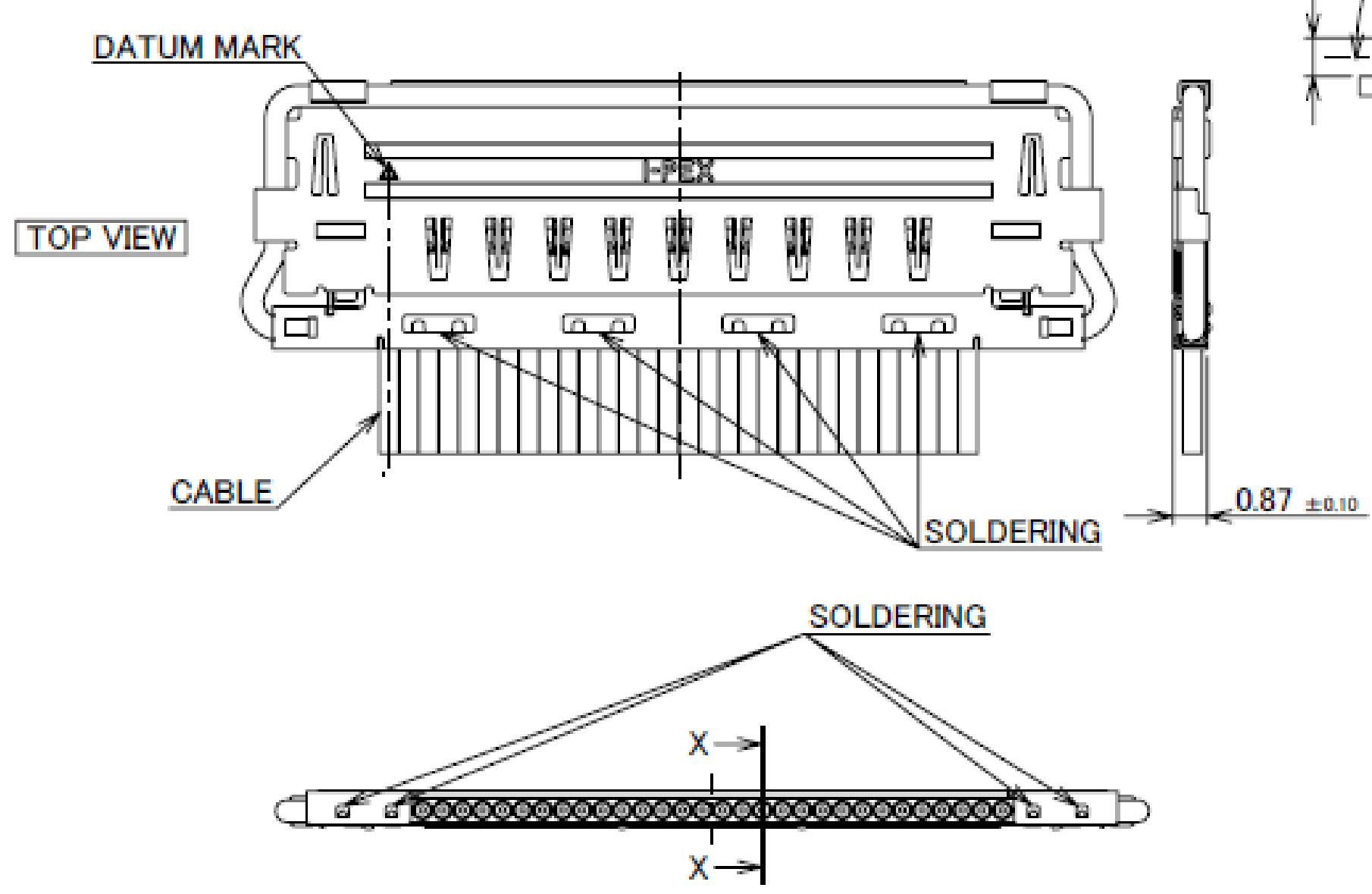
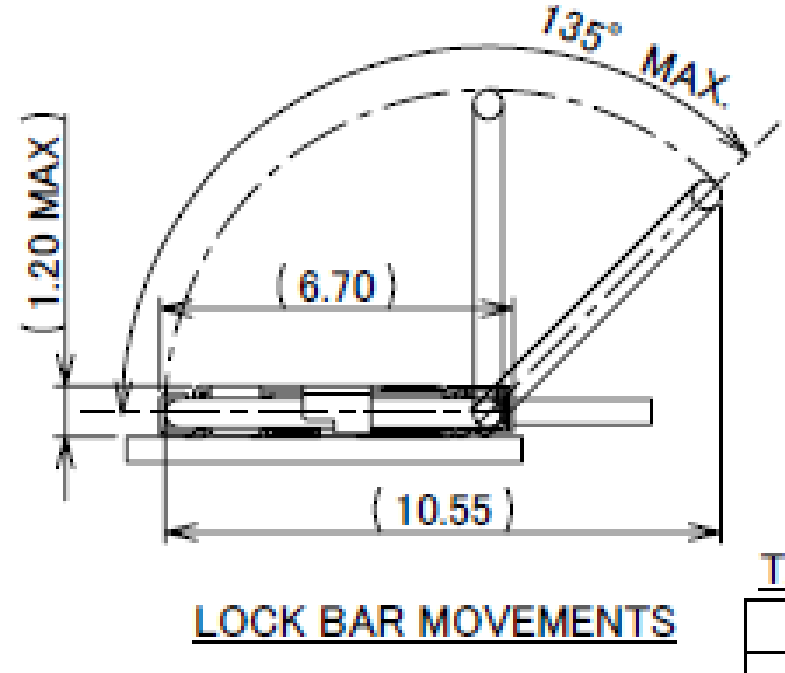
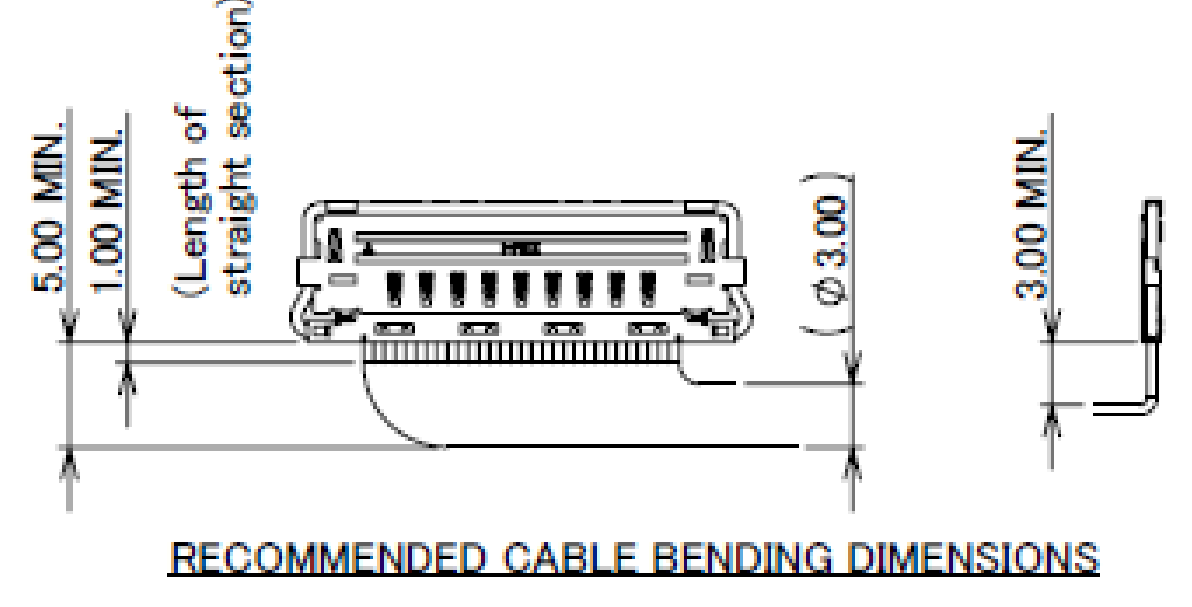
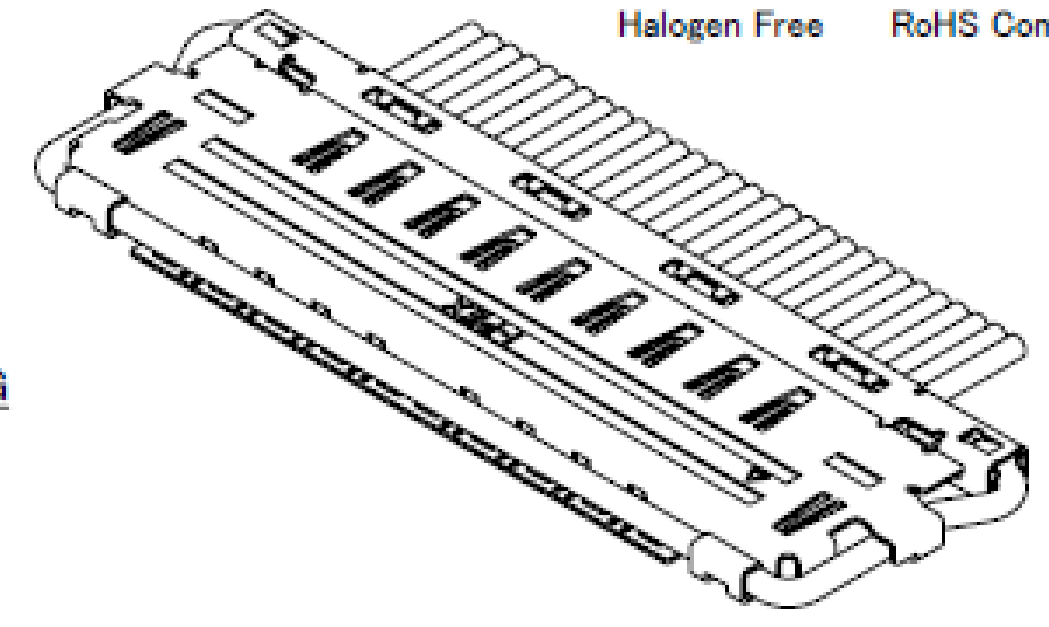
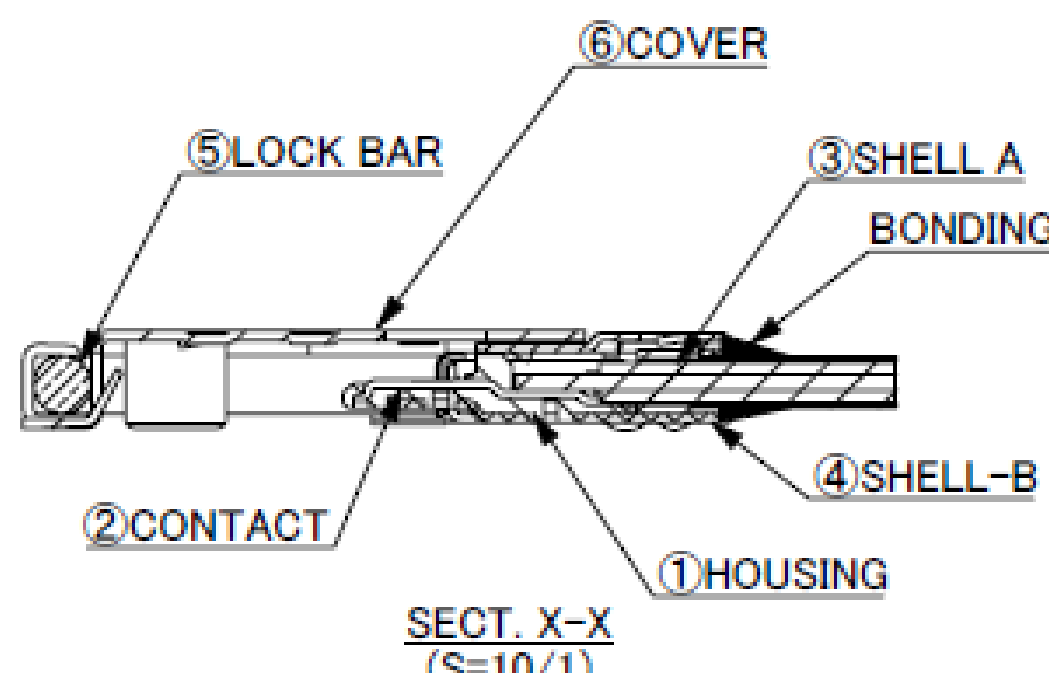
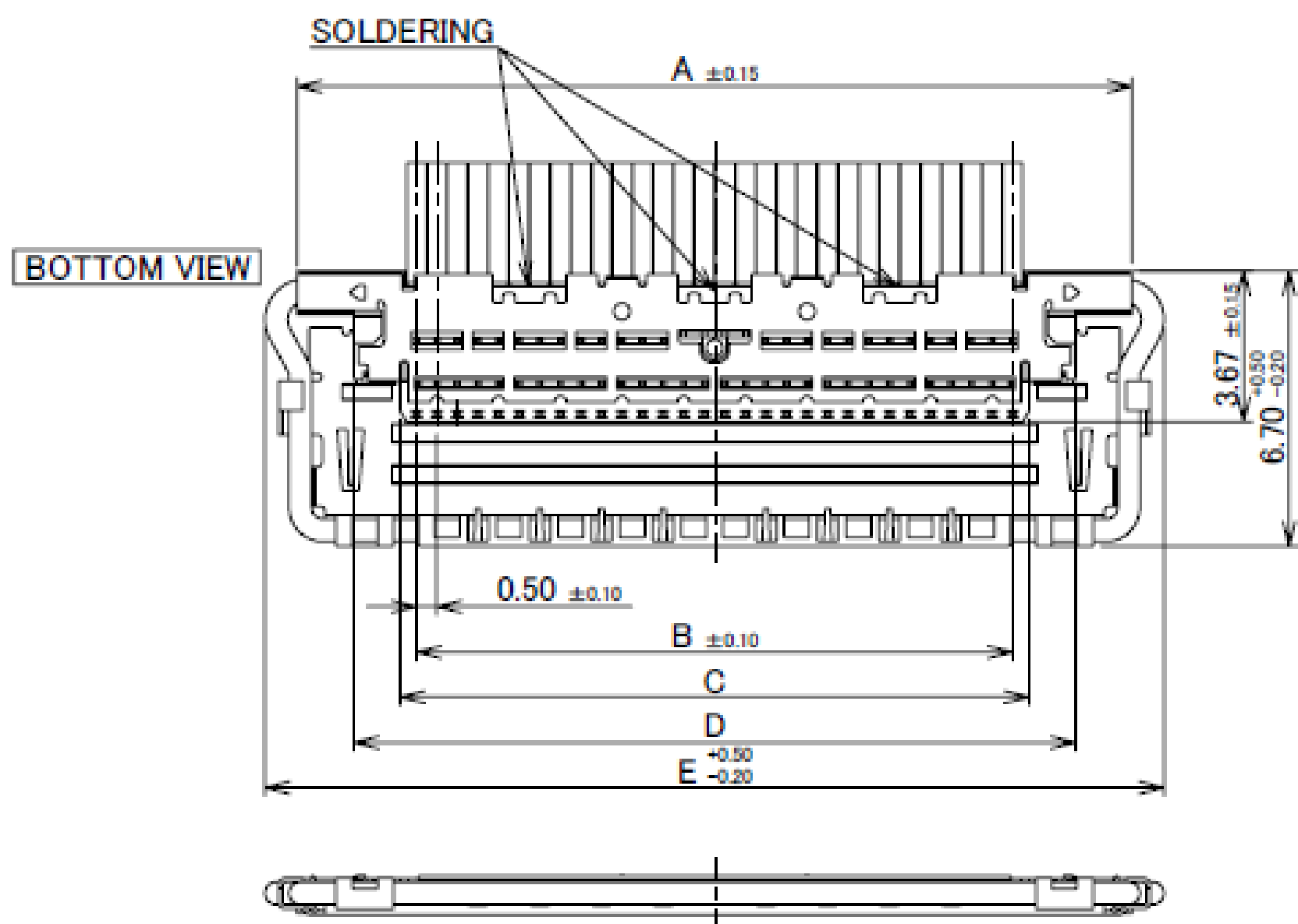

TABLE 1

PART NO.	CONTACT FINISH
20846-0**T-01	CONTACT & SOLDERING AREA : Au 0.03 μ m MIN. OVER Ni 1.00 μ m MIN.
20846-0**T-02	CONTACT AREA : Au 0.38 μ m MIN. OVER Ni 1.27 μ m MIN. SOLDERING AREA : Au 0.03 μ m MIN. OVER Ni 1.00 μ m MIN.

NO.	DISCRIPTION	MATERIAL	FINISH, REMARKS
6	COVER	PHOSPHOR BRONZE	ALL OVER Ni 1.00 μ m MIN.
5	LOCK BAR	SUS	-
4	SHELL-B	PHOSPHOR BRONZE	PARTIAL Au 0.003 μ m MIN. OVER Ni 1.00 μ m MIN.
3	SHELL-A	PHOSPHOR BRONZE	PARTIAL Au 0.003 μ m MIN. OVER Ni 1.00 μ m MIN.
2	CONTACT	PHOSPHOR BRONZE	SEE TABLE 1
1	HOUSING	LCP	UL94V-0, BLACK

Rev.11

PART NO.	Pos.	B	G
20846-020T-0#	20	9.50	10.70
20846-030T-0#	30	14.50	15.70
20846-040T-0#	40	19.50	20.70

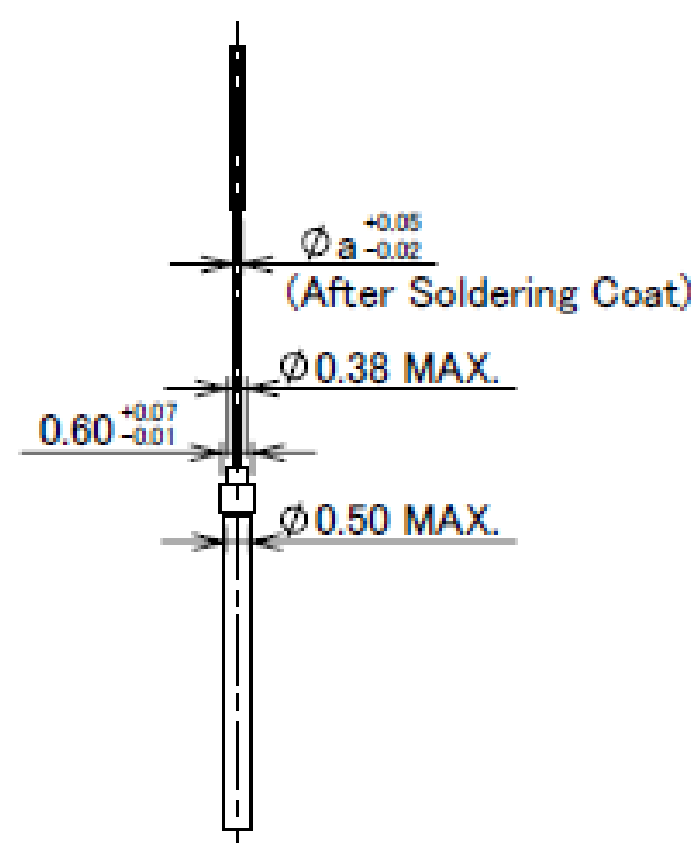
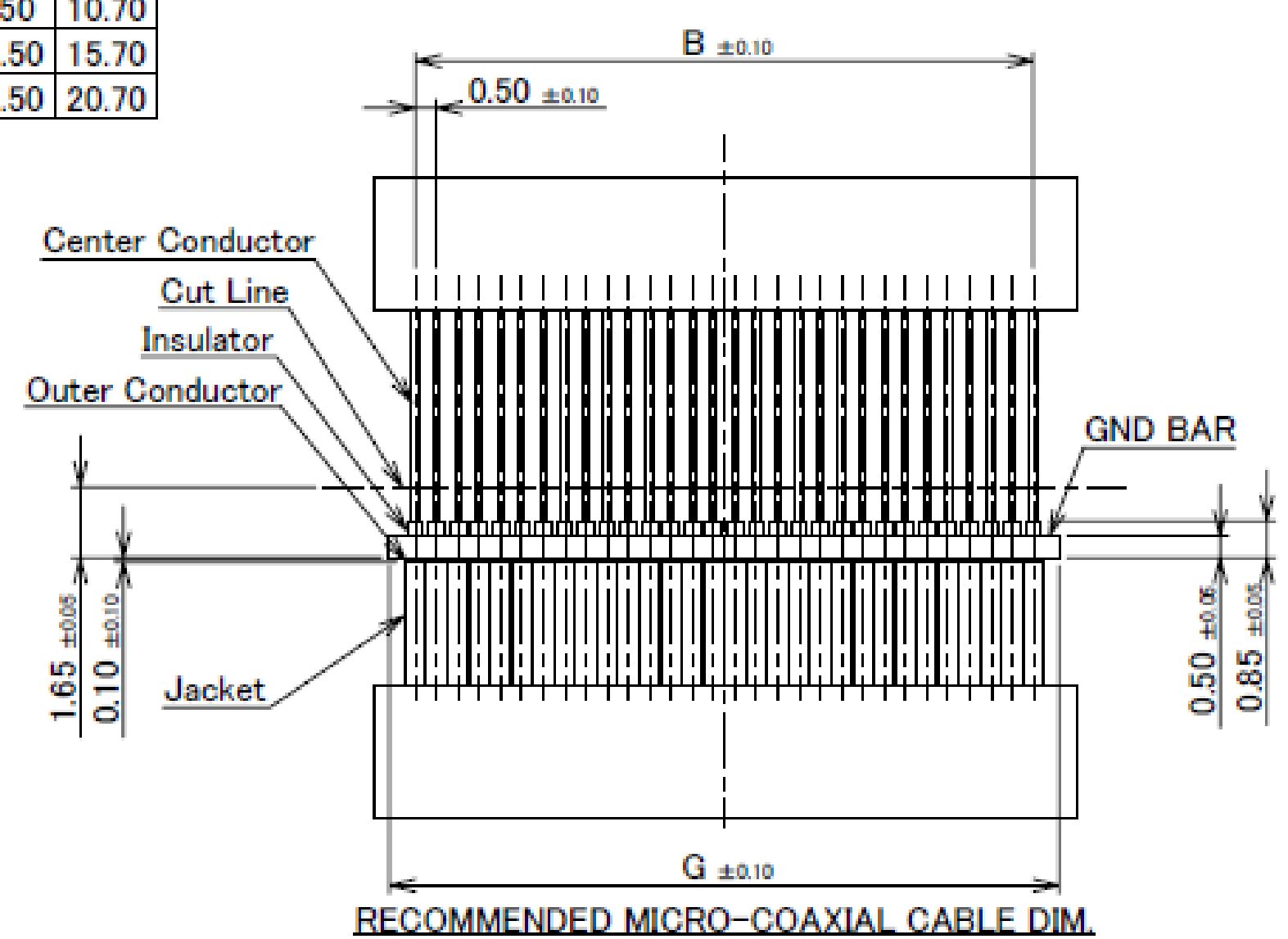

MICRO-COAXIAL CABLE DIMENSION

AWG#	a
#36	0.15
#38	0.12
#40	0.09
#42	0.075
#44	0.063

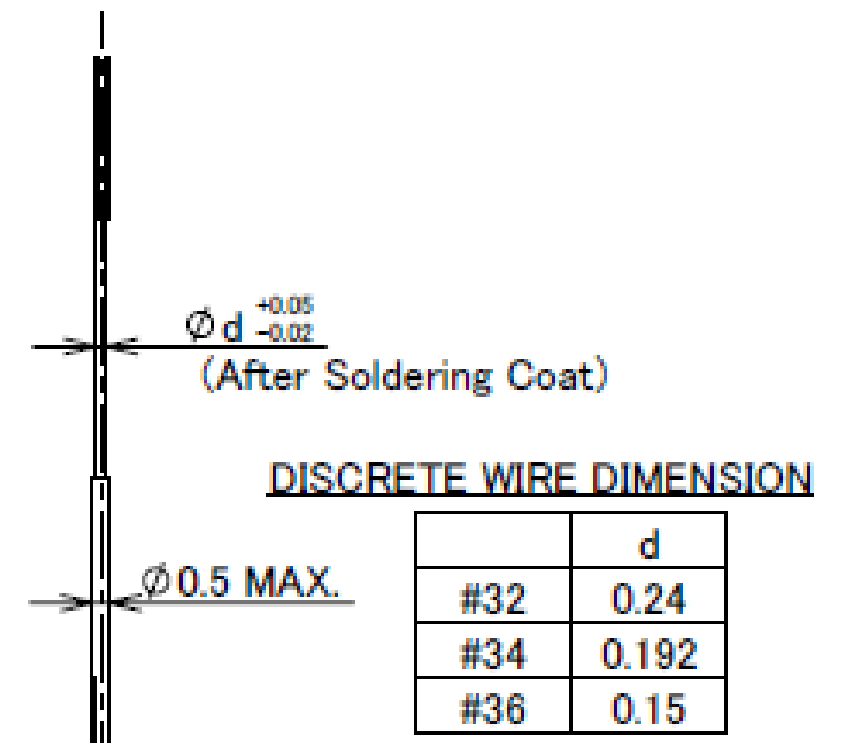
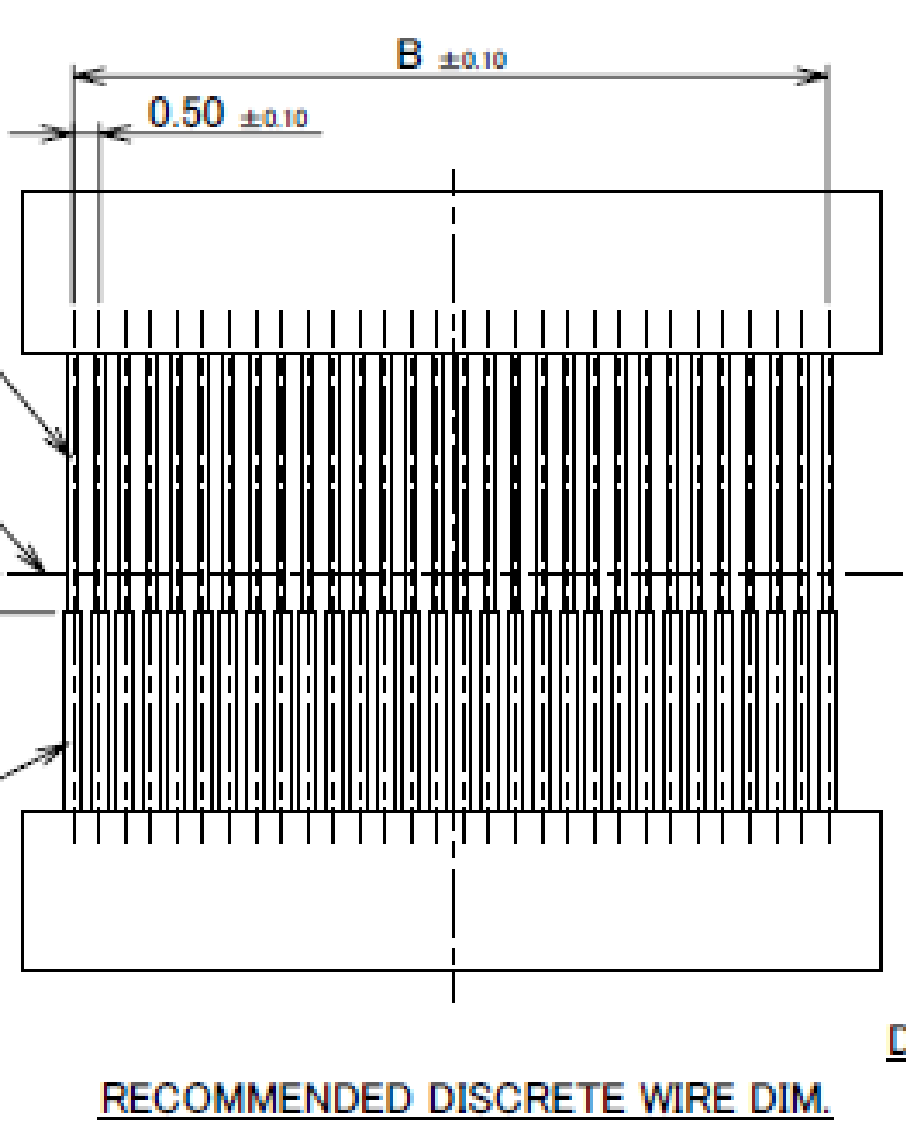
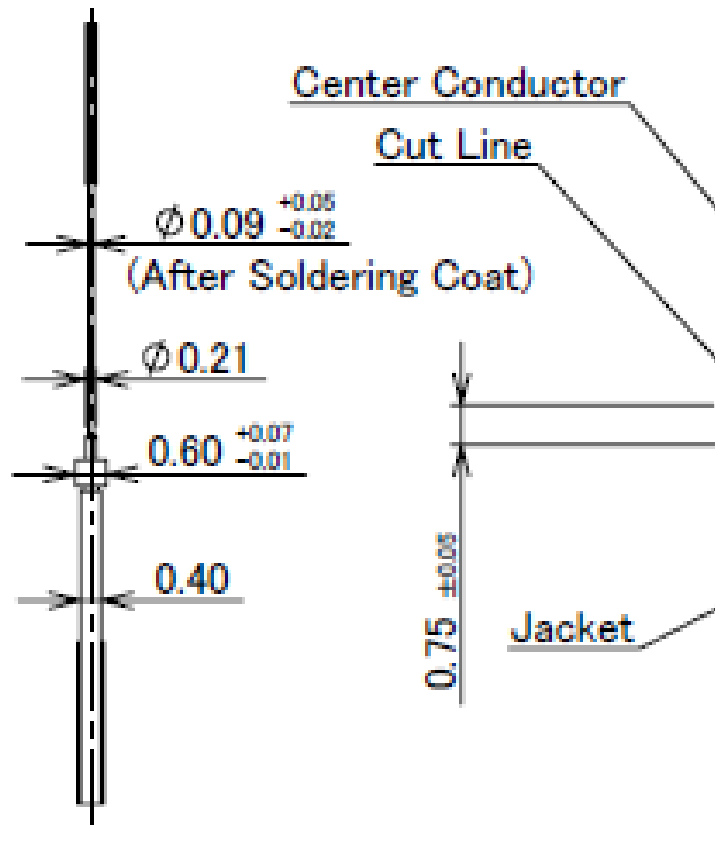
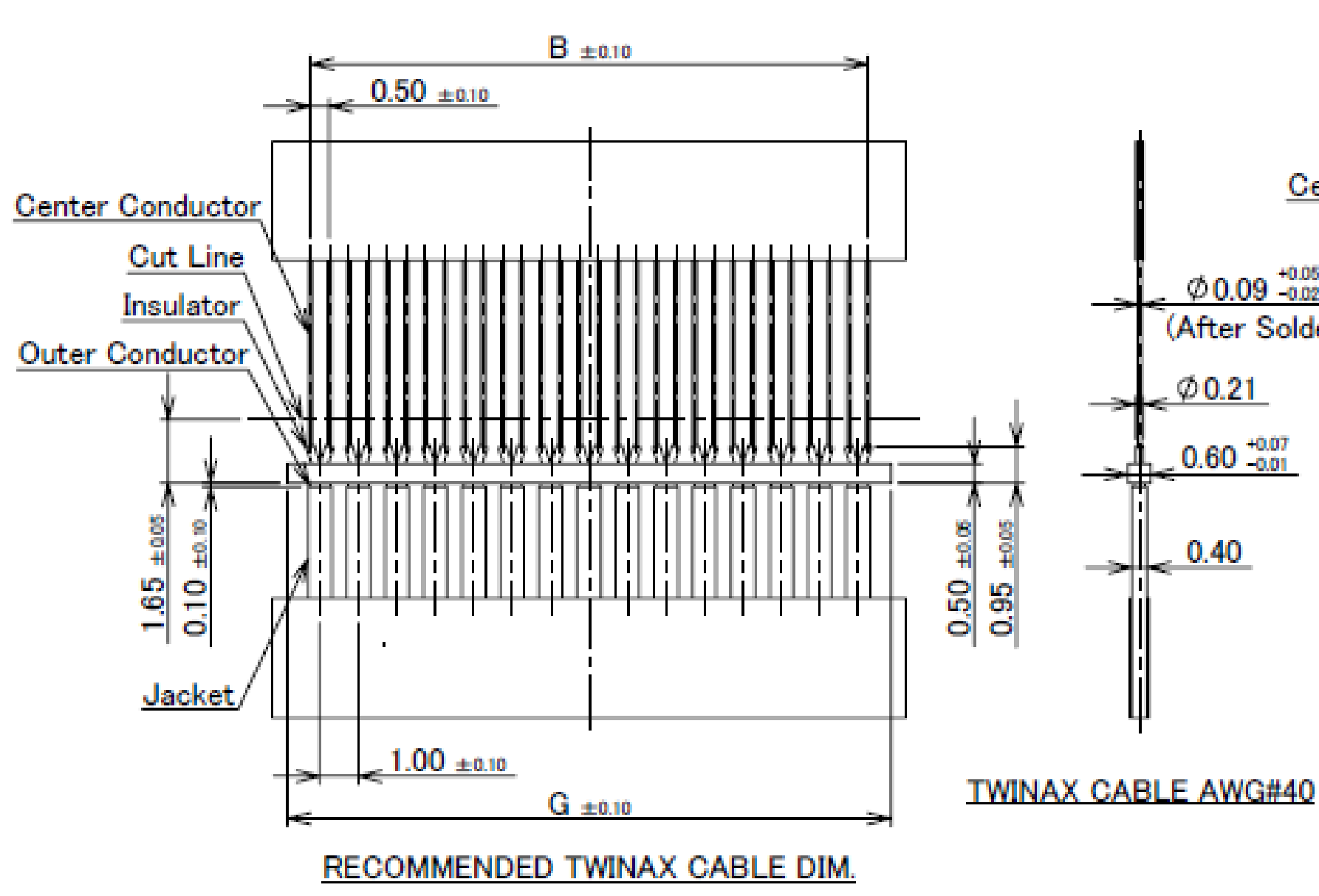

DISCRETE WIRE DIMENSION

AWG#	d
#32	0.24
#34	0.192
#36	0.15

Rev.11

Plug Housing Assembly

Recommended P/N 20847-0**T-01

PART NO.	Pos.	A	B	C	D	E	F	G	H	J	K
20847-020T-0#	20	-	-	5.00	15.30	11.00	10.55	10.20	9.50	10.30	12.56
20847-030T-0#	30	4.50	4.50	9.00	20.30	16.00	15.55	15.20	14.50	15.30	17.56
20847-040T-0#	40	9.00	4.50	13.50	25.40	21.00	20.55	20.20	19.50	20.30	22.56

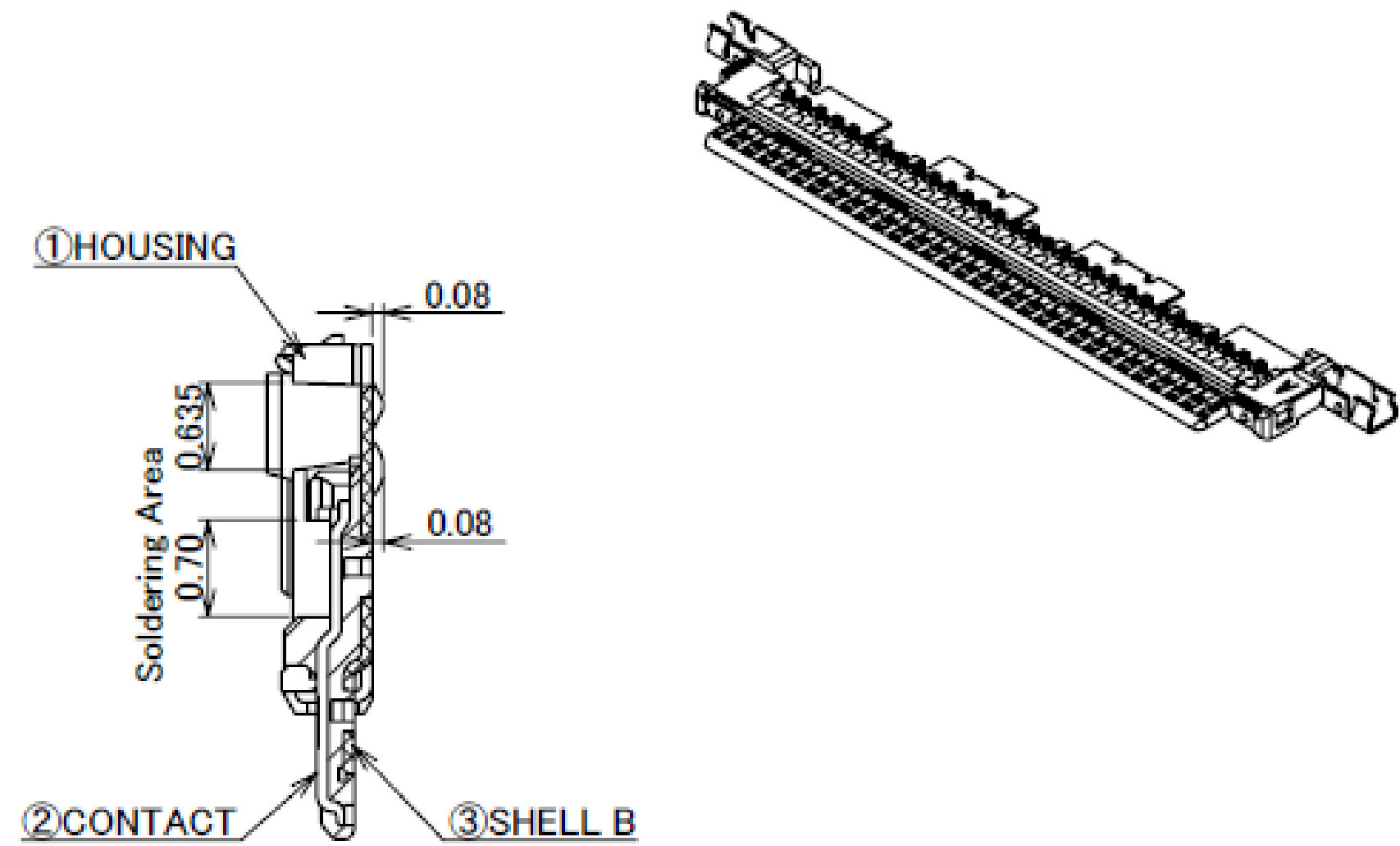
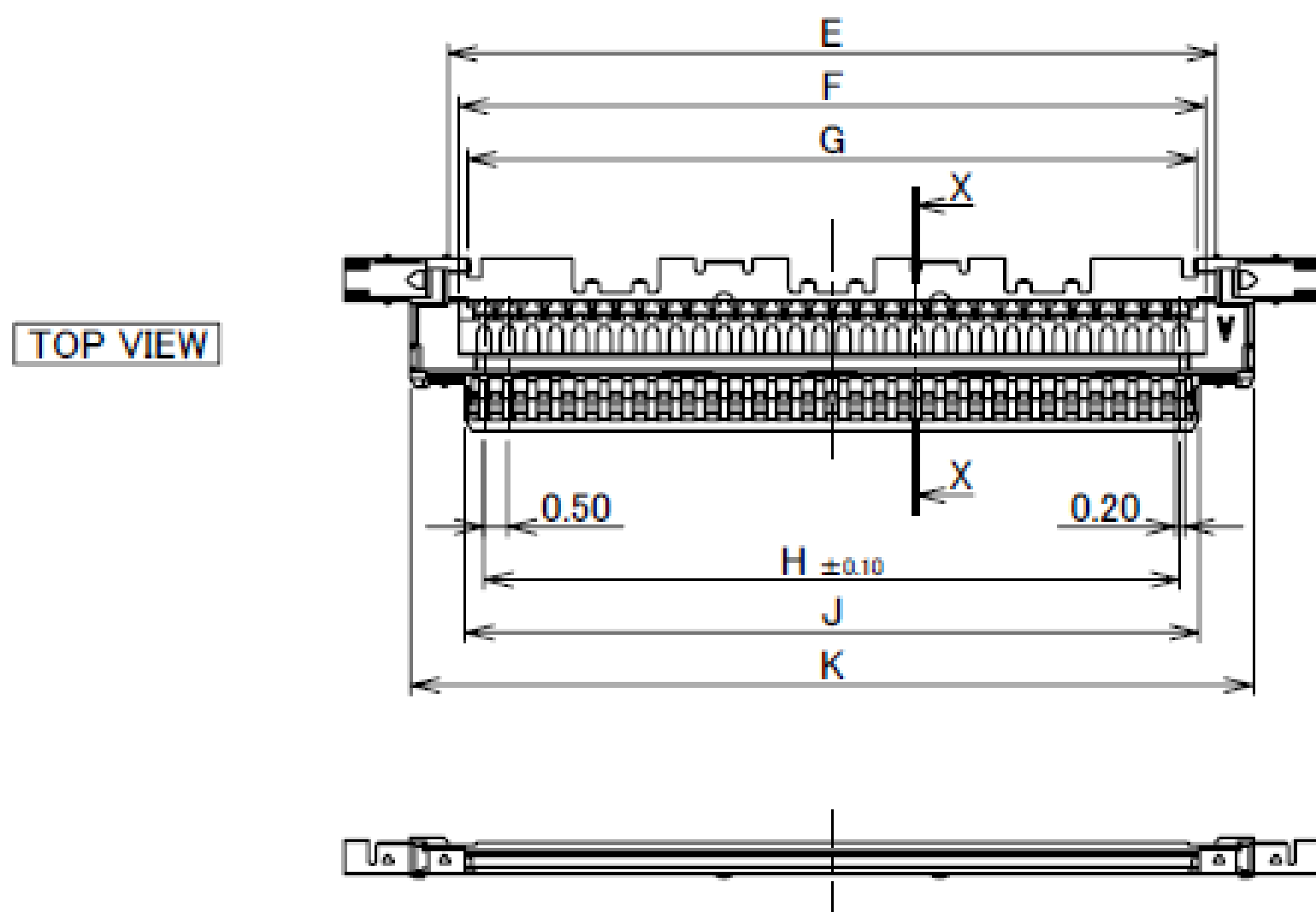
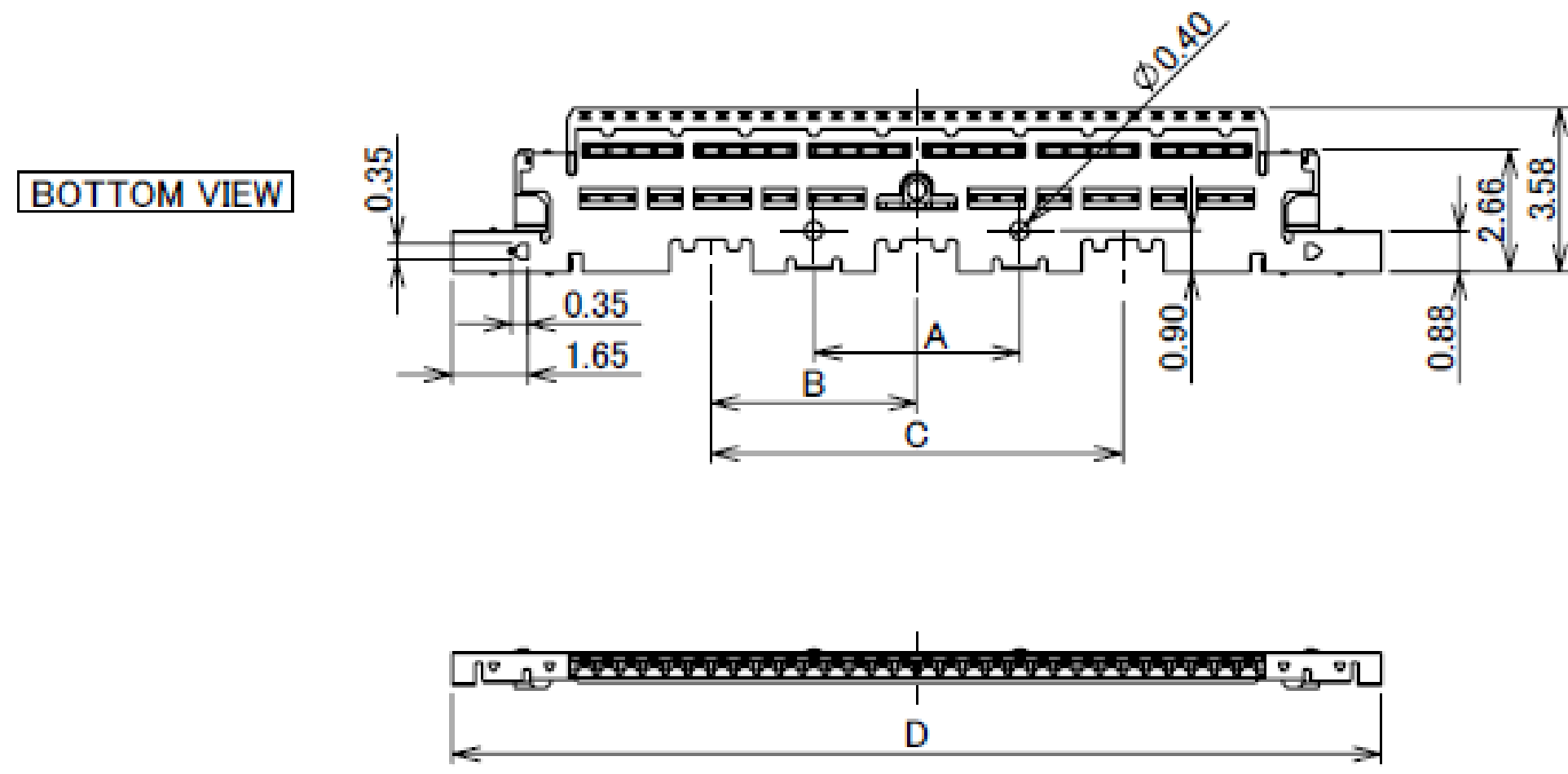
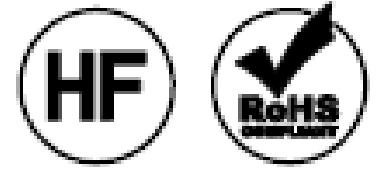

SECT. X-X
(S=15/1)

NOTES.

- THIS PART IS ASSEMBLED WITH SHELL A(P/N 3427-0**1) AND LOCK BAR ASSY(P/N 20848-0**T-01) AFTER SOLDERING THE CABLE, AND SHALL BE ASSIGNED AS P/N 20846-0**T-0#

TABLE 1

PART NO.	CONTACT FINISH
20847-0**T-01	CONTACT & SOLDERING AREA : Au 0.03 μm MIN. OVER Ni 1.00 μm MIN.
20847-0**T-02	CONTACT AREA : Au 0.38 μm MIN. OVER Ni 1.27 μm MIN. SOLDERING AREA : Au 0.03 μm MIN. OVER Ni 1.00 μm MIN.

Rev.6

Plug Shell-A

Recommended P/N 3427-0**1

PART No.	Pos.	A	B	C	D	E
3427-0201	20	15.30	9.78	12.56	3.00	6.00
3427-0301	30	20.30	14.78	17.56	4.00	12.00
3427-0401	40	25.40	19.88	22.56	4.00	16.00

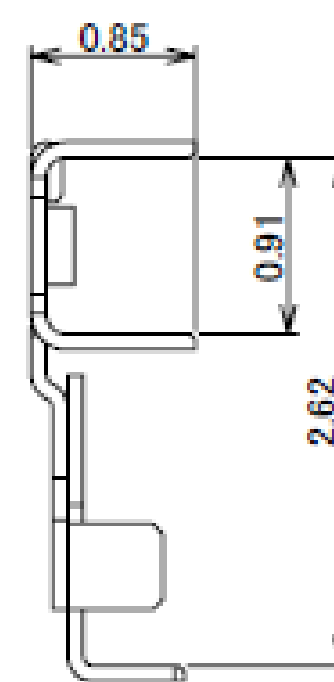
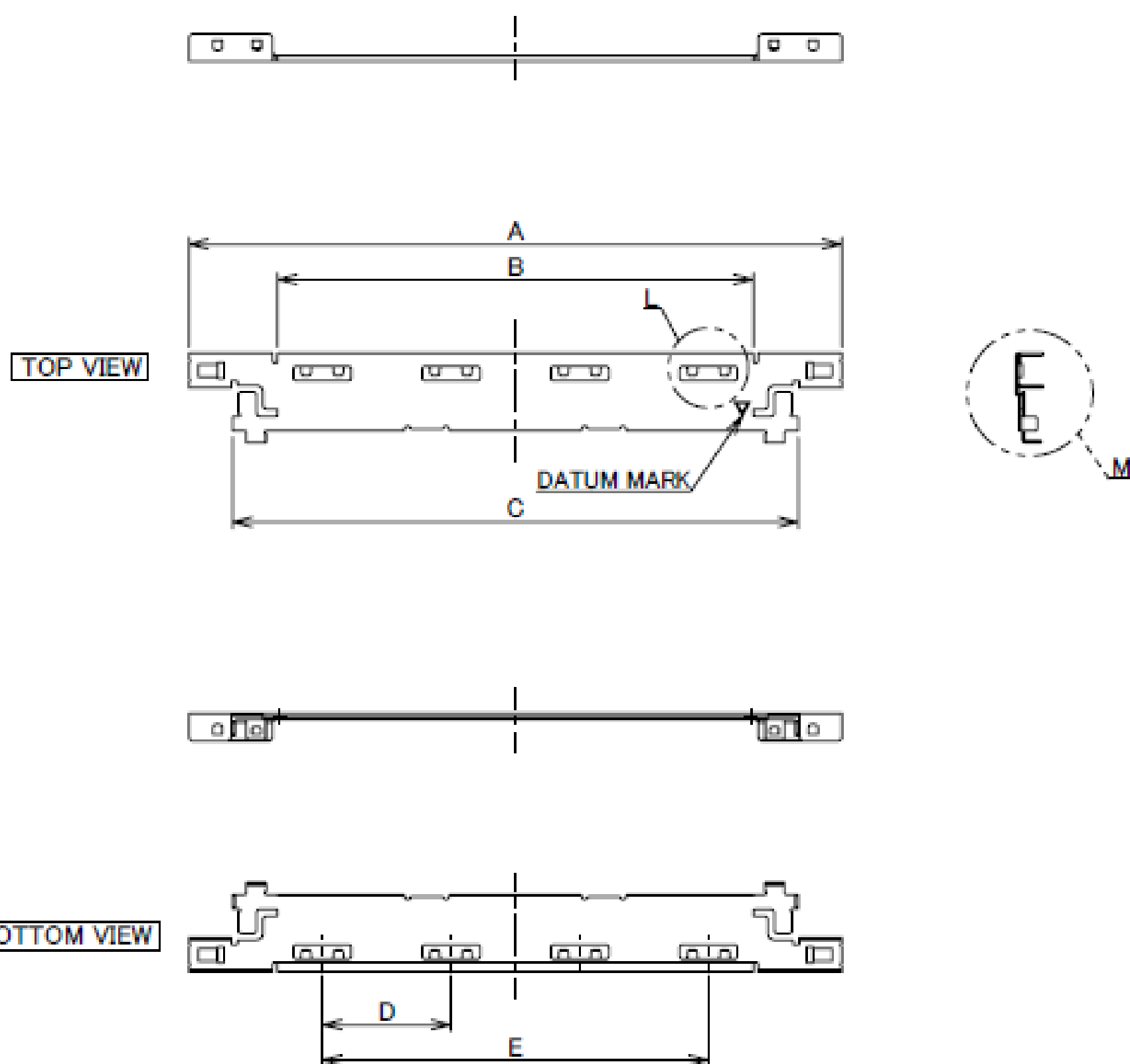
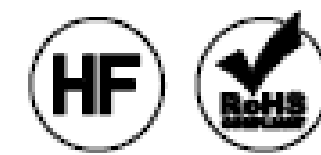

VIEW M
(S=20/1)

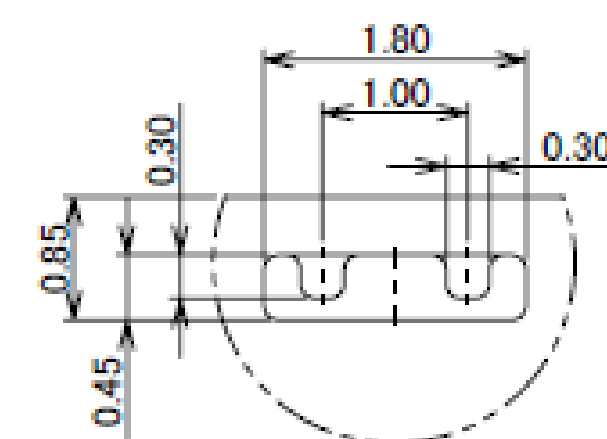
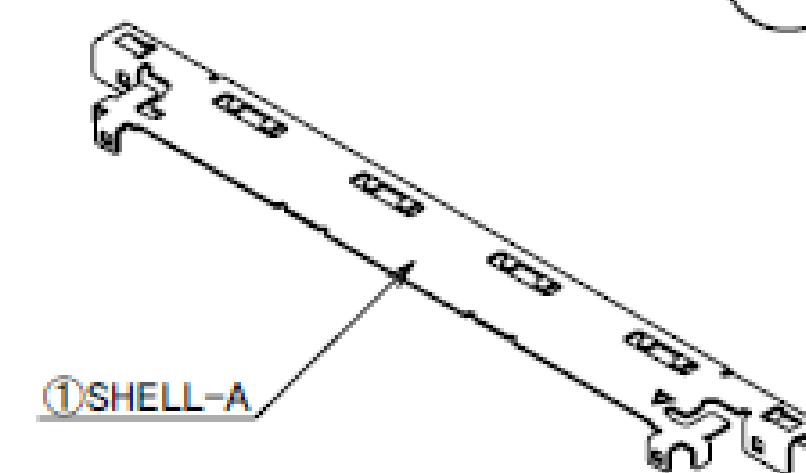

DETAIL L
(S=15/1)

NO.	DISCRIPTION	MATERIAL	FINISH , REMARKS
1	SHELL-A	PHOSPHOR BRONZE	PARTIAL Au 0.003 μm MIN. OVER Ni 1.00 μm MIN.

Rev.3

Plug Lock Bar Assembly

Recommended P/N		20848-0**T-01				
PART NO.	Pos.	A	B	C	D	E
20848-020T-01	20	14.59	12.70	7.50	15.75	7.00
20848-030T-01	30	19.59	17.70	12.00	20.75	12.00
20848-040T-01	40	24.59	22.70	18.00	25.75	17.00

20848-0**T-01
POS.

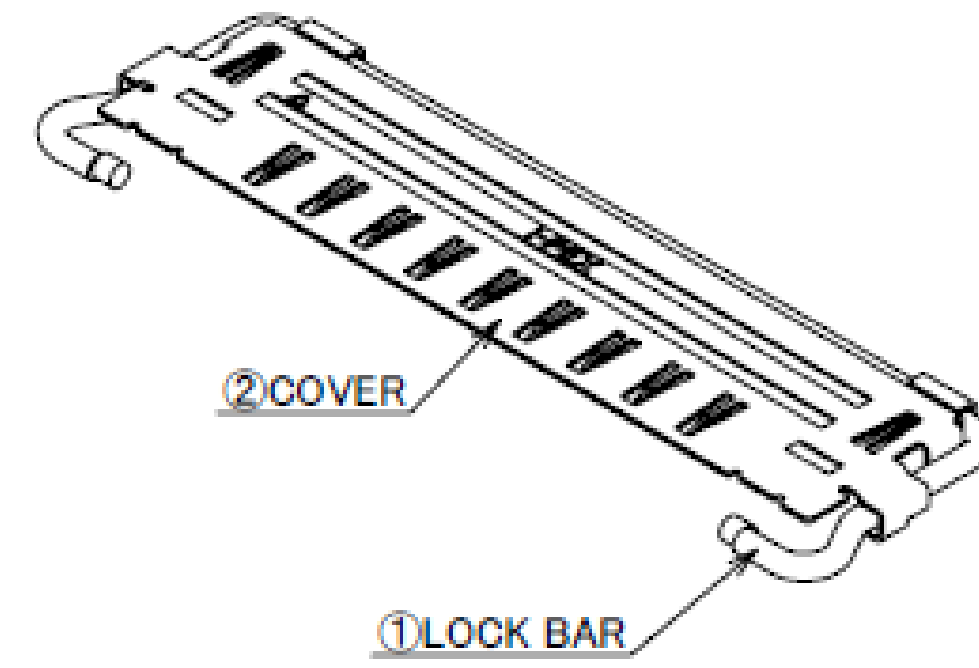
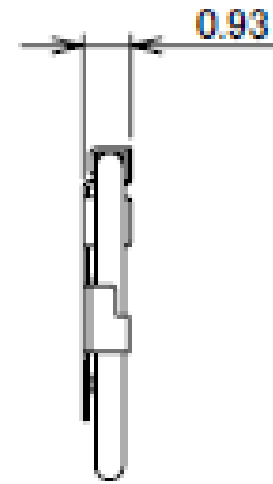
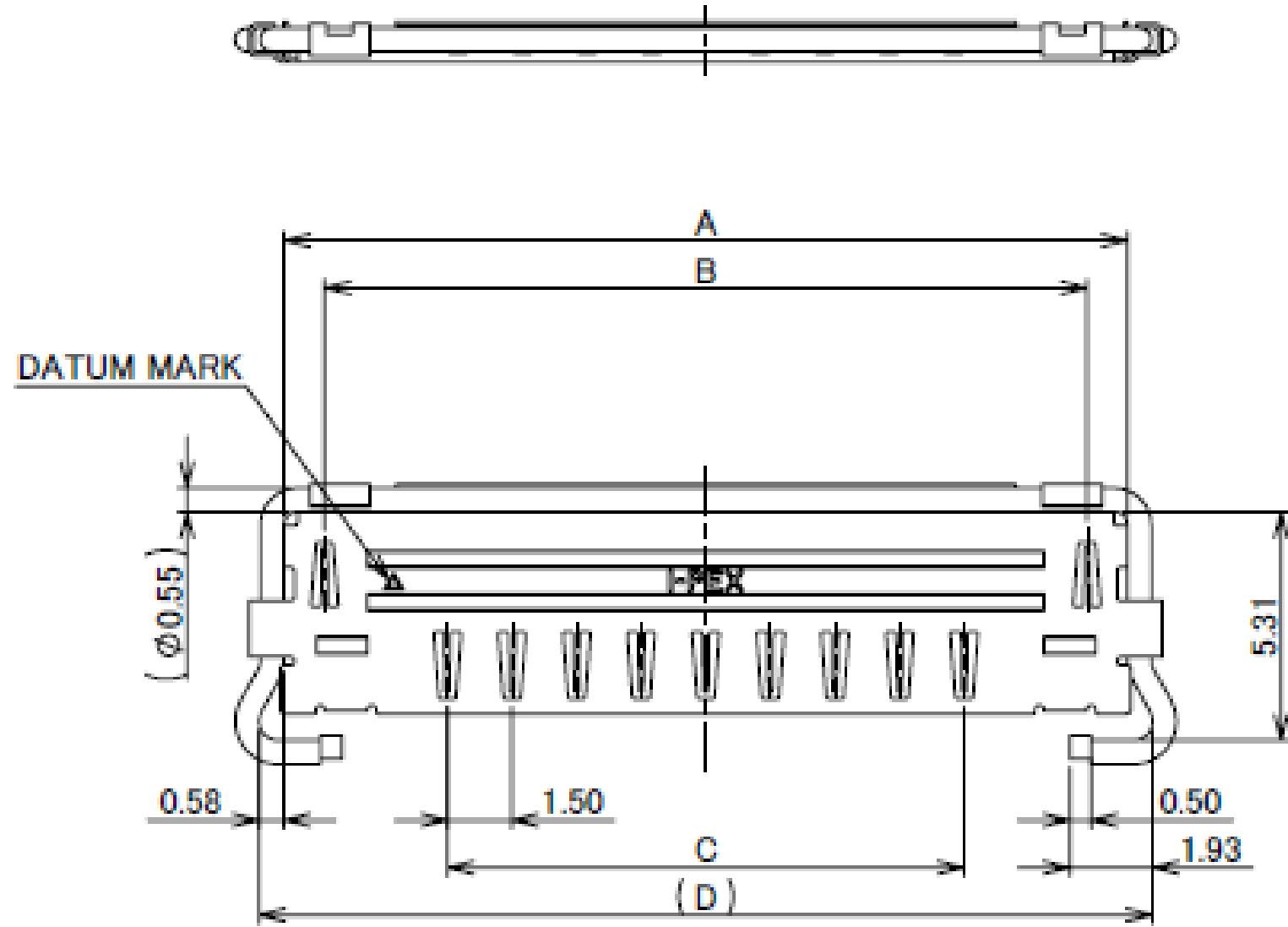
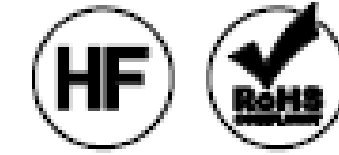

NO.	DISCRIPTION	MATERIAL	FINISH , REMARKS
2	COVER	PHOSPHOR BRONZE	ALL OVER Ni 1.00 μm MIN.
1	LOCK BAR	SUS φ0.55	-

Rev.6

Receptacle Assembly

Recommended P/N		20849-0**E-01				
PART NO.	Pos.	A	B	C	D	E
20849-020E-0#	20	11.30	9.50	14.33	15.10	11.91
20849-030E-0#	30	16.30	14.50	19.33	20.10	16.91
20849-040E-0#	40	21.30	19.50	24.33	25.10	21.91

P/N : 20849-0**E-0#
SEE TABLE 1
POS.

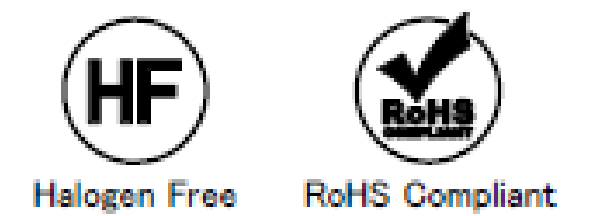
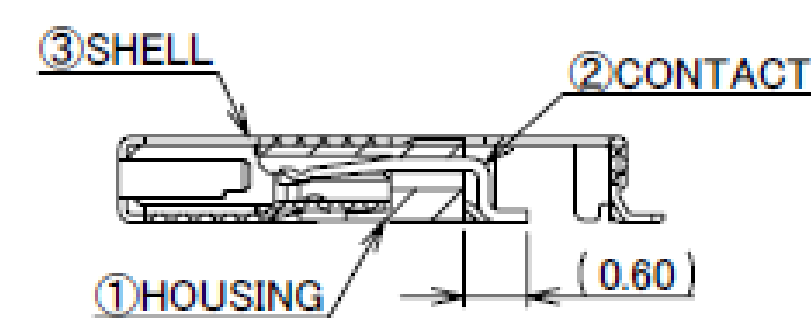

SECT. W-W
(S = 10 : 1)

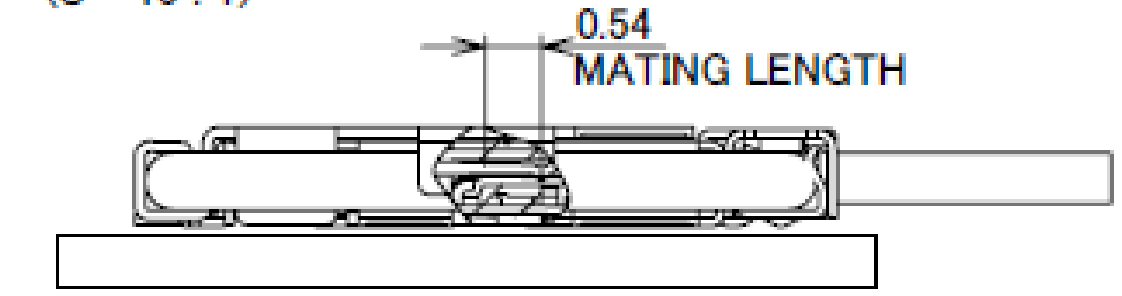

MATING CONDITION
(S = 10 : 1)

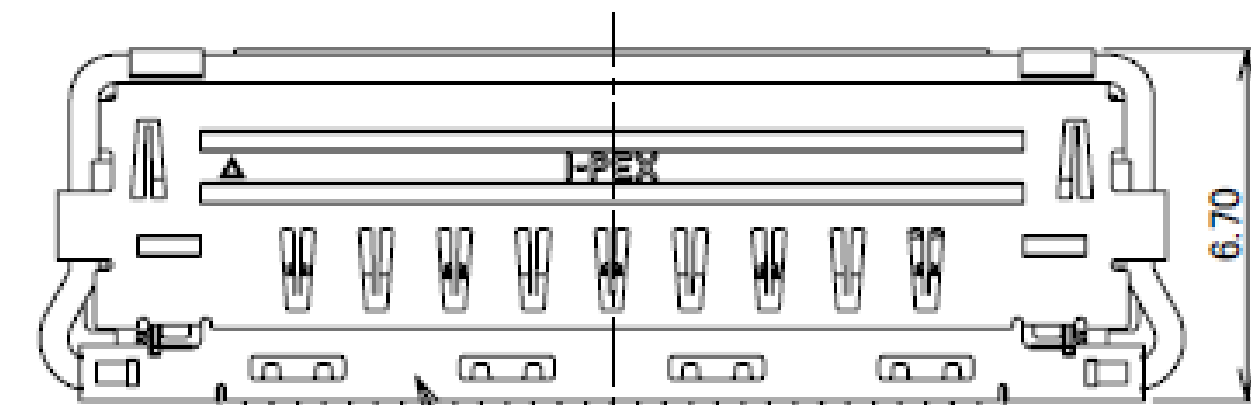

MATING CONDITION

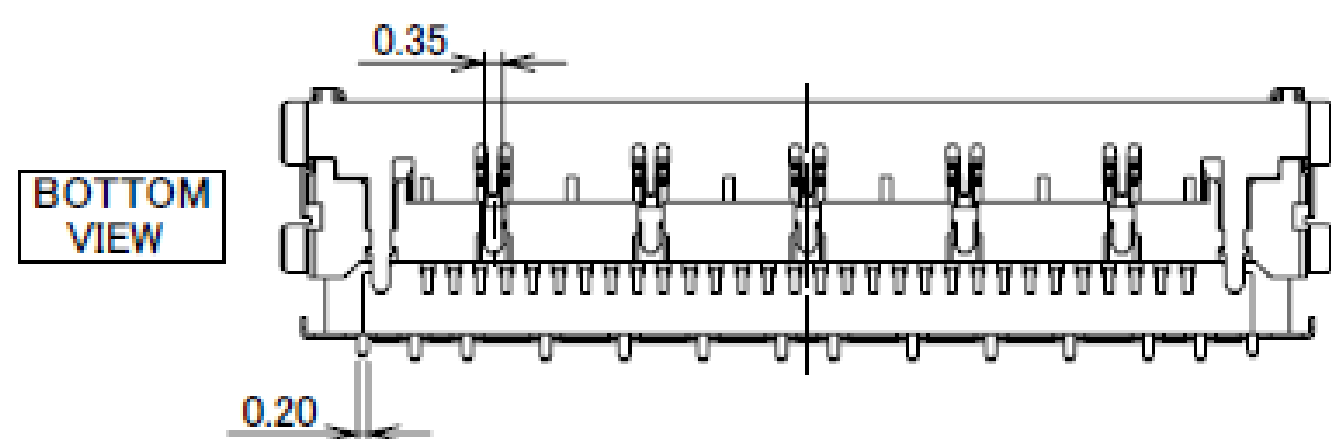
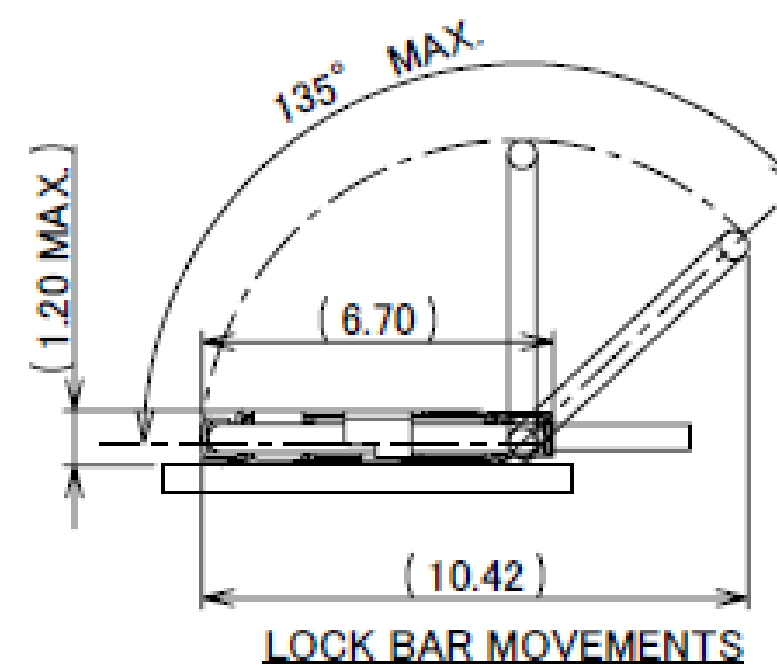
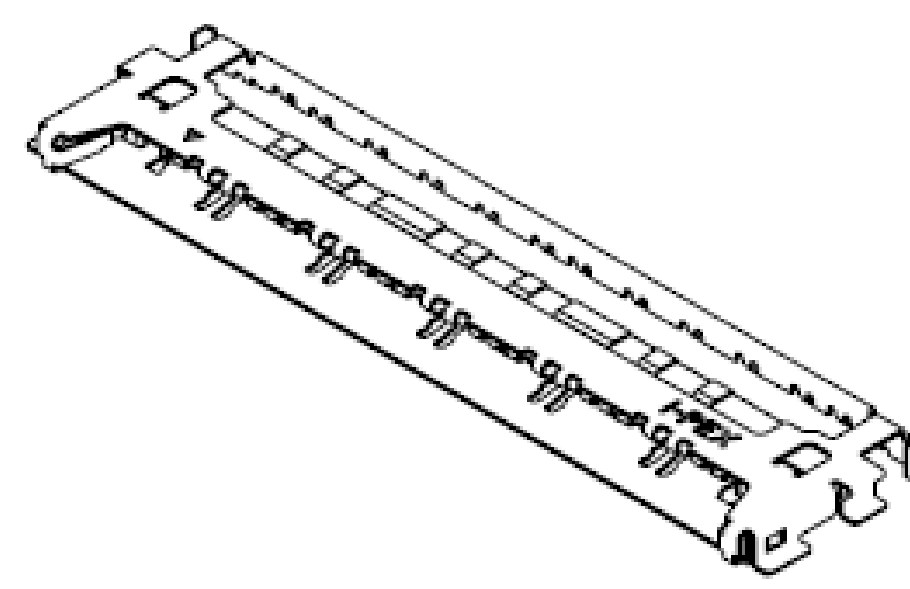
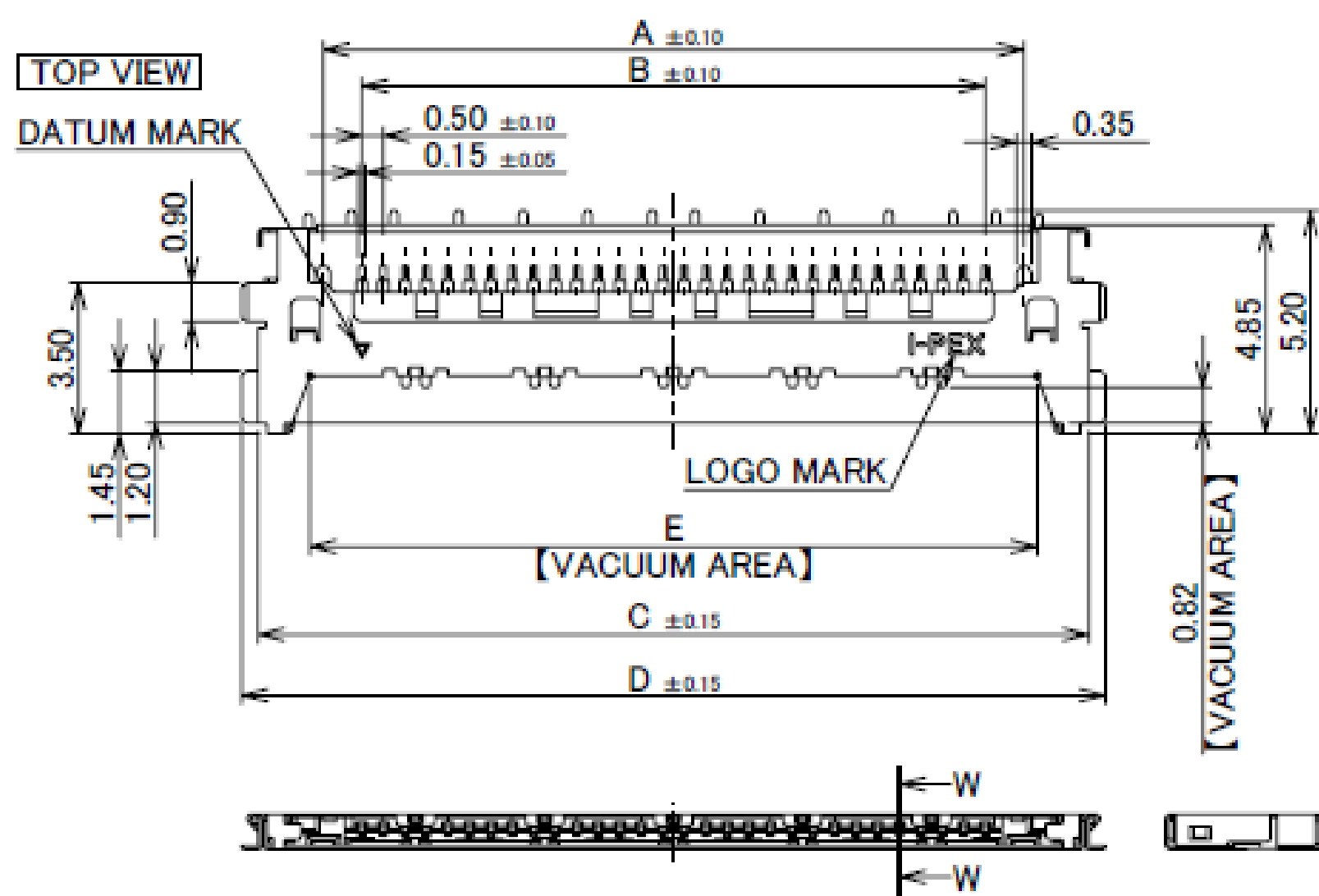

TABLE.1

PART NO.	CONTACT FINISH	SHELL FINISH
20849-0**E-01	CONTACT & SOLDERING AREA : Au 0.03 μm MIN. OVER Ni 1.00 μm MIN.	ALL OVER Ni 1.00 μm MIN.
20849-0**E-02	CONTACT AREA : Au 0.38 μm MIN. OVER Ni 1.27 μm MIN. SOLDERING AREA : Au 0.03 μm MIN. OVER Ni 1.00 μm MIN.	SOLDERING AREA : Au 0.02 μm MIN.

NO.	DISCRIPTION	MATERIAL	FINISH , REMARKS
3	SHELL	PHOSPHOR BRONZE	SEE TABLE 1
2	CONTACT	PHOSPHOR BRONZE	SEE TABLE 1
1	HOUSING	LCP	UL94V-0, BLACK

Rev.10

Receptacle Assembly

PART NO.	Pos.
20849-020E-0#	20
20849-030E-0#	30
20849-040E-0#	40

BOTTOM VIEW

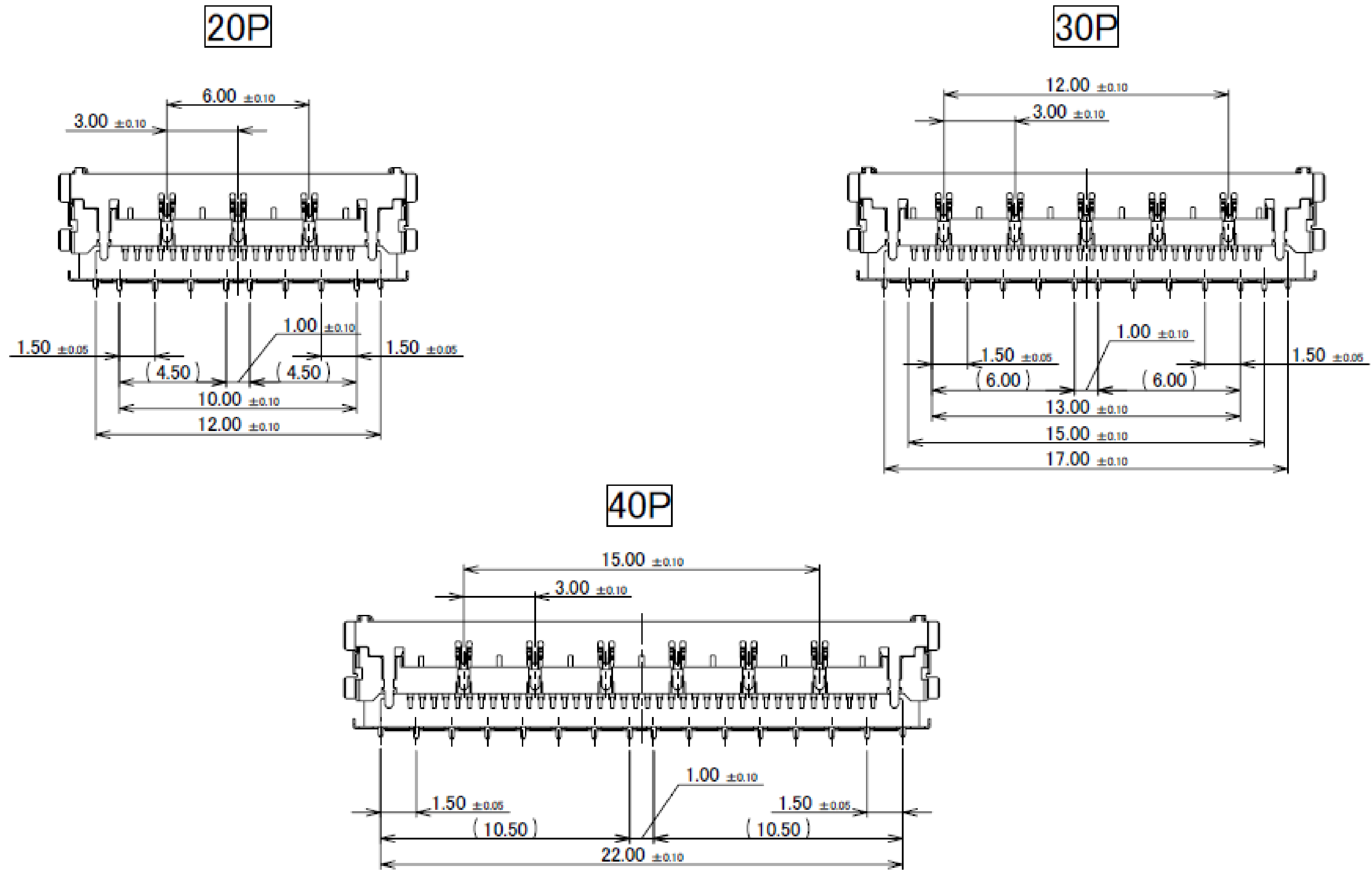

Rev.10

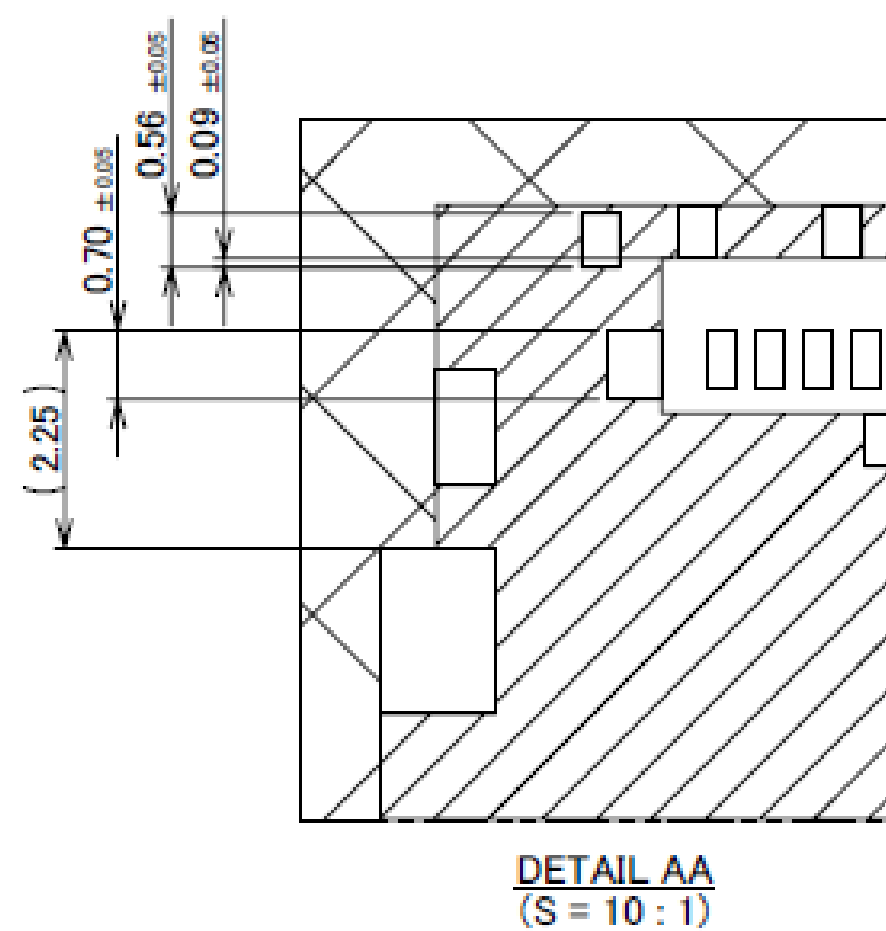
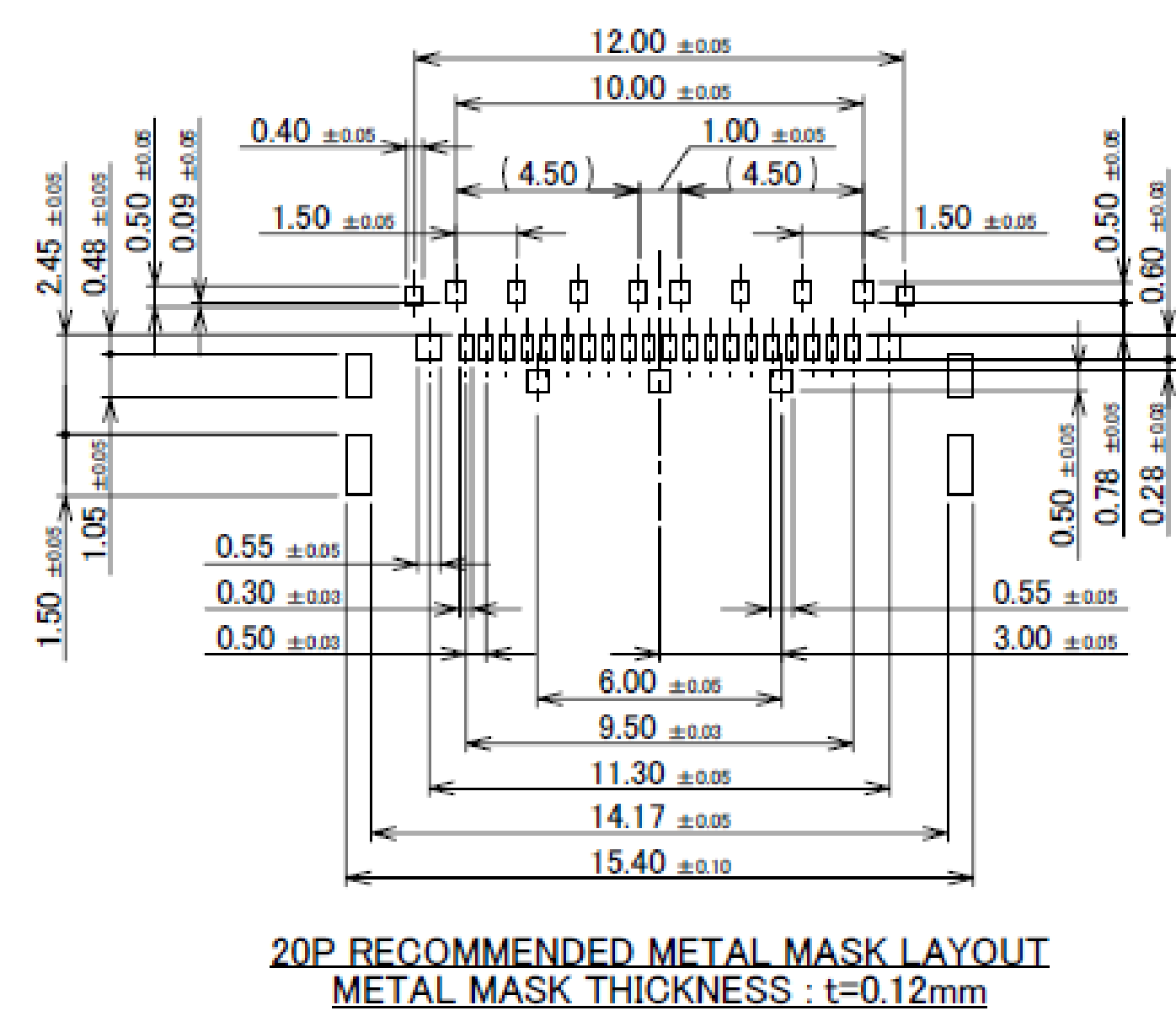
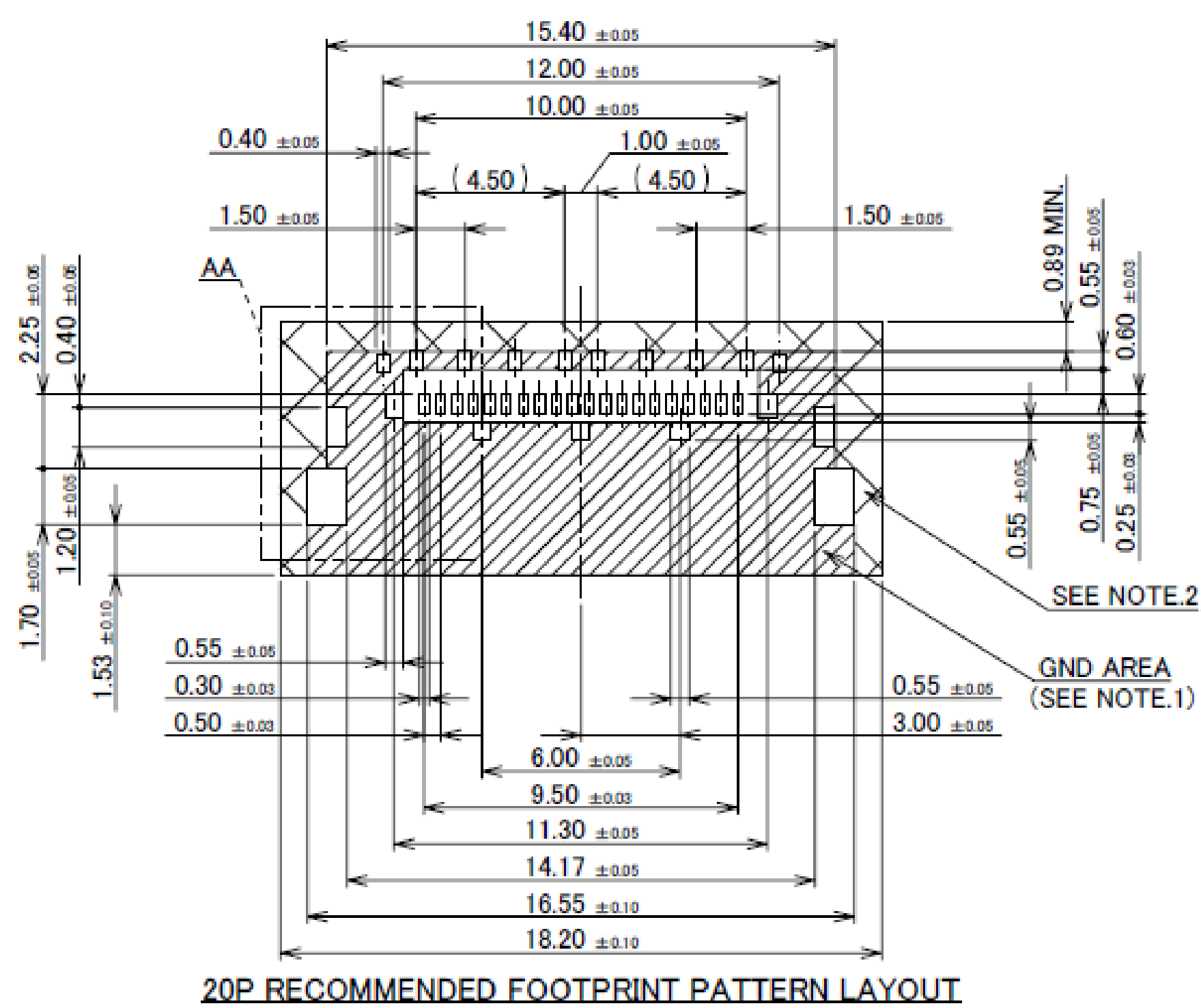

- NOTES.
1. SOLDER RESIST MUST BE APPLIED TO THIS AREA.
 2. DO NOT MOUNT ANOTHER COMPONENT IN THIS AREA.

Rev.10

Receptacle Assembly

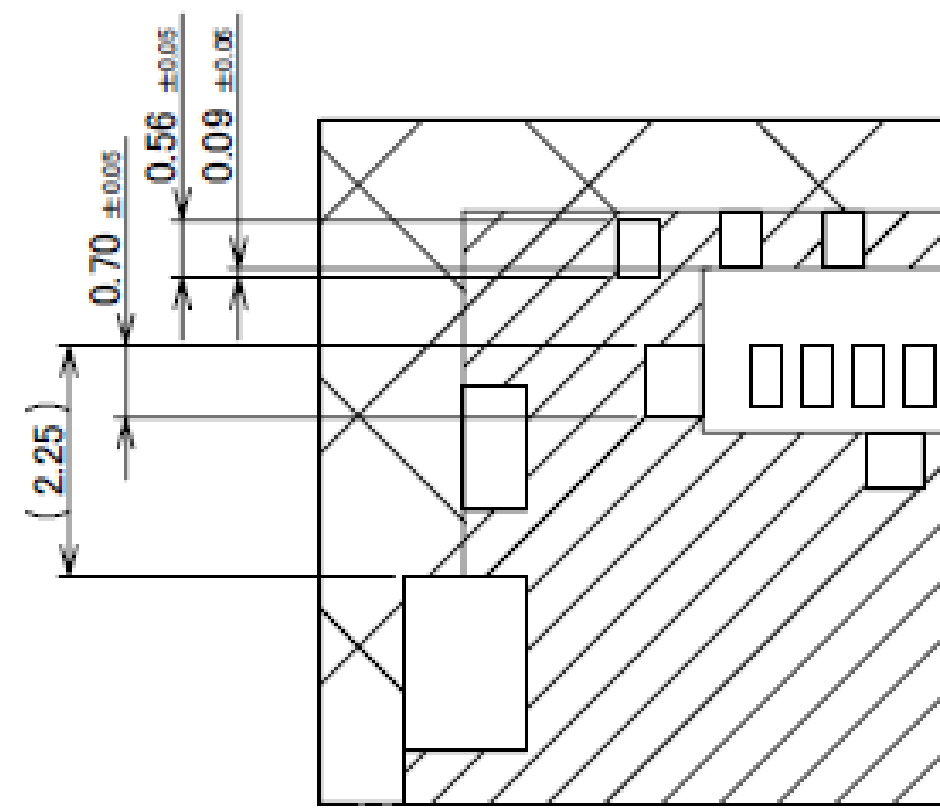
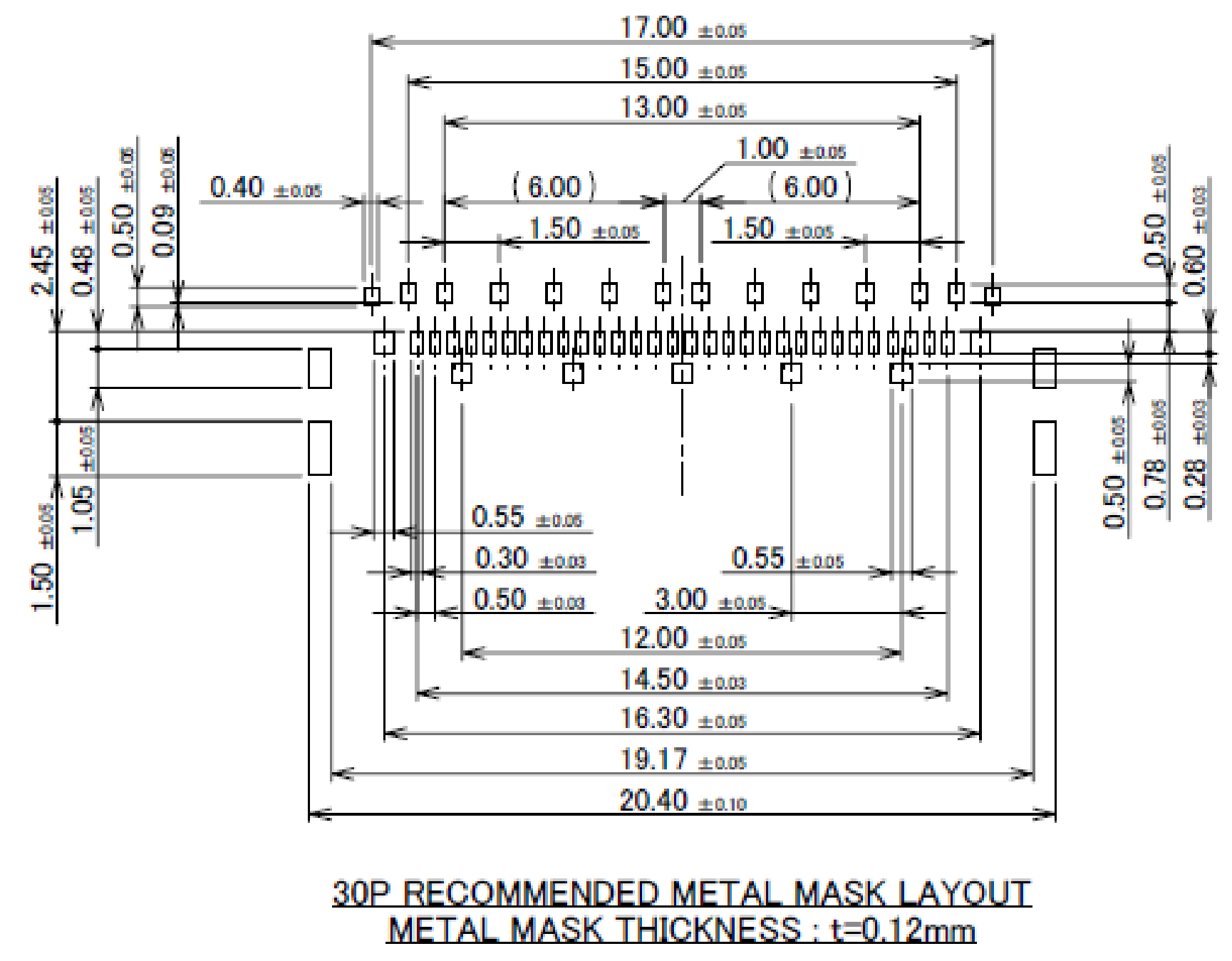
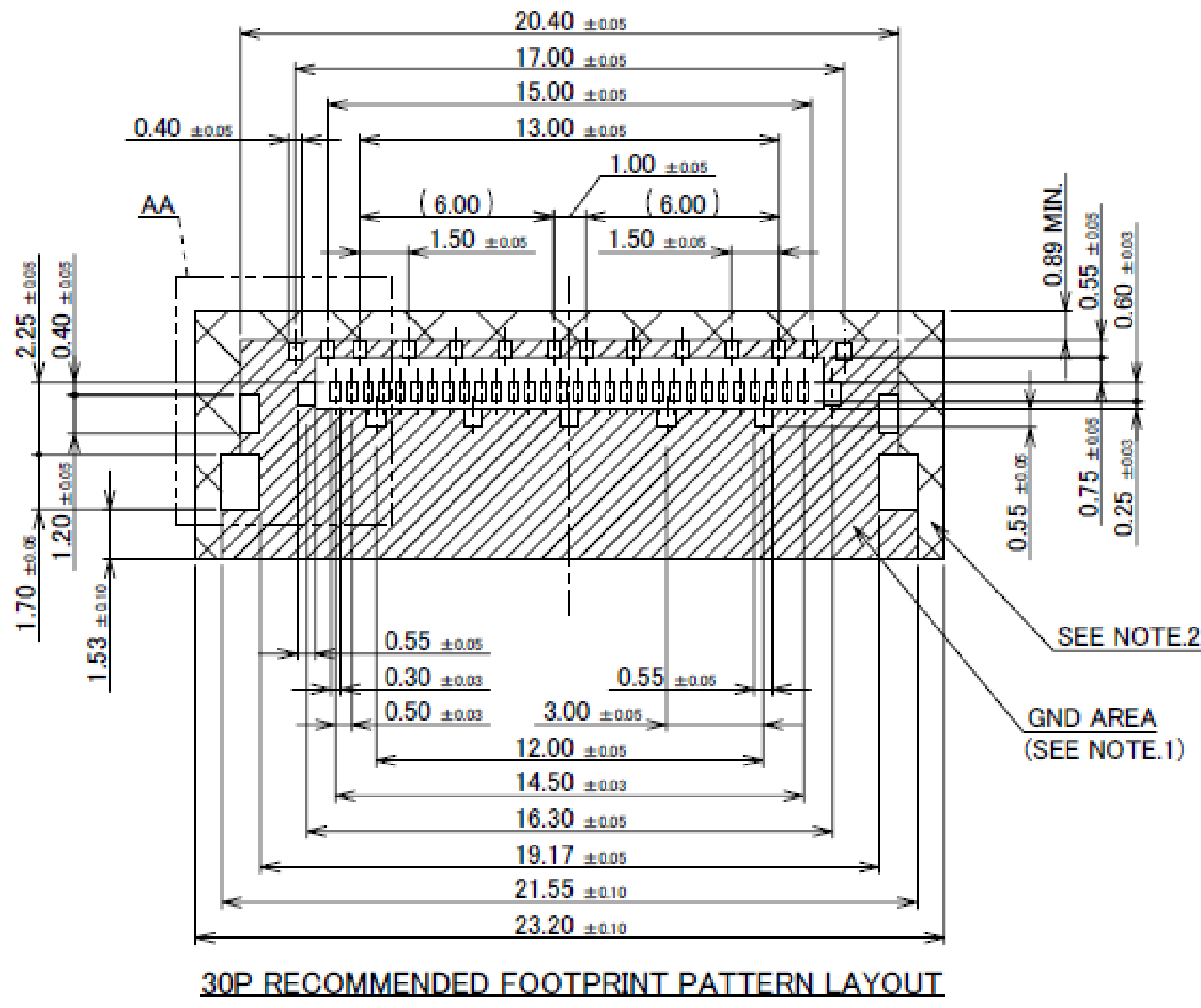

NOTES.
1. SOLDER RESIST MUST BE APPLIED TO THIS AREA.
2. DO NOT MOUNT ANOTHER COMPONENT IN THIS AREA.

Rev.10

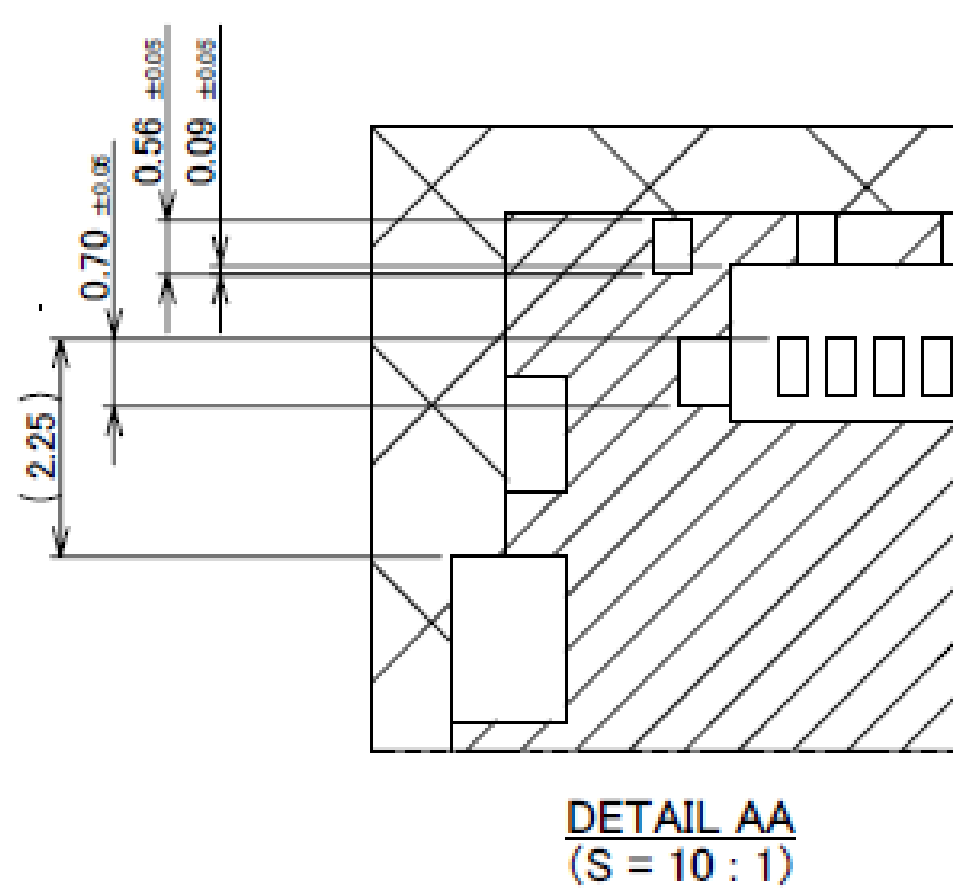
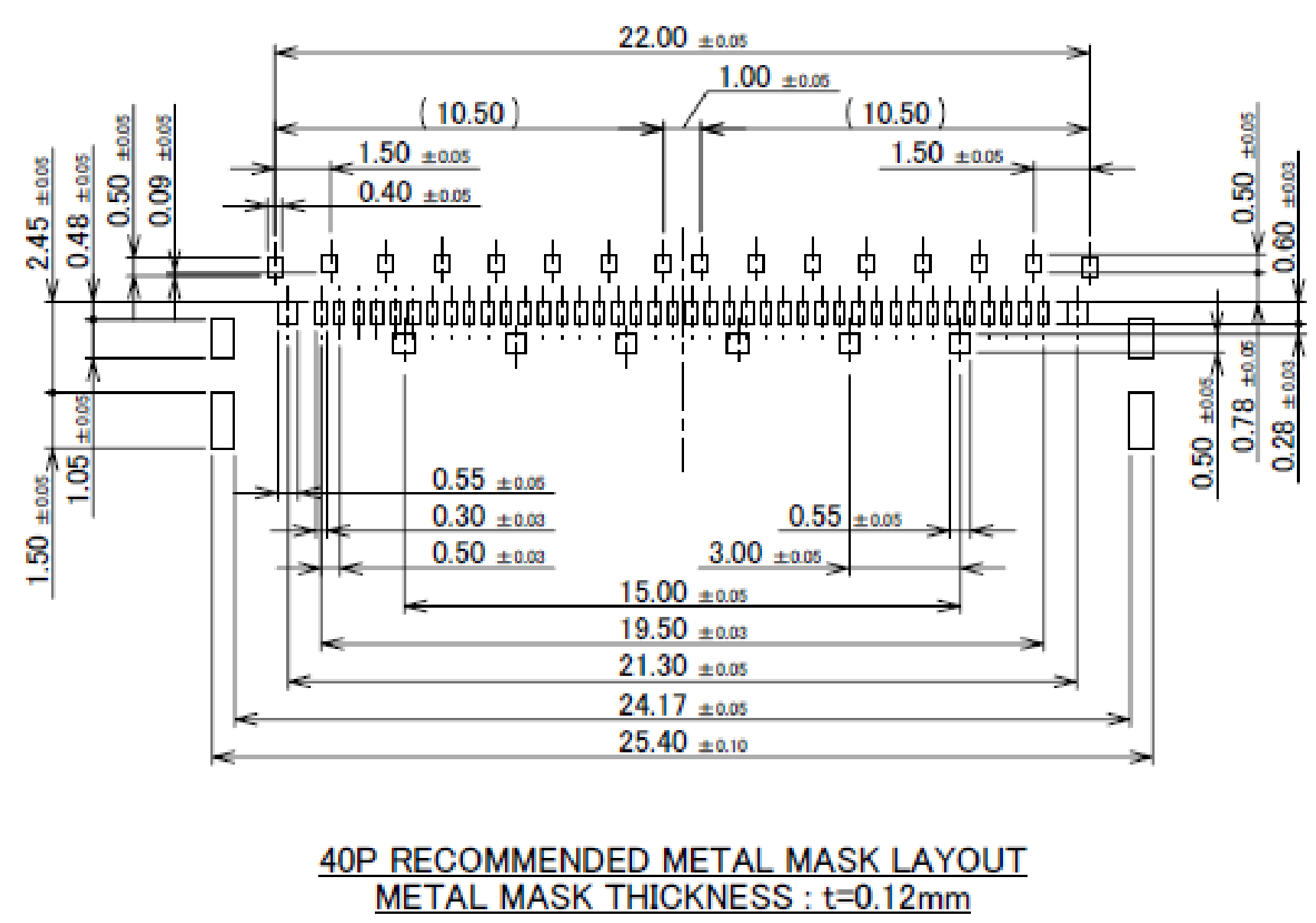
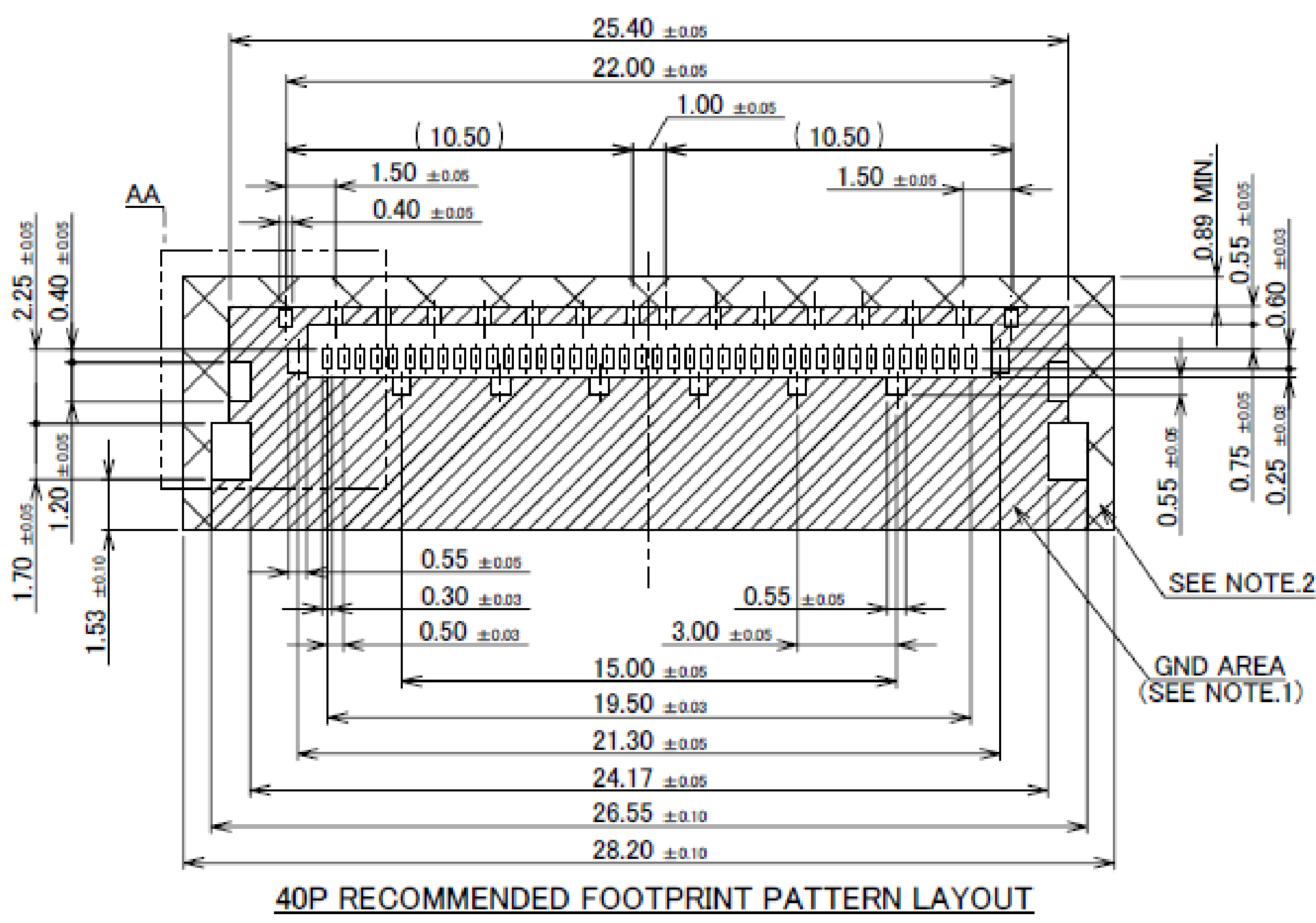

NOTES.
1. SOLDER RESIST MUST BE APPLIED TO THIS AREA.
2. DO NOT MOUNT ANOTHER COMPONENT IN THIS AREA.

Rev.10

Receptacle Assembly

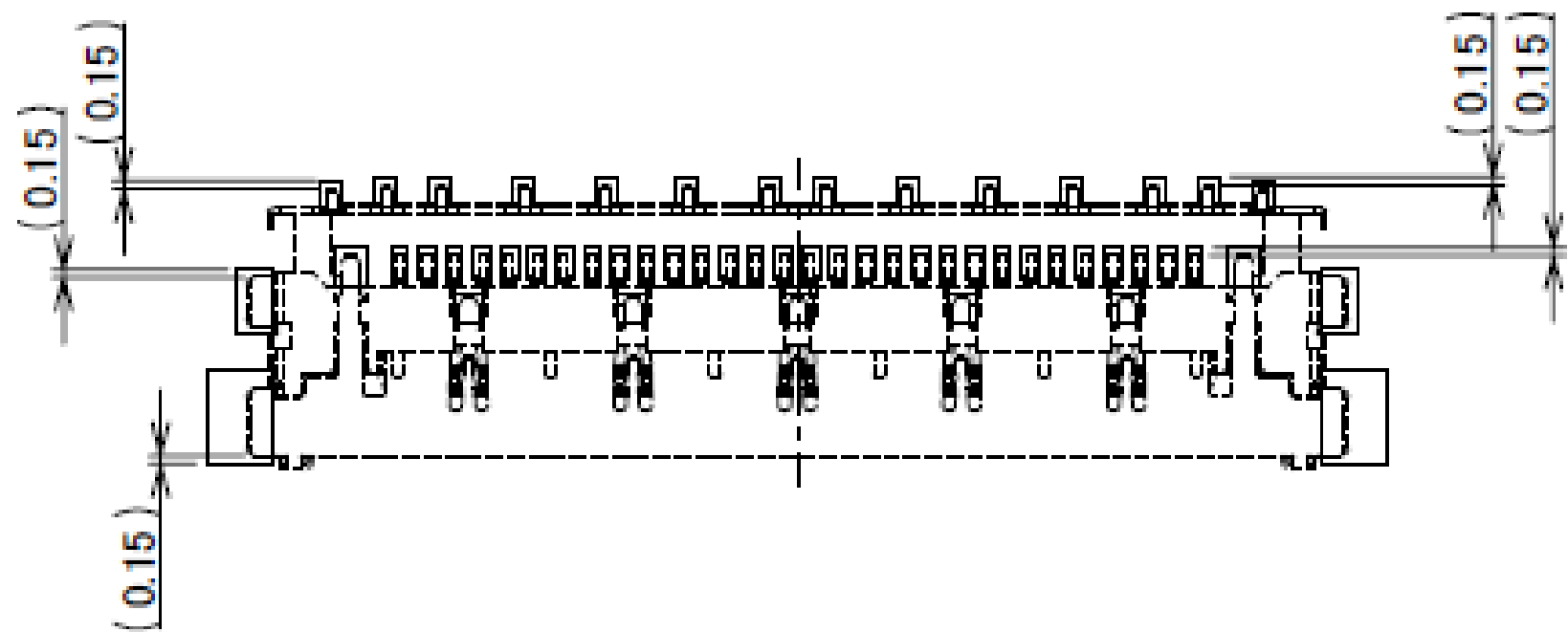

CONNECTOR ON RECOMMENDED FOOTPRINT PATTERN

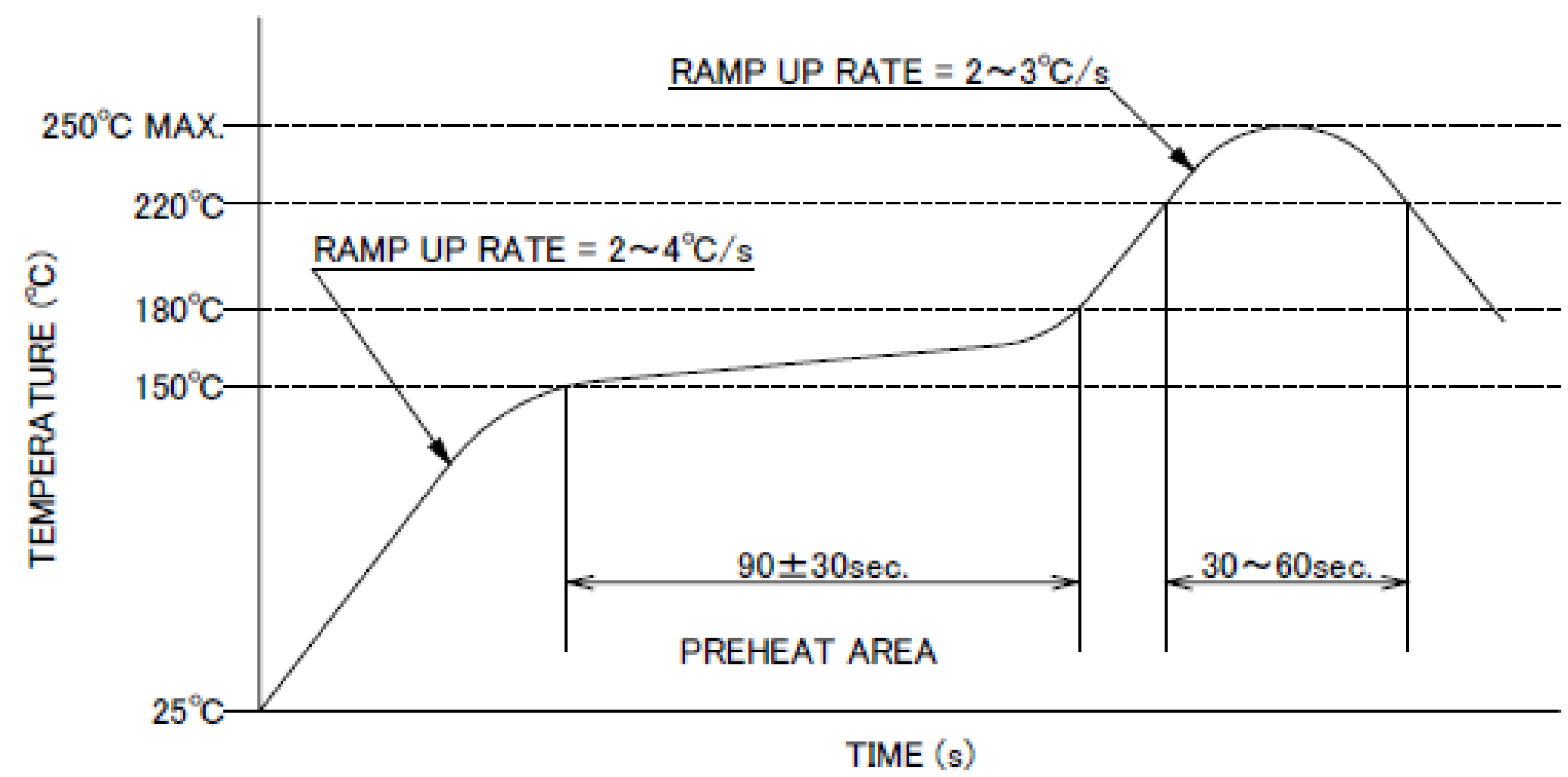

Rev.10

ITEMS	SPECIFICATION
APPLICABLE CABLE	MICRO-COAXIAL CABLE : AWG# 44 , 42 , 40 , 38 , 36 DISCRETE WIRE : AWG# 36 , 34 , 32 TWINAX CABLE : AWG# 40
RATING VOLTAGE	100V AC (PER CONTACT PIN)
RATING AMPERAGE (FOR CONTACT)	0.1A AC/DC [AWG#44] PER CONTACT PIN/UP TO 40 CONTACTS 0.24A AC/DC [AWG#42] PER CONTACT PIN/UP TO 40 CONTACTS 0.3A AC/DC [AWG#40] PER CONTACT PIN/UP TO 40 CONTACTS 0.5A AC/DC [AWG#38] PER CONTACT PIN/UP TO 23 CONTACTS 0.8A AC/DC [AWG#36] PER CONTACT PIN/UP TO 10 CONTACTS 1.0A AC/DC [AWG#34] FOR POWER PER CONTACT/UP TO 9 CONTACTS 1.0A AC/DC [AWG#32] FOR POWER PER CONTACT/UP TO 9 CONTACTS ※TESTING BY A REAL MACHINE IS RECOMMENDED BECAUSE TEMPERATURE RISE MAY AFFECTED BY ACTUAL SITUATION
OPERATING TEMPERATURE	233~378K(-40°C~+105°C)
OPERATING HUMIDITY	85% MAX.(NON-CONDENSING)
CONTACT RESISTANCE	INITIAL : 140mohm MAX.(AWG#32) / AFTER TEST : \triangleleft140mohm MAX. 180mohm MAX.(AWG#34) 275mohm MAX.(AWG#36) 360mohm MAX.(AWG#38) 600mohm MAX.(AWG#40) 700mohm MAX.(AWG#42) 1080mohm MAX.(AWG#44)
GROUND SHELL RESISTANCE	INITIAL : 50mohm MAX. / AFTER TEST : \triangleleft140mohm MAX.
INSULATION RESISTANCE	INITIAL : 1000Mohm MIN. / AFTER TEST : 500Mohm MIN.
DIELECTRIC WITHSTANDING VOLTAGE	AC250V 1min
DURABILITY	30 CYCLES
MATING FORCE (INITIAL / AFTER 30 CYCLES)	20P : 9.70N MAX. 30P : 14.55N MAX. 40P : 19.40N MAX.
UNMATING FORCE (INITIAL / AFTER 30 CYCLES)	20P : 2.00N MIN. 30P : 3.00N MIN. 40P : 4.00N MIN.
CABLE RETENTION FORCE	20P : 9.80N MIN. 30P : 14.70N MIN. 40P : 19.60N MIN.
PRODUCT SPECIFICATION	PRS-2398
TEST REPORT	TR-17060 (20846-0**T-01) / TR-18048 (20846-0**T-02)
INSTRUCTION MANUAL	HIM-17015
ASSEMBLY MANUAL	ASM-17005
APPEARANCE CRITERIA No.	QLS-A***

Rev.11

Custom Connectors Available

RF Connector

MHF® series



Micro-coaxial/Twinax/Discrete Wire Connector

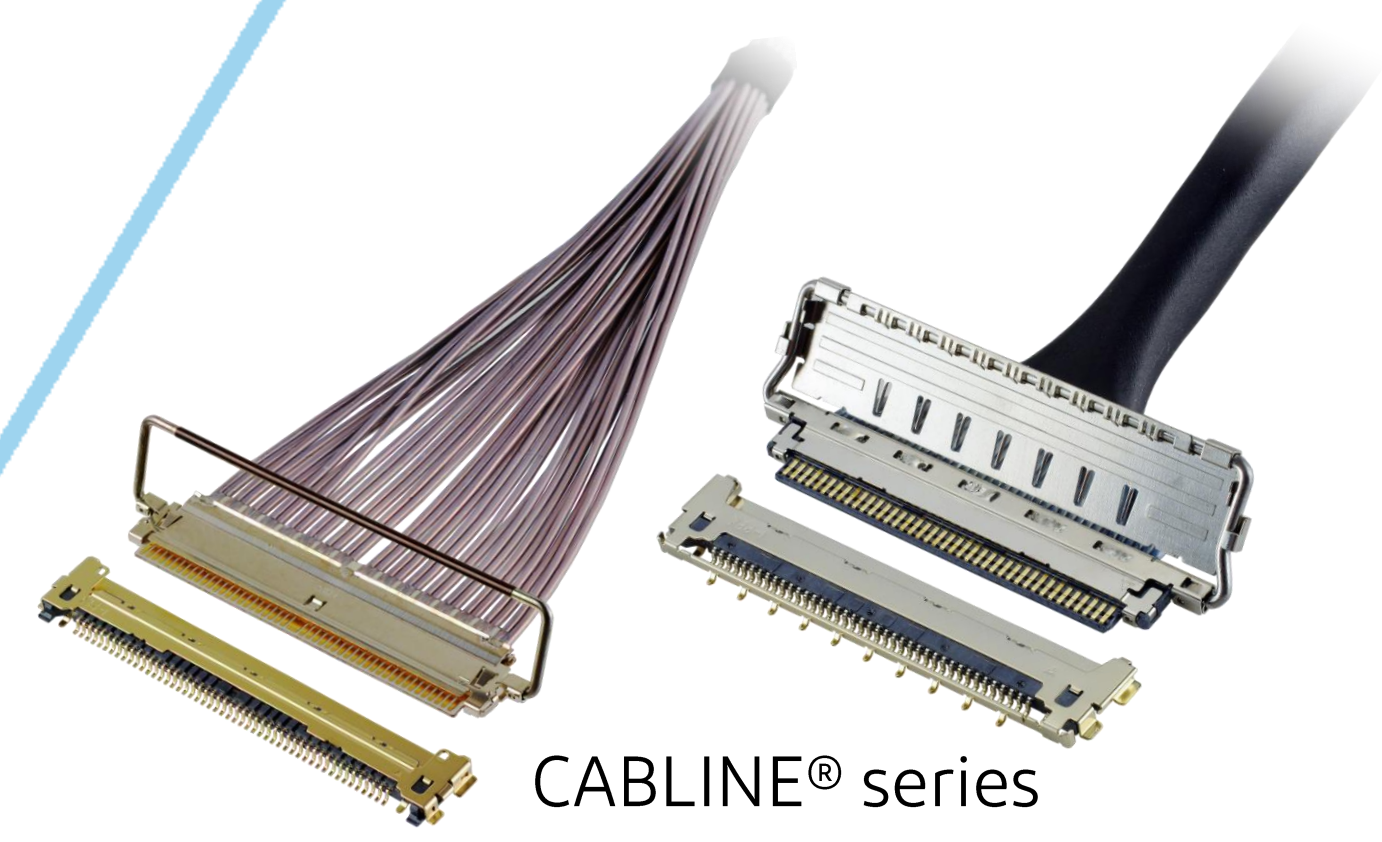

CABLINE® series



Optical Module

LIGHTPASS® series



NOVASTACK® series

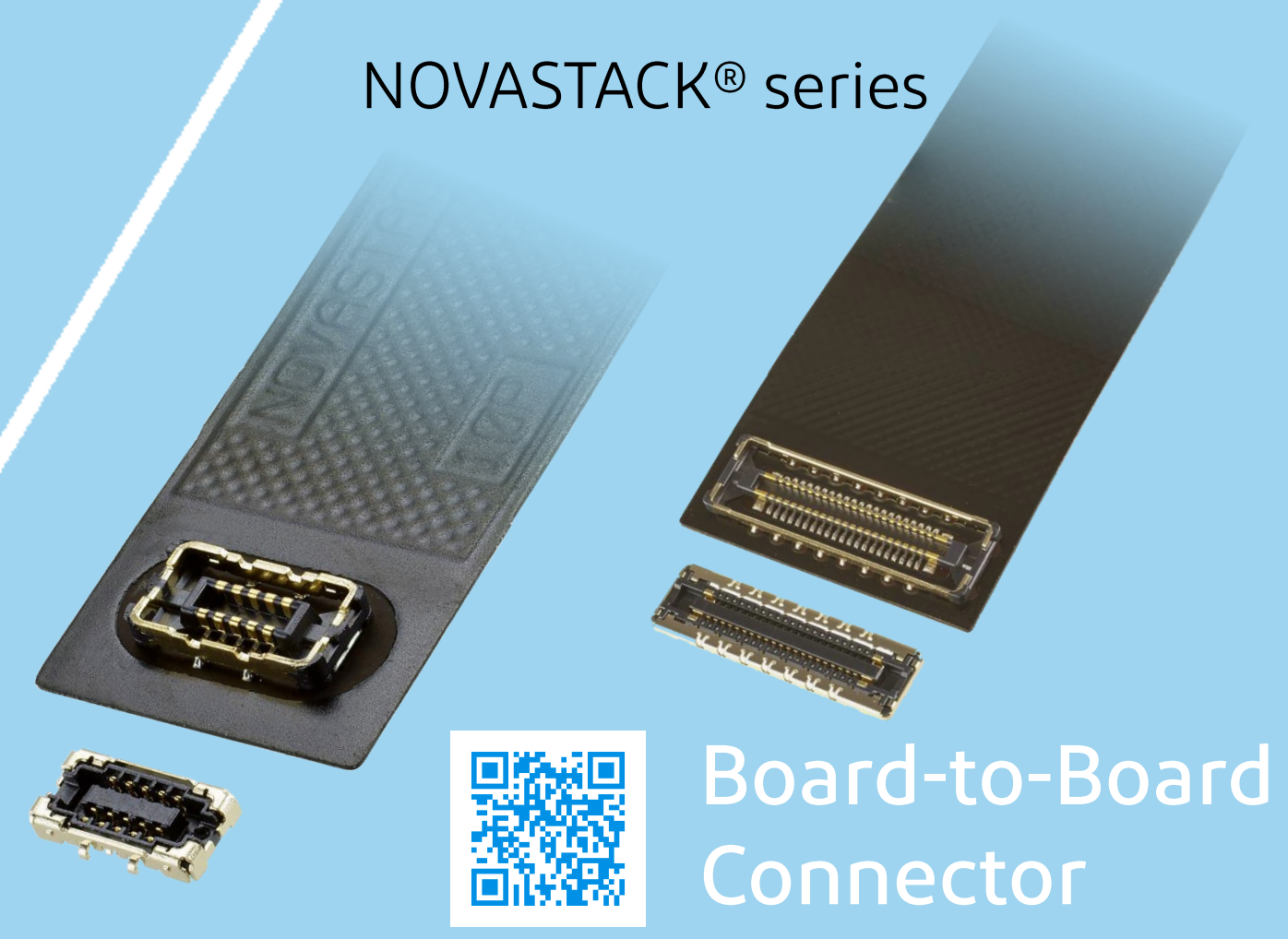

Board-to-Board Connector



Power Connector/Terminal

AP series

ISH® series



MINIFLEX® series

EVAFLEX® series



FPC FFC Connector



Inquiry



MINIDOCK® series



I/O Connector

I-PEX, MHF, CABLINE, LIGHTPASS, NOVASTACK, ISH, IARPB, MINIFLEX, EVAFLEX, MINIDOCKS and ZenShield are registered trademarks of I-PEX Inc. Please note that the contents in the catalog might be changed without prior notification. I-PEX Inc. assumes no responsibility for any inaccuracies or obligation to update information on these documents. Please be sure to read and understand the latest "Precautions for Use" and "Instruction Manual" before you use our products. We shall not be responsible for any defects, damages or troubles in case you use our products without following the precautions for use. Please feel free to contact our sales representatives when you use our products for any applications that require very high reliability and safety, or that relate to human life (ex. nuclear power control, aerospace, transportation, medical equipment, safety equipment etc.).

Contact your sales representative or more detailed information.

www.i-pex.com

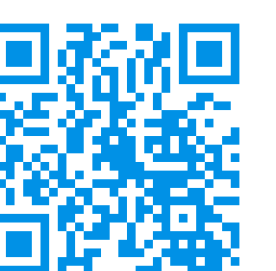

I-PEX

© I-PEX Inc. 2024
All rights reserved