

CABLINE®-VS IIF

全屏蔽设计，多点接地结构和机械锁扣，0.5mm 间距，水平对插款的FPC 型公头连接器

Product Specifications:

Mating type	Horizontal	
Board Pitch (mm)	0.5	
Wiping Length (mm)	0.48	
Mated size (mm)	Height	1.2 max. with cover
	Width	Formula: 6.85 + (0.5*?p)
	Depth	7.24
Pin Counts	Range	Up to 55
	Available	30, 40

Applicable FPC

FPC Type	Shielded FPC
FPC Pitch (mm)	0.5
FPC Contact Point	Top
FPC Thickness (mm)	Contact Area: 0.25 +0.02/-0.03
	Ground Area: 0.37 +0.04/-0.06

Applicable Standards (Reference Only):

USB4 Gen3 (20 Gbps/Lane) , Display Port UHBR20 (20 Gbps/Lane)
PCIe® Gen 4 (16 GT/s/Lane), eDP HBR 3 (8.1 Gbps/Lane)

*如您需要了解未列出或不在范围内的Pin数，请咨询我们。



▶ ZenShield® 的全屏蔽设计和多点接地结构，有效防止EMI外泄

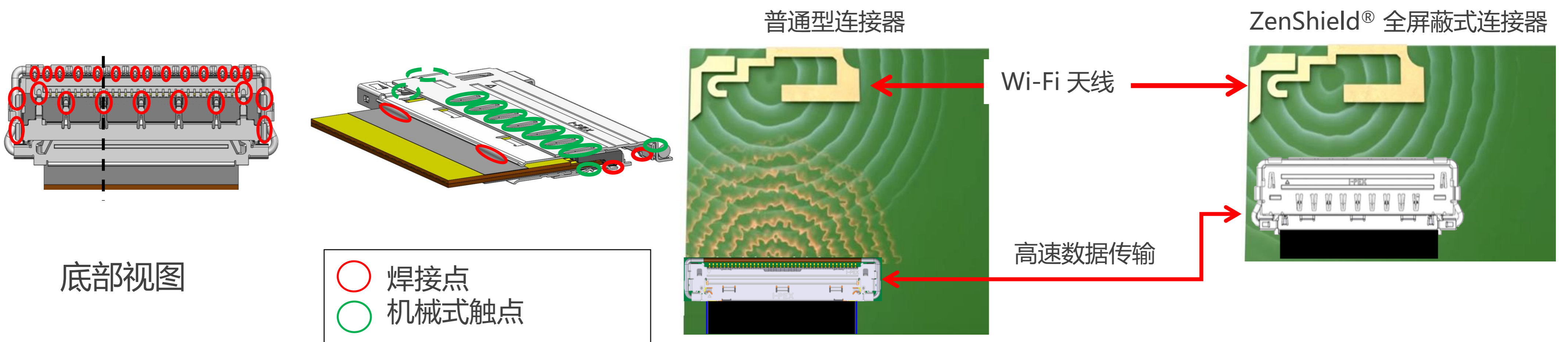

▶ 机械式锁扣罩防止连接器不完全嵌合及脱落/未嵌合

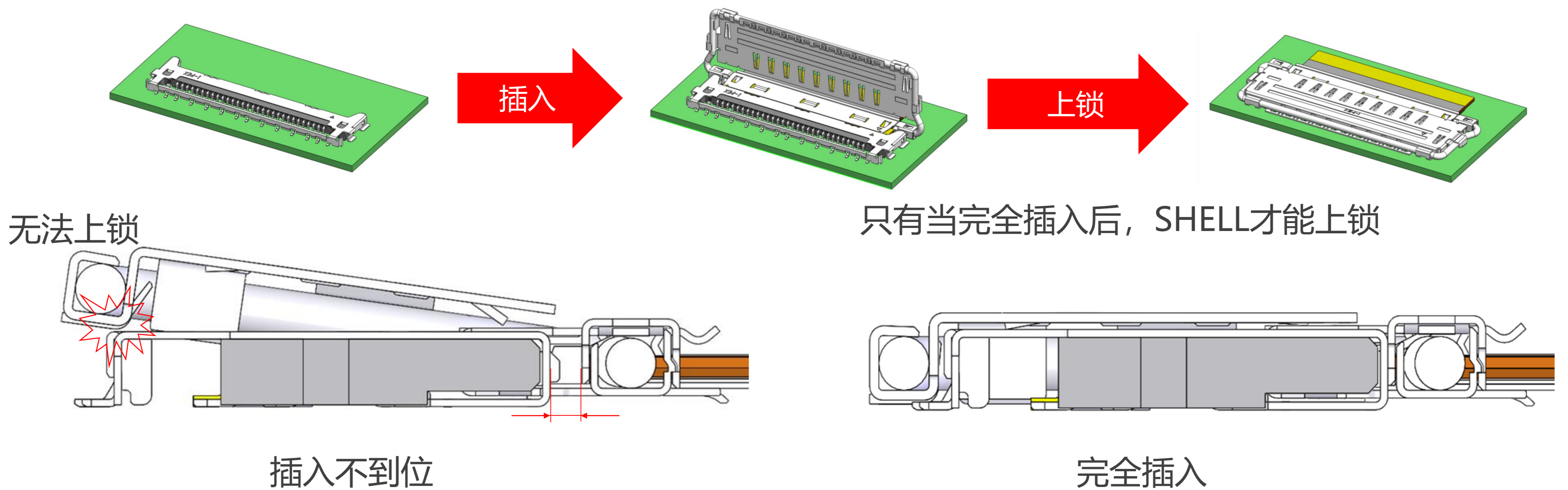

▶ I-PEX VS 系列多款连接器可选

I-PEX VS 系列 (0.5mm 间距, 水平对插方式)

CABLINE-VS, VS II 的母座和 EVAFLEX® 5-VS 可以安装在相同布局的PCB上。

CABLINE-VS 母座:
作为VESA介面标准连接器,并在
PC/Notebook领域市场占有率第一名

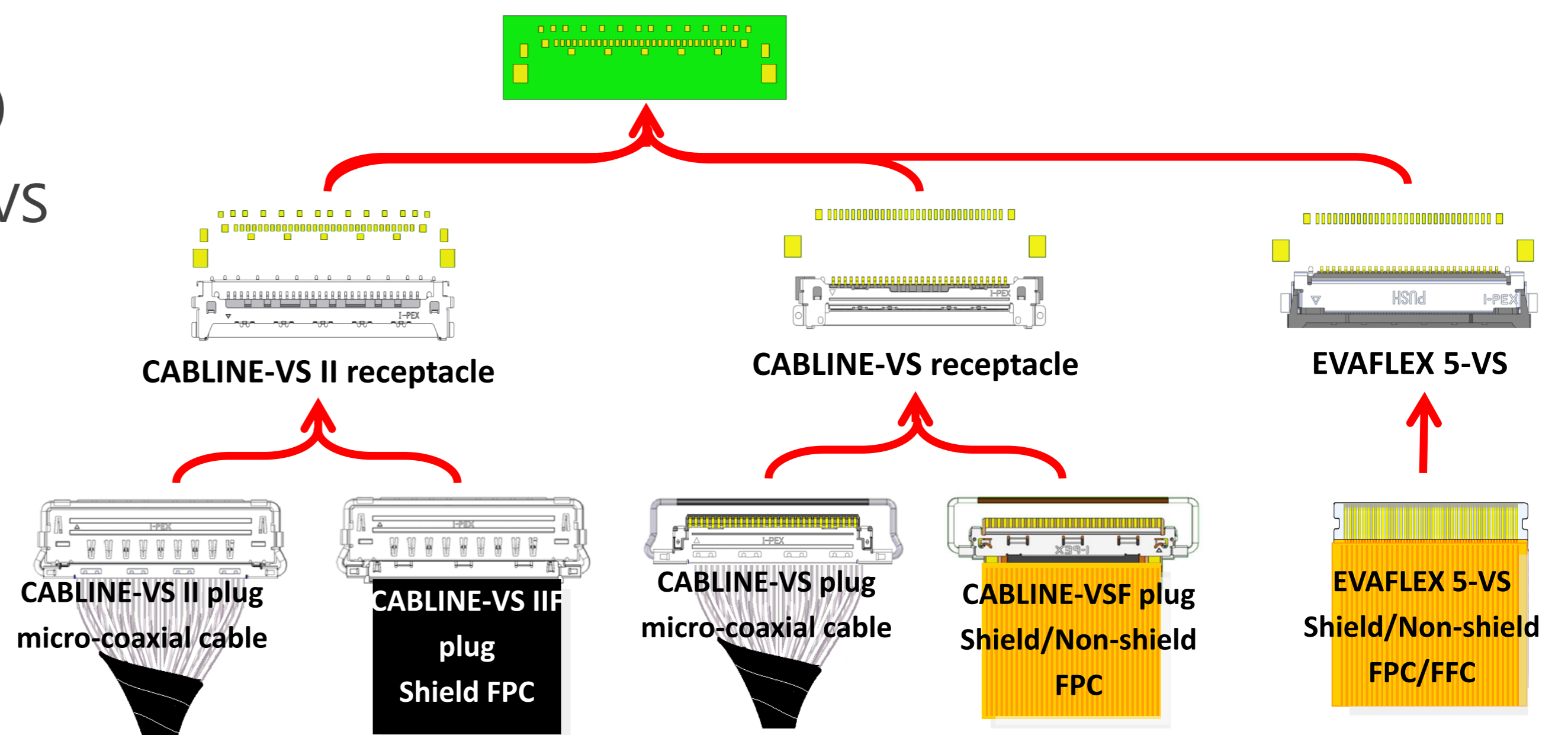

Component Parts Details

Component Parts

Connector parts

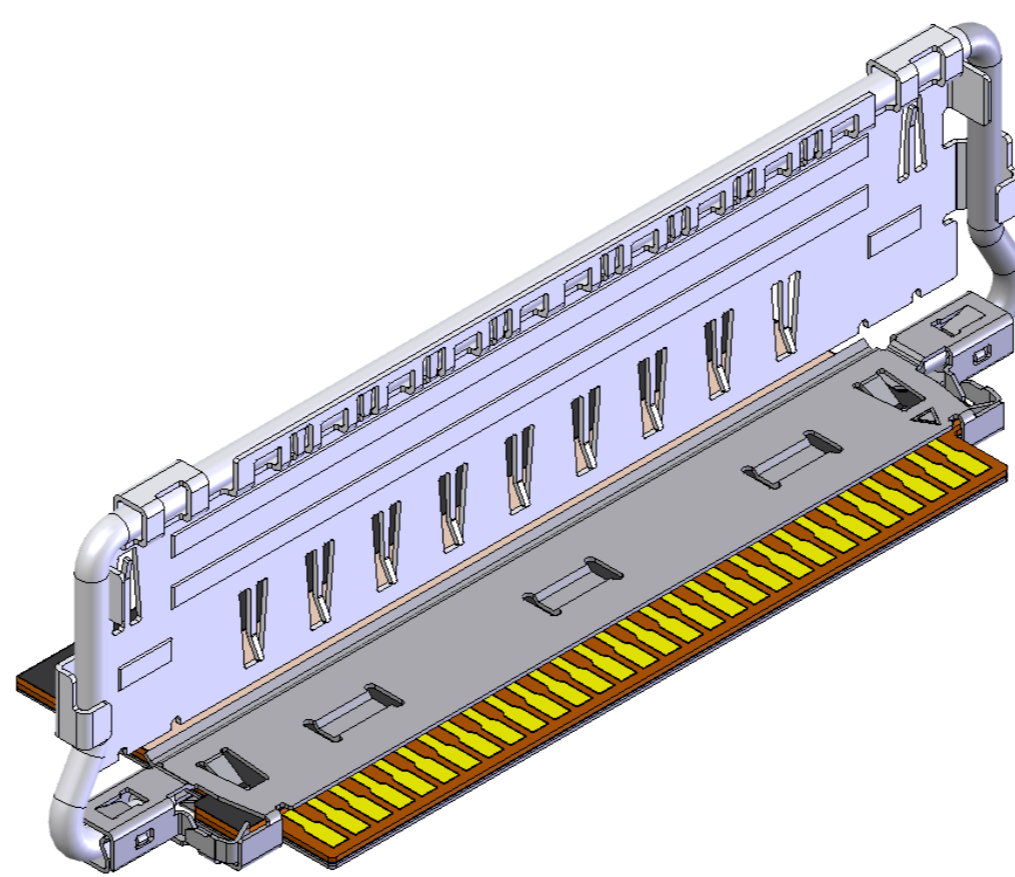

CABLINE-VS IIF PLUG with FPC

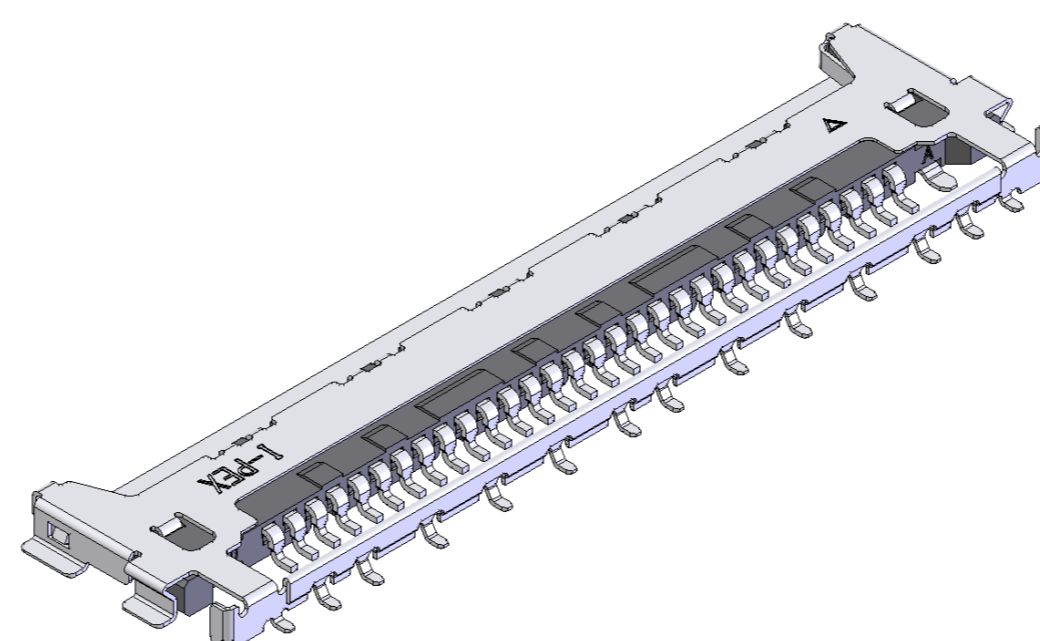

CABLINE-VS II RECEPTACLE

Shell Assembly

Recommended P/N		20862-0**T-01		
PART No.	Pos.	A	B	C
20862-030T-01	30	20.30	17.56	21.85
20862-040T-01	40	25.30	22.56	26.85

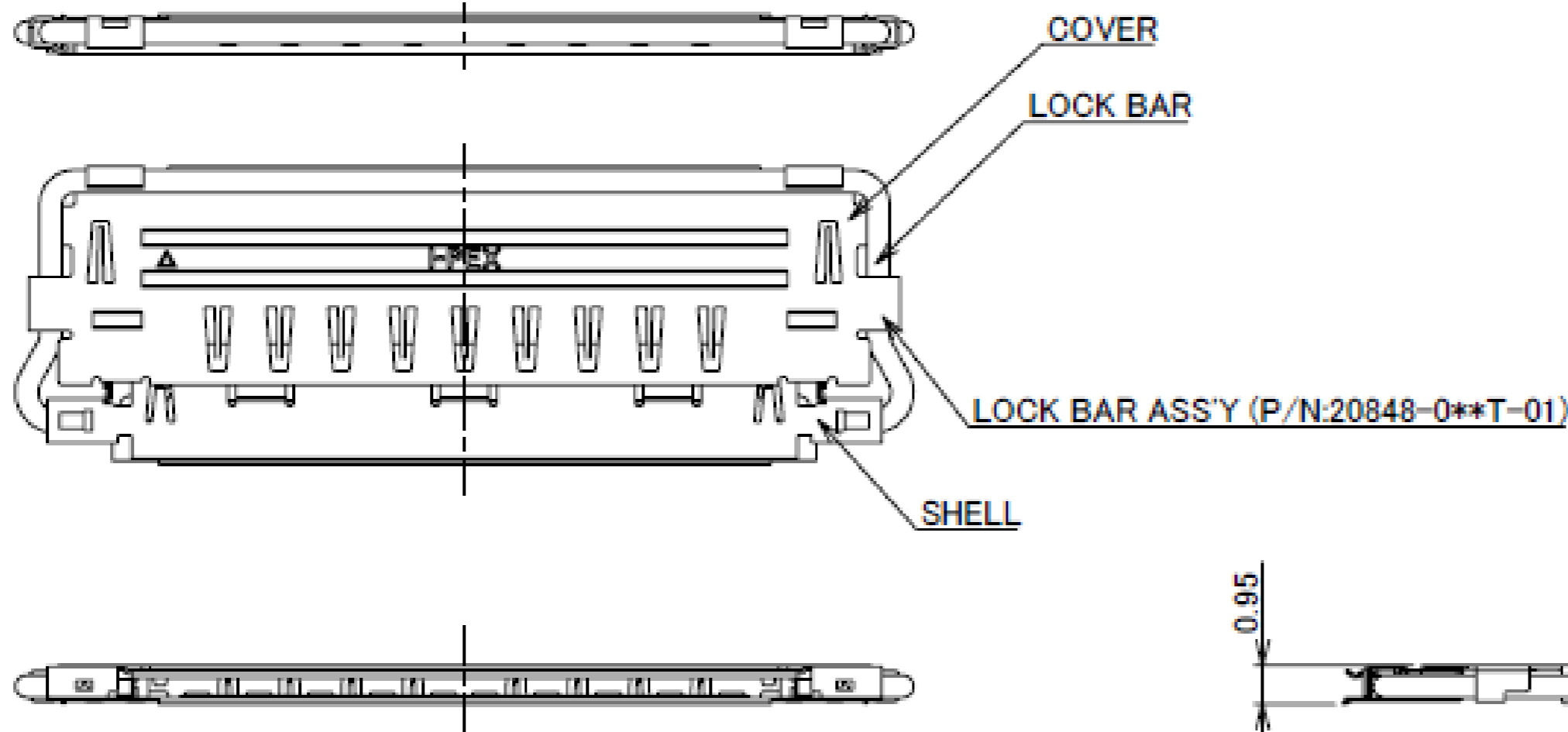
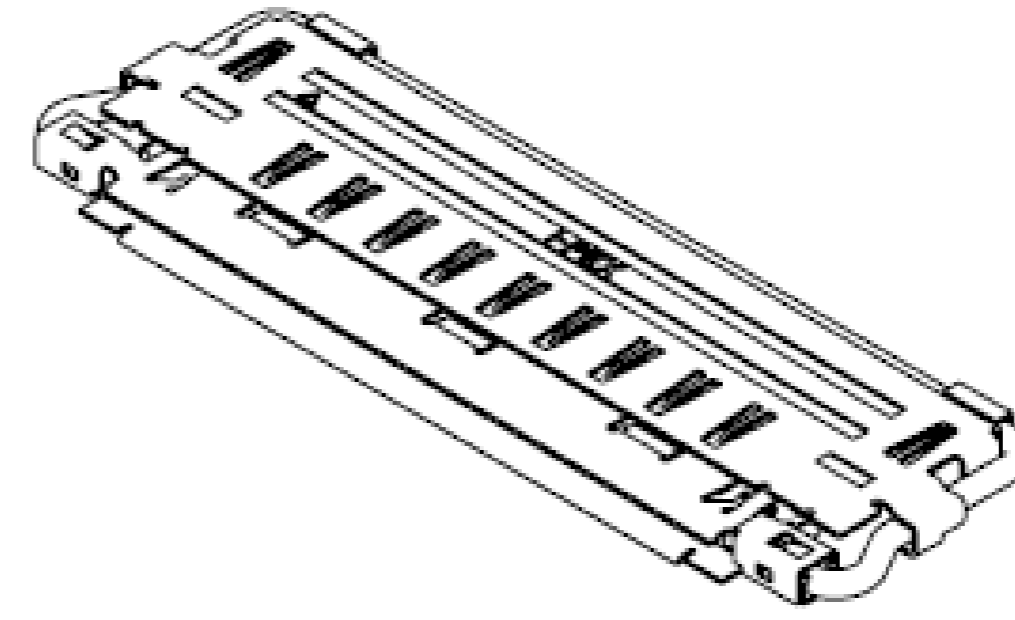
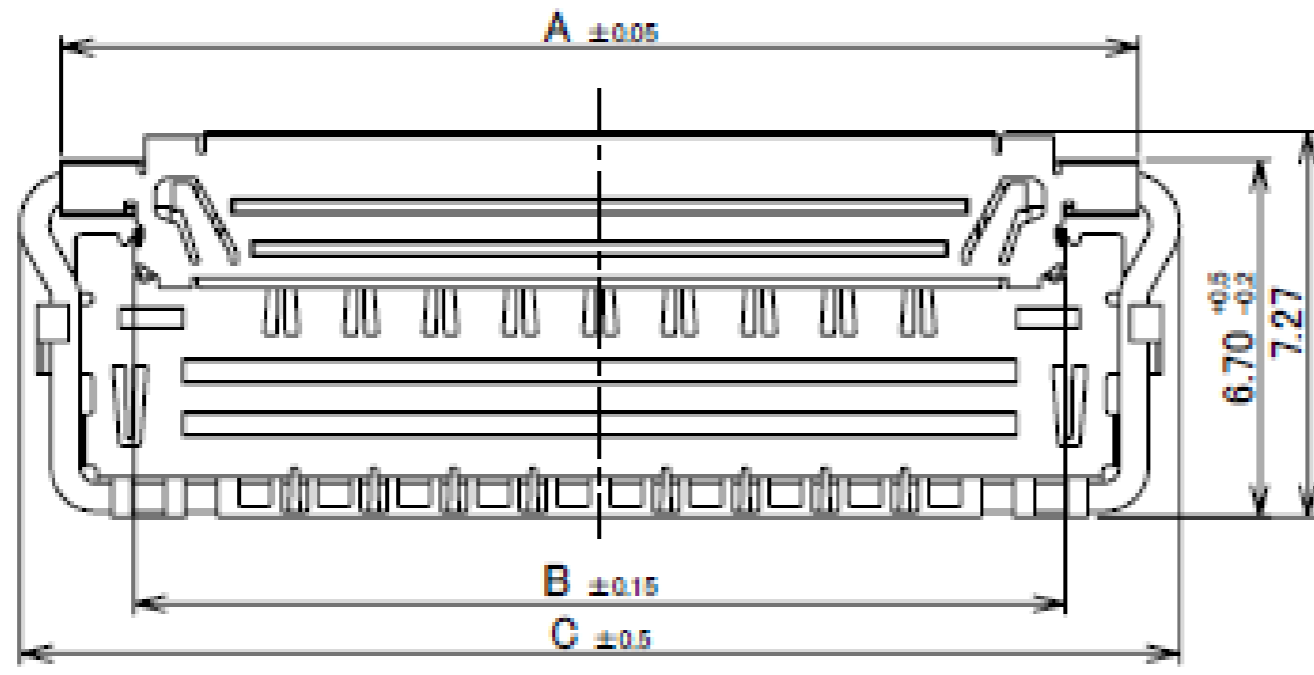
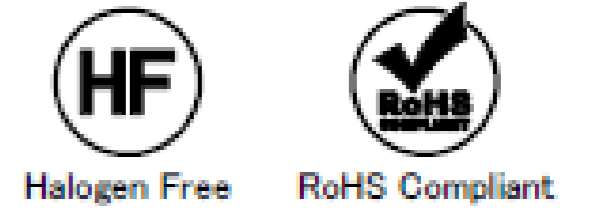

NO.	DISCRIPTION	MATERIAL	FINISH , REMARKS
3	COVER	PHOSPHOR BRONZE	Ni 1.00 μ m MIN.
2	LOCK BAR	STAINLESS STEEL	-
1	SHELL	PHOSPHOR BRONZE	PARTIAL Au 0.003 μ m MIN. OVER Ni 1.00 μ m MIN.

Rev.8

Recommended P/N		20862-0**T-01				
PART No.	Pos.	A	B	C	D	E
20862-030T-01	30	20.30	17.56	21.85	15.50	15.30
20862-040T-01	40	25.30	22.56	26.85	20.50	20.30

FPC ASS'Y STATE COVER CLOSE

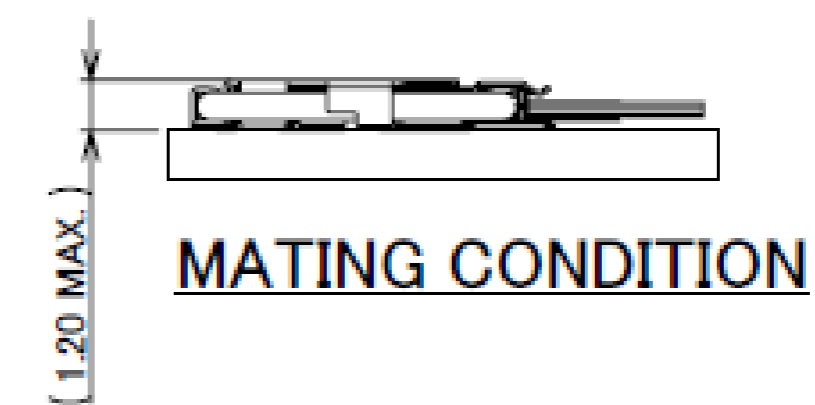
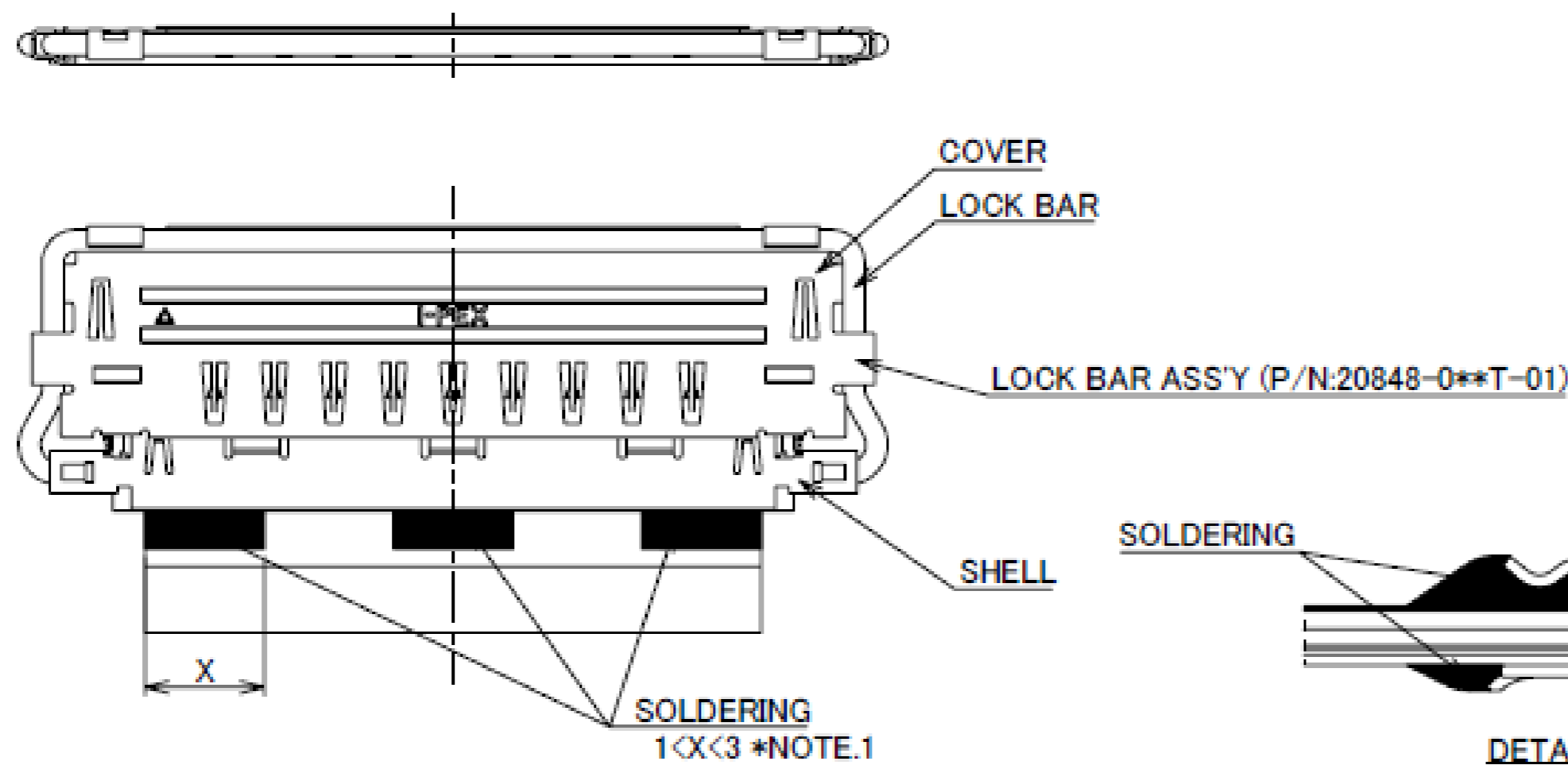
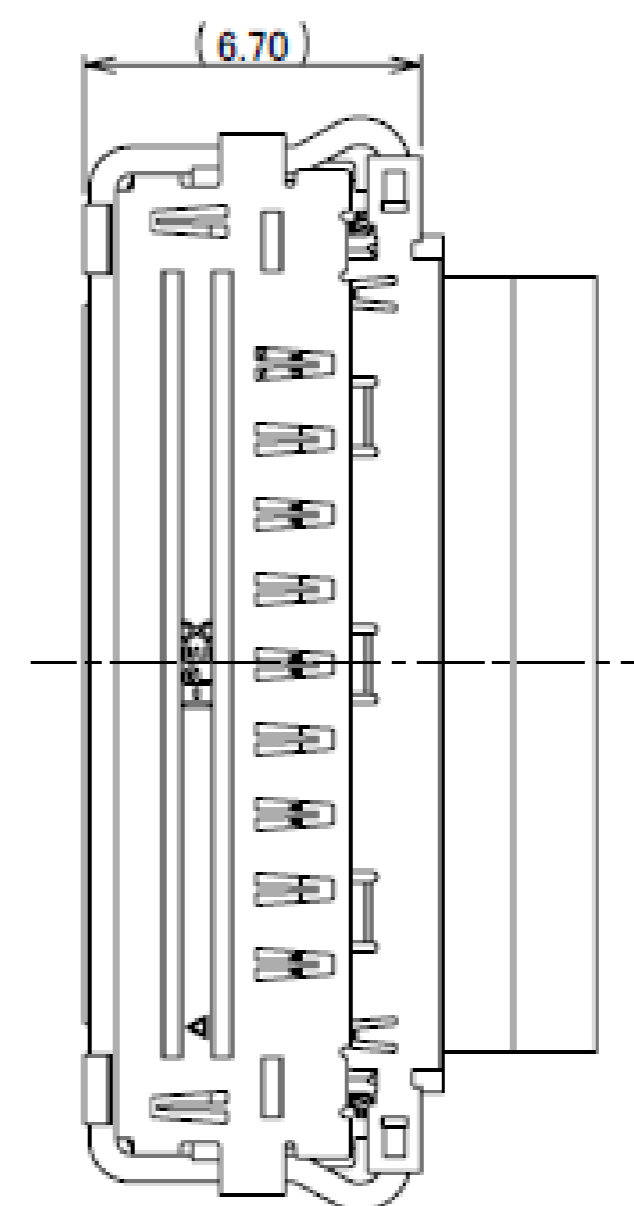
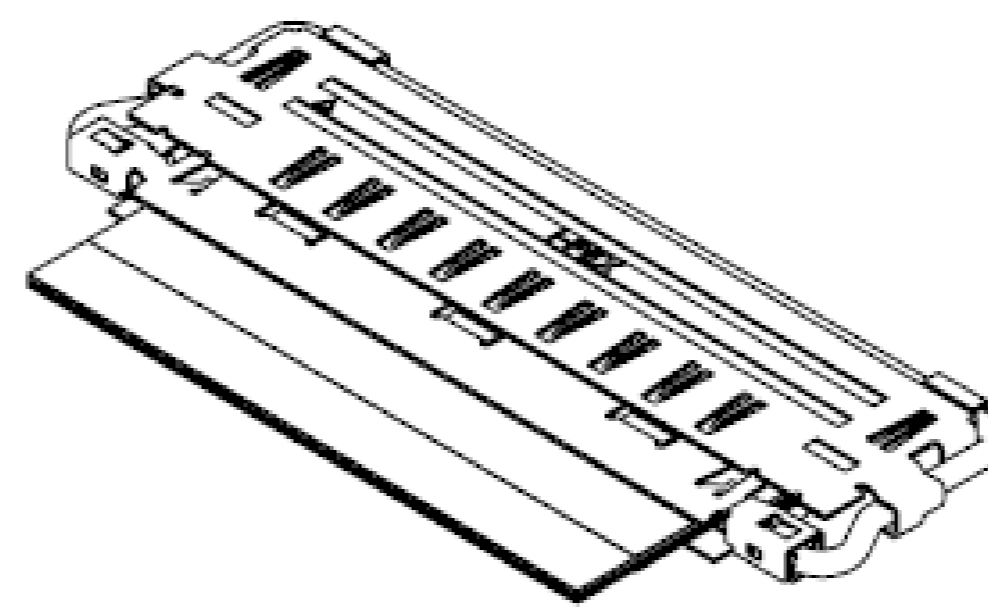
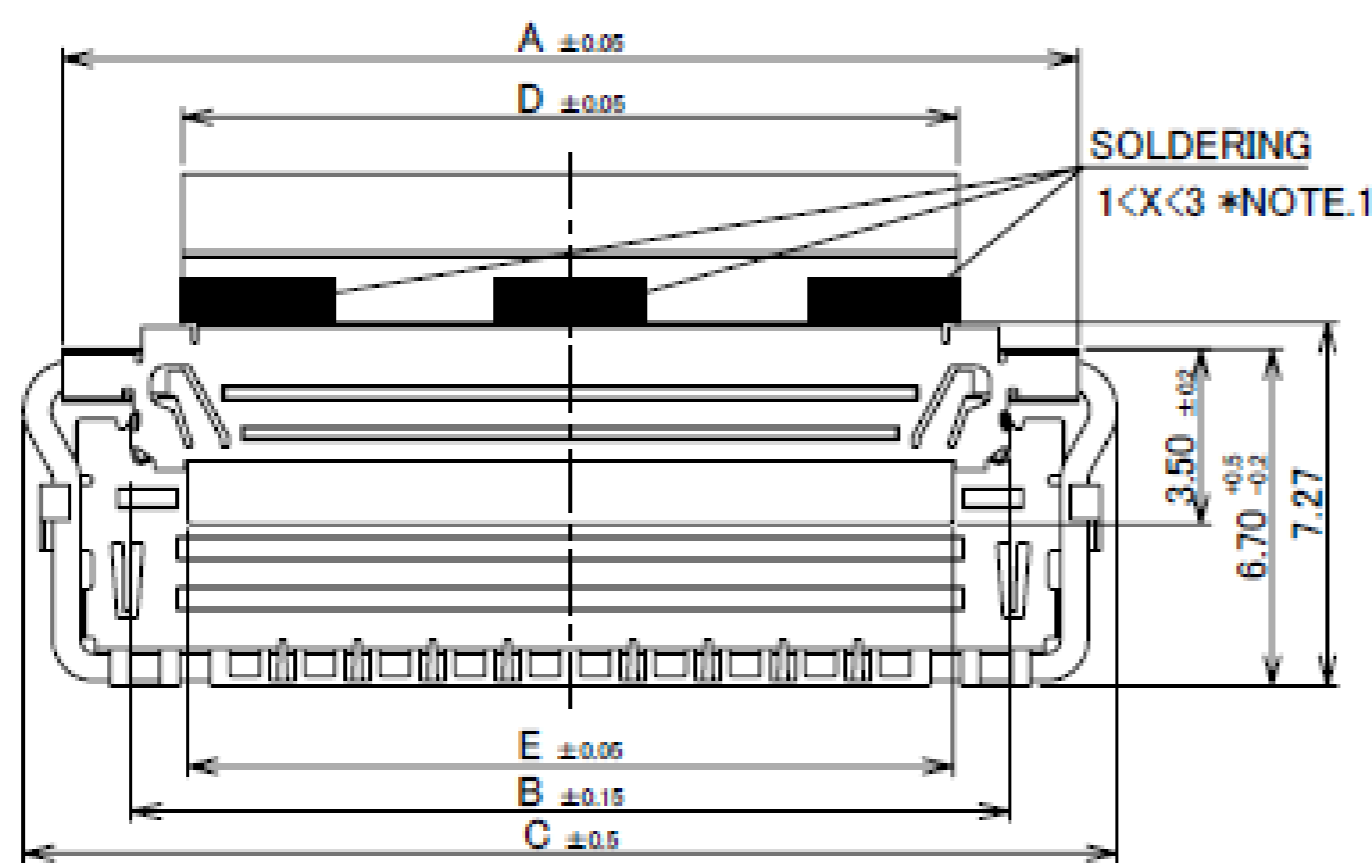

NOTES.
1.Soldering Area X is recommended dimension.
It does not mater if it might be exceed the recommended dimension.

Rev.8

Shell Assembly

Recommended P/N		20862-0**T-01		
PART No.	Pos.	D	E	F
20862-030T-01	30	17.56	15.30	14.50
20862-040T-01	40	22.56	20.30	19.50

FPC ASS'Y STATE COVER OPEN

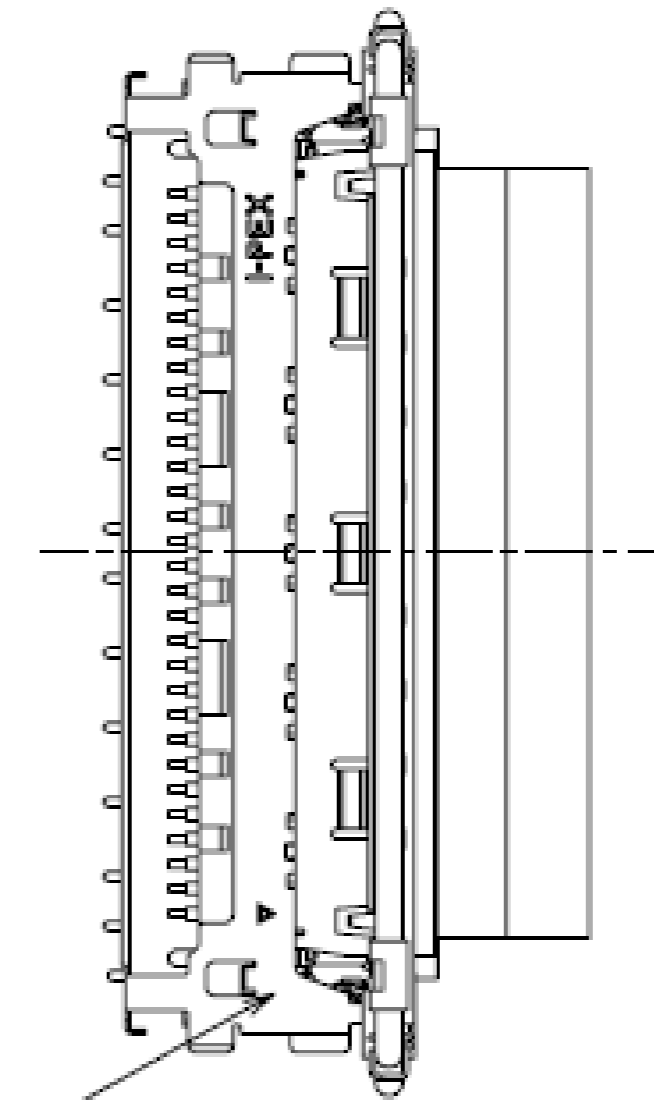
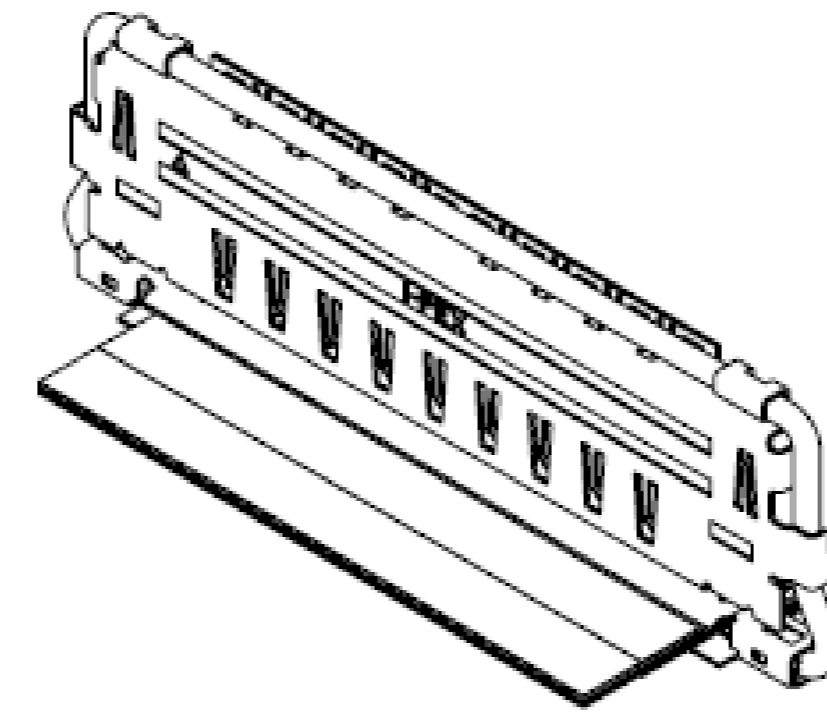
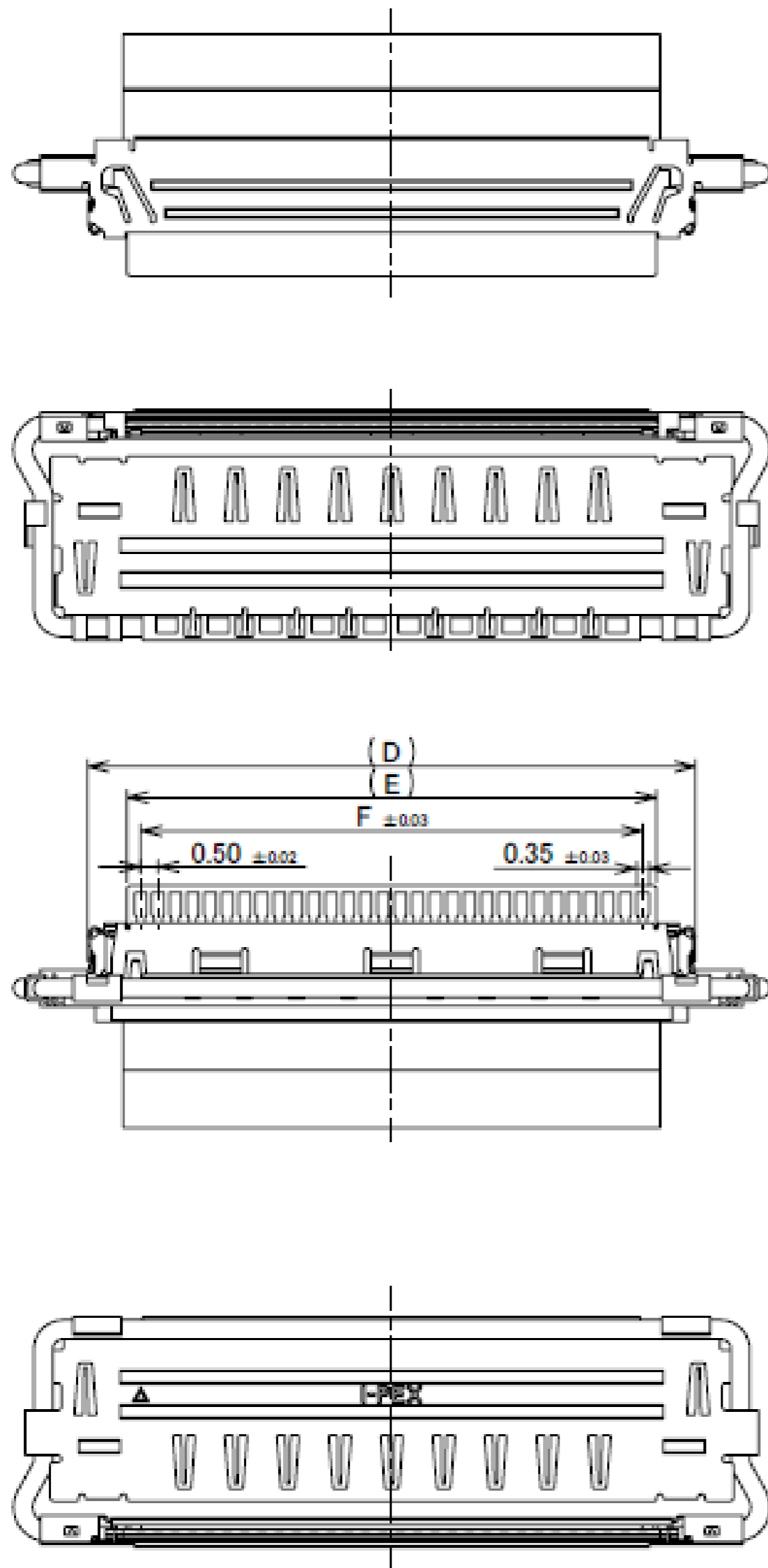

RECE ASS'Y (P/N:20849-0**E-01)

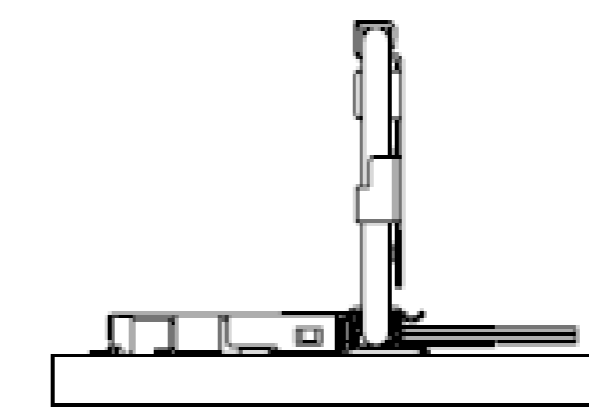

MATING CONDITION

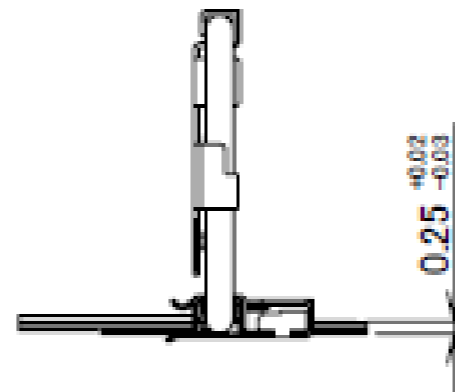

PART No.	Pos.	C	F	G	H
20862-030T-01	30	15.30	14.50	16.56	15.50
20862-040T-01	40	20.30	19.50	21.56	20.50

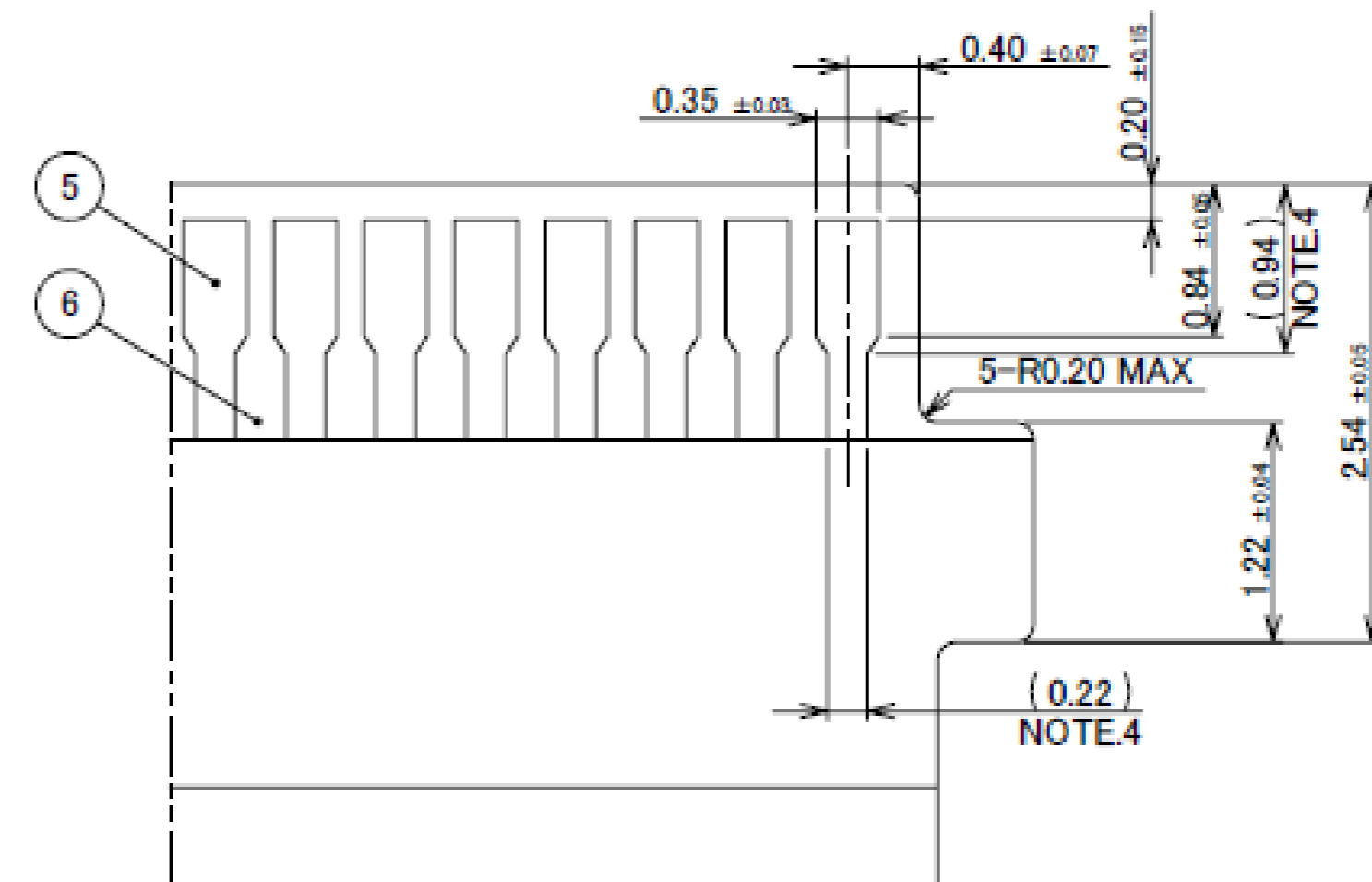
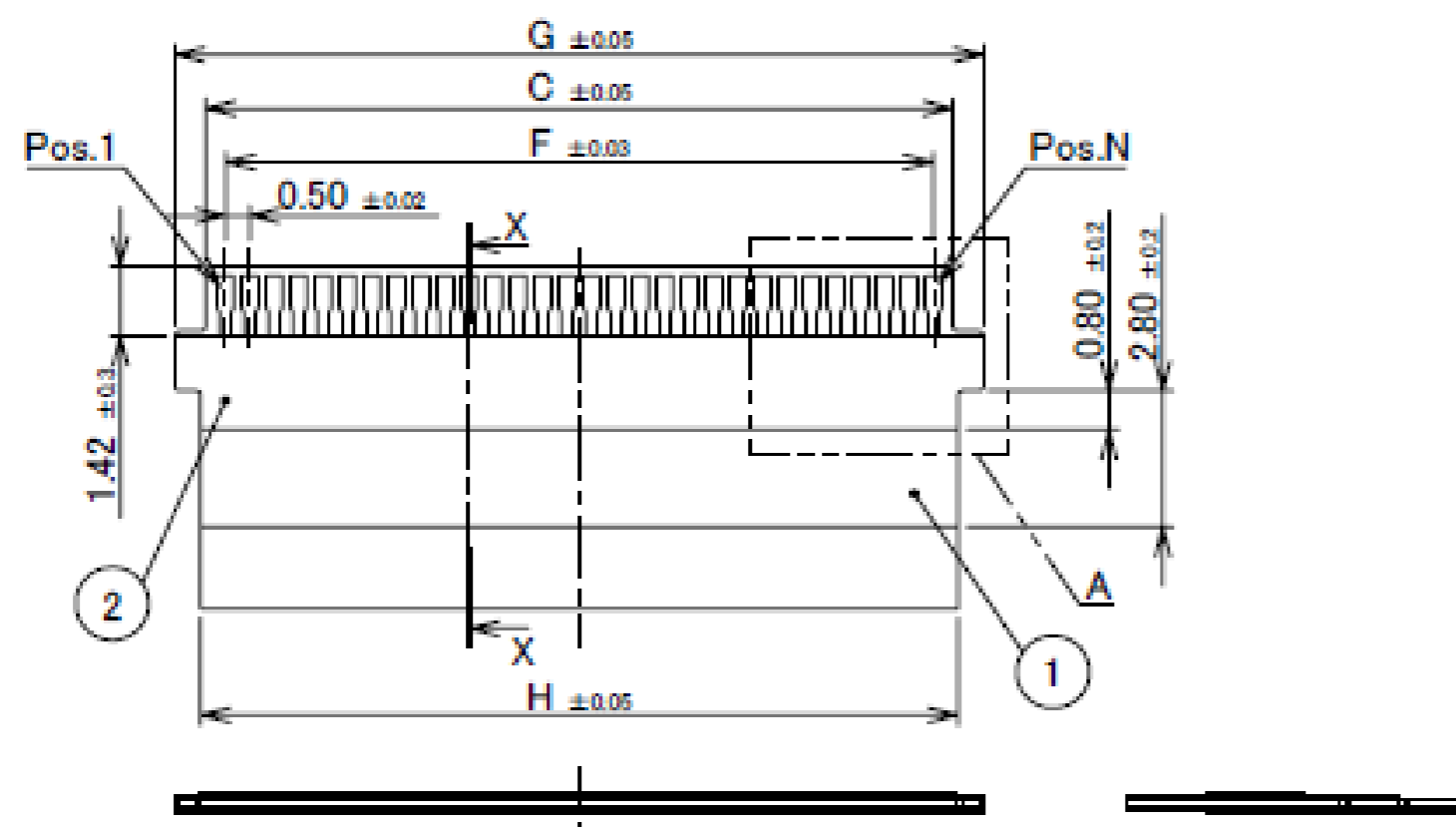

DETAIL A
(S=20/1)

NOTES.

- No.1,3,7,9: CONDUCTOR(GROUND) ARE CARRYING OUT THE ELECTRICAL CONNECTION.
- No.5: SIGNAL Pos. AND No.1,3,7,9: CONDUCTOR(GROUND) ARE NOT CONTACTING.
- No.5: GROUND Pos. AND No.1,3,7,9: CONDUCTOR(GROUND) ARE CARRYING OUT THE ELECTRICAL CONNECTION.
- ADHESIVE SHOULD USE THERMOSETTING.
- NUMBERS WITHIN PARENTHESES ARE ARBITRARY DIMENSIONS. CHANGE DIMENSIONS IN ACCORDANCE WITH CHARACTERISTIC IMPEDANCE VALUE.

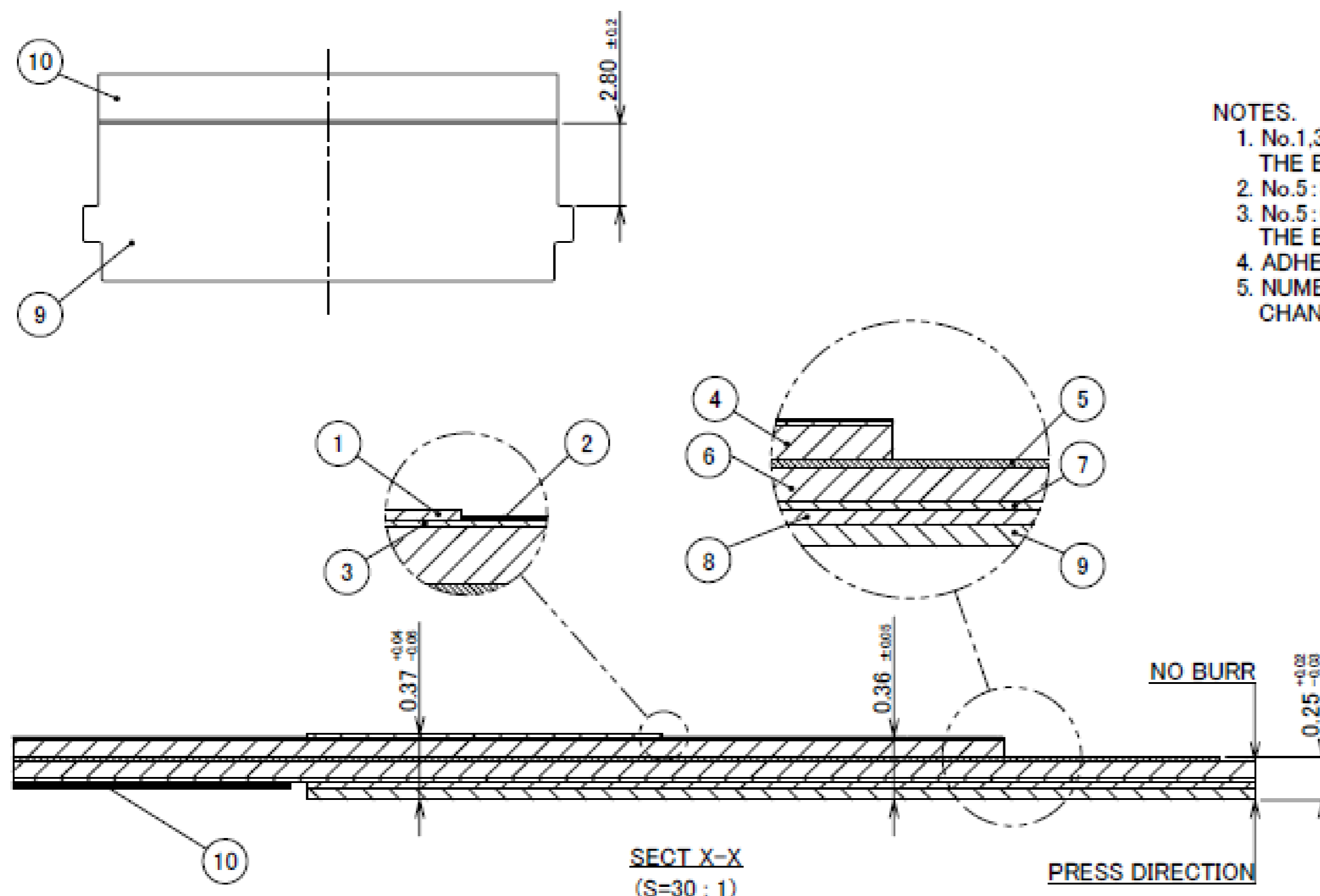

SECT X-X
(S=30 : 1)

PRESS DIRECTION

No.	DESCRIPTION	MATERIAL	PLATING
1	CONDUCTOR(GROUND)	Cu	Ni , Au
2	INSULATOR	-	-
3	CONDUCTOR(GROUND)	Cu	-
4	INSULATOR	-	-
5	CONDUCTOR(SIGNAL,GROUND)	Cu	Ni , Au
6	INSULATOR	-	-
7	CONDUCTOR(GROUND)	Cu	-
8	CONDUCTIVE ADHESIVE	-	-
9	REINFORCING TAPE & CONDUCTOR(GROUND)	SUS	Ni
10	INSULATOR	-	-

Rev.8

Rev.8

Receptacle Assembly

Recommended P/N		20849-0**E-01				
PART NO.	Pos.	A	B	C	D	E
20849-020E-0#	20	11.30	9.50	14.33	15.10	11.91
20849-030E-0#	30	16.30	14.50	19.33	20.10	16.91
20849-040E-0#	40	21.30	19.50	24.33	25.10	21.91

P/N : 20849-0**E-0#
SEE TABLE 1
POS.

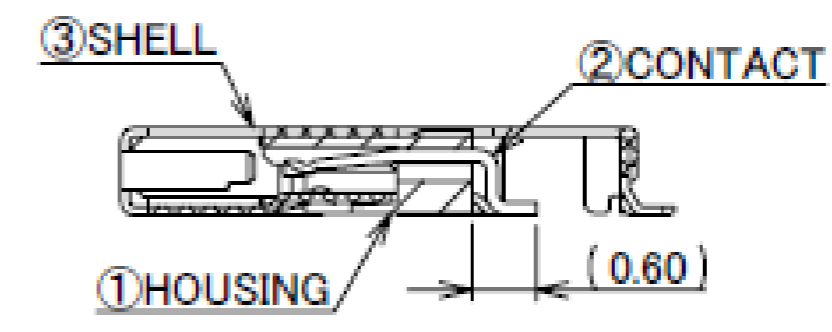

Halogen Free RoHS Compliant

SECT. W-W
(S = 10 : 1)

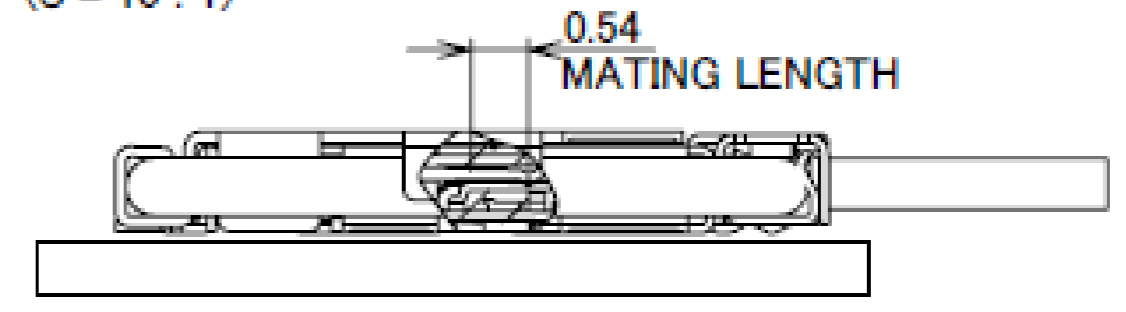

MATING CONDITION
(S = 10 : 1)

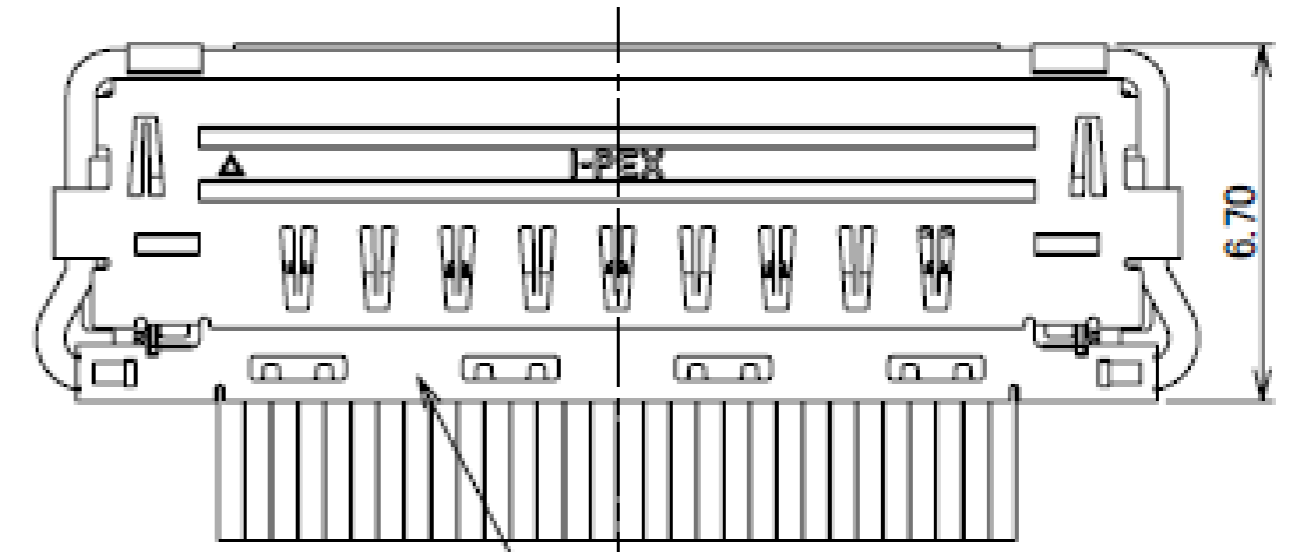

MATING CONDITION

PLUG P/N : 20846-0**T-0#

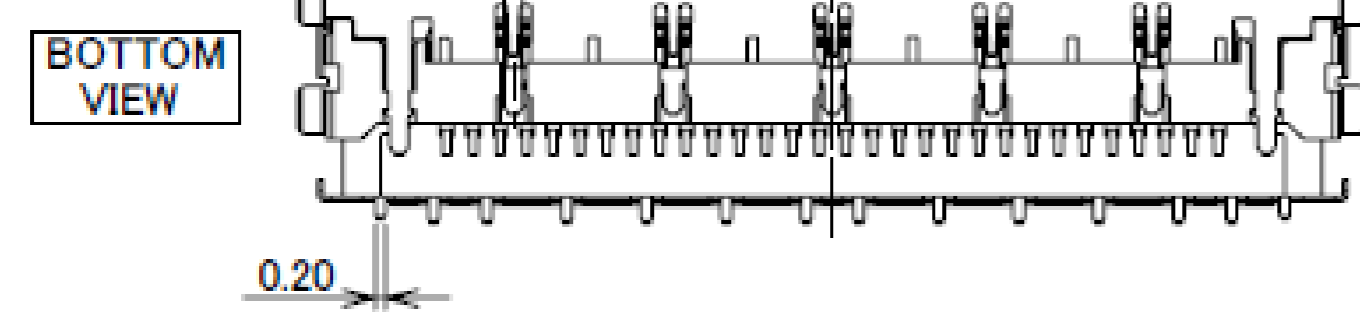
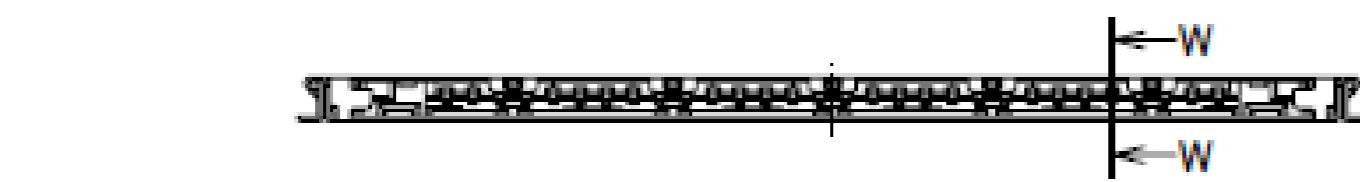
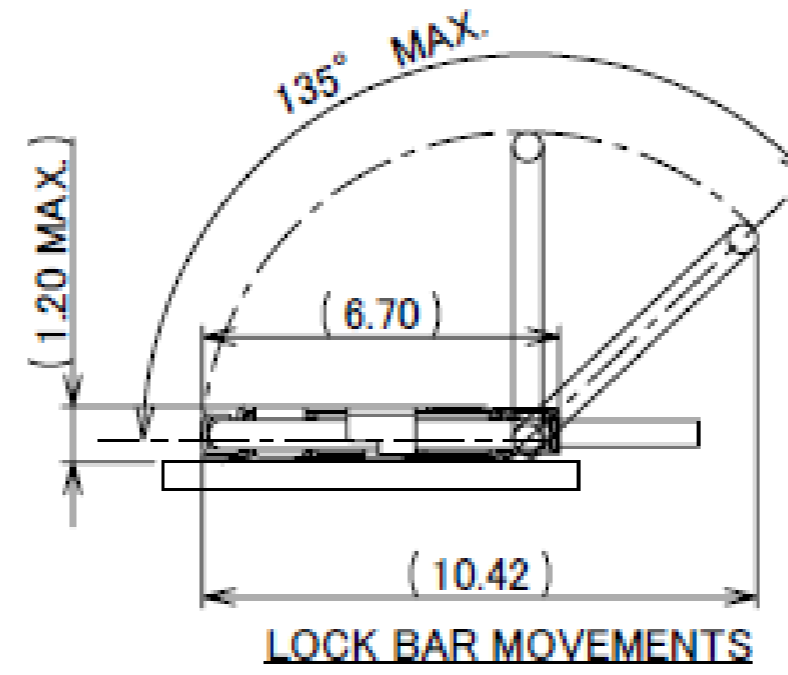
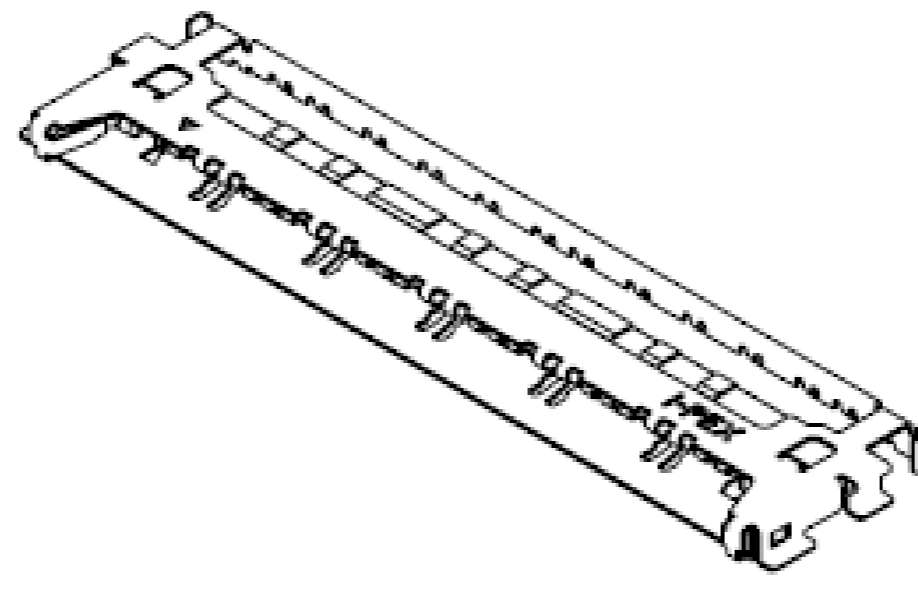
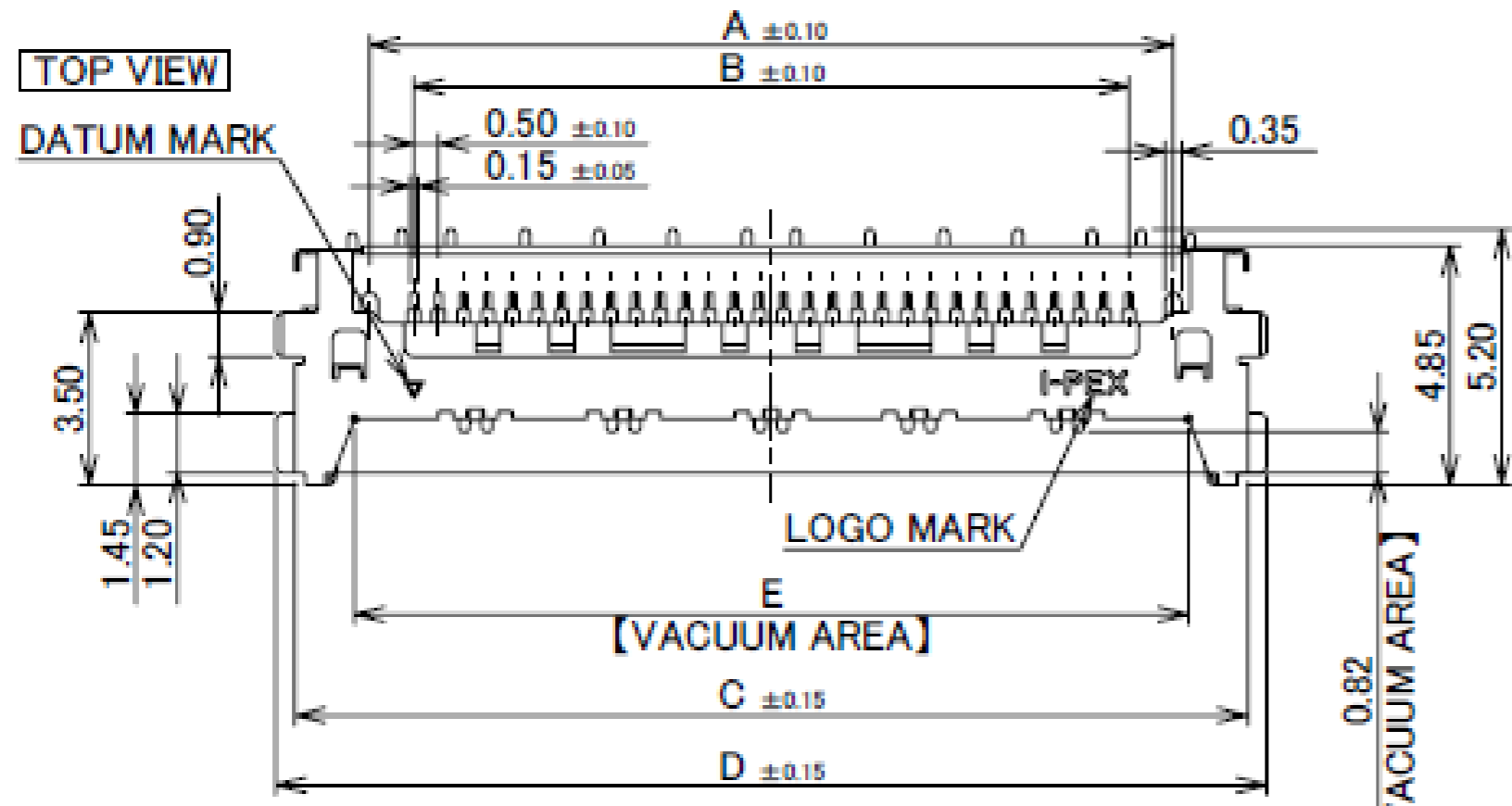
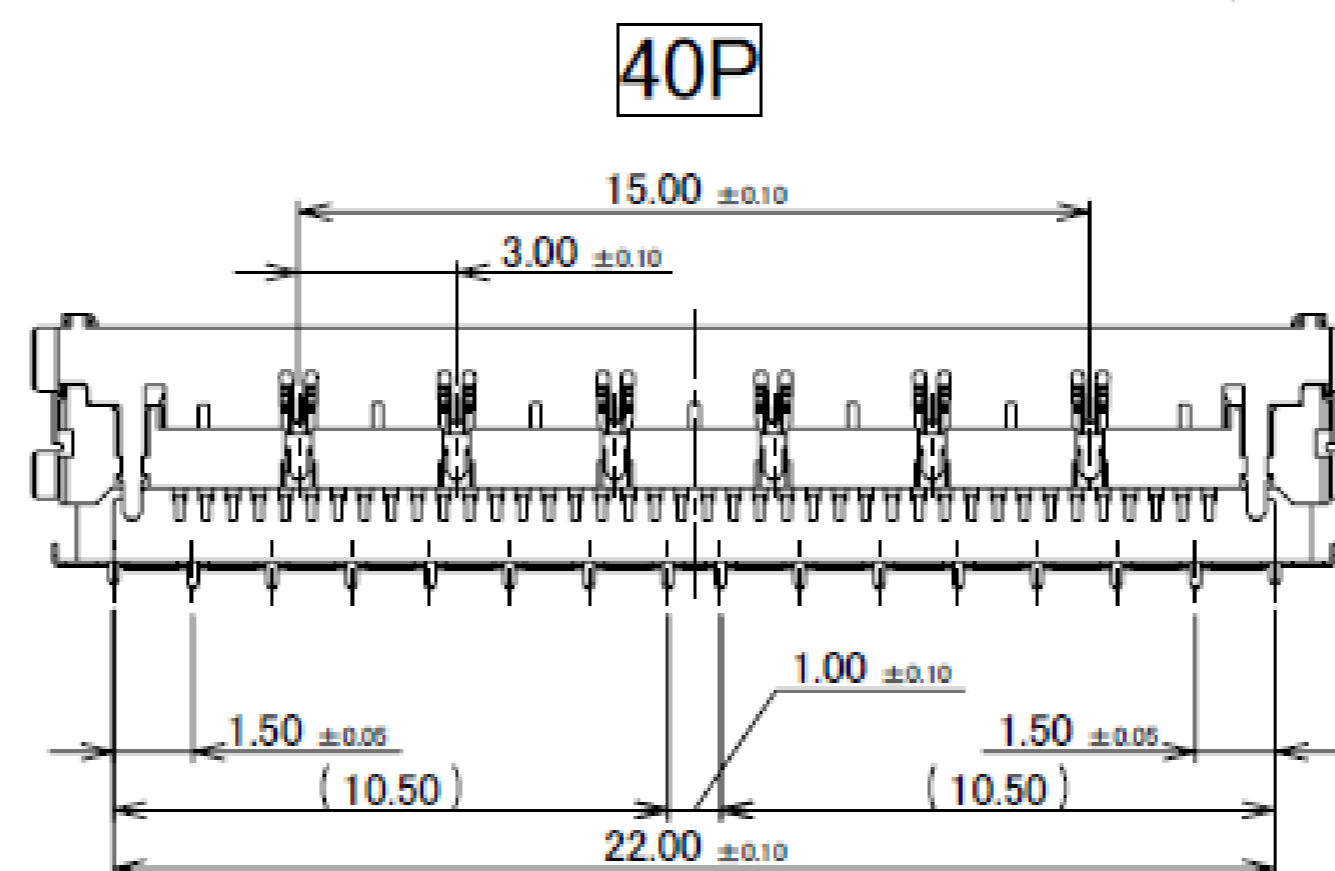
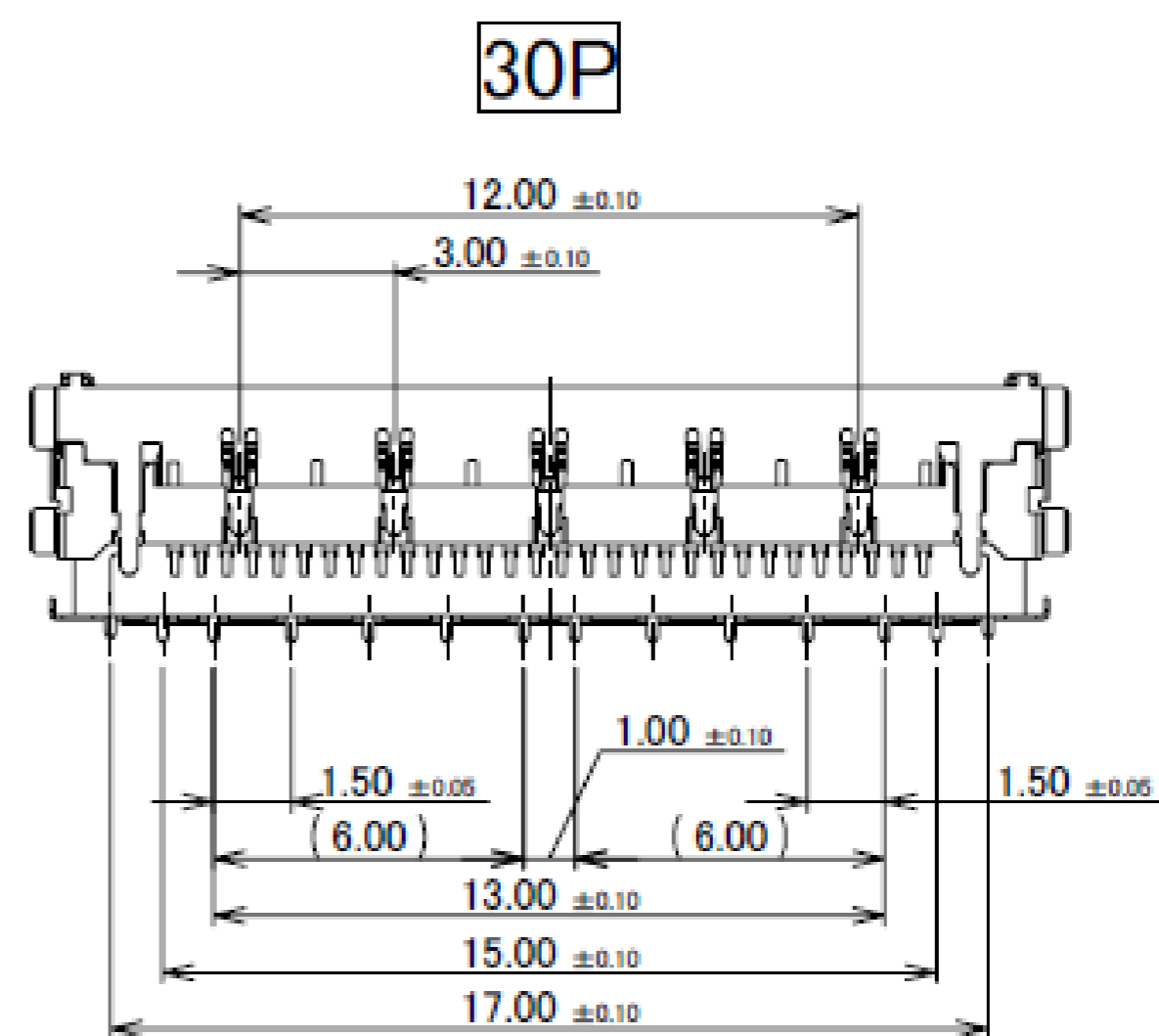
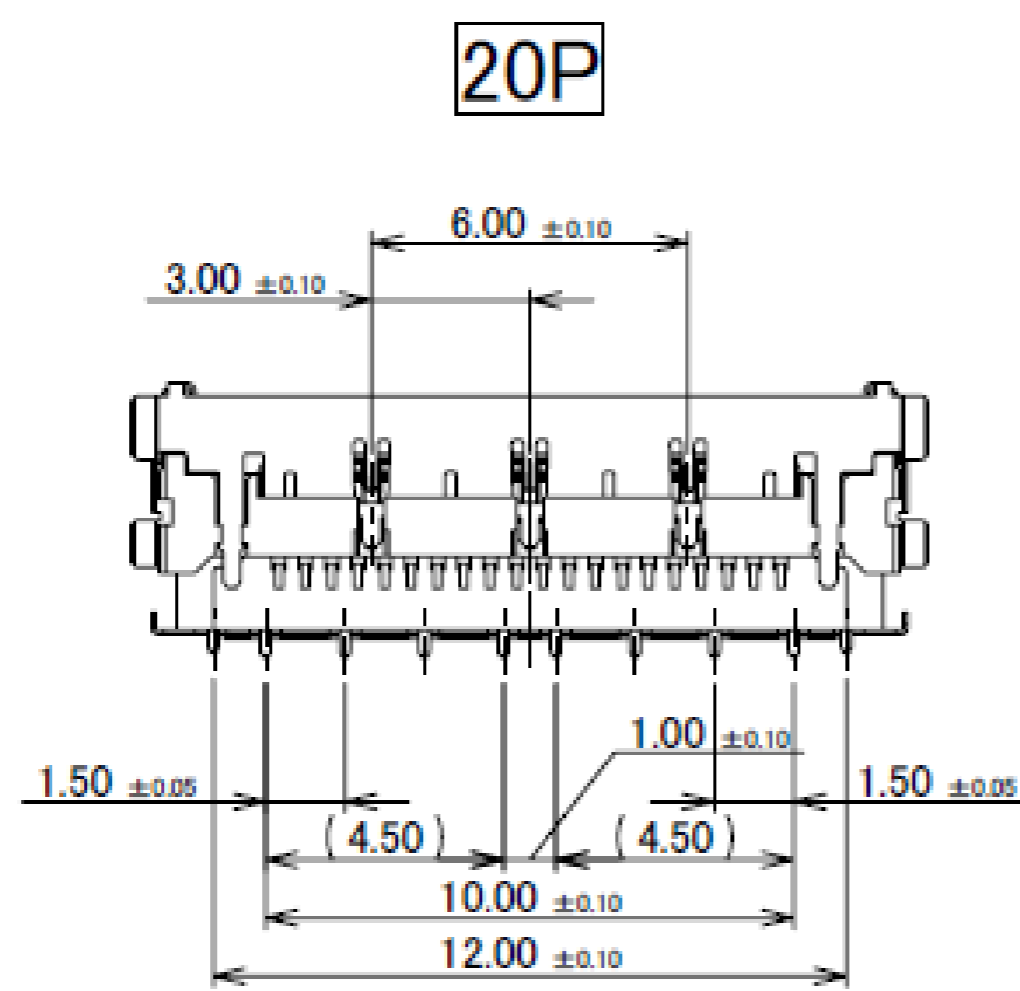

TABLE 1

PART NO.	CONTACT FINISH	SHELL FINISH	
20849-0**E-01	CONTACT & SOLDERING AREA : Au 0.03 μm MIN. OVER Ni 1.00 μm MIN.	ALL OVER Ni 1.00 μm MIN. SOLDERING AREA : Au 0.02 μm MIN.	
20849-0**E-02	CONTACT AREA : Au 0.38 μm MIN. OVER Ni 1.27 μm MIN. SOLDERING AREA : Au 0.03 μm MIN. OVER Ni 1.00 μm MIN.		
3 SHELL	PHOSPHOR BRONZE	SEE TABLE 1	
2 CONTACT	PHOSPHOR BRONZE	SEE TABLE 1	
1 HOUSING	LCP	UL94V-0, BLACK	
NO.	DISCRIPTION	MATERIAL	FINISH, REMARKS

PART NO.	Pos.
20849-020E-0#	20
20849-030E-0#	30
20849-040E-0#	40

BOTTOM VIEW



Rev.10

Rev.10

Receptacle Assembly

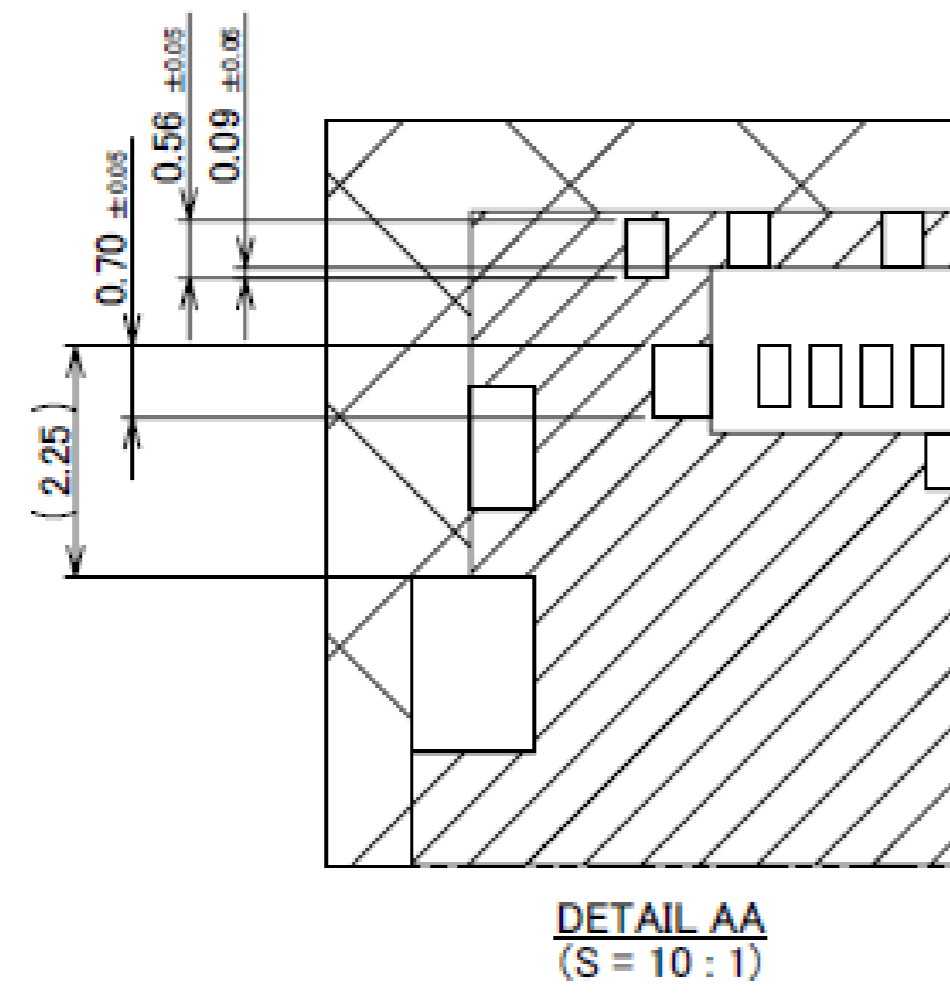
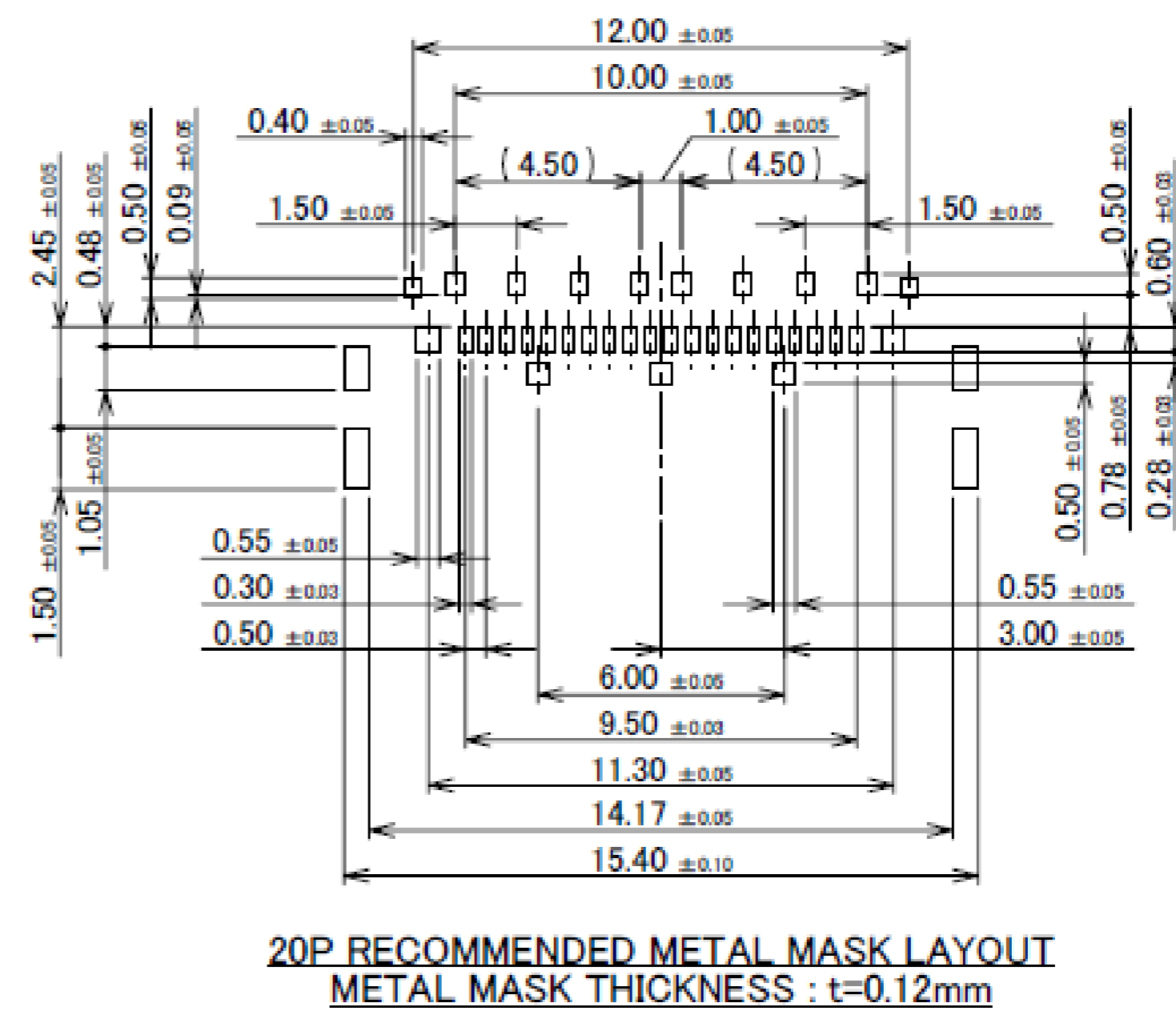
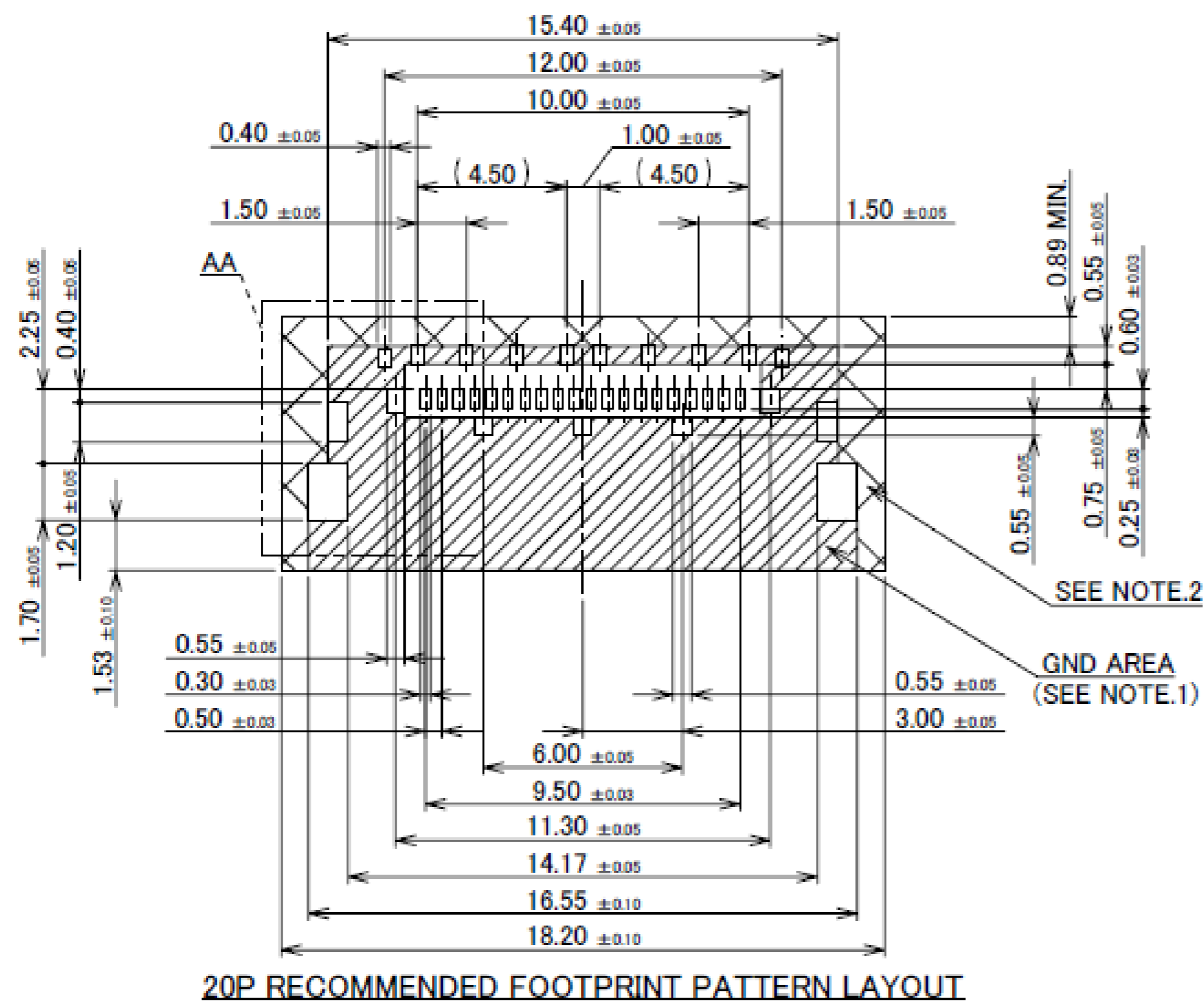

- NOTES.
1. SOLDER RESIST MUST BE APPLIED TO THIS AREA.
 2. DO NOT MOUNT ANOTHER COMPONENT IN THIS AREA.

Rev.10

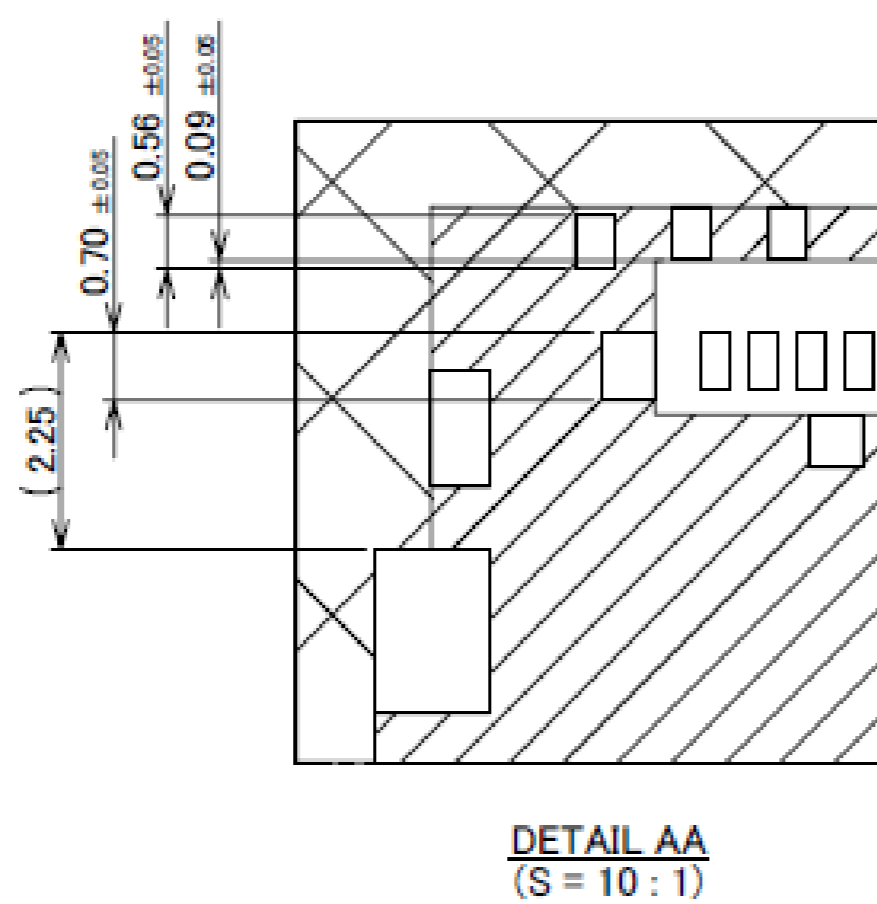
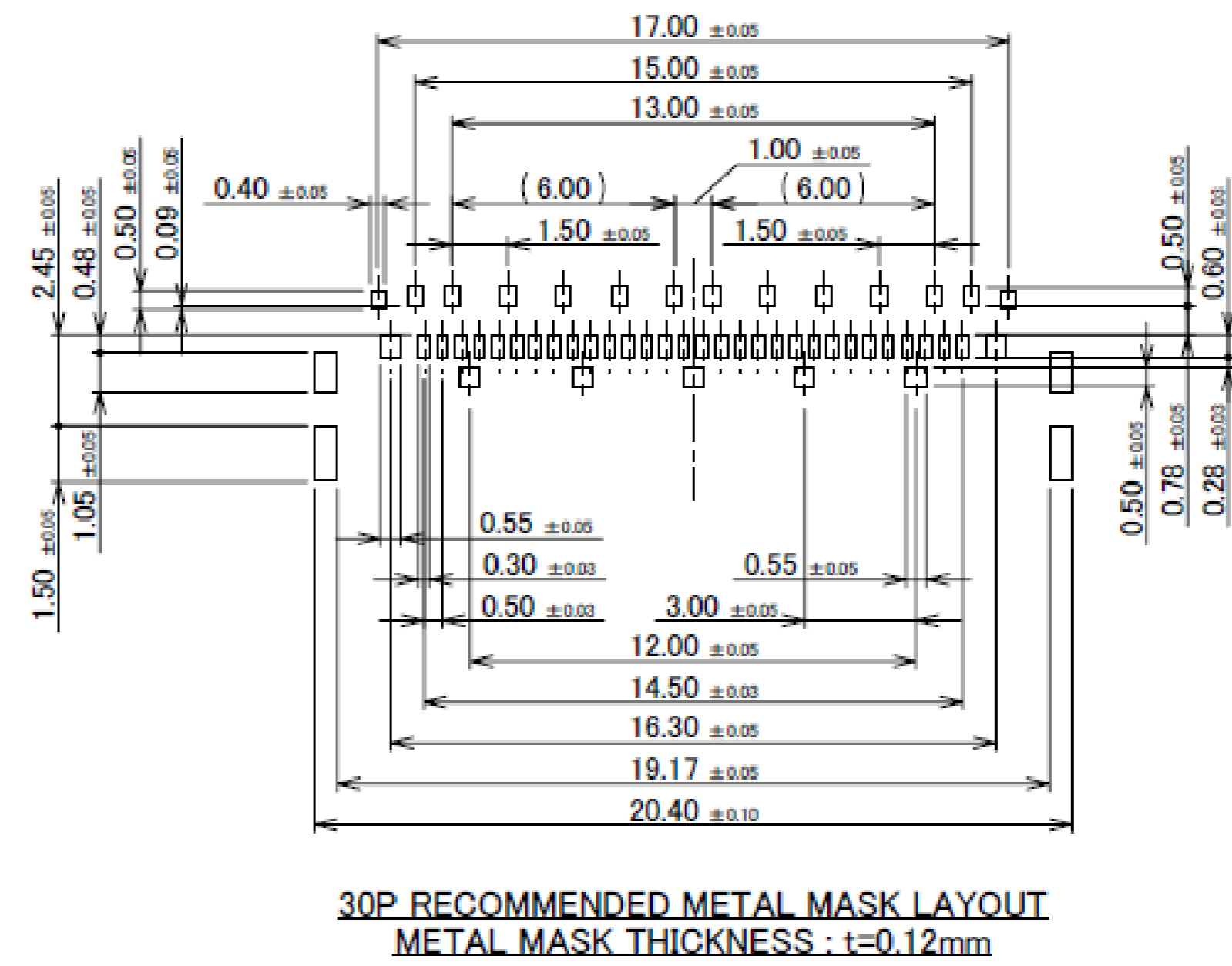
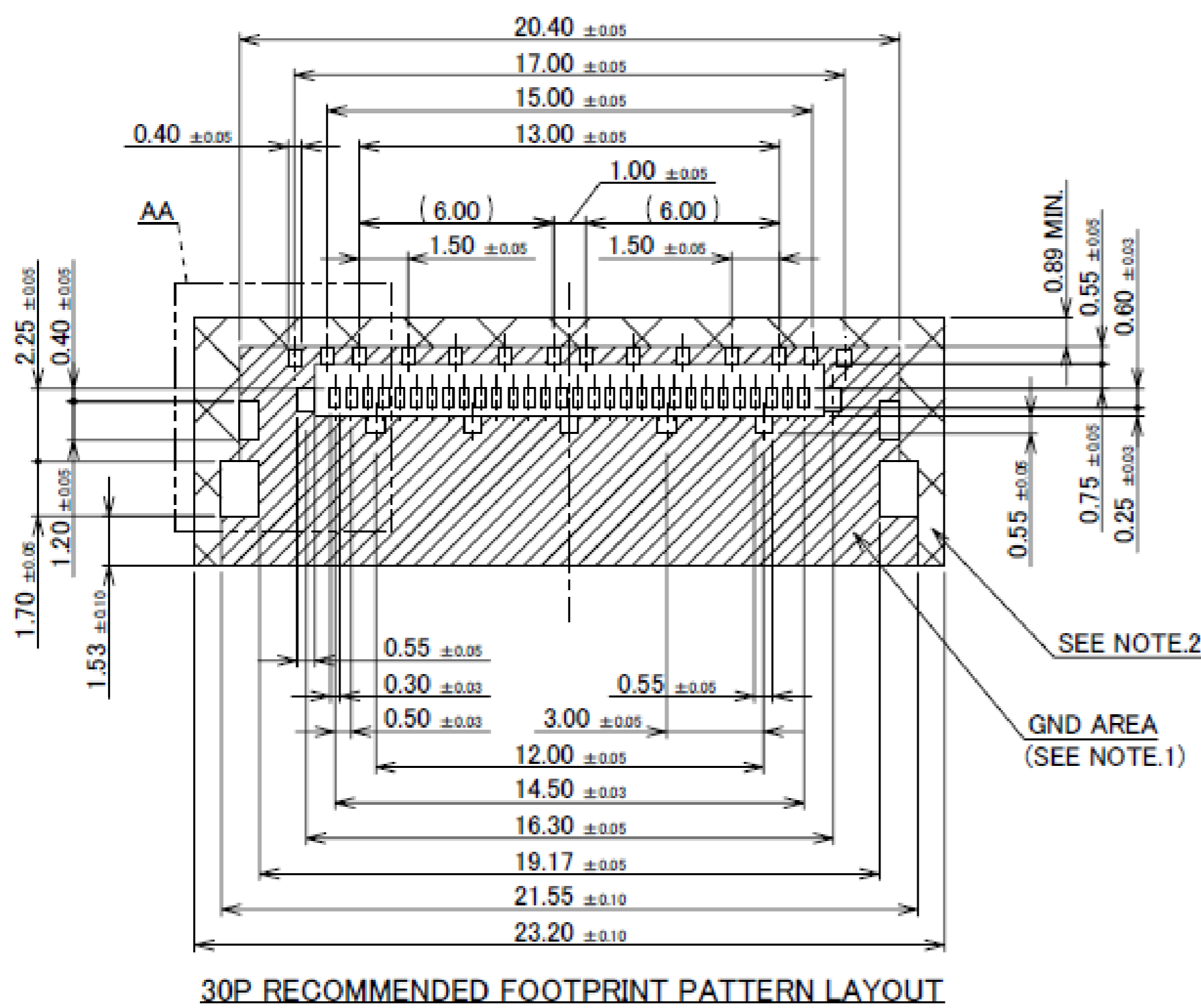

- NOTES.
1. SOLDER RESIST MUST BE APPLIED TO THIS AREA.
 2. DO NOT MOUNT ANOTHER COMPONENT IN THIS AREA.

Rev.10

Receptacle Assembly

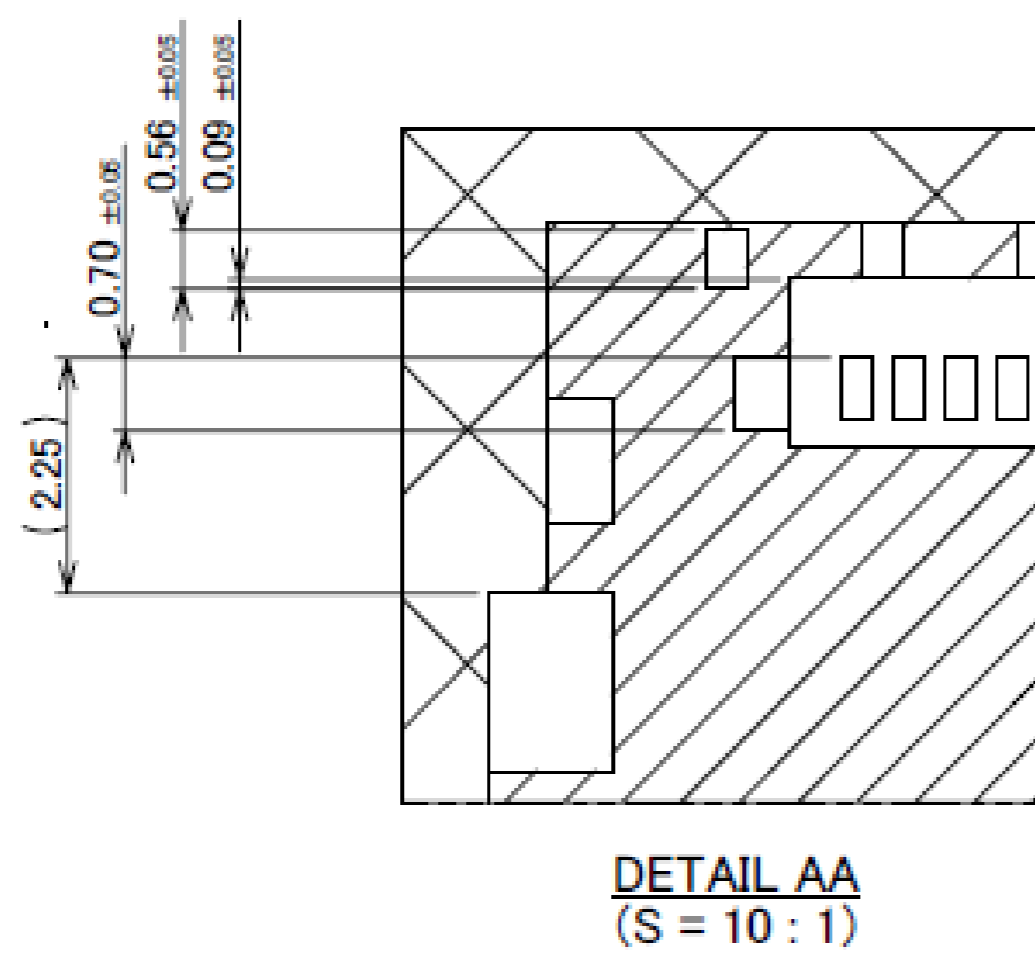
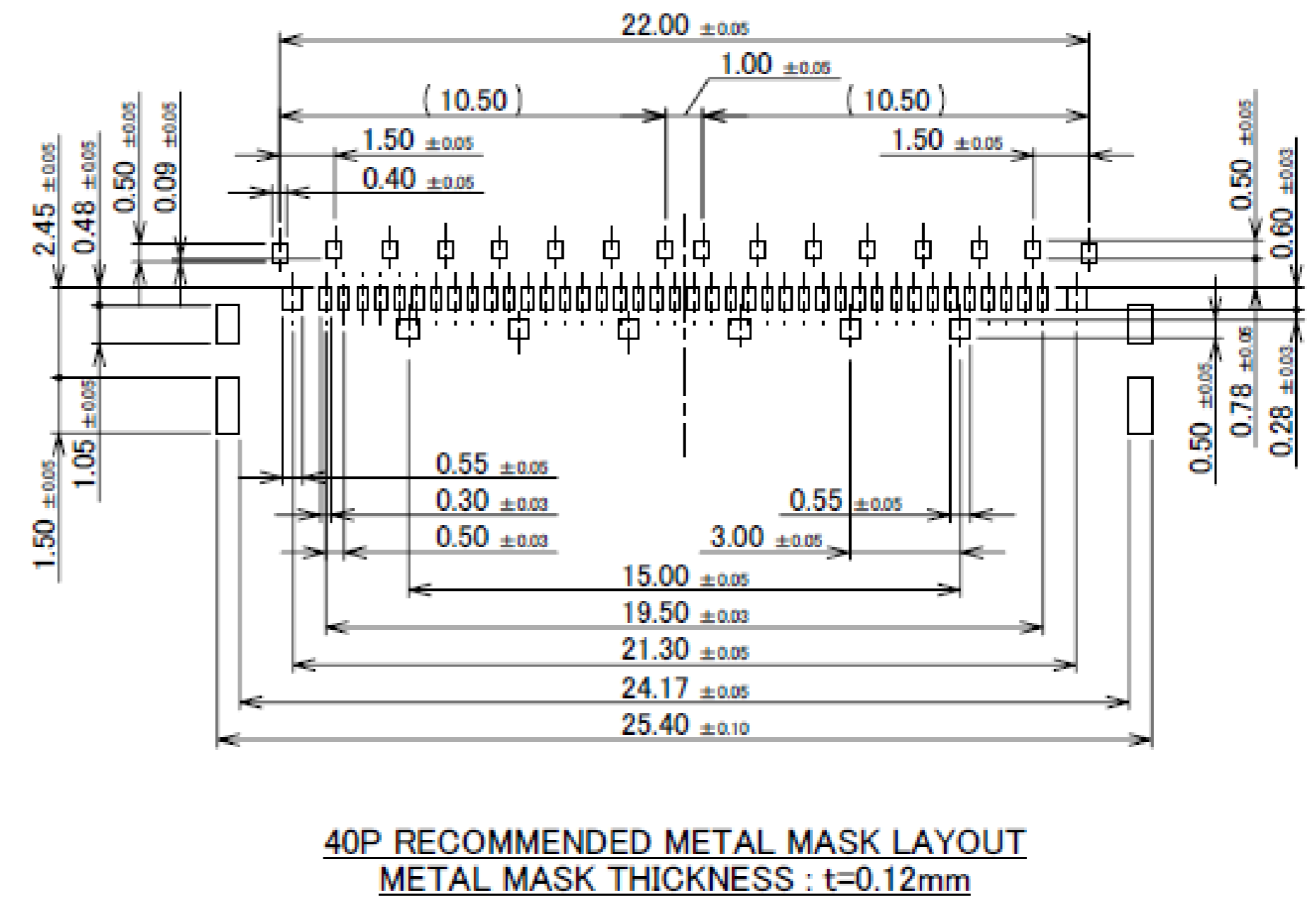
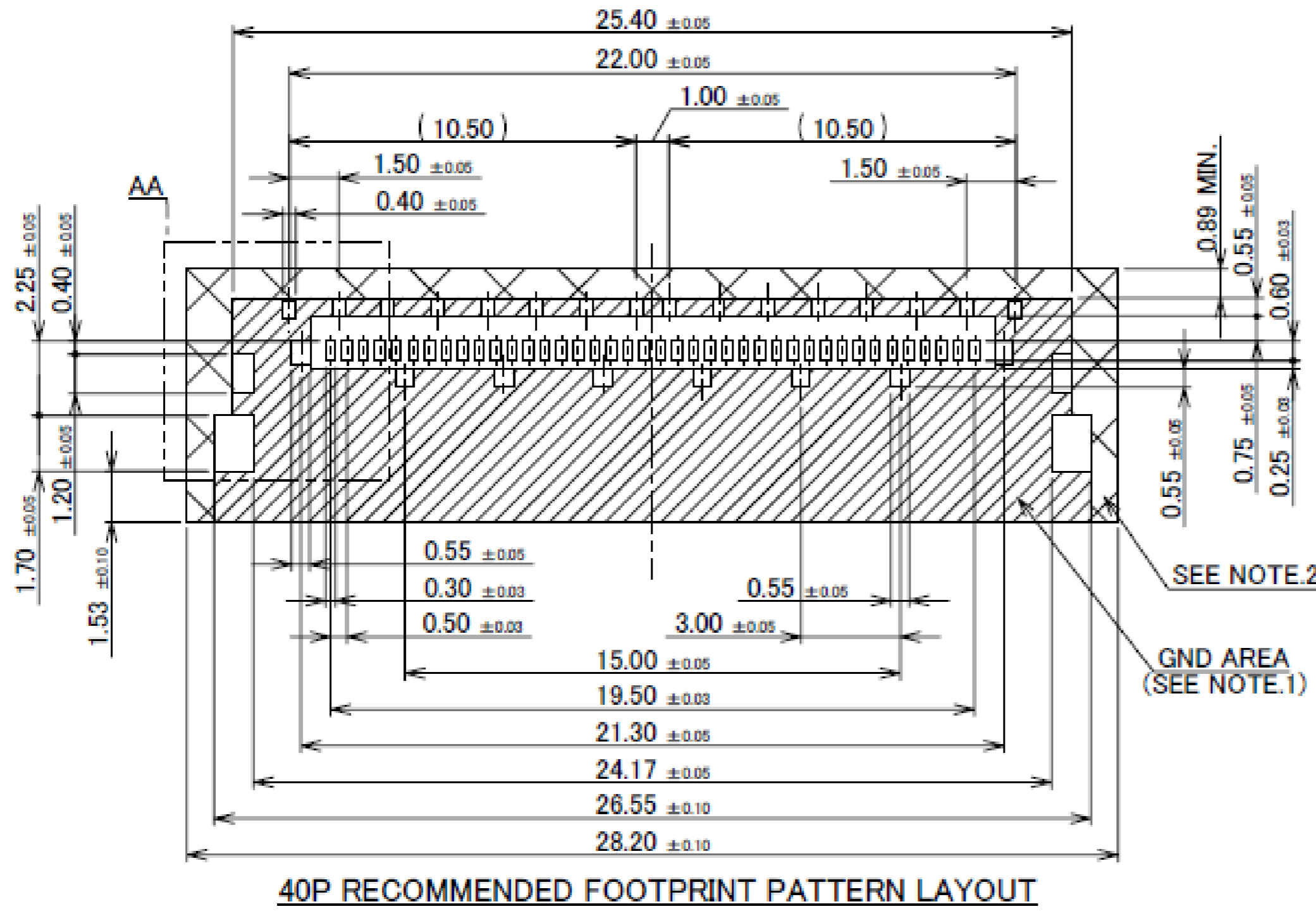

- NOTES.
1. SOLDER RESIST MUST BE APPLIED TO THIS AREA.
2. DO NOT MOUNT ANOTHER COMPONENT IN THIS AREA.

Rev.10

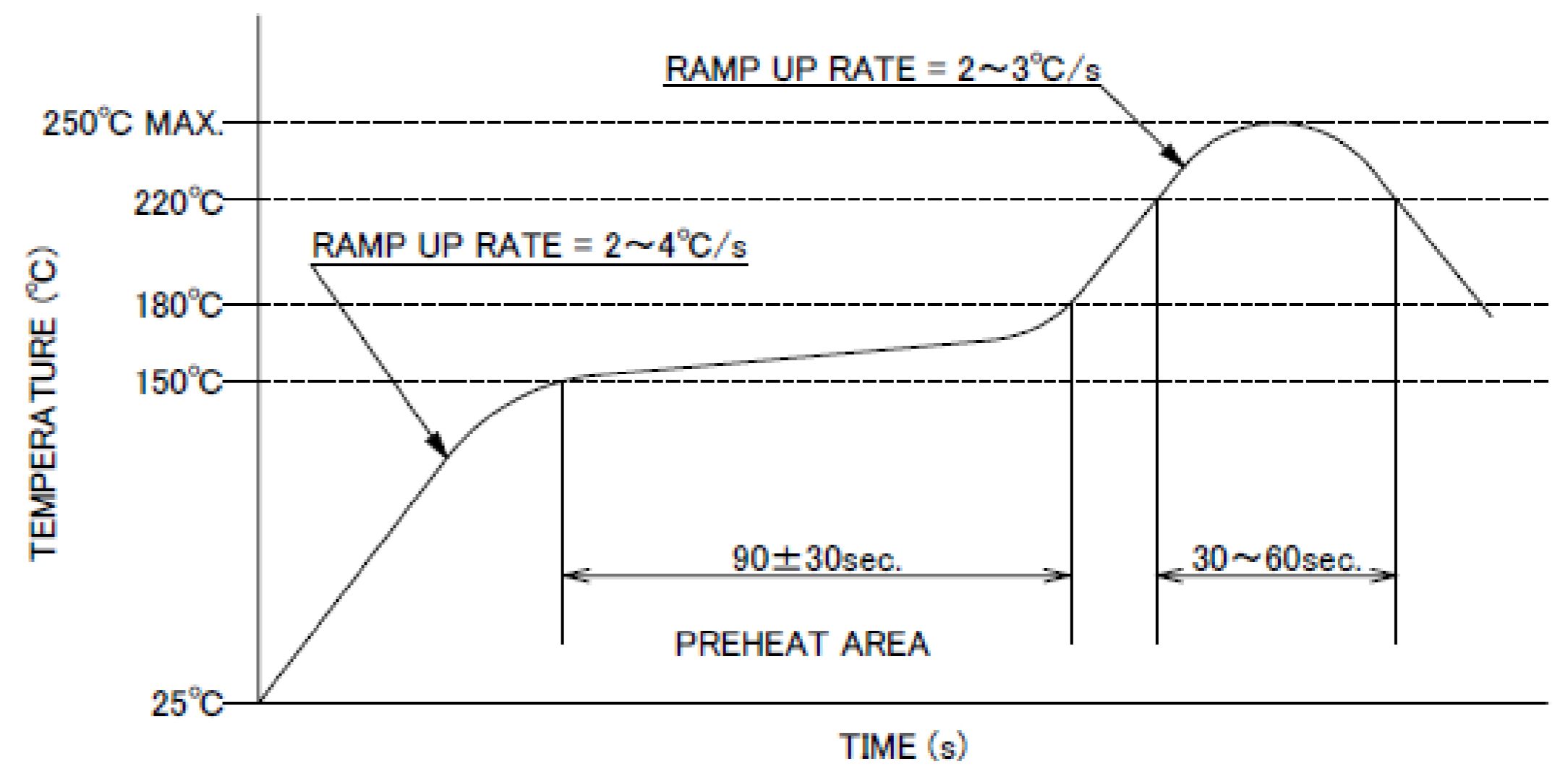
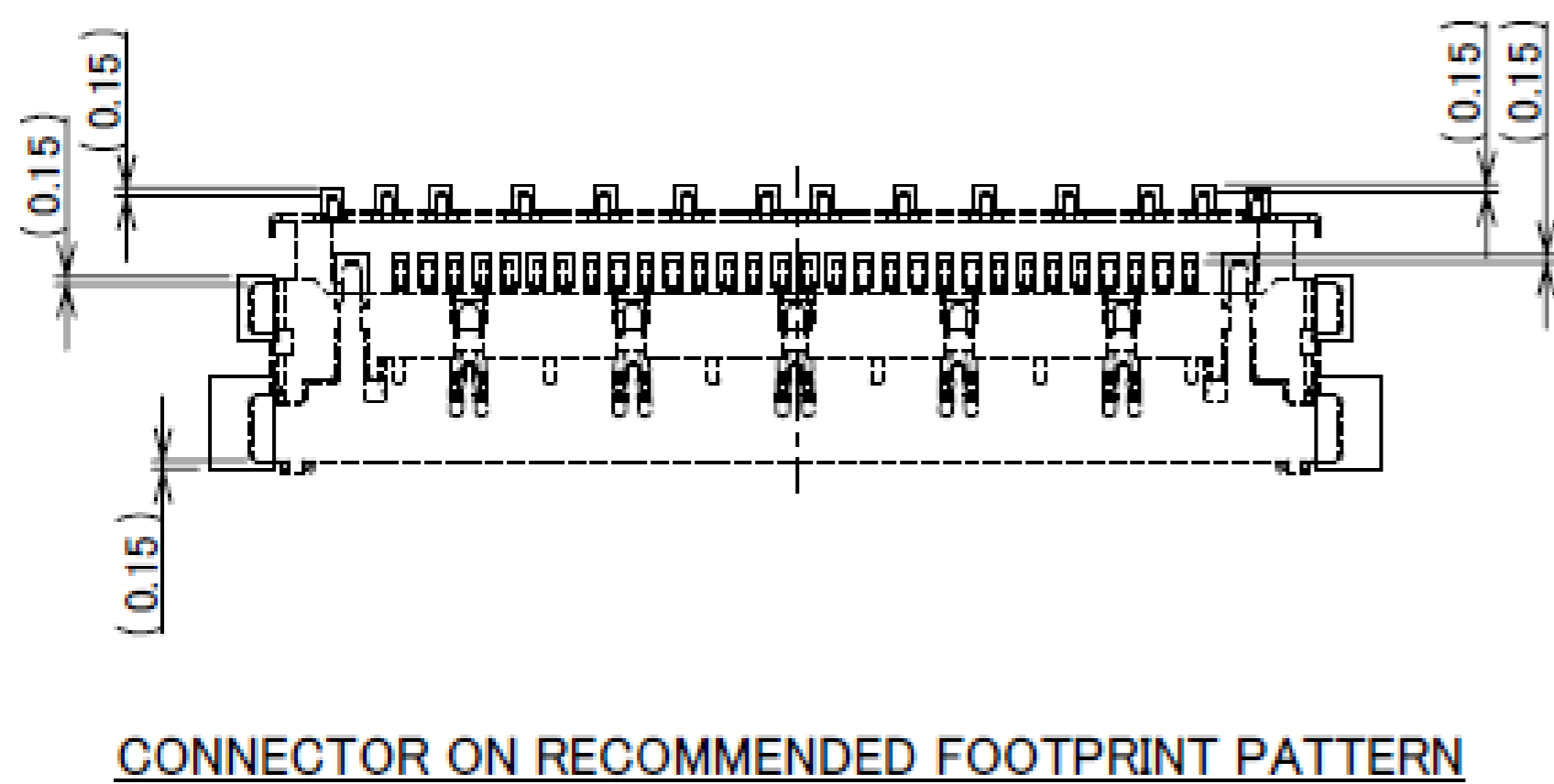

Rev.10

ITEMS	SPECIFICATION
RATING VOLTAGE	100V AC (PER CONTACT PIN)
RATING AMPERAGE (FOR SIGNAL CONTACT)	0.3A AC/DC (PER CONTACT PIN)
OPERATING TEMPERATURE	233~358K(-40°C~+85°C)
OPERATING HUMIDITY	85% MAX.(NON-CONDENSING)
CONTACT RESISTANCE (FOR SIGNAL CONTACT)	INITIAL : 60mohm MAX. / AFTER TEST : \triangle 40mohm MAX.
GROUND SHELL RESISTANCE	INITIAL : 60mohm MAX. / AFTER TEST : \triangle 40mohm MAX.
INSULATION RESISTANCE	INITIAL : 1000Mohm MIN. / AFTER TEST : 500Mohm MIN.
DIELECTRIC WITHSTANDING VOLTAGE	AC250V 1min
DURABILITY	30 CYCLES
MATING FORCE (INITIAL / AFTER TEST)	30P : 13.50N MAX. 40P : 18.00N MAX.
UNMATING FORCE (INITIAL / AFTER TEST)	30P : 1.44N MIN. 40P : 1.92N MIN.
PRODUCT SPECIFICATION	PRS-2430
TEST REPORT	TR-17086
PACKING STANDARD	PST-17134
INSTRUCTION MANUAL	HIM-17039
ASSEMBLY MANUAL	ASM-17010
APPEARANCE CRITERIA No.	QLS-A***

Rev.8

Custom Connectors Available

 RF Connector

MHF® series



CABLINÉ® series
Micro-coaxial/Twinax/
Discrete Wire Connector

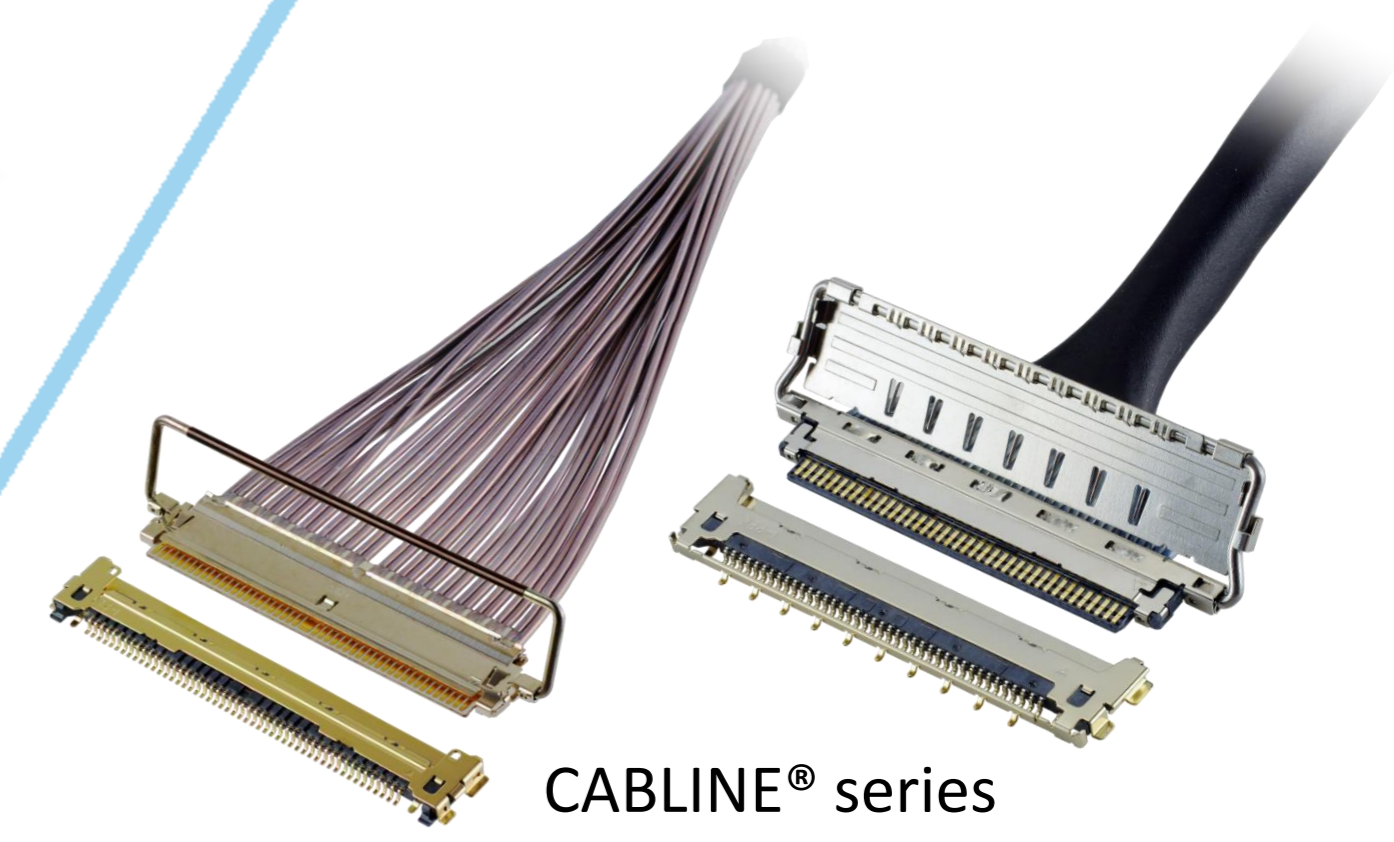

Optical Module

LIGHTPASS® series



NOVASTACK® series



Board-to-Board Connector

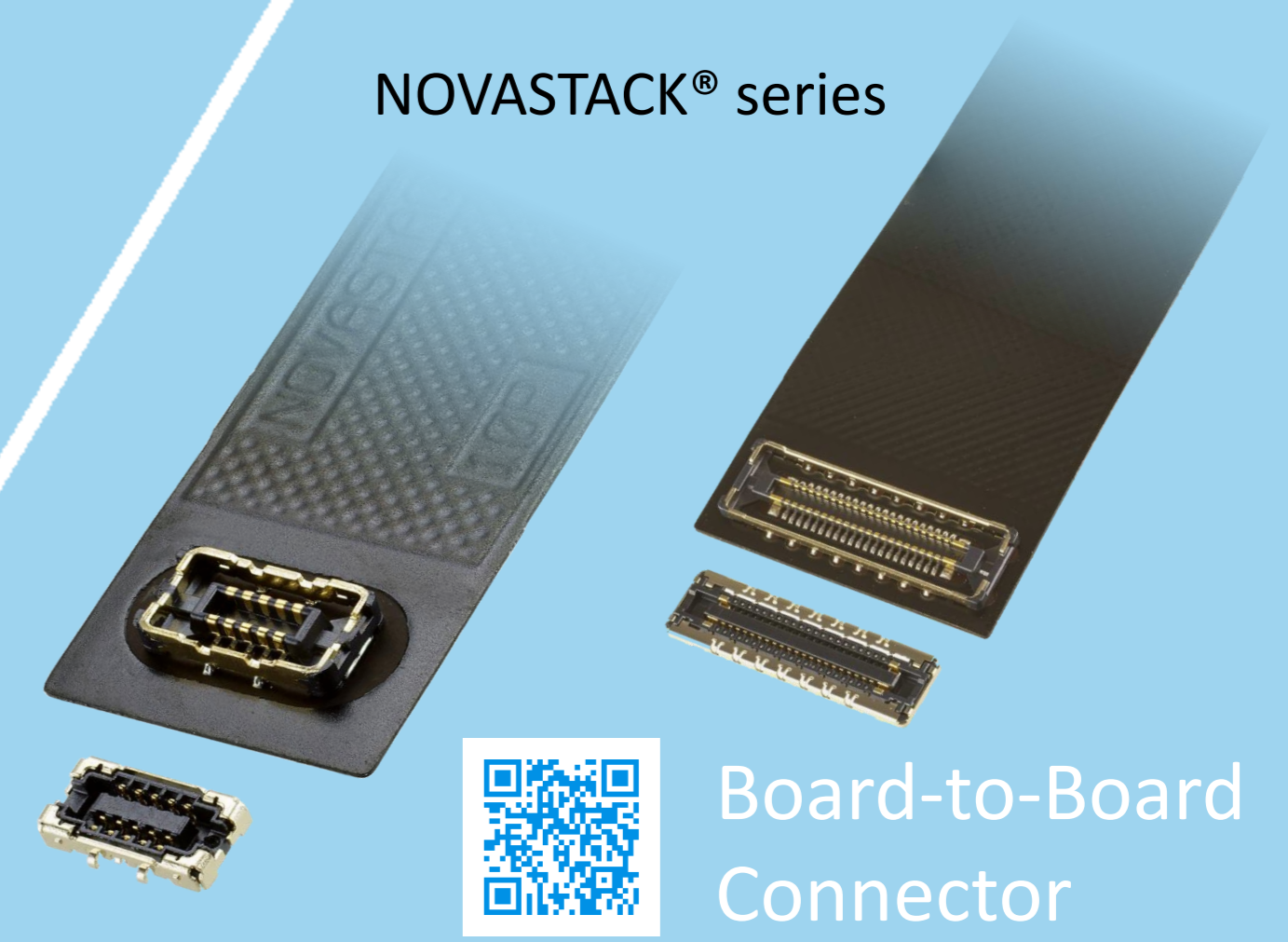

Power Connector/
Terminal

AP series

ISH® series



MINIFLEX® series

EVAFLEX® series



FPC FFC Connector



Inquiry



MINIDOCK® series



I/O Connector

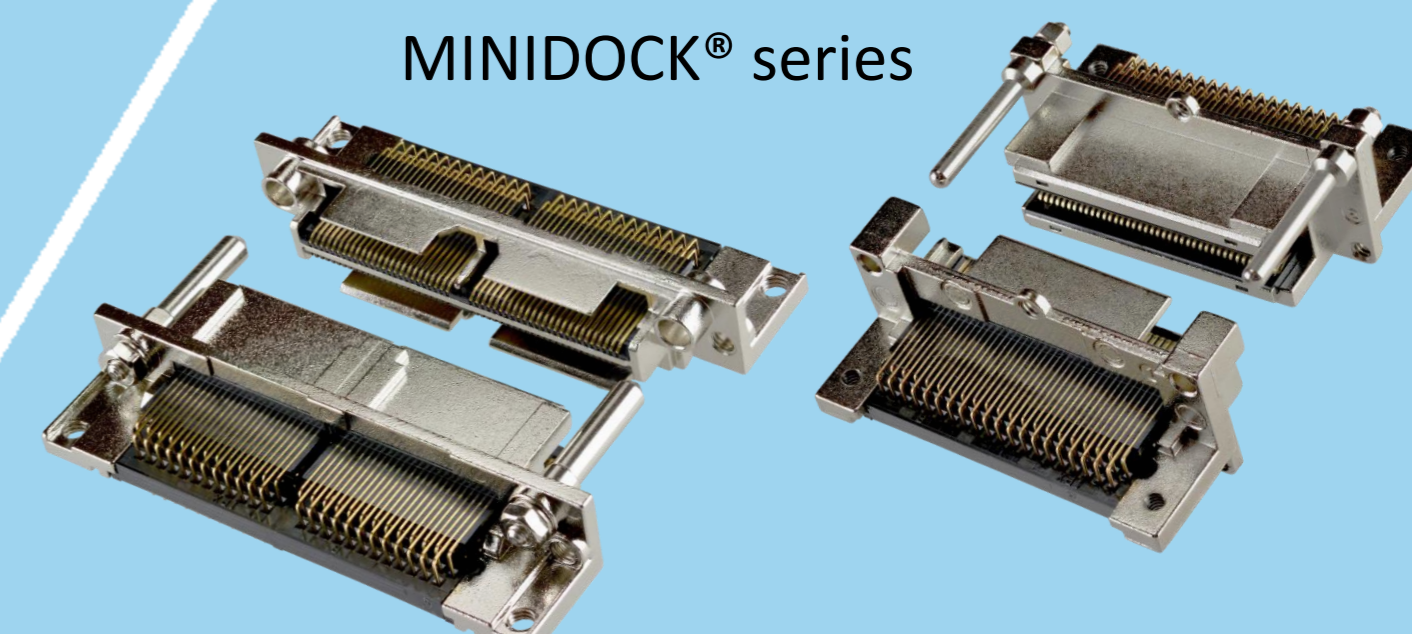

I-PEX, MHF, CABLINE, LIGHTPASS, NOVASTACK, ISH, IARPB, MINIFLEX, EVAFLEX, MINIDOCKS and ZenShield are registered trademarks of I-PEX Inc. Please note that the contents in the catalog might be changed without prior notification. I-PEX Inc. assumes no responsibility for any inaccuracies or obligation to update information on these documents. Please be sure to read and understand the latest "Precautions for Use" and "Instruction Manual" before you use our products. We shall not be responsible for any defects, damages or troubles in case you use our products without following the precautions for use. Please feel free to contact our sales representatives when you use our products for any applications that require very high reliability and safety, or that relate to human life (ex. nuclear power control, aerospace, transportation, medical equipment, safety equipment etc.).

Contact your sales representative or more detailed information.

www.i-pex.com



I-PEX

© I-PEX Inc. 2024
All rights reserved