

CABLINE®-UX II

适合通孔解决方案的超细设计，窄间距（0.25 mm），90°出线垂直插拔款的极细同轴线连接器

Product Specifications:

Mating type	Right angle vertical	
Board Pitch (mm)	0.5	
Wiping Length (mm)	0.2	
Mated size (mm)	Height	1.0 +/- 0.1
	Width	Formula: 4.1 + (0.25 * ?p)
	Depth	2.4
Pin Counts	Range	Up to 50
	Available	30, 34, 40, 50

Applicable Cable Size:

Maximum O.D. (mm)	0.25
Micro-Coaxial for Signal (AWG)	45 ohm: #44 or smaller 50 ohm: #46 or smaller
Twinax (AWG)	-
Discrete (AWG)	#39 or smaller

Applicable Standards (Reference Only):

USB 3.1 Gen 1 (5 Gbps), V-By-One HS 1.4 (4 Gbps), HDMI 1.3 (3.4 Gbps)

*如您需要了解未列出或不在范围内的Pin数，请咨询我们。

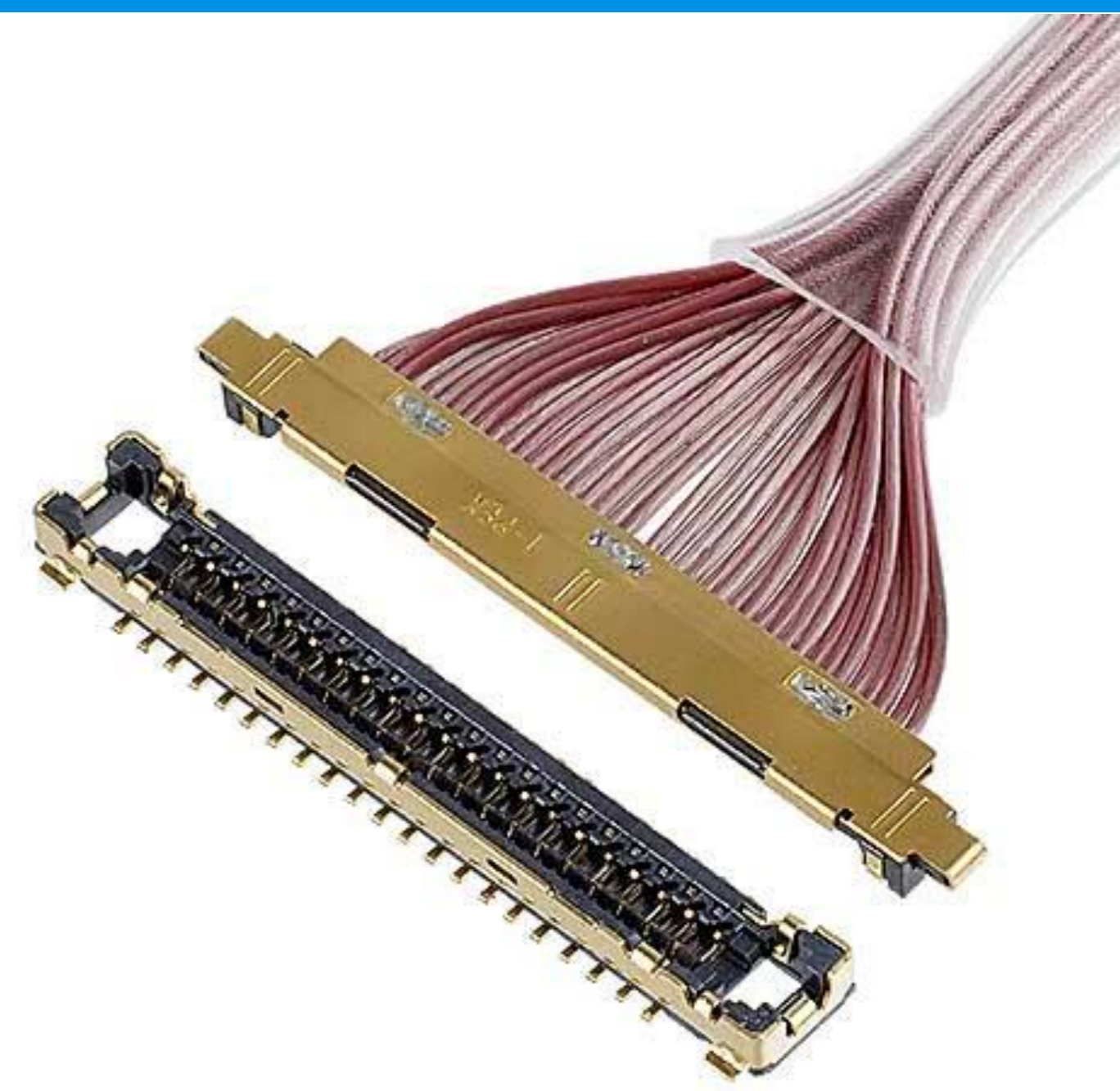

空间有限的小型电子产品的理想选择

CABLINE-UX II 40p 的连接器大小比一分钱硬币还小。

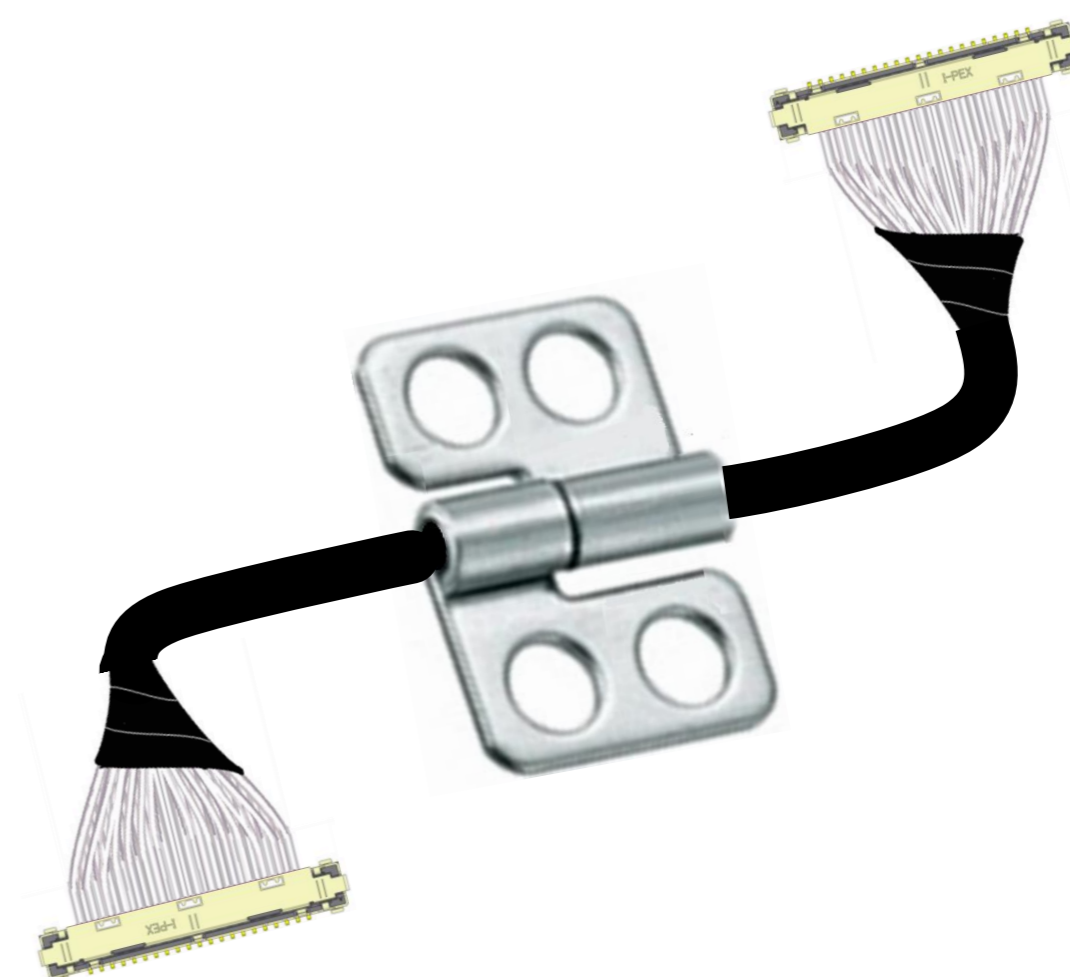
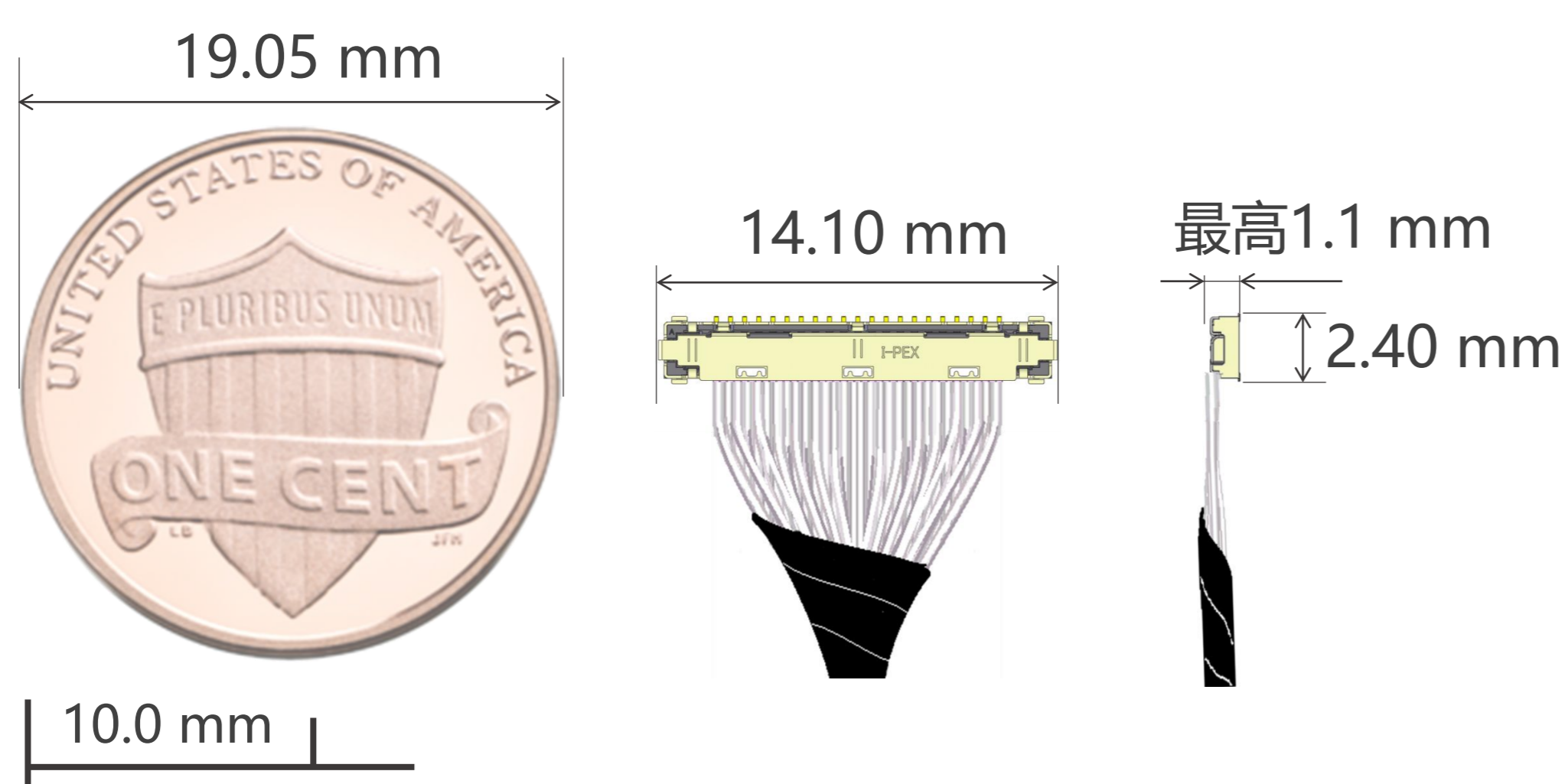

柔软的极细同轴线束
适合用于具有转轴类产品的应用

Plug尺寸也非常小巧，能够方便穿过转轴

模拟参考示例：

当使用外径为0.24 mm的同轴线加工成的 UX II 40pin 线束可以穿过内孔径为 $\Phi 2.66$ mm的转轴或者软管。

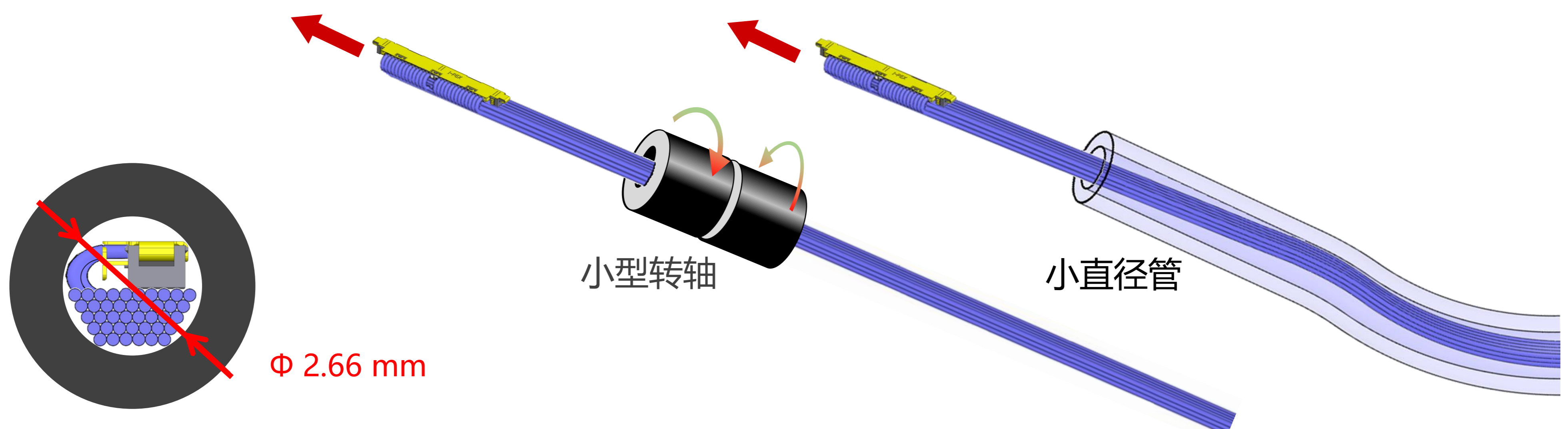

多点接地设计具有良好的抗 EMI 性能

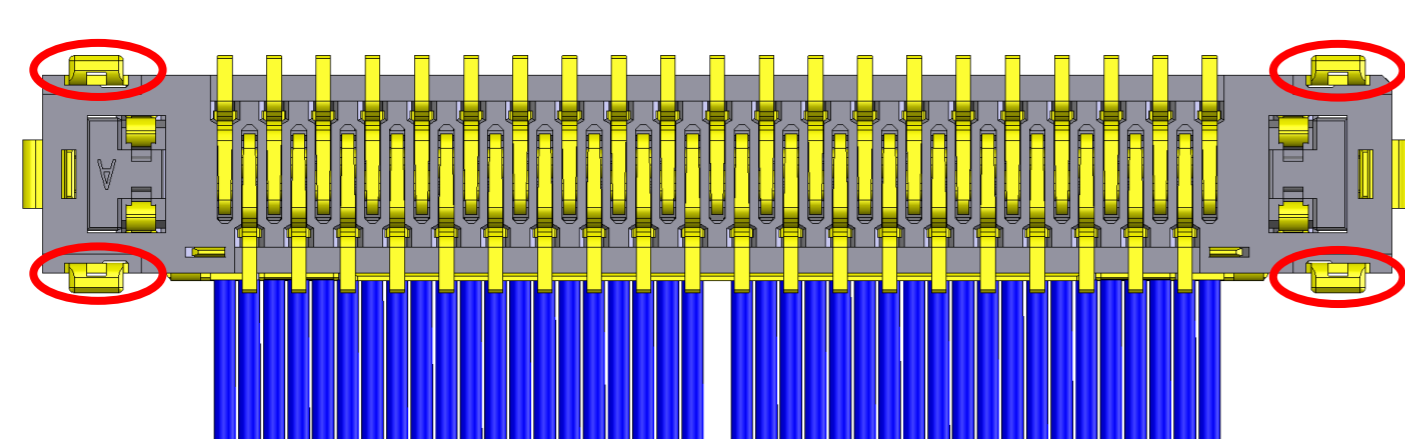

底面图

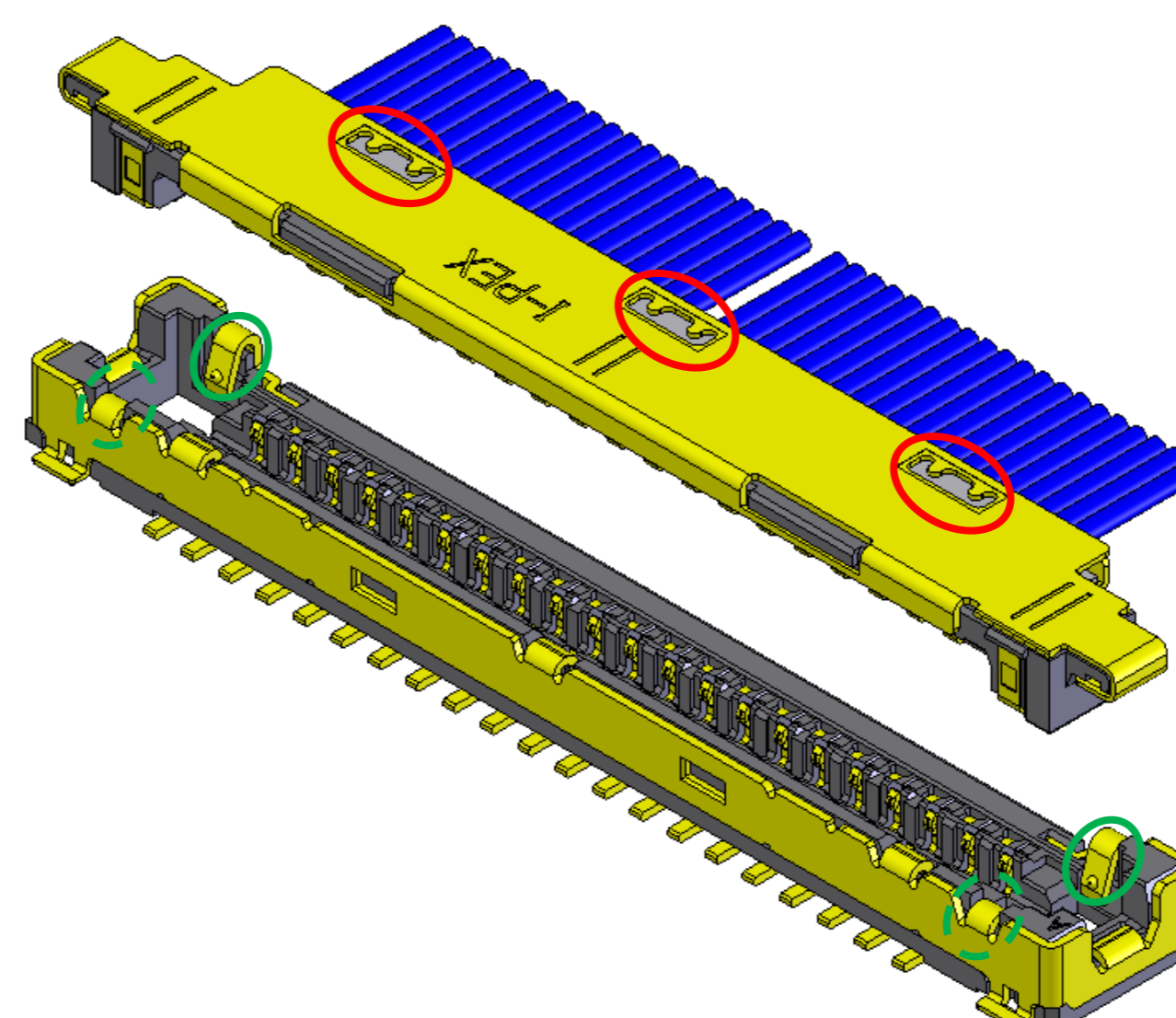

○ 焊接接触点
○ 机械接触点

Component Parts Details

Component Parts

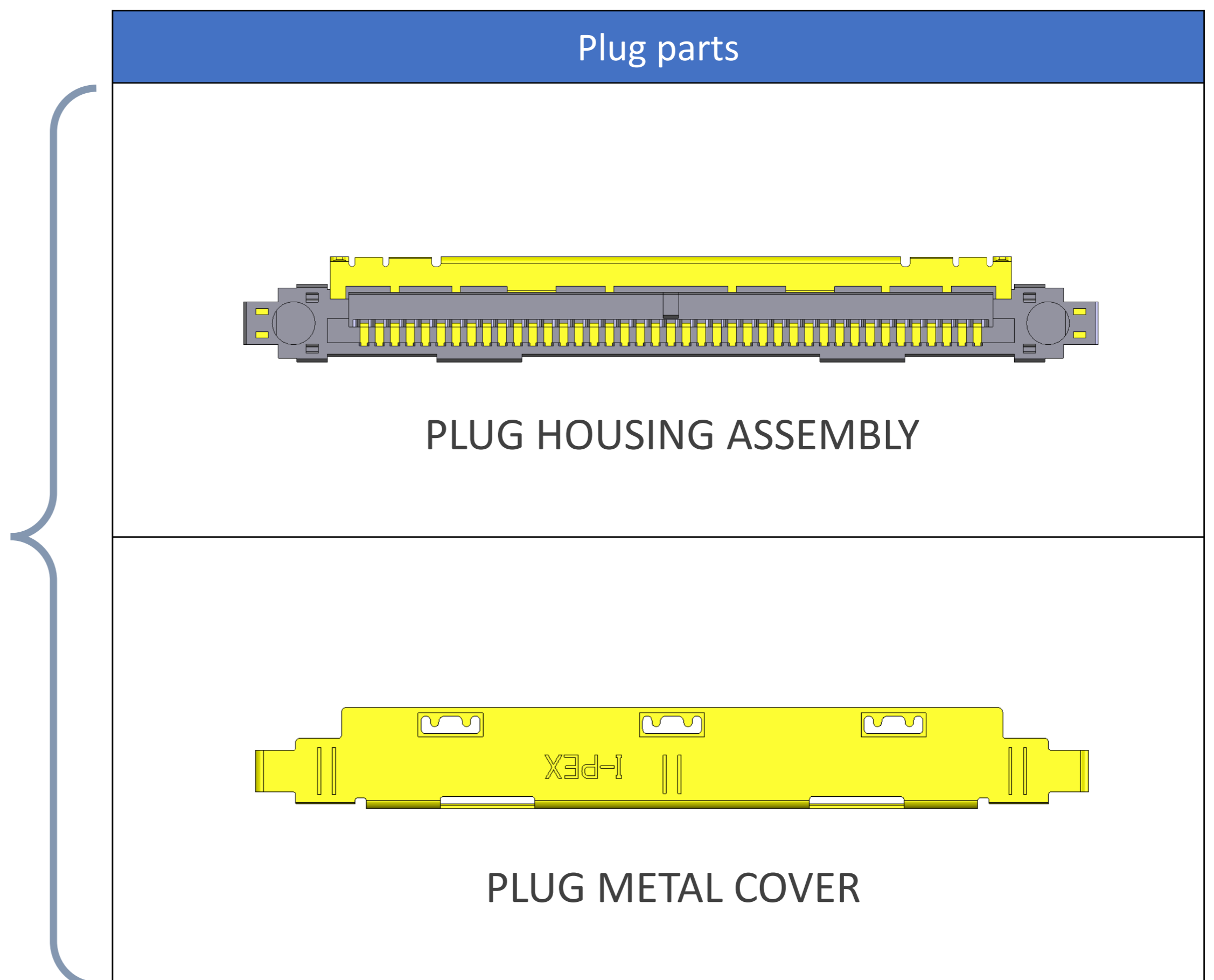
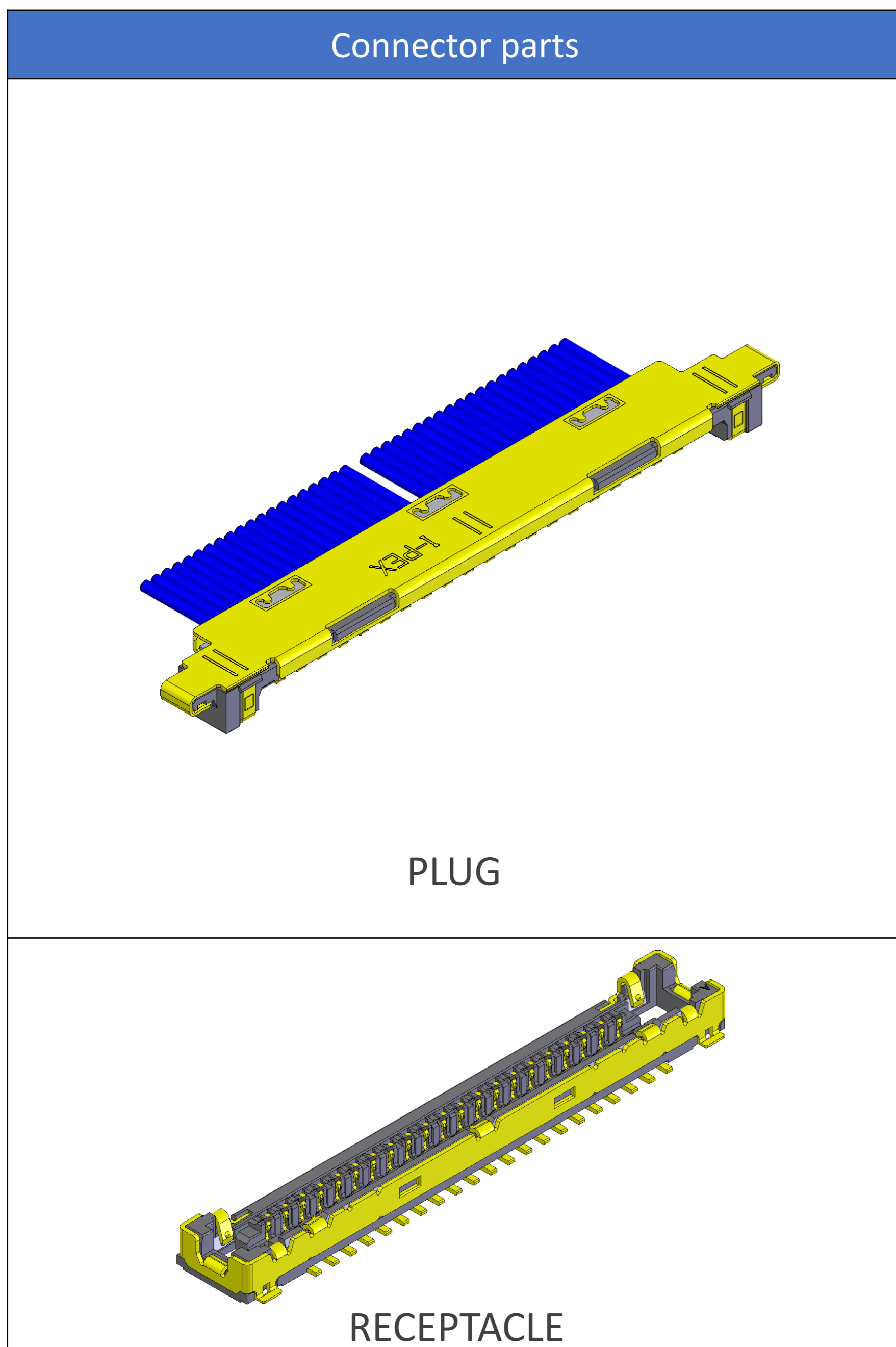

Plug for Cable Assembly

Recommended P/N		20531-0**T-02			
PART No.	A	B	C	D	
20531-030T-#2	10.3	11.6	9.2	5.0	
20531-034T-#2	11.3	12.6	10.2	6.0	
20531-040T-#2	12.8	14.1	11.7	7.5	
20531-050T-#2	15.3	16.6	14.2	10.0	

20531-0**T-#2
SEE TABLE.1
Pos.

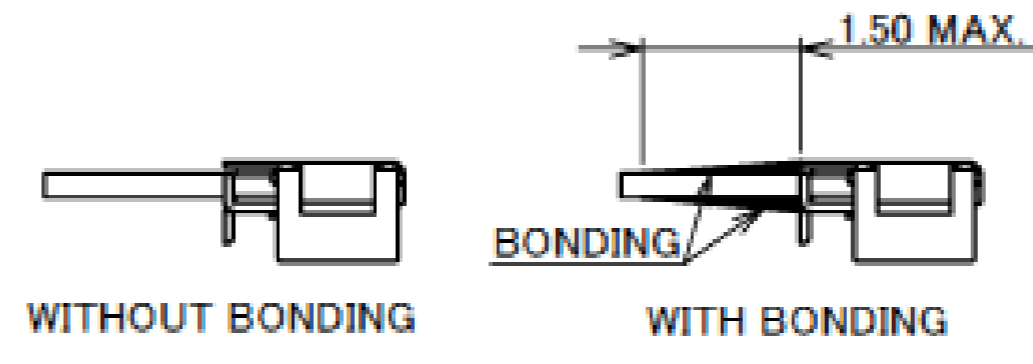

WITHOUT BONDING WITH BONDING
ASSEMBLY STATE
*WE RECOMMEND BONDING THE CABLE AND CONNECTOR TO PROTECT THE CABLE.

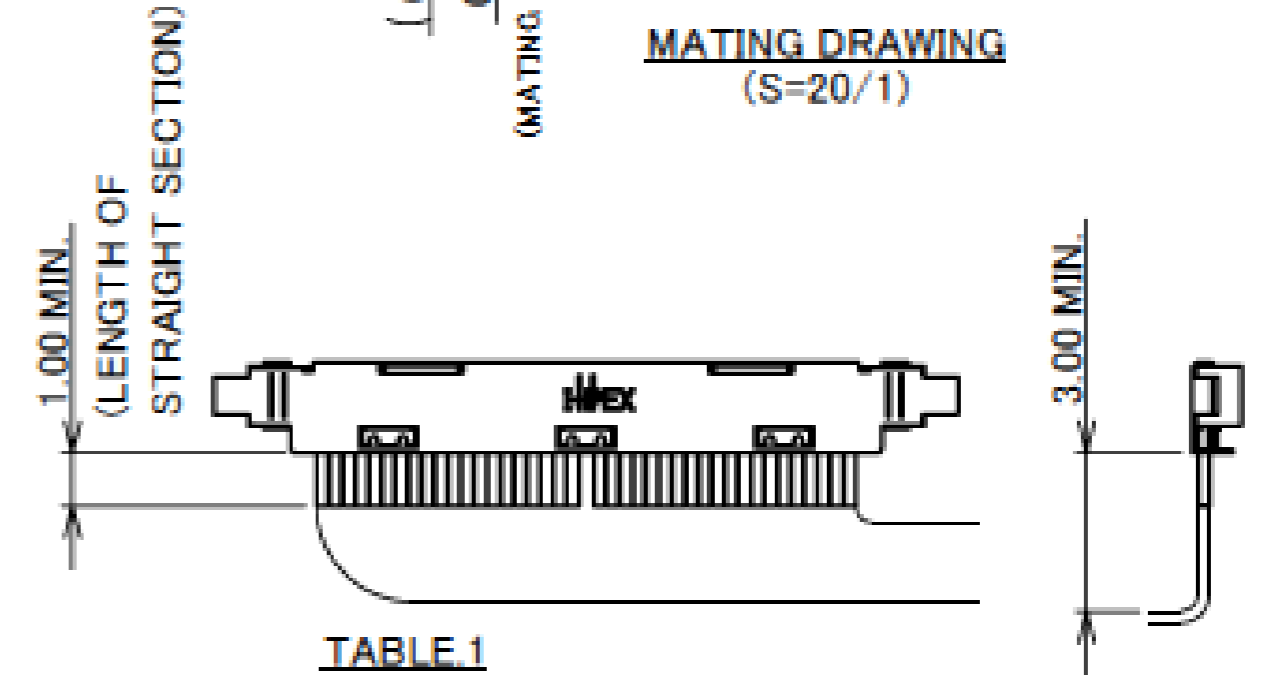
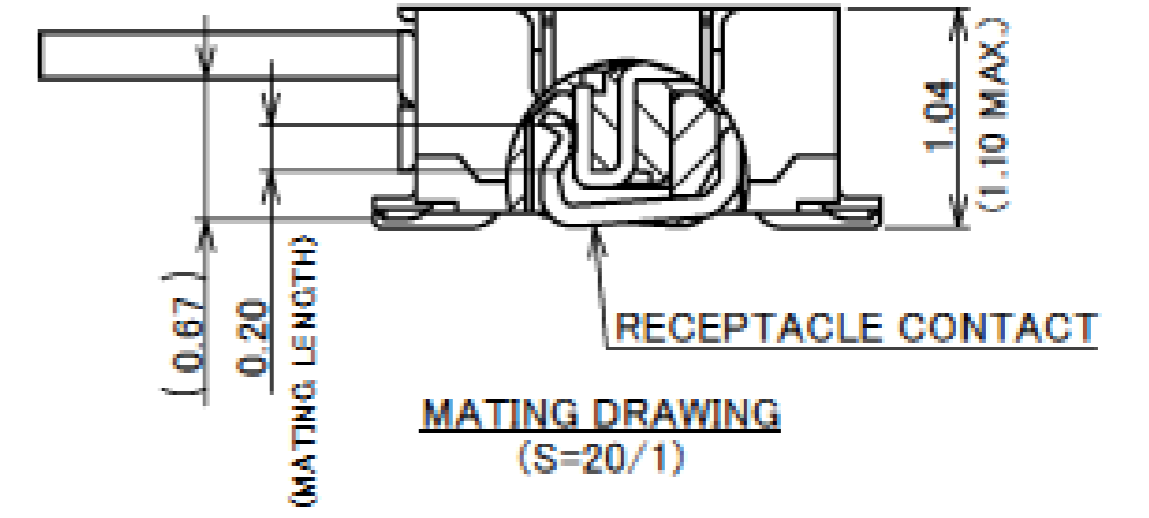
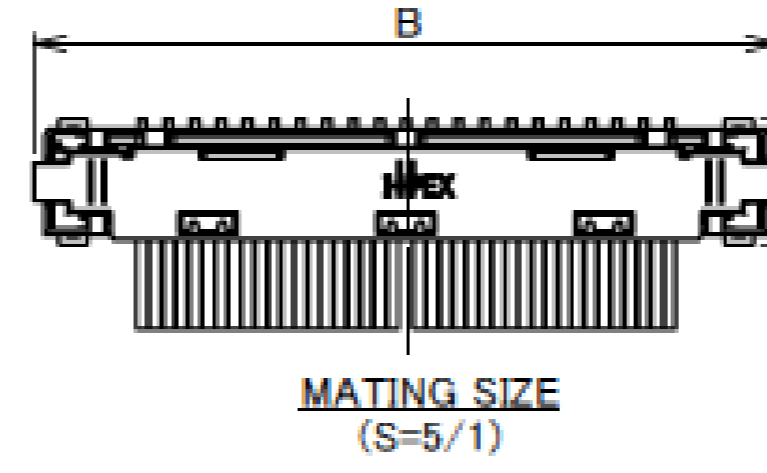
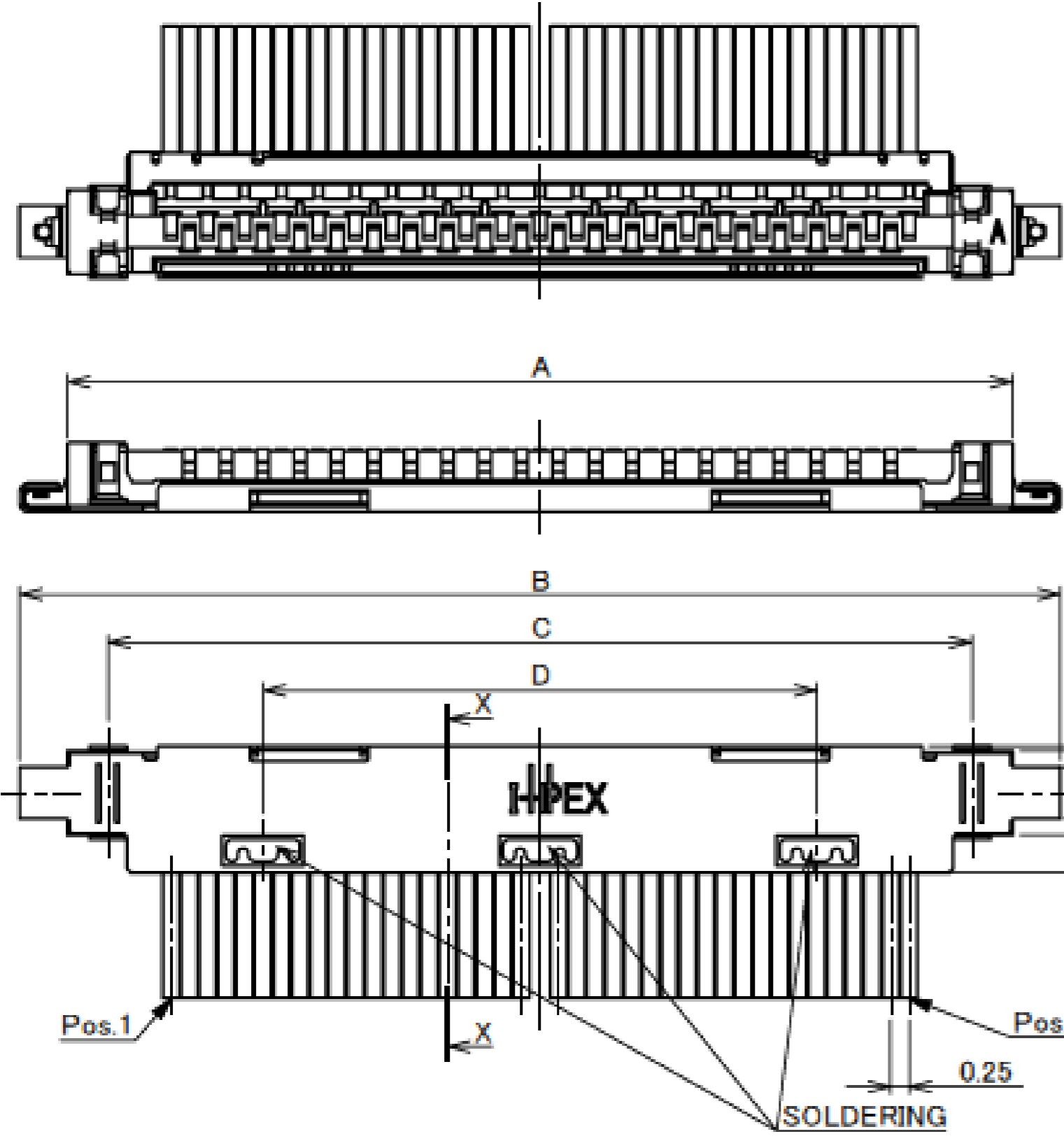
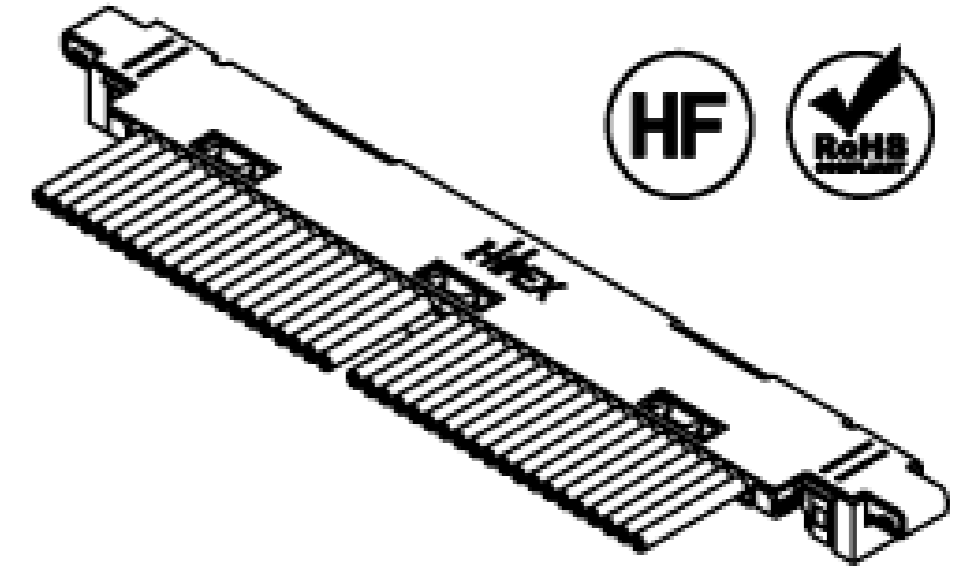
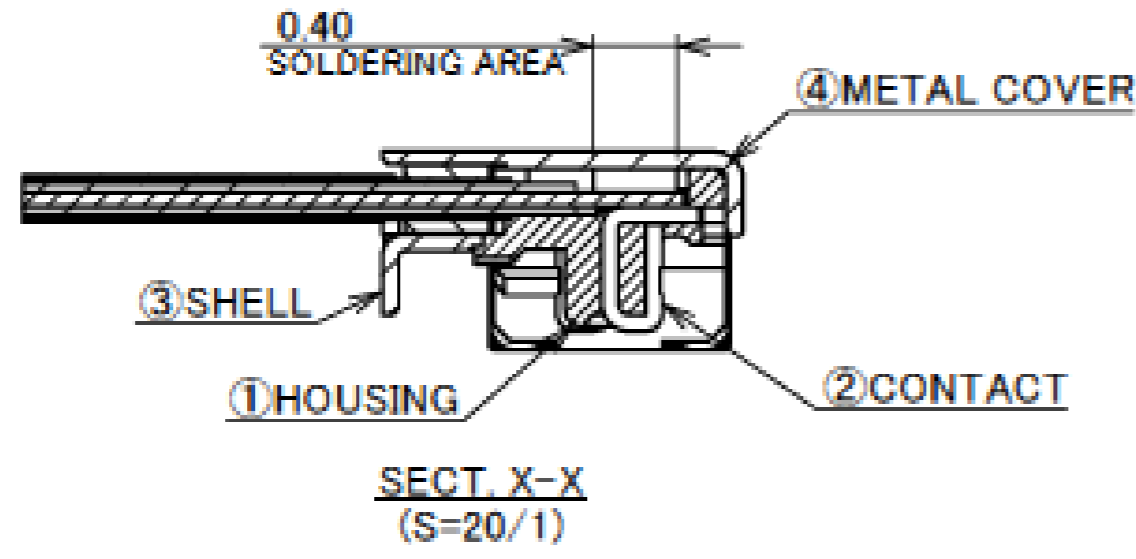

TABLE.1

PART NO.	CONTACT MATERIAL
20531-0**T-02	PHOSPHOR BRONZE
20531-0**T-12	CORSON ALLOY

NO.	DISCRIPTION	MATERIAL	FINISH , REMARKS
4	METAL COVER	SUS	Au 0.05 μm MIN. OVER Ni 1.0 μm MIN.
3	SHELL	PHOSPHOR BRONZE	Au 0.05 μm MIN. OVER Ni 1.0 μm MIN.
2	CONTACT	SEE ABOVE TABLE.1	Au 0.1 μm MIN. OVER Ni 1.0 μm MIN.
1	HOUSING	LCP	UL94V-0 ,BLACK



Rev.13

PART No.	E	F	G
20531-030T-#2	3.5	7.5	8.5
20531-034T-#2	4.0	8.5	9.5
20531-040T-#2	4.75	10.0	11.0
20531-050T-#2	6.0	12.5	13.5

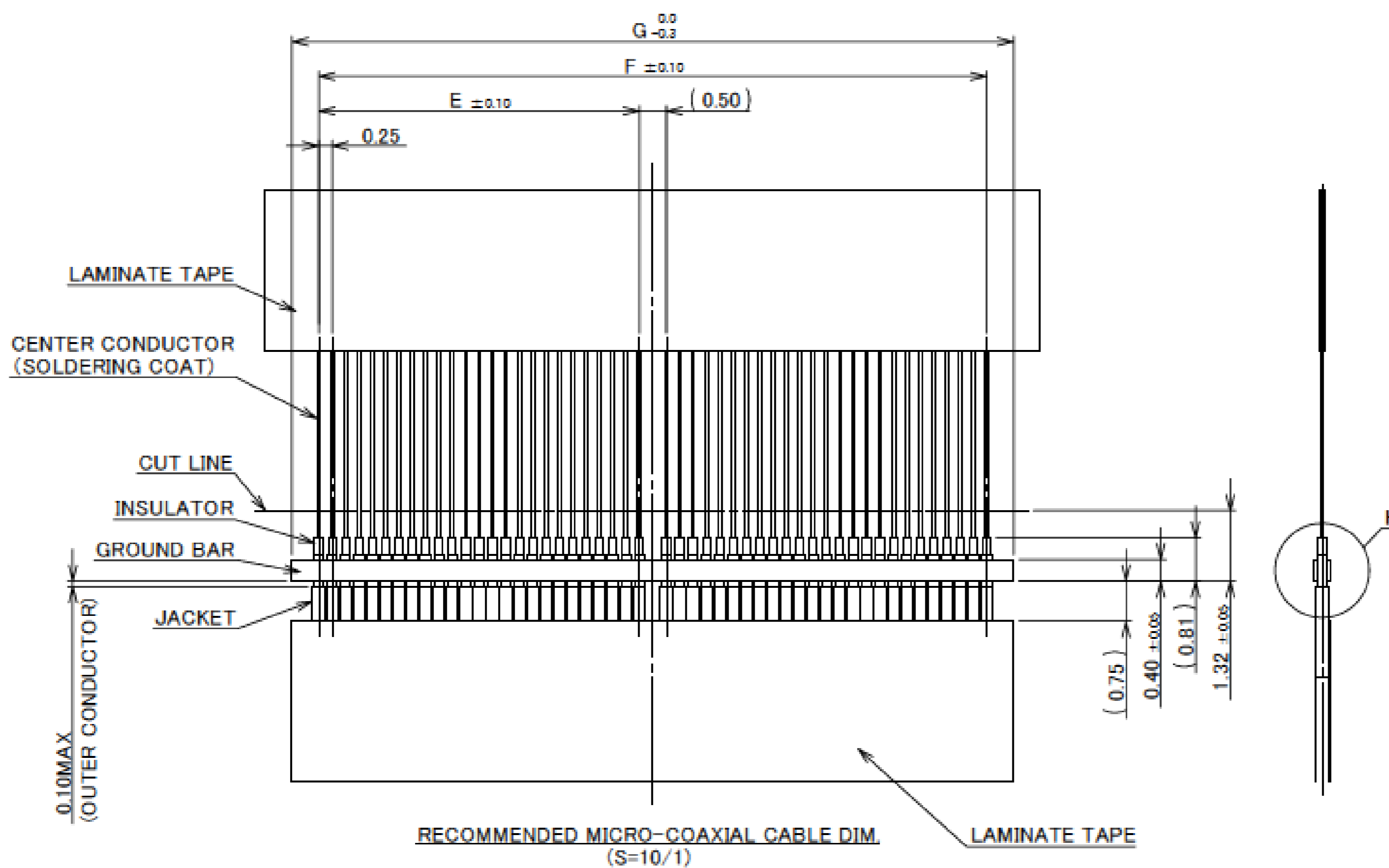

MICRO-COAXIAL CABLE DIMENSION

	a
#44	φ 0.063
#46	φ 0.048

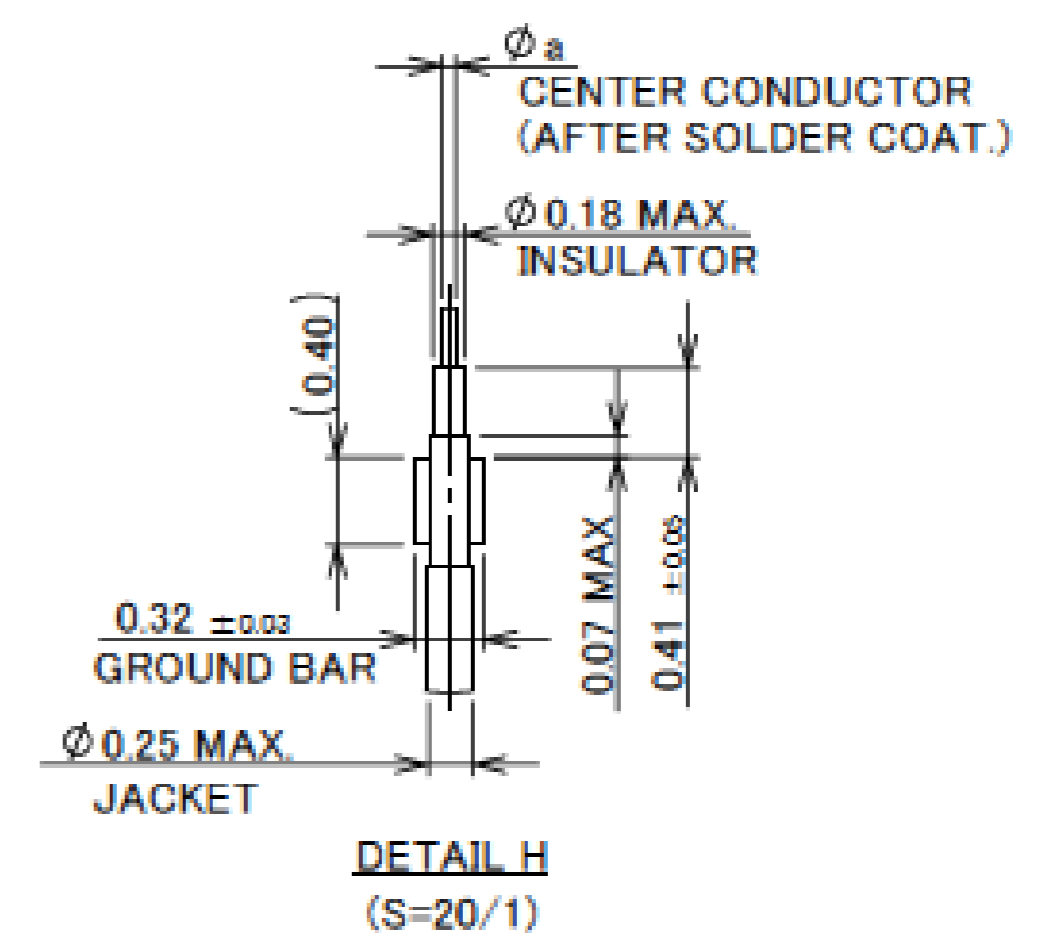

Rev.13

Plug for Cable Assembly

PART No.	E	F
20531-030T-#2	3.5	7.5
20531-034T-#2	4.0	8.5
20531-040T-#2	4.75	10.0
20531-050T-#2	6.0	12.5

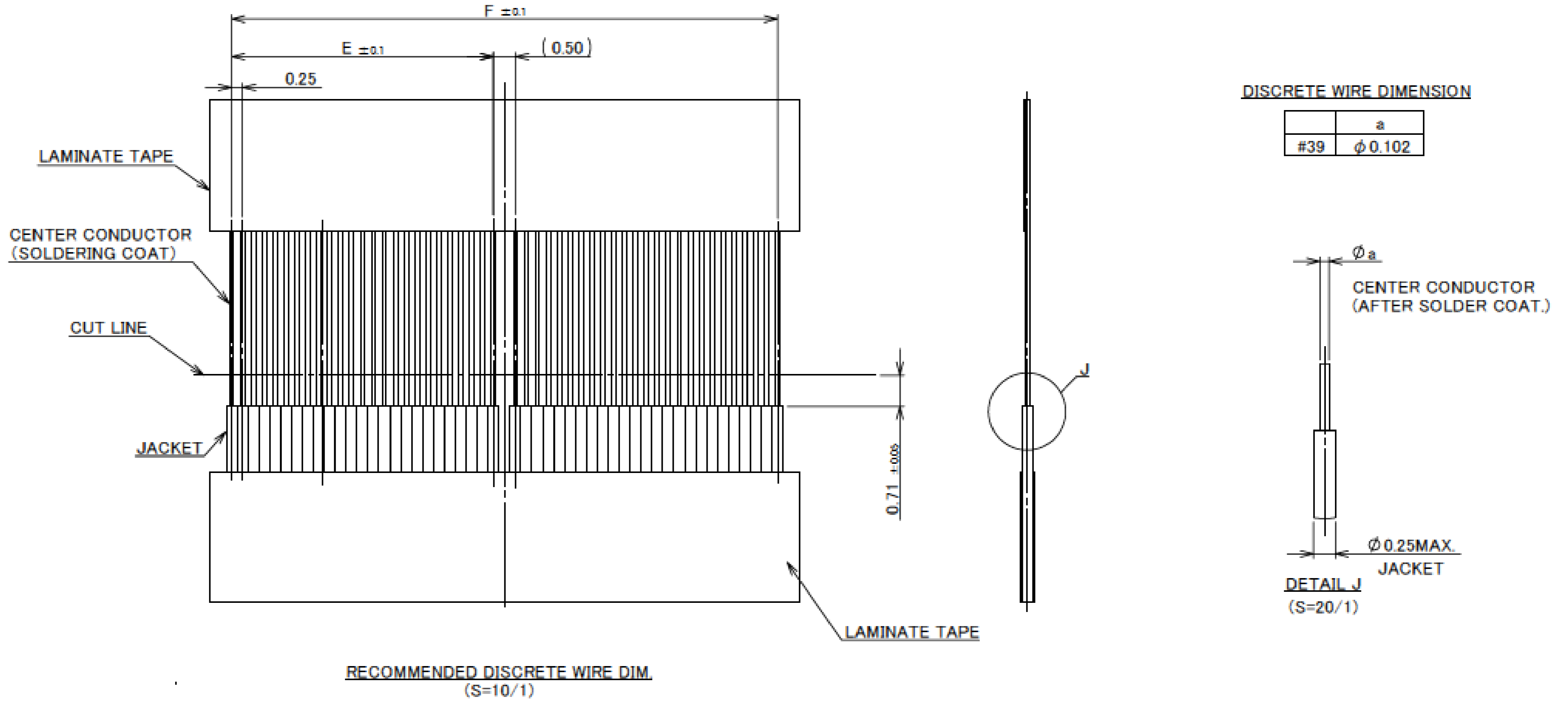

Rev.13

ITEMS	SPECIFICATION
APPLICABLE CABLE	MICRO-COAXIAL CABLE : AWG# 44 ,46 DISCRETE WIRE : AWG#39
RATING VOLTAGE	50V AC (PER CONTACT PIN)
RATING AMPERAGE (FOR CONTACT)	CONTACT MATERIAL : PHOSPHOR BRONZE (PLUG : 20531-0**T-02 ,RECEPTACLE : 20533-0**E) 0.50A AC/DC [AWG#39] (PER CONTACT PIN / UP TO 6 CONTACTS) 0.15A AC/DC [AWG#44] 0.10A AC/DC [AWG#46] CONTACT MATERIAL : CORSON ALLOY (PLUG : 20531-0**T-12 ,RECEPTACLE : 20533-0**E-01) 0.50A AC/DC [AWG#39] (PER CONTACT PIN / UP TO 8 CONTACTS) 0.19A AC/DC [AWG#44] 0.14A AC/DC [AWG#46]
OPERATING TEMPERATURE	233~358K(-40°C~+85°C)
OPERATING HUMIDITY	75% MAX.(NON-CONDENSING)
CONTACT RESISTANCE	INITIAL : 450mohm MAX.(AWG#39) 1080mohm MAX.(AWG#44) 1880mohm MAX.(AWG#46) AFTER TEST : \sphericalangle 40mohm MAX.
GROUND SHELL RESISTANCE	INITIAL : 100mohm MAX. / AFTER TEST : \sphericalangle 140mohm MAX.
INSULATION RESISTANCE	INITIAL : 100Mohm MIN. / AFTER TEST : 100Mohm MIN.
DIELECTRIC WITHSTANDING VOLTAGE	AC100V 1min
DURABILITY	20 CYCLES
MATING FORCE (INITIAL / AFTER TEST)	30P : 26.4N MAX. 34P : 27.6N MAX. 40P : 29.4N MAX. 50P : 32.4N MAX.
UNMATING FORCE (INITIAL / AFTER TEST)	30P : 1.5N MIN. 34P : 1.9N MIN. 40P : 2.5N MIN. 50P : 3.5N MIN.
CABLE RETENTION FORCE	30P : 15.0N MIN. 34P : 17.0N MIN. 40P : 20.0N MIN. 50P : 25.0N MIN.
PRODUCT SPECIFICATION	PRS-1555
TEST REPORT	TR-10051
INSTRUCTION MANUAL	HIM-10001
ASSEMBLY MANUAL	ASM-10001
APPEARANCE CRITERIA No.	QLS-A***

Rev.13

Plug Housing Assembly

Recommended P/N 20532-0**T-02

PART No.	Pos	A	B	C	D	E	F	G	H	J	K	L
20532-030T-#2	30	11.44	10.30	8.70	8.70	7.50	3.75	8.00	8.60	8.00	5.00	7.50
20532-034T-#2	34	12.44	11.30	9.70	9.70	8.50	4.75	9.00	9.60	9.00	6.00	8.50
20532-040T-#2	40	13.94	12.80	11.20	11.20	10.00	6.25	10.50	11.10	10.50	7.50	10.00
20532-050T-#2	50	16.44	15.30	13.70	13.70	12.50	6.25	13.00	13.60	13.00	10.00	12.50

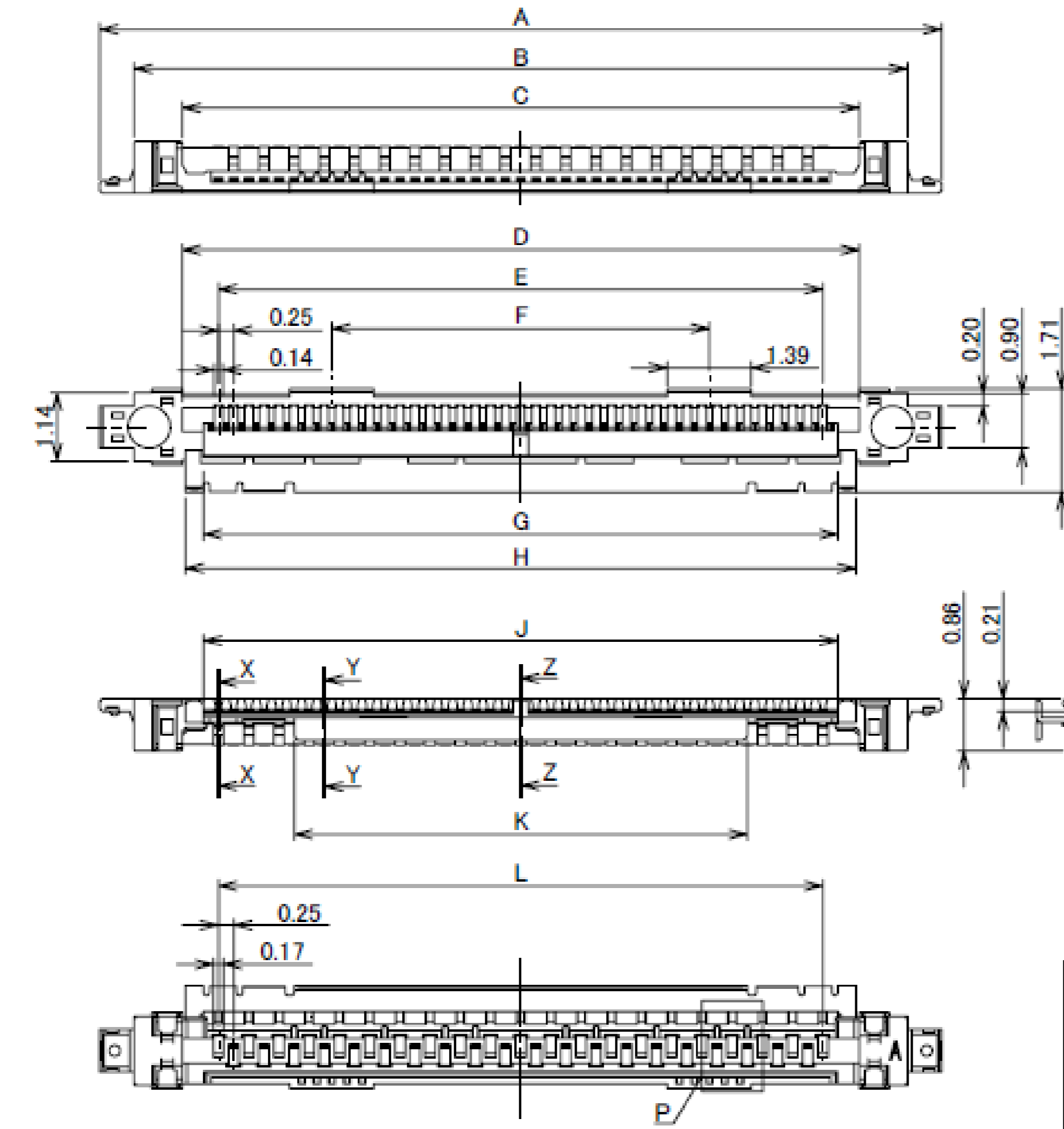

20532-0**T-#2
SEE TABLE.1
Pos.

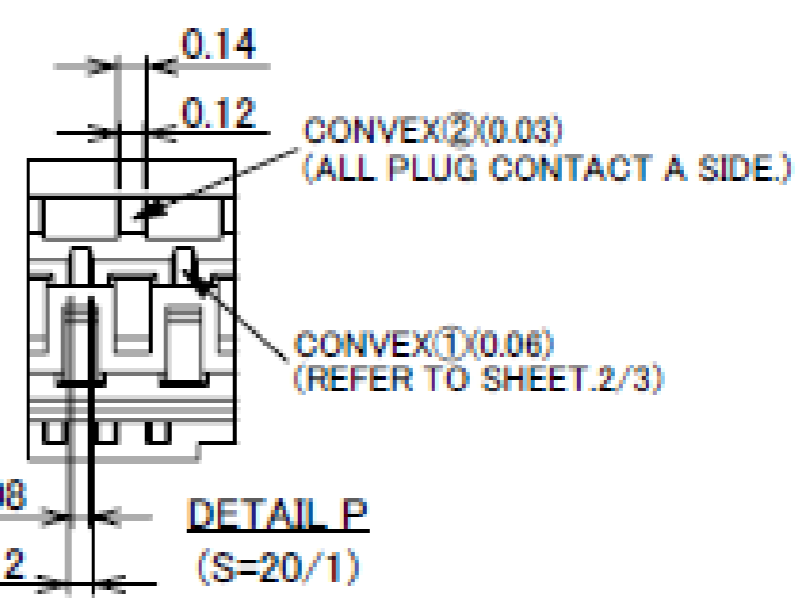
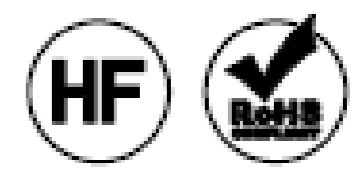
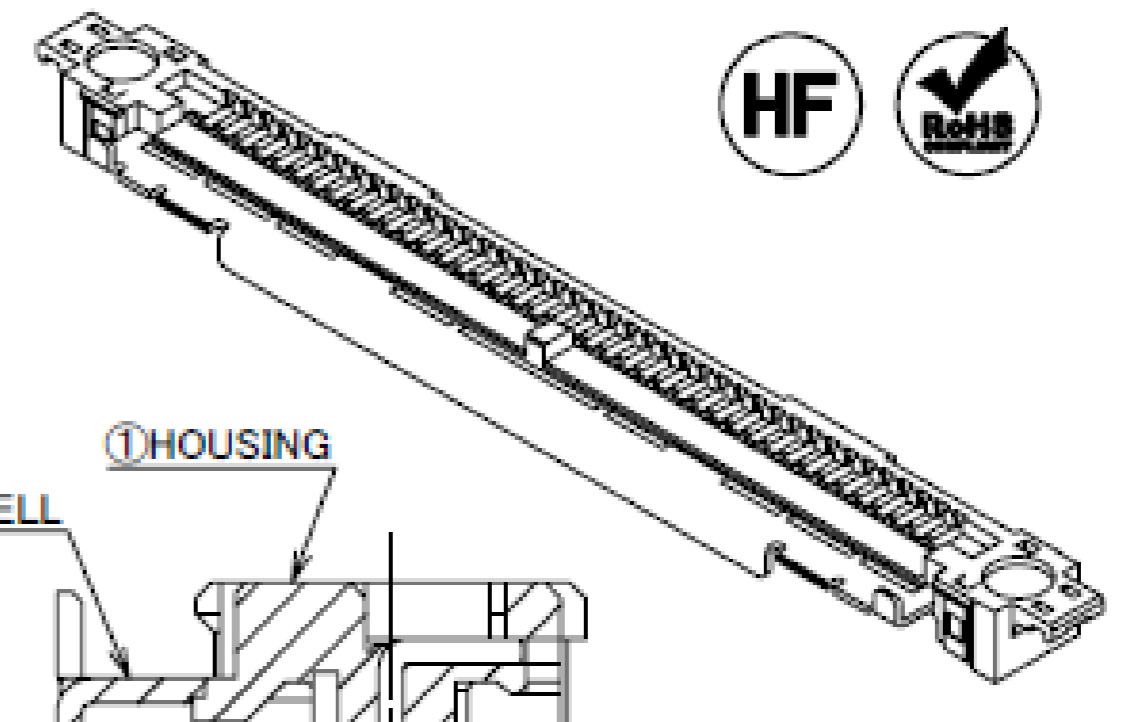
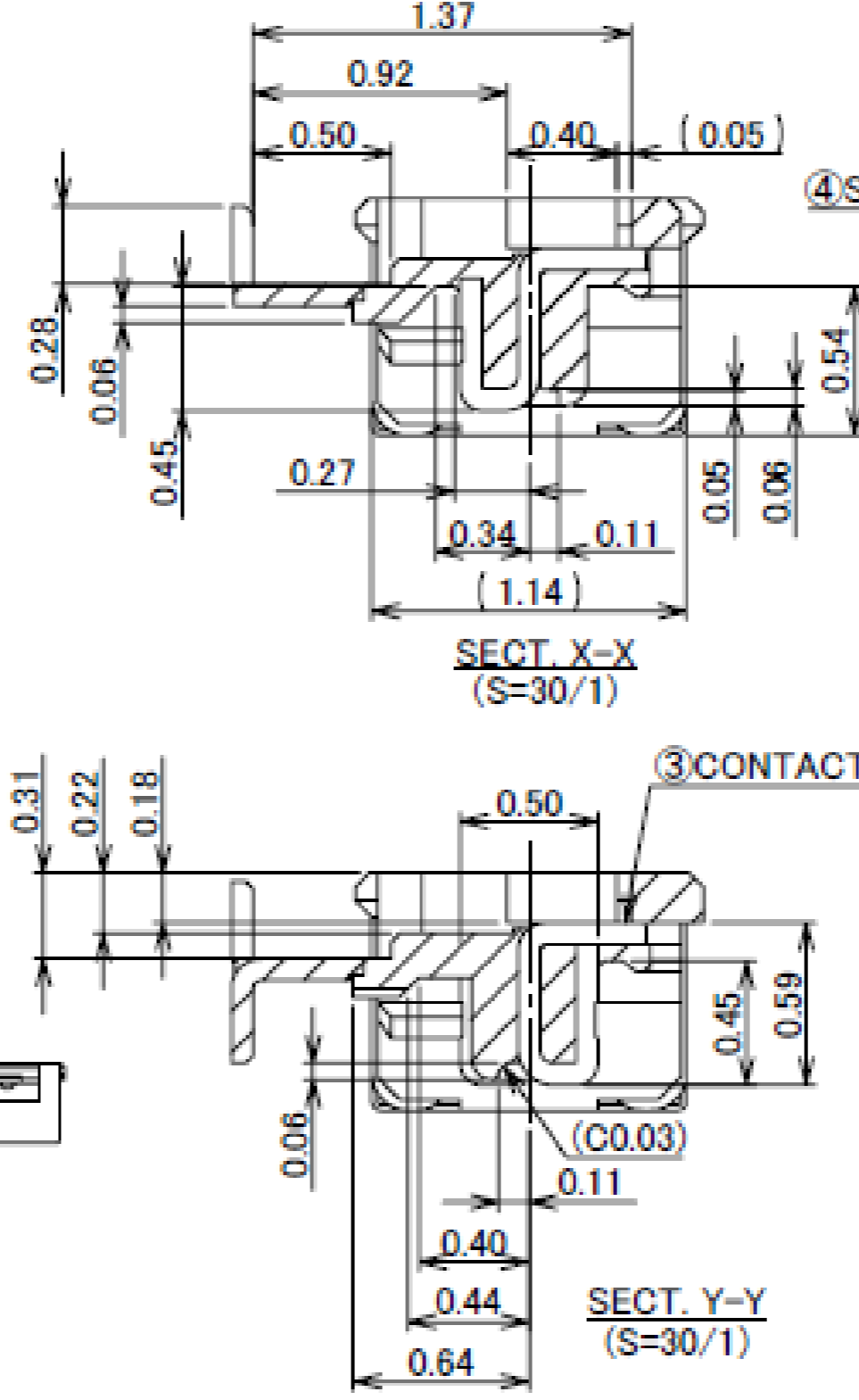
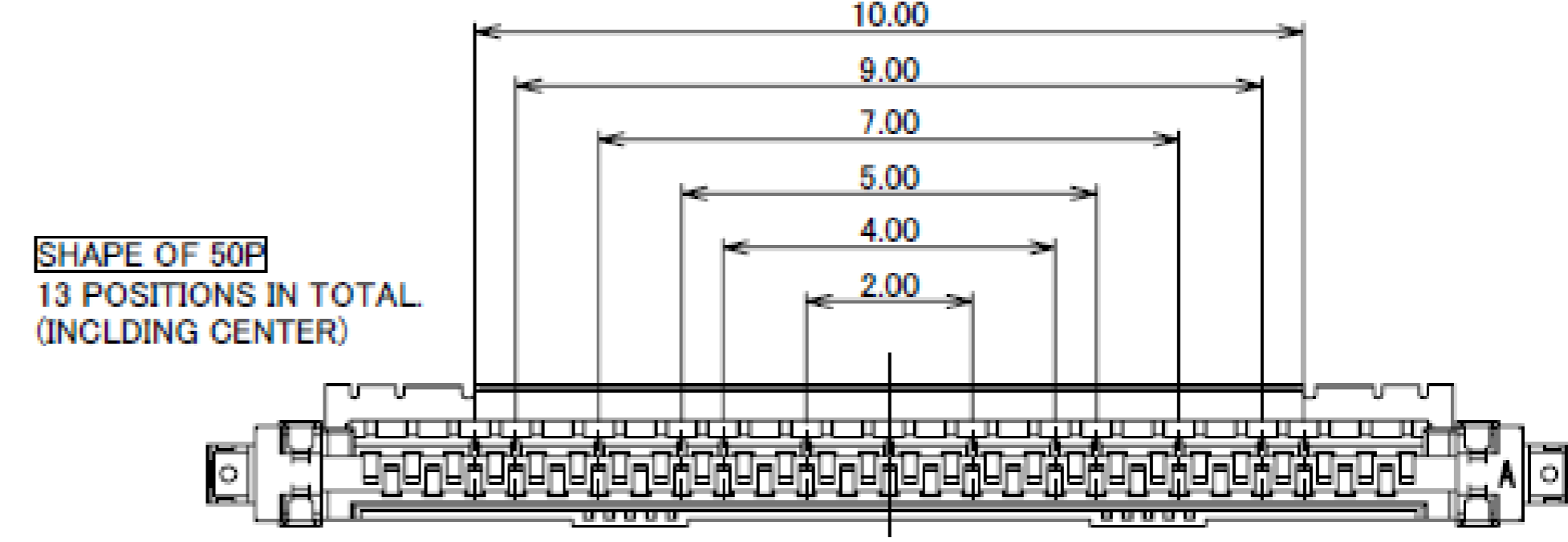
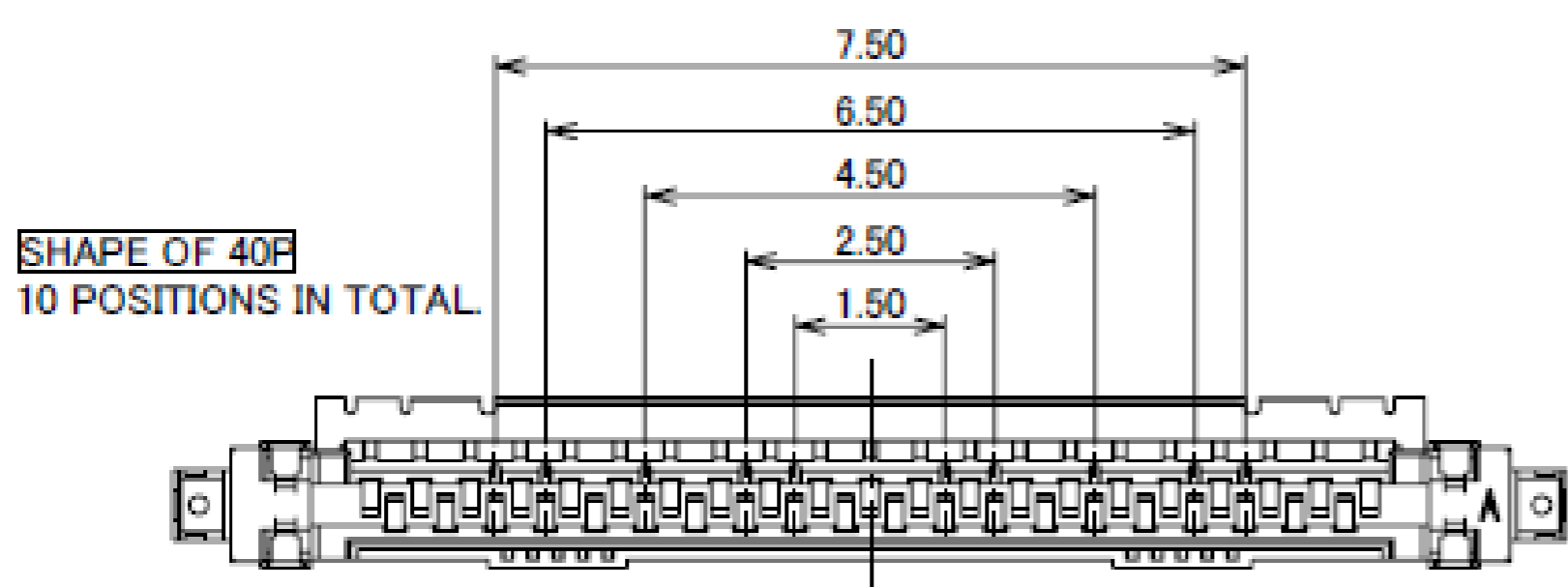
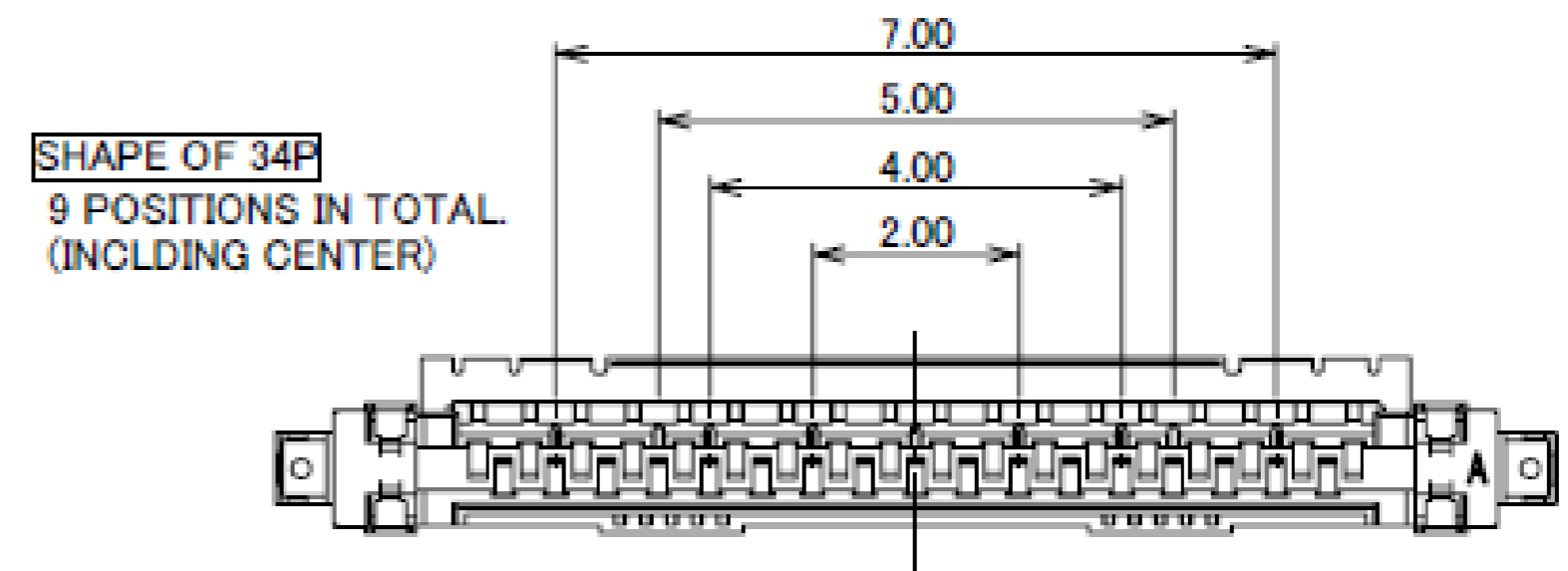
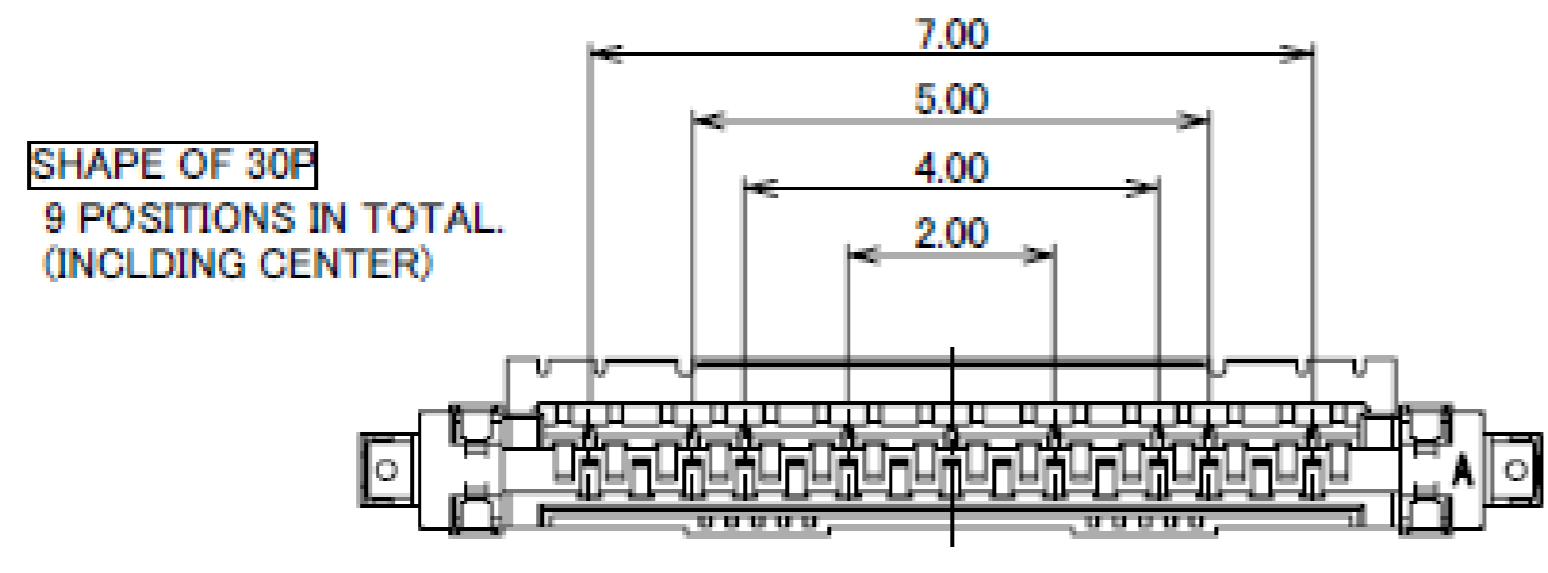

TABLE.1

PART NO.	CONTACT MATERIAL
20532-0**T-02	PHOSPHOR BRONZE
20532-0**T-12	CORSON ALLOY

NO.	DISCRPTION	MATERIAL	FINISH , REMARKS
4	SHELL	PHOSPHOR BRONZE	Au 0.05 μm MIN. OVER Ni 1.00 μm MIN.
3	CONTACT B	SEE ABOVE TABLE.1	Au 0.1 μm MIN. OVER Ni 1.00 μm MIN.
2	CONTACT A	SEE ABOVE TABLE.1	Au 0.1 μm MIN. OVER Ni 1.00 μm MIN.
1	HOUSING	LCP	UL94V-0 ,BLACK



POSITION OF CONVEX(1)

Plug Metal Cover

Recommended P/N	2799-0**1						
PART No.	A	B	C	D	E	F	G
2799-0301	11.60	10.50	7.85	3.75	5.00	8.70	9.20
2799-0341	12.60	11.50	8.85	4.75	6.00	9.70	10.20
2799-0401	14.10	13.00	10.35	6.25	7.50	11.20	11.70
2799-0501	16.60	15.50	12.85	6.25	10.00	13.70	14.20

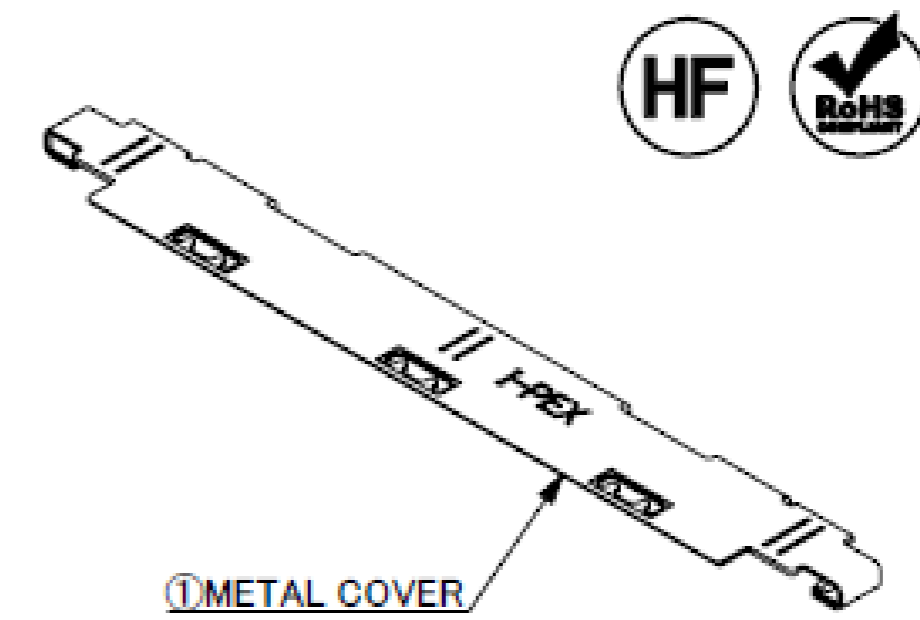
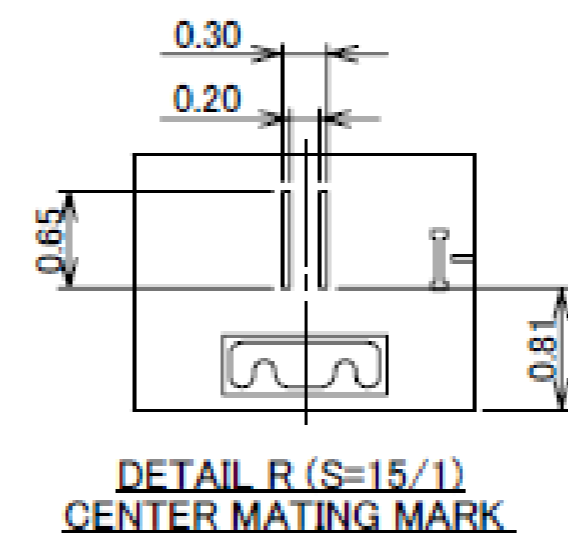
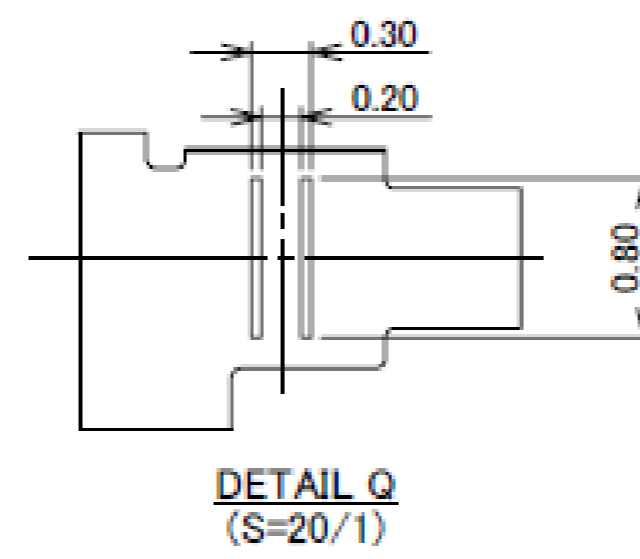
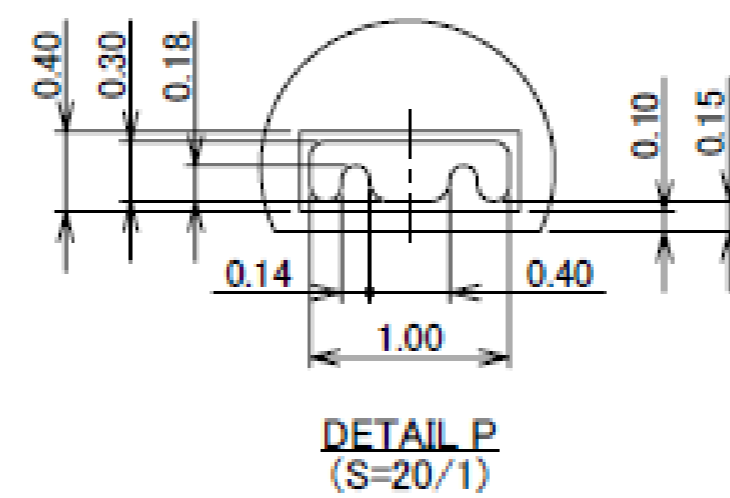
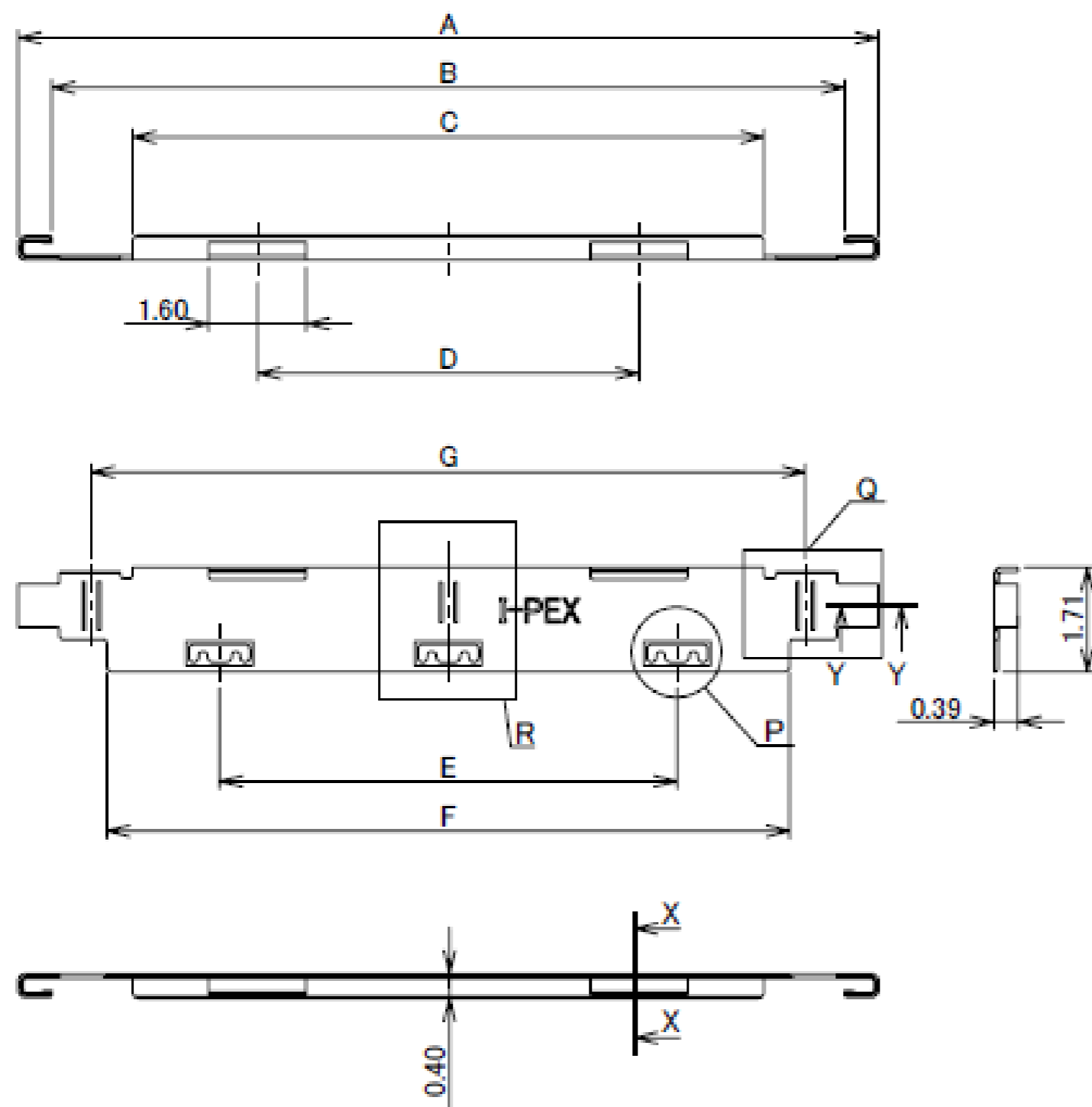

① METAL COVER

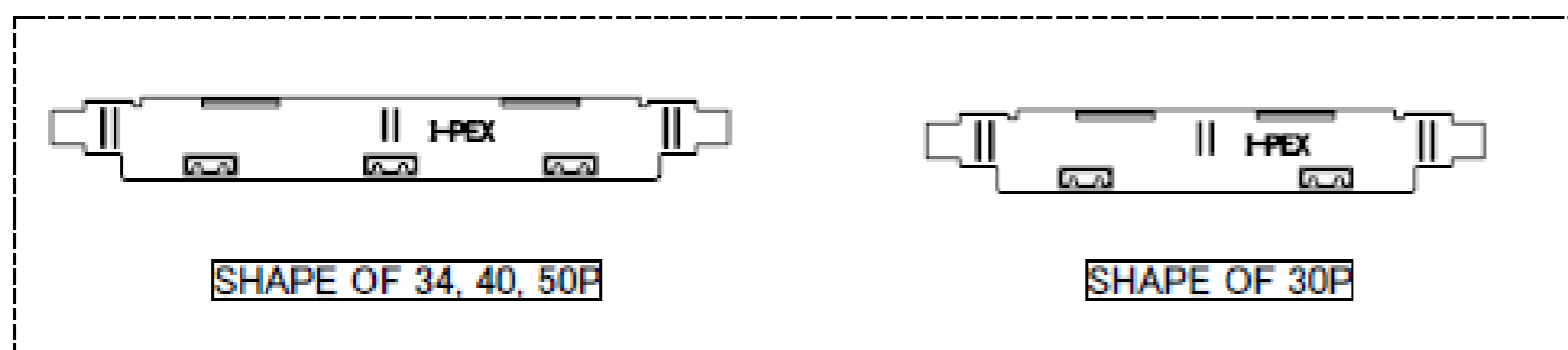
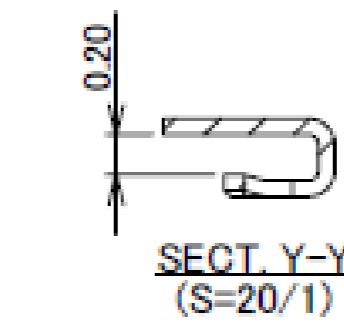
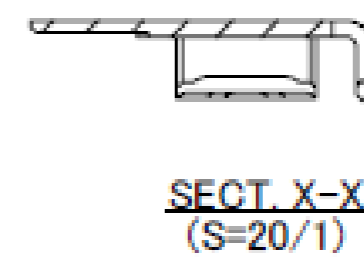

NO.	DISCRIPTION	MATERIAL	FINISH , REMARKS
1	METAL COVER	SUS	Au 0.05 μ m MIN. OVER Ni 1.00 μ m MIN.

Rev.9

Receptacle Assembly

Recommended P/N	20533-0**E					
PART NO.	Pos.	A	B	C	D	E
20533-030E-**	30	11.20	7.50	8.00	10.11	1.60
20533-034E-**	34	12.20	8.50	8.00	11.11	2.10
20533-040E-**	40	13.70	10.00	10.00	12.61	1.85
20533-050E-**	50	16.20	12.50	12.00	15.11	2.10

20533-0**E-**
SEE TABLE.1
Pos.

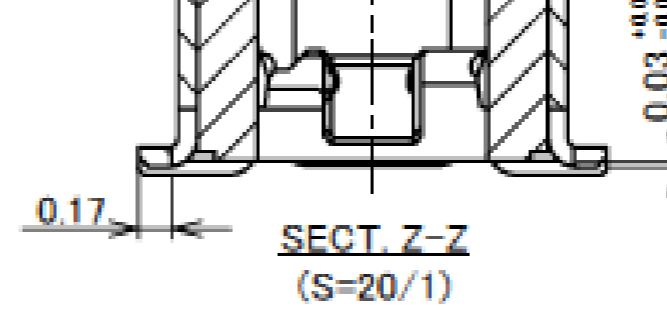
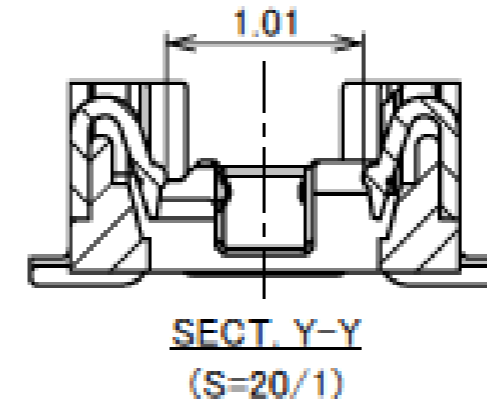
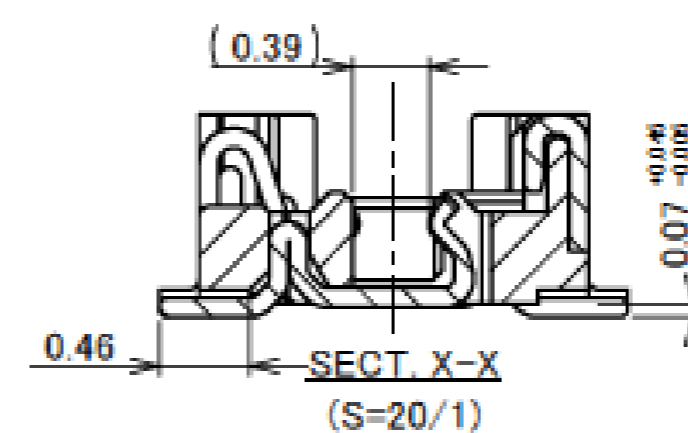
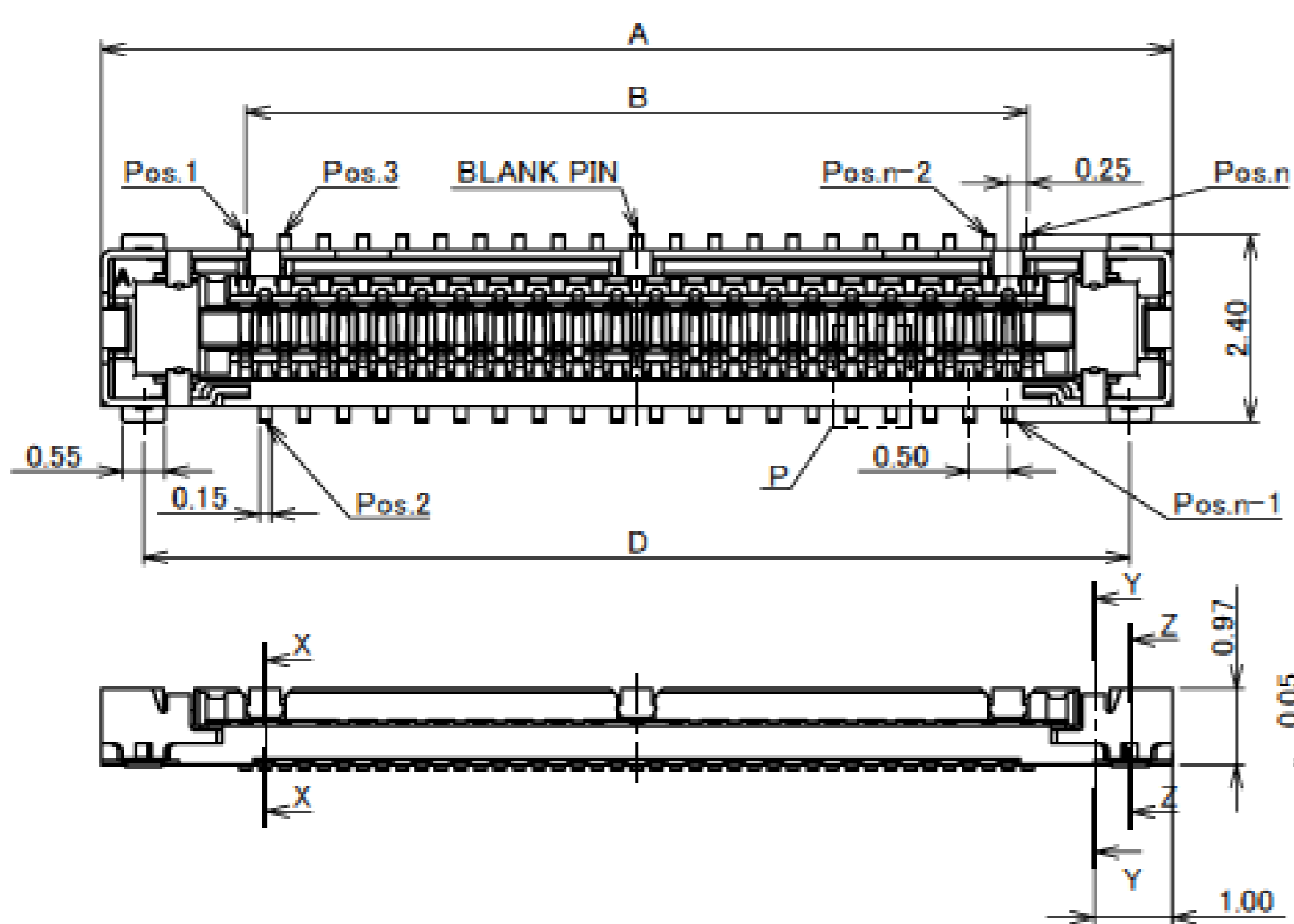

CONCAVE①
REFER TO THE TABLE.2

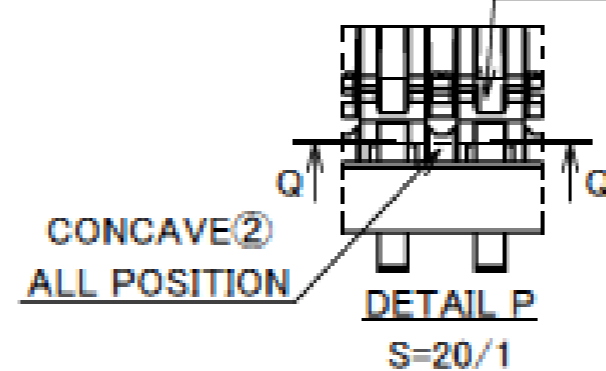

② CONTACT

① HOUSING

③ SHELL

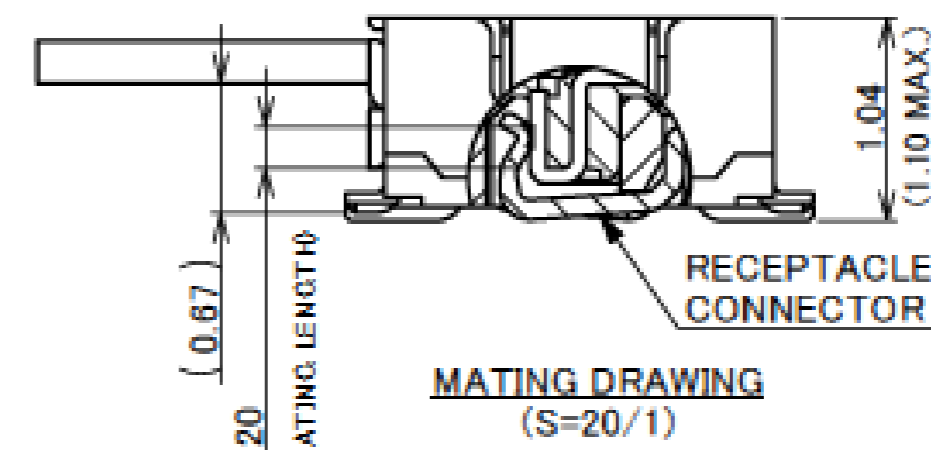

POSITION OF CONCAVE①
30P : 2, 6, 8, 12, BLANK PIN, 19, 23, 25, 29 pos. (9 POSITIONS)
34P : 4, 8, 10, 14, BLANK PIN, 21, 25, 27, 31 pos. (9 POSITIONS)
40P : 6, 8, 12, 14, 18, 23, 25, 29, 33, 35 pos. (10 POSITIONS)
50P : 6, 8, 12, 14, 18, 22, BLANK PIN, 29, 33, 37, 39, 43, 45 pos. (13 POSITIONS)

PART NO.	CONTACT MATERIAL
20533-0**E	PHOSPHOR BRONZE
20533-0**E-01	CORSON ALLOY

NO.	DISCRIPTION	MATERIAL	FINISH , REMARKS
4	VACUUM CLIP	LCP	UL94V-0, BEIGE
3	SHELL	PHOSPHOR BRONZE	Au 0.02 μ m MIN. OVER Ni 1.00 μ m MIN.
2	COTANCT	SEE ABOVE TABLE.1	CONTACT AREA : Au 0.1 μ m MIN. OVER Ni 1.00 μ m MIN. SOLDERING AREA : Au 0.05 μ m MIN. OVER Ni 1.00 μ m MIN.
1	HOUSING	LCP	UL94-0, BLACK

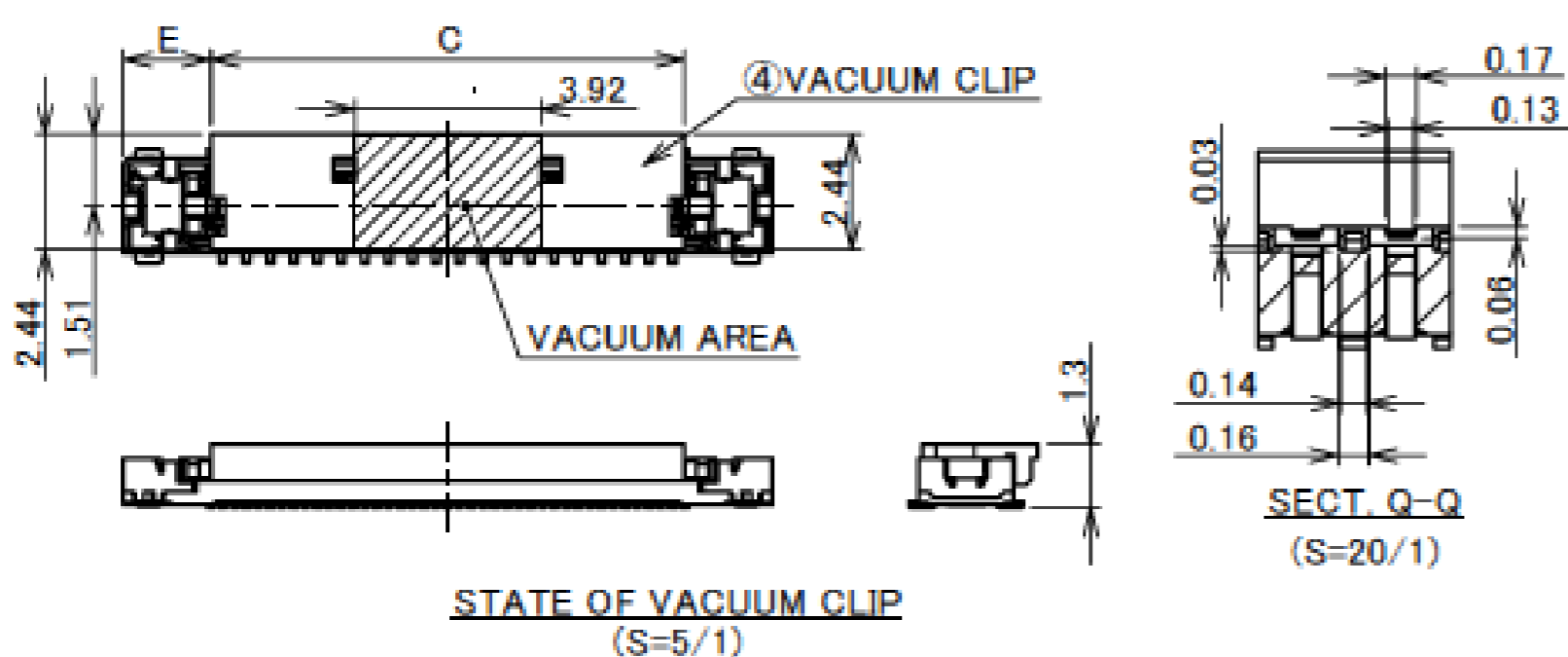

Receptacle Assembly

PART No.	Pos
20533-030E-**-**	30
20533-034E-**-**	34
20533-040E-**-**	40
20533-050E-**-**	50

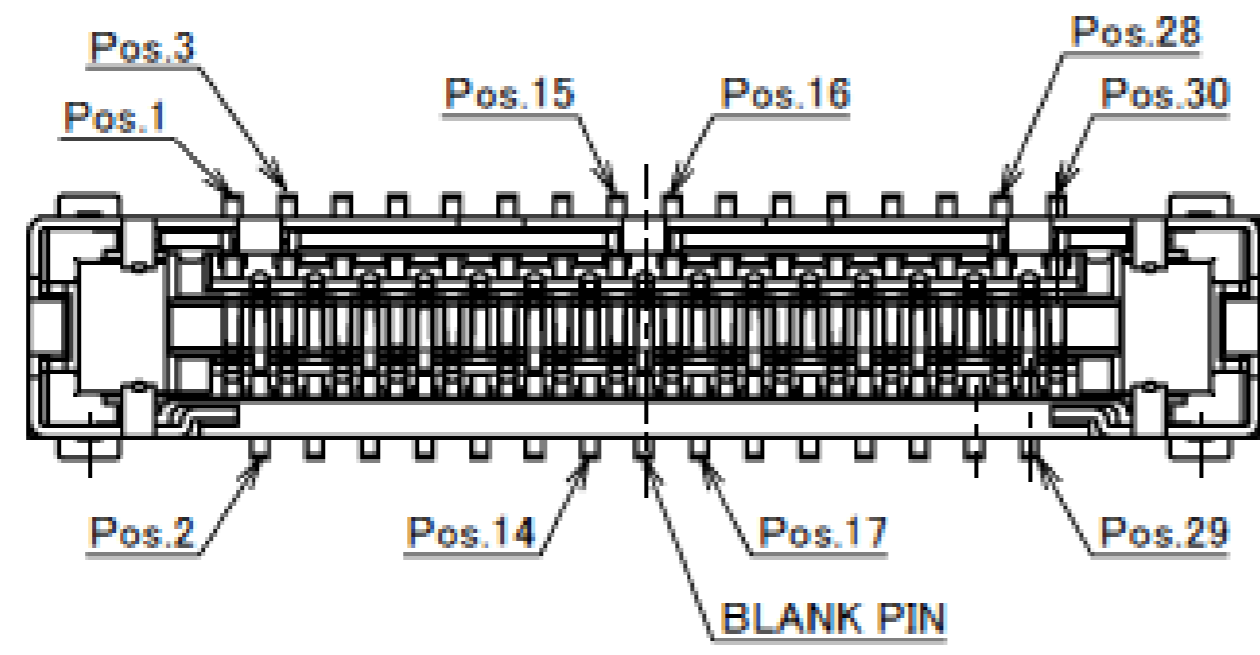

30P CONTACT LAYOUT
(S=10/1)

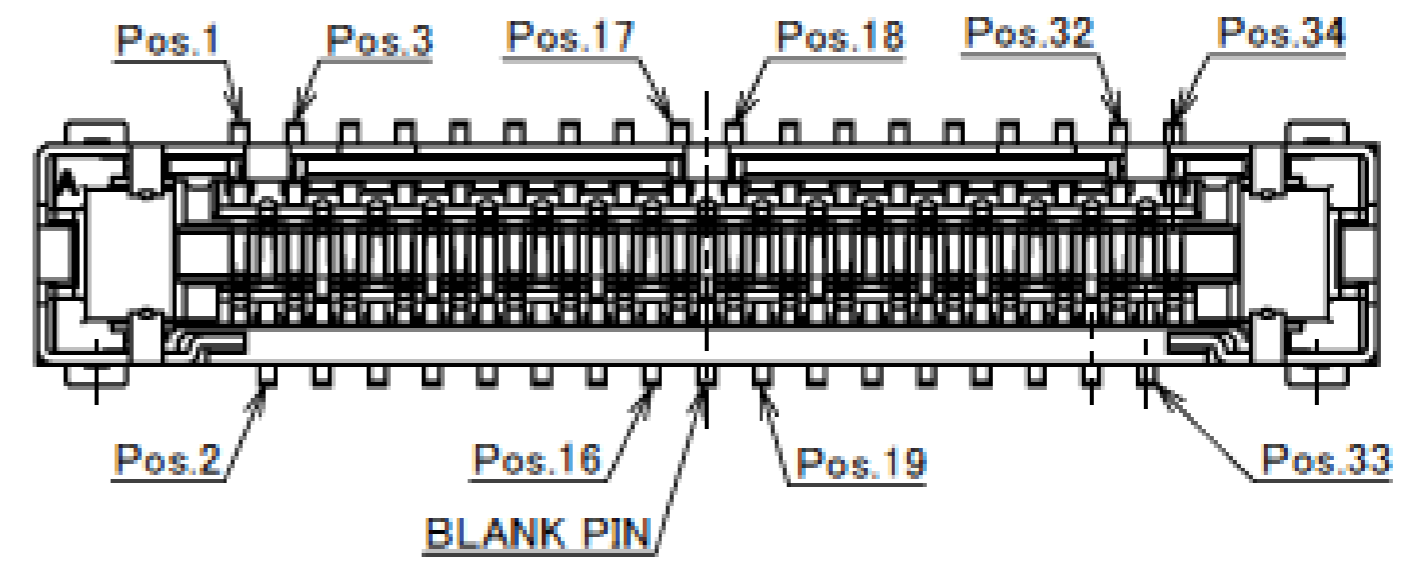

34P CONTACT LAYOUT
(S=10/1)

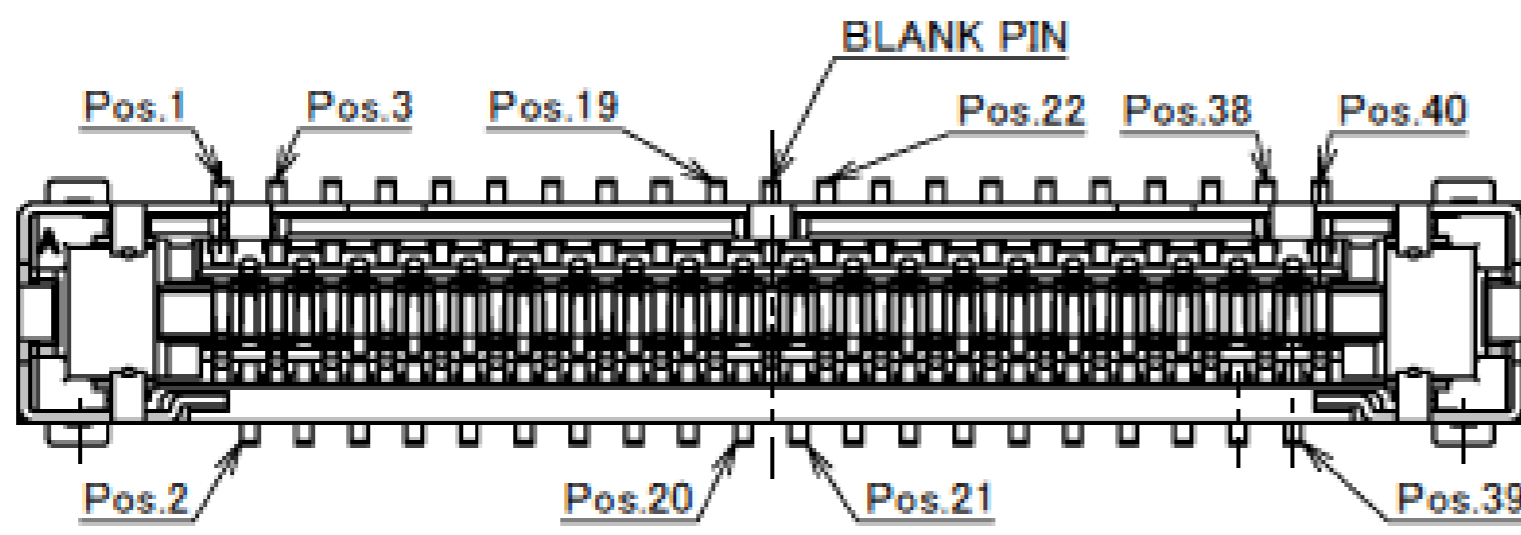

40P CONTACT LAYOUT
(S=10/1)

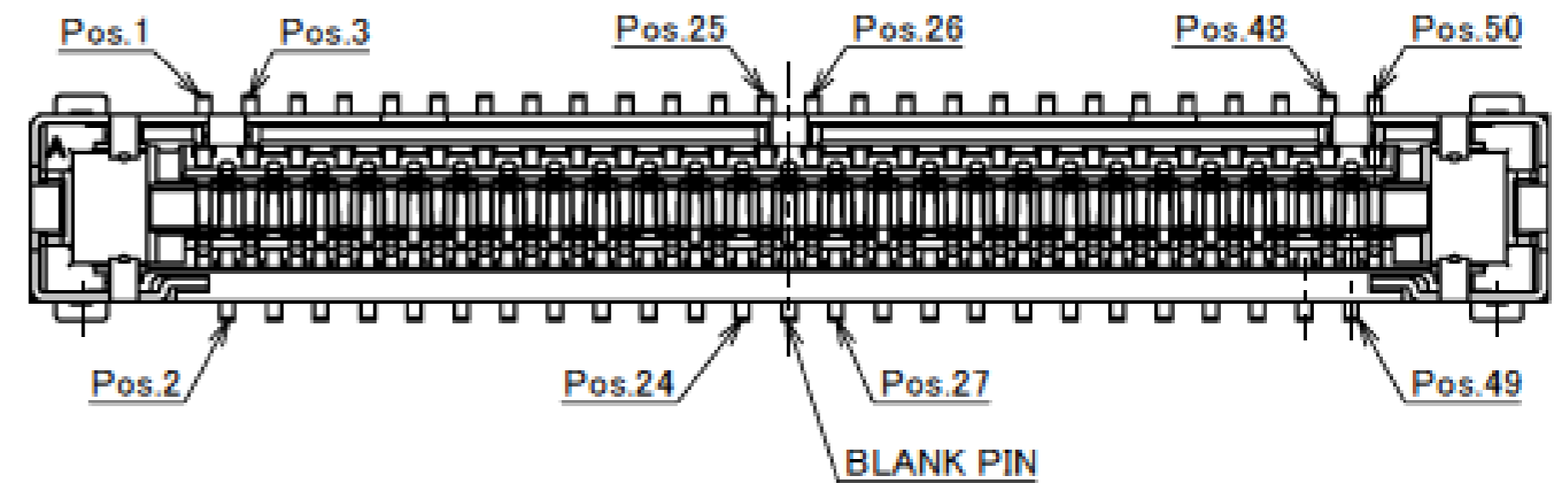

50P CONTACT LAYOUT
(S=10/1)

Rev.15

PART No.	Pos	B	D	F
20533-030E-**-**	30	7.50	10.11	8.30
20533-034E-**-**	34	8.50	11.11	9.30
20533-040E-**-**	40	10.00	12.61	10.80
20533-050E-**-**	50	12.50	15.11	13.30

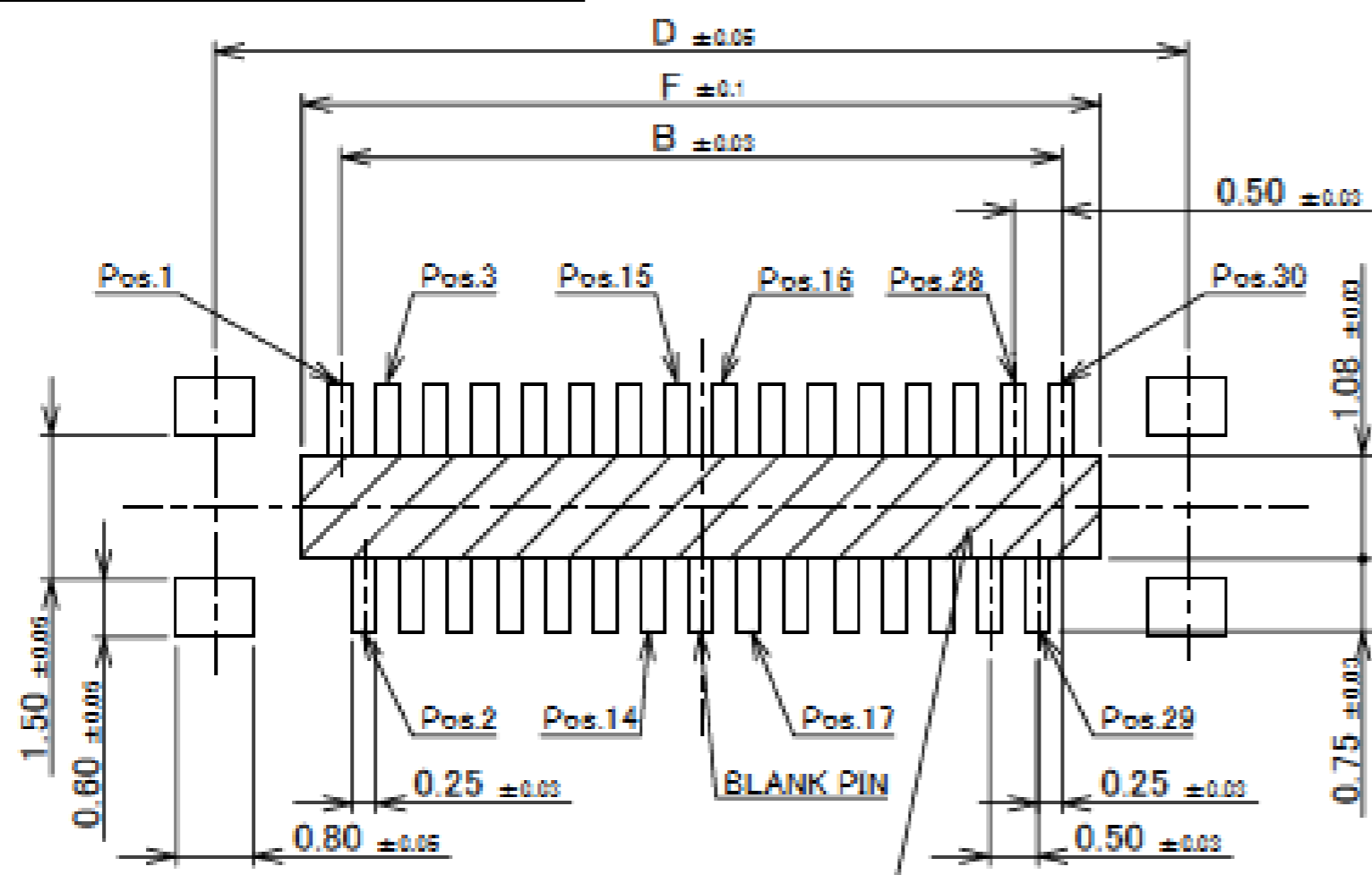

30P RECOMMENDED FOOTPRINT PATTERN LAYOUT

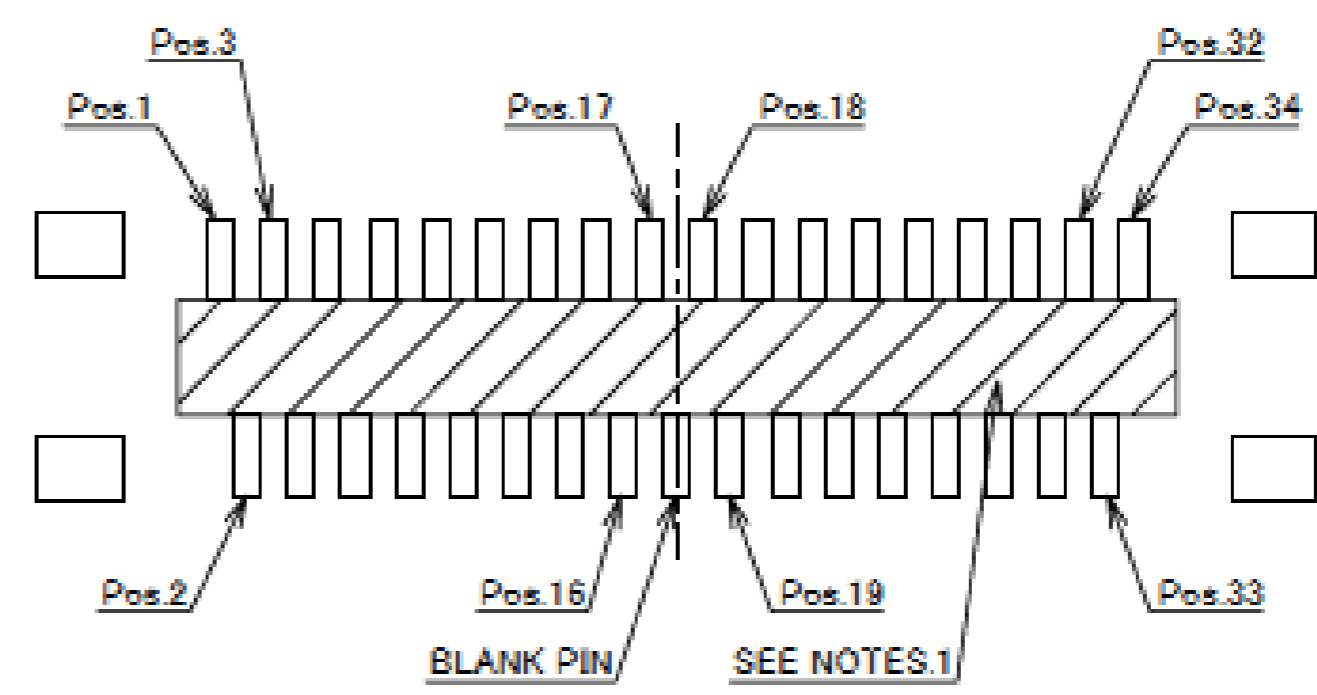

34P RECOMMENDED FOOTPRINT PATTERN LAYOUT

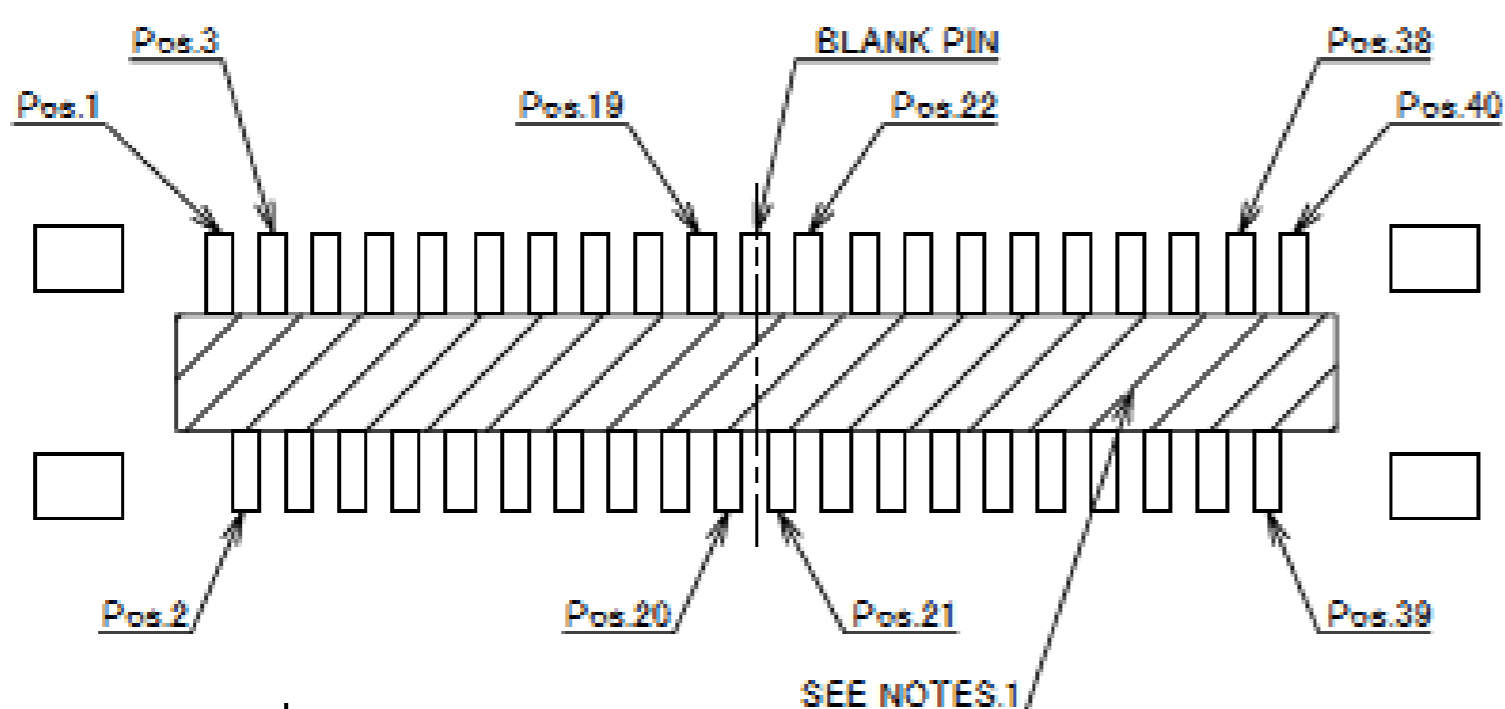

40P RECOMMENDED FOOTPRINT PATTERN LAYOUT

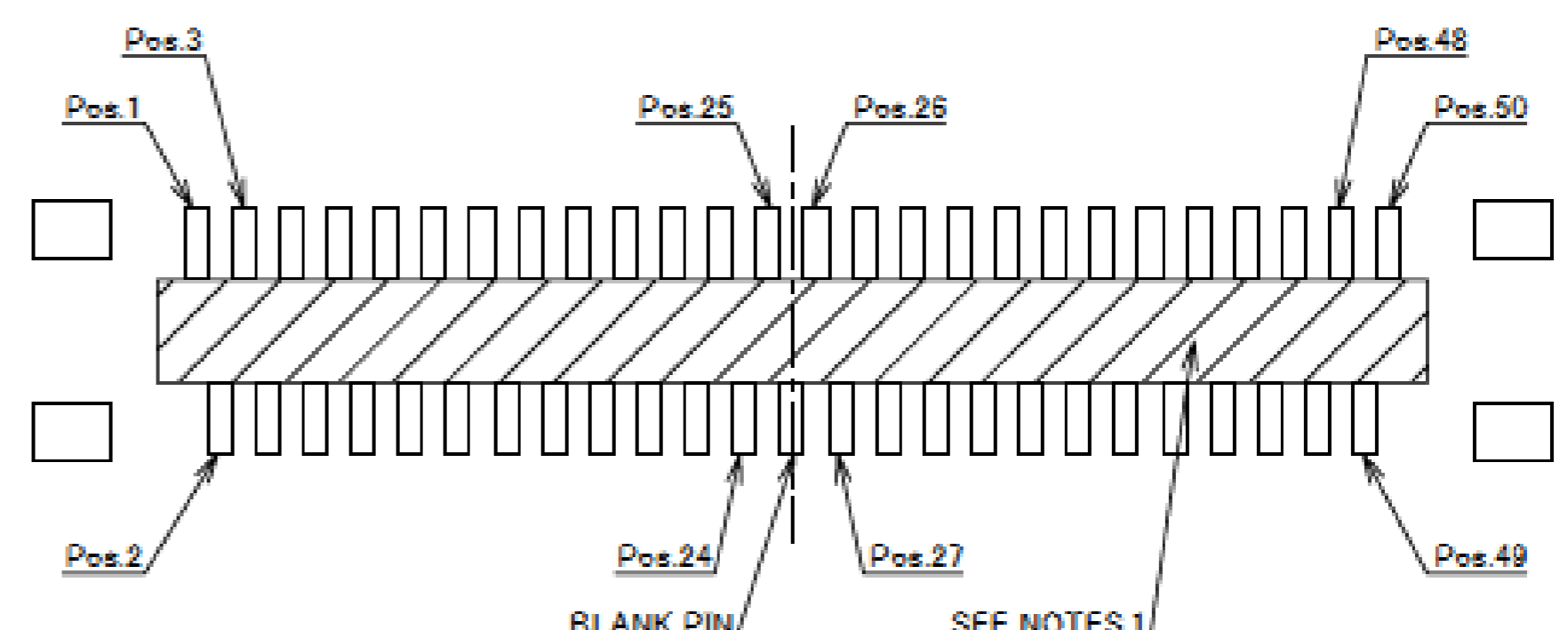

50P RECOMMENDED FOOTPRINT PATTERN LAYOUT

NOTES
1. SOLDER RESIST SHALL BE APPLIED TO THIS AREA.

Rev.15

Receptacle Assembly

PART No.	Pos	B	D
20533-030E-**-	30	7.50	10.11
20533-034E-**-	34	8.50	11.11
20533-040E-**-	40	10.00	12.61
20533-050E-**-	50	12.50	15.11

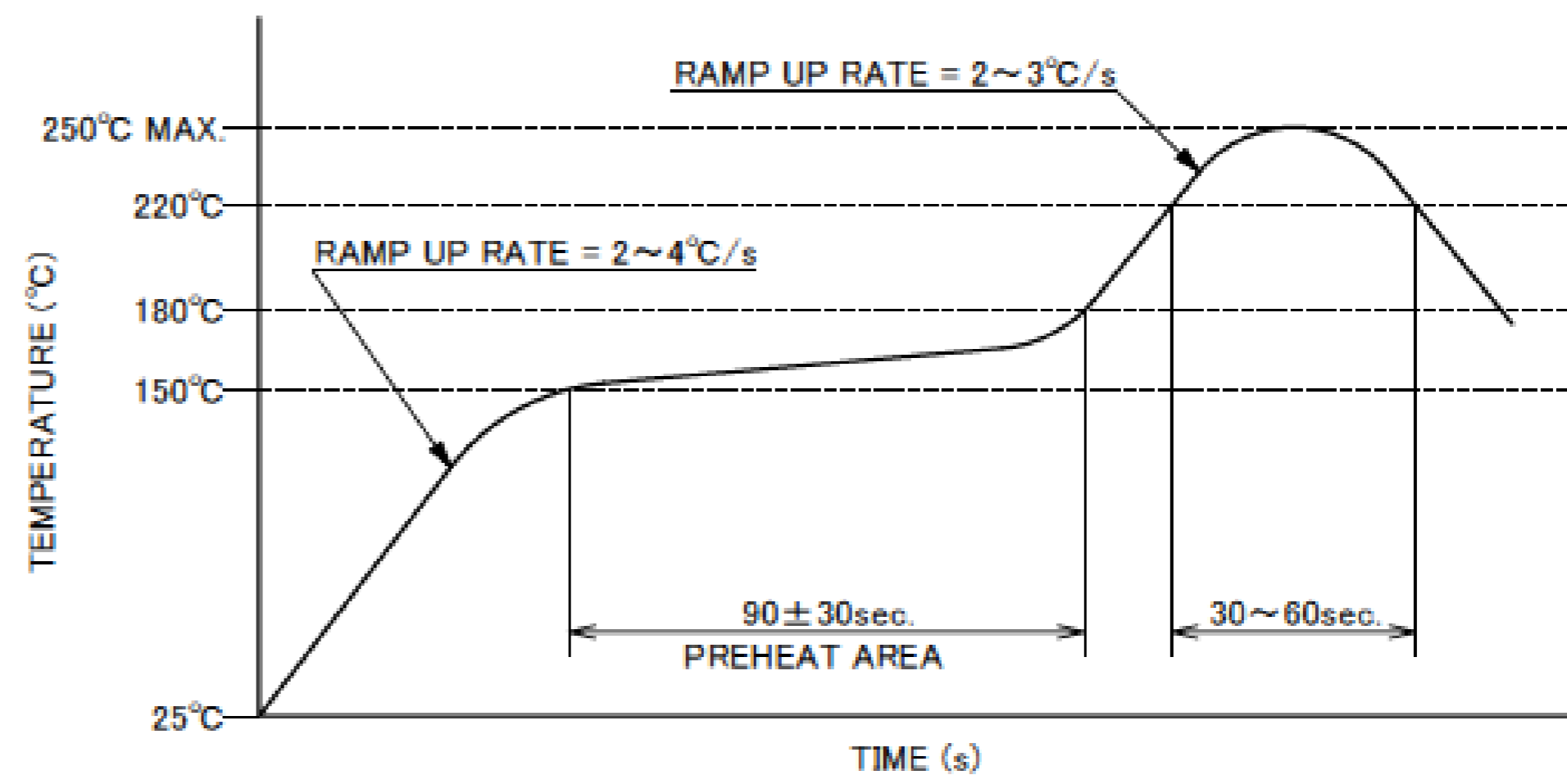
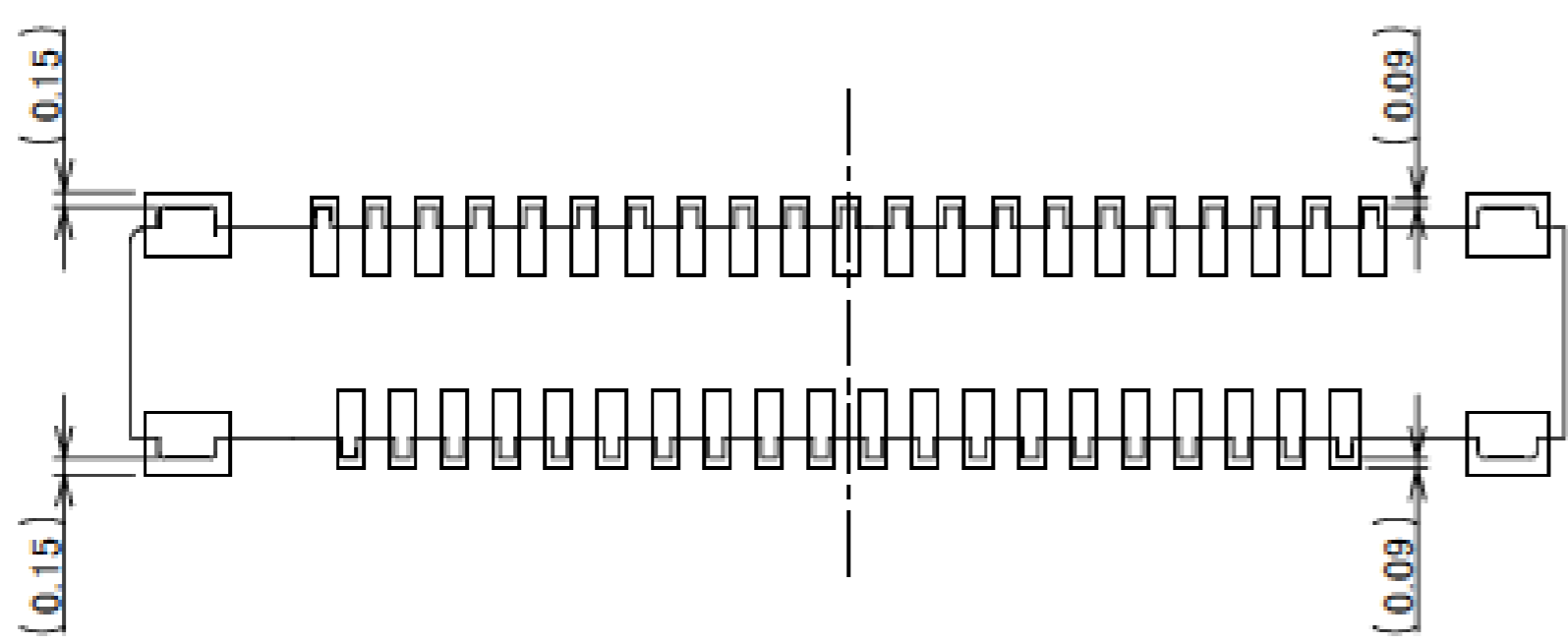
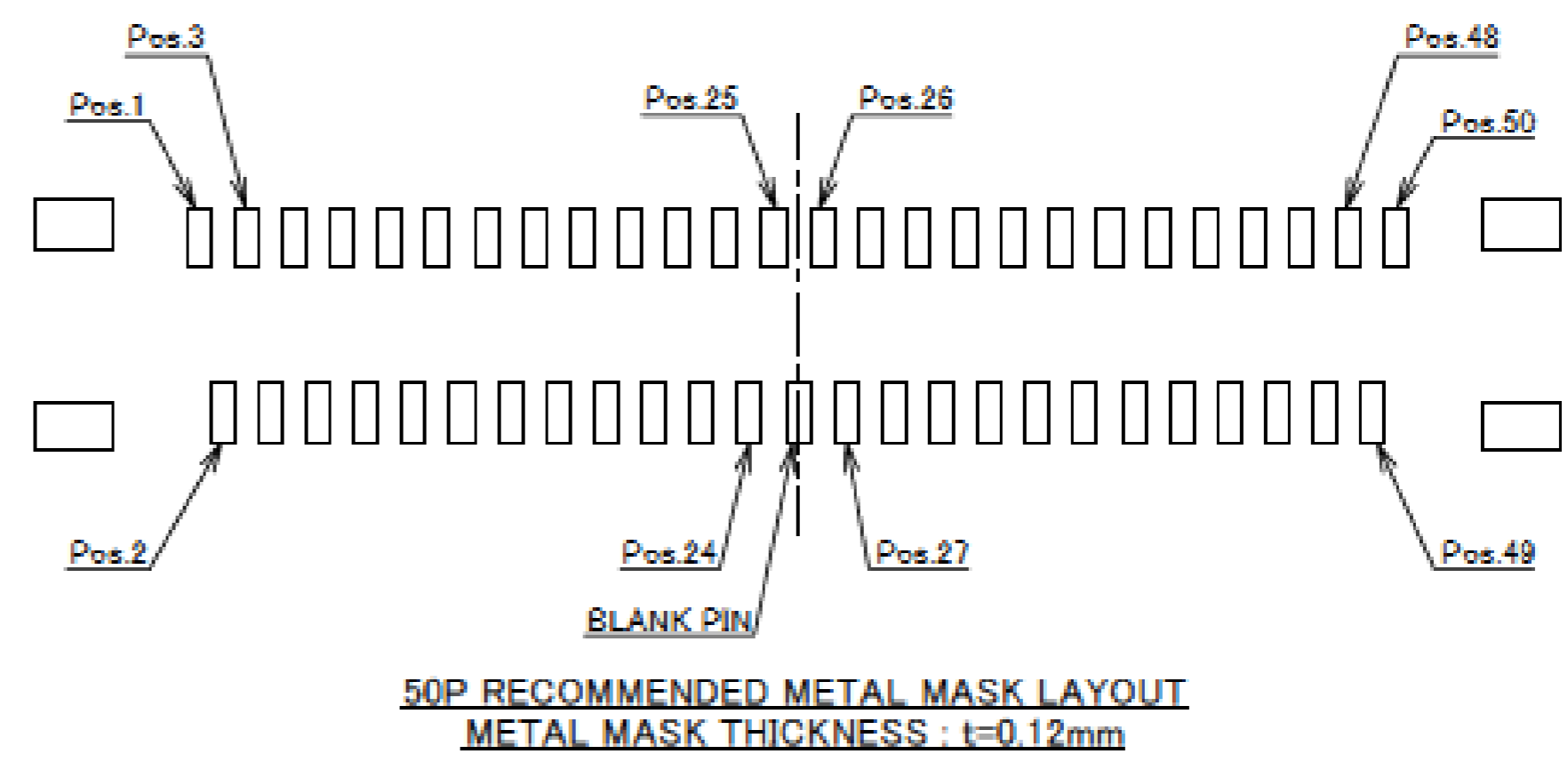
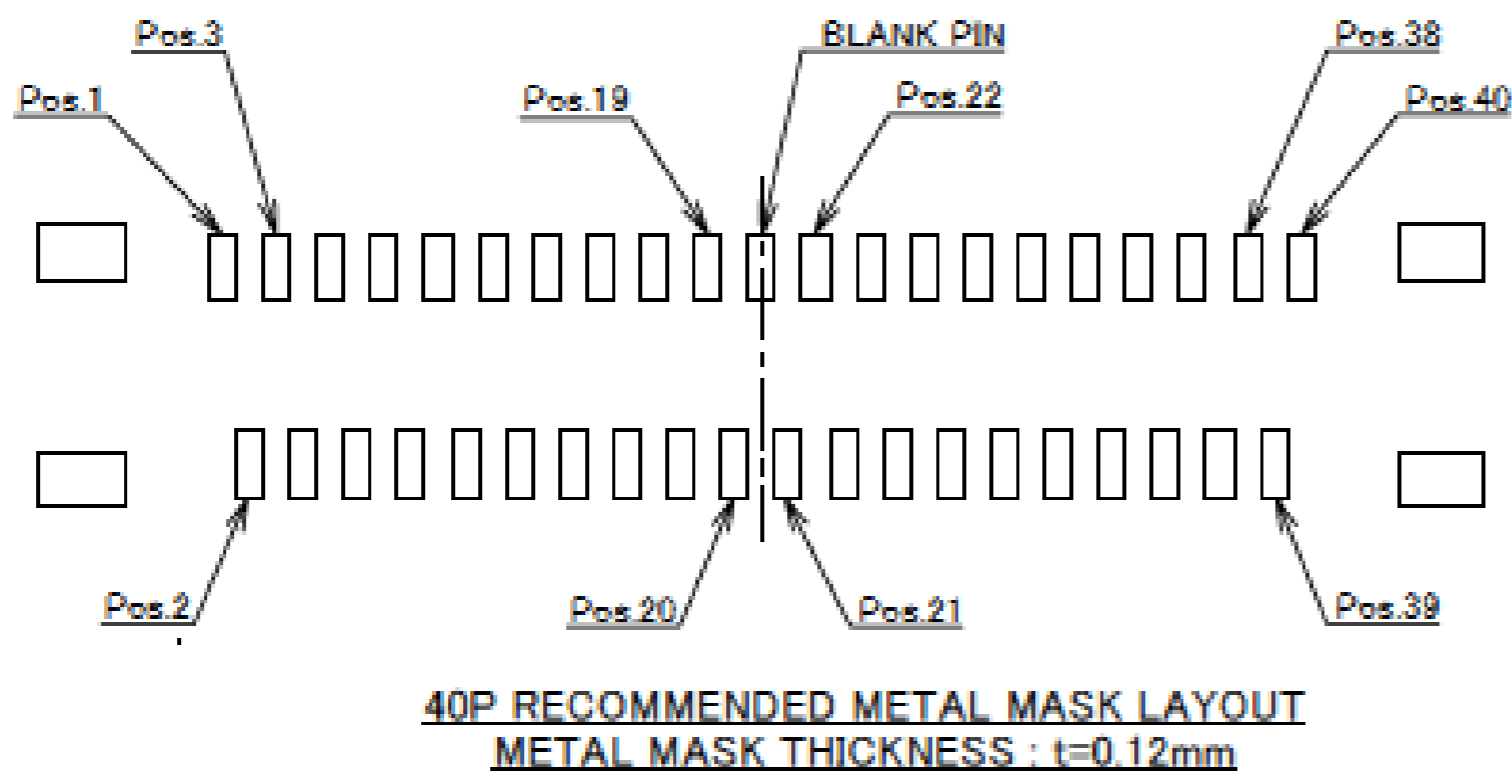
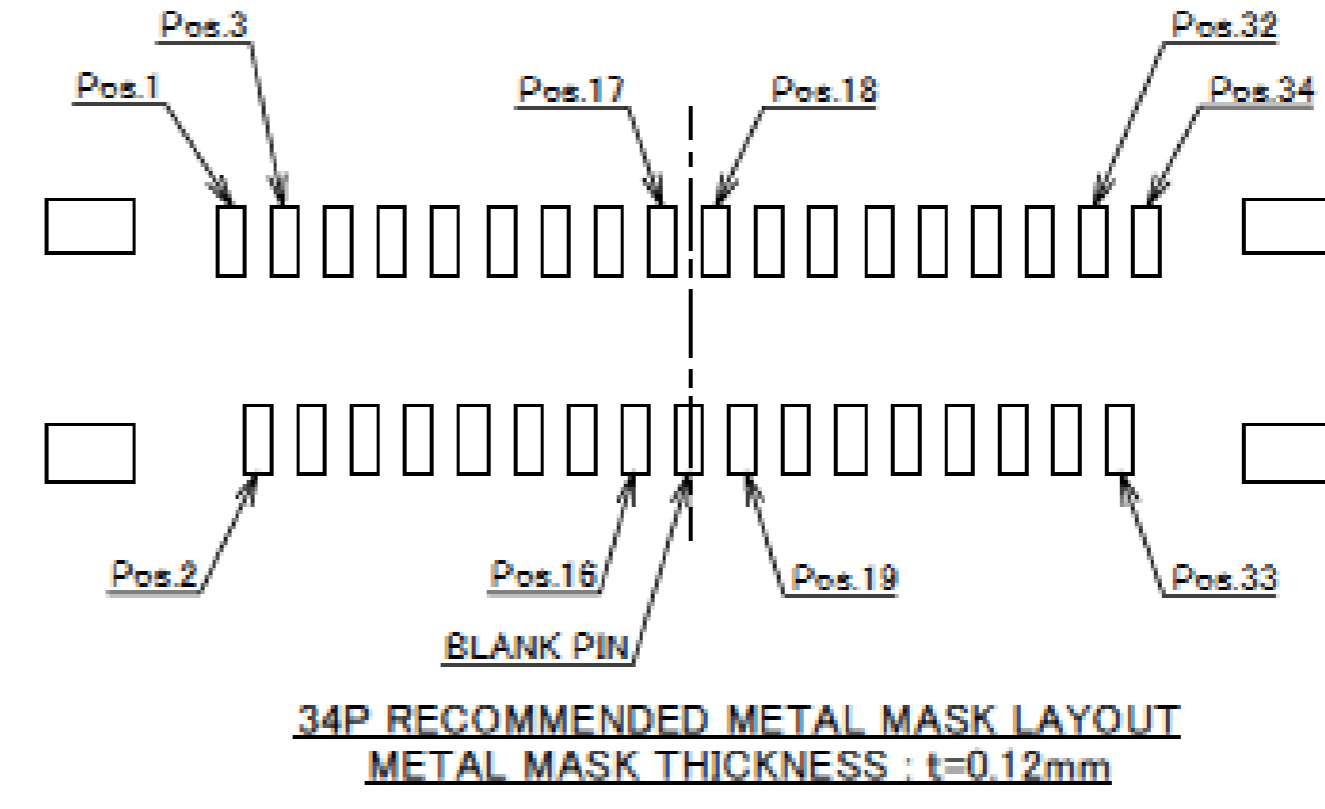
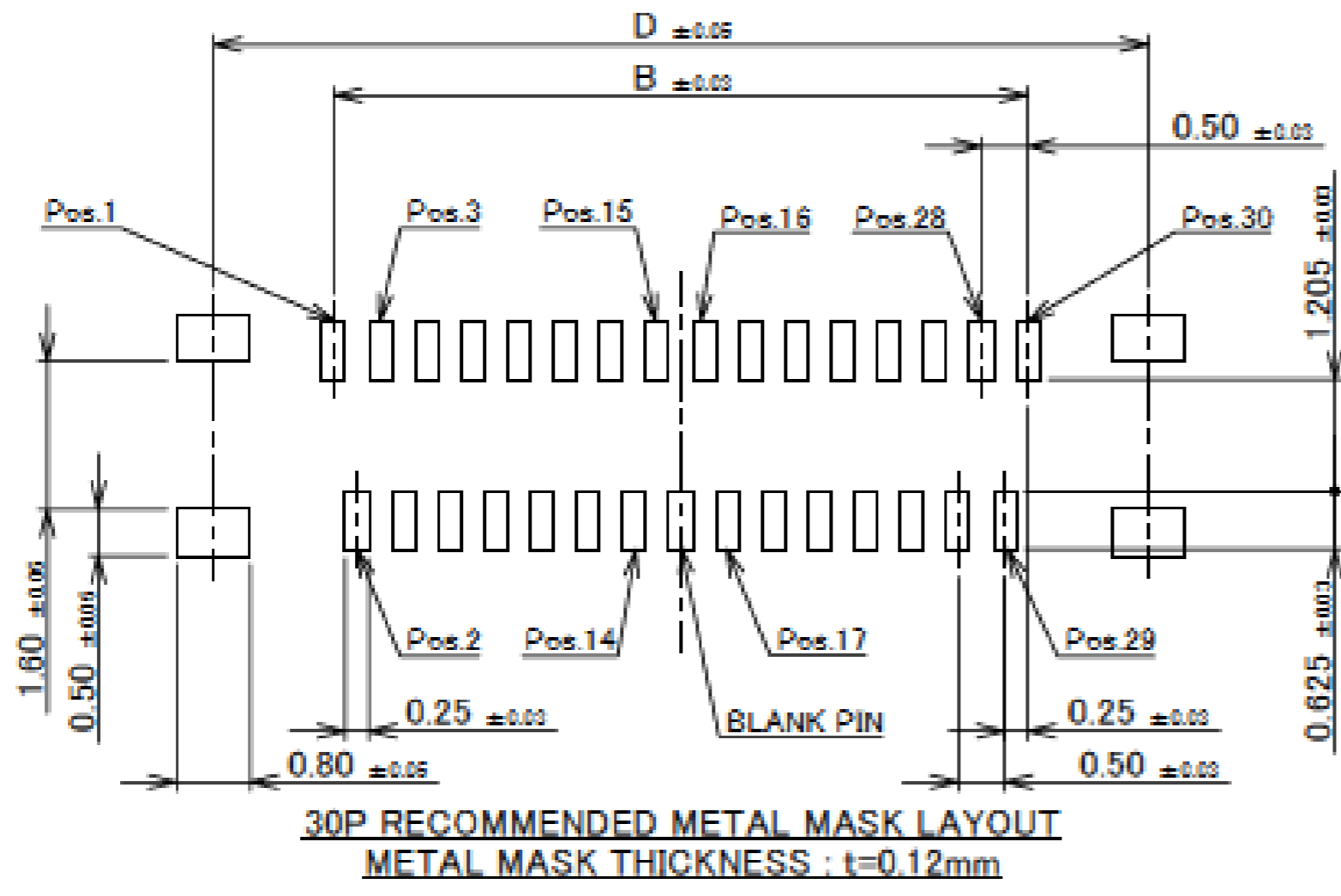

REFLOW TEMPERATURE PROFILE
SENJU METAL INDUSTRY CO., LTD. : M705-SHF(Sn96.5 Ag3.0 Cu0.5)

Receptacle Assembly

ITEMS	SPECIFICATION
APPLICABLE CABLE	MICRO-COAXIAL CABLE : AWG# 44 ,46 DISCRETE WIRE : AWG#39
RATING VOLTAGE	50V AC (PER CONTACT PIN)
RATING AMPERAGE (FOR CONTACT)	CONTACT MATERIAL : PHOSPHOR BRONZE (PLUG : 20531-0**T-02 ,RECEPTACLE : 20533-0**E) 0.50A AC/DC [AWG#39] (PER CONTACT PIN / UP TO 6 CONTACTS) 0.15A AC/DC [AWG#44] 0.10A AC/DC [AWG#46] CONTACT MATERIAL : CORSON ALLOY (PLUG : 20531-0**T-12 ,RECEPTACLE : 20533-0**E-01) 0.50A AC/DC [AWG#39] (PER CONTACT PIN / UP TO 8 CONTACTS) 0.19A AC/DC [AWG#44] 0.14A AC/DC [AWG#46]
OPERATING TEMPERATURE	233~358K(-40°C~+85°C)
OPERATING HUMIDITY	75% MAX.(NON-CONDENSING)
CONTACT RESISTANCE	INITIAL : 450mohm MAX.(AWG#39) 1080mohm MAX.(AWG#44) 1880mohm MAX.(AWG#46) AFTER TEST : \leq 40mohm MAX.
GROUND SHELL RESISTANCE	INITIAL : 100mohm MAX. / AFTER TEST : \leq 40mohm MAX.
INSULATION RESISTANCE	INITIAL : 100Mohm MIN. / AFTER TEST : 100Mohm MIN.
DIELECTRIC WITHSTANDING VOLTAGE	AC100V 1min
DURABILITY	20 CYCLES
MATING FORCE (INITIAL / AFTER TEST)	30P : 26.4N MAX. 34P : 27.6N MAX. 40P : 29.4N MAX. 50P : 32.4N MAX.
UNMATING FORCE (INITIAL / AFTER TEST)	30P : 1.5N MIN. 34P : 1.9N MIN. 40P : 2.5N MIN. 50P : 3.5N MIN.
CABLE RETENTION FORCE	30P : 15.0N MIN. 34P : 17.0N MIN. 40P : 20.0N MIN. 50P : 25.0N MIN.
COPLANARITY	0.10mm MAX.
PRODUCT SPECIFICATION	PRS-1555
TEST REPORT	TR-10051
INSTRUCTION MANUAL	HIM-10001
PACKING STANDARD	300-874
APPEARANCE CRITERIA No.	QLS-A***

Rev.15

Custom Connectors Available

 RF Connector

MHF® series



 CABLINE® series
Micro-coaxial/Twinax/
Discrete Wire Connector



 Optical Module

LIGHTPASS® series



NOVASTACK® series

 Board-to-Board Connector



 Power Connector/
Terminal

AP series

ISH® series



MINIFLEX® series

EVAFLEX® series

 FPC FFC Connector



Inquiry



MINIDOCK® series

 I/O Connector



I-PEX, MHF, CABLINE, LIGHTPASS, NOVASTACK, ISH, IARPB, MINIFLEX, EVAFLEX, MINIDOCKS and ZenShield are registered trademarks of I-PEX Inc. Please note that the contents in the catalog might be changed without prior notification. I-PEX Inc. assumes no responsibility for any inaccuracies or obligation to update information on these documents. Please be sure to read and understand the latest "Precautions for Use" and "Instruction Manual" before you use our products. We shall not be responsible for any defects, damages or troubles in case you use our products without following the precautions for use. Please feel free to contact our sales representatives when you use our products for any applications that require very high reliability and safety, or that relate to human life (ex. nuclear power control, aerospace, transportation, medical equipment, safety equipment etc.).

Contact your sales representative or more detailed information.

www.i-pex.com



I-PEX

© I-PEX Inc. 2024
All rights reserved