

CABLIN[®]-UM

フルシールド、多点グラウンド接点、メカニカルロック付き、高速伝送対応 (20Gbps/lane)、0.4mmピッチ、ライトアングル縦嵌合タイプ細線同軸コネクタ

Product Specifications:

Mating type	Right Angle Vertical	
Board Pitch (mm)	0.4	
Wiping Length (mm)	0.65	
Mated size (mm)	Height	With Lock Cover : 2.2 +/- 0.15
		Without Lock Cover : 2.0 +/- 0.15
		With Pull Tape Holder: 2.2 +/- 0.15
Mated size (mm)	Width	Formula: 5.0 + (0.4 * ? p)
	Depth	5.0 with lock cover
Pin Counts	Range	Up to 60
	Available	30, 40, 50, 60

Applicable Cable Size:

Maximum O.D. (mm)	0.4
Micro-Coaxial for Signal (AWG)	45 ohm: #38 or smaller 50 ohm: #40 or smaller
Twinax (AWG)	#40, #42
Discrete (AWG)	#34 or smaller

Applicable Standards (Reference Only):

USB4/Thunderbolt 4 (20 Gbps/lane), PCIe Gen 4 (16GT/s), eDP HBR 3 (8.1 Gbps)

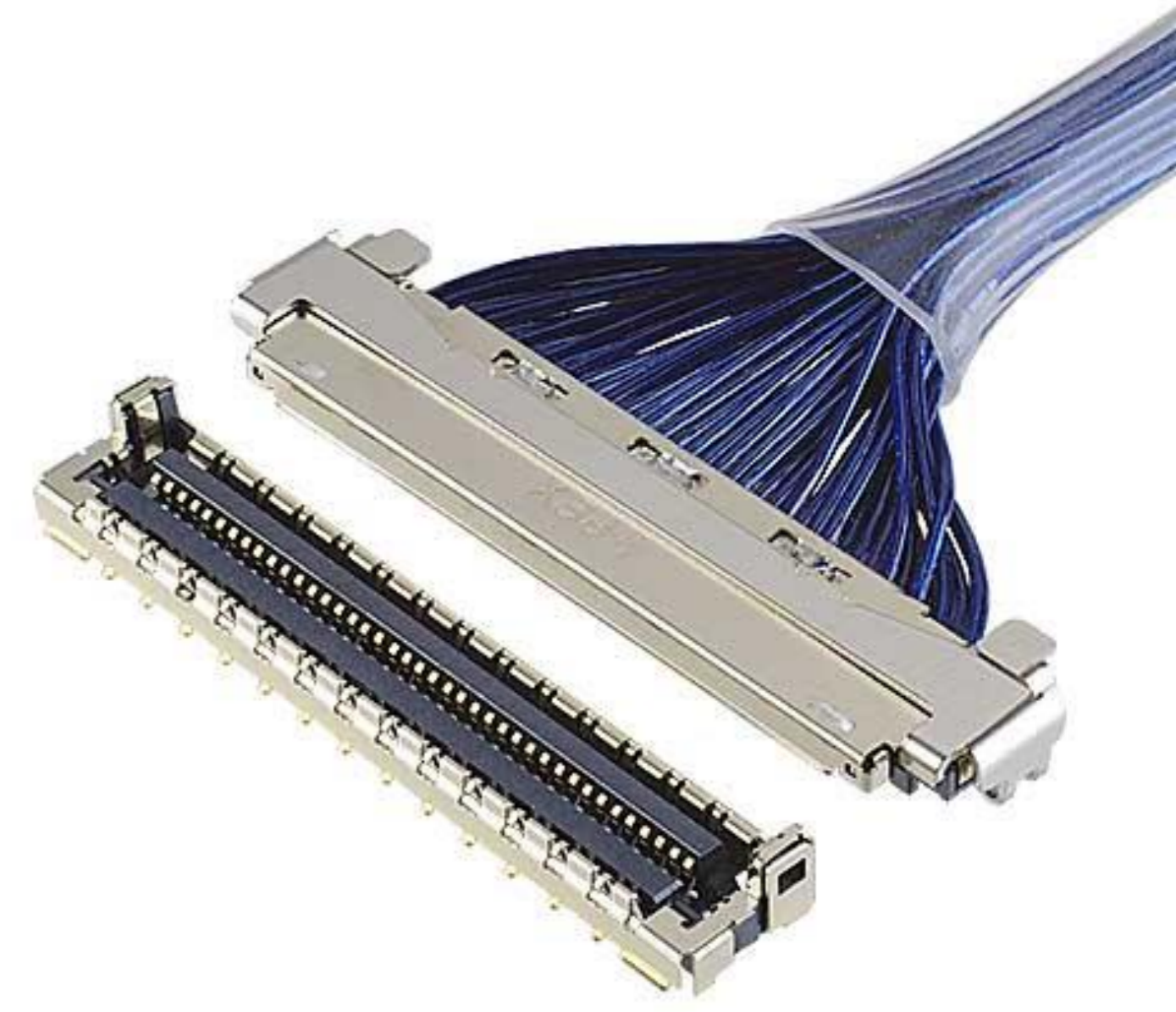

*記載のない極数の対応状況についてはお問い合わせください。

▶ 多点グラウンド接点による360度ZenShield[®]フルシールドでEMI対策

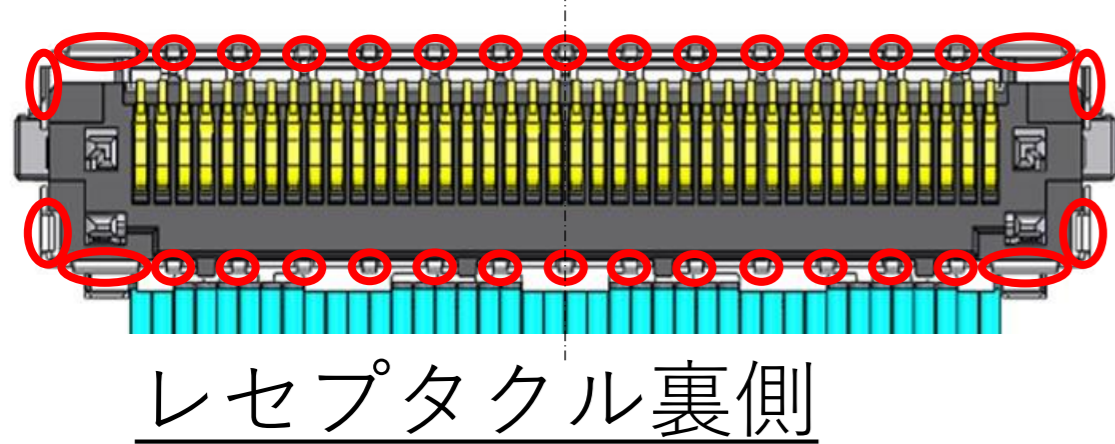

レセプタクル裏側

○ グラウンドSMT点



一般的なコネクタ

EMI

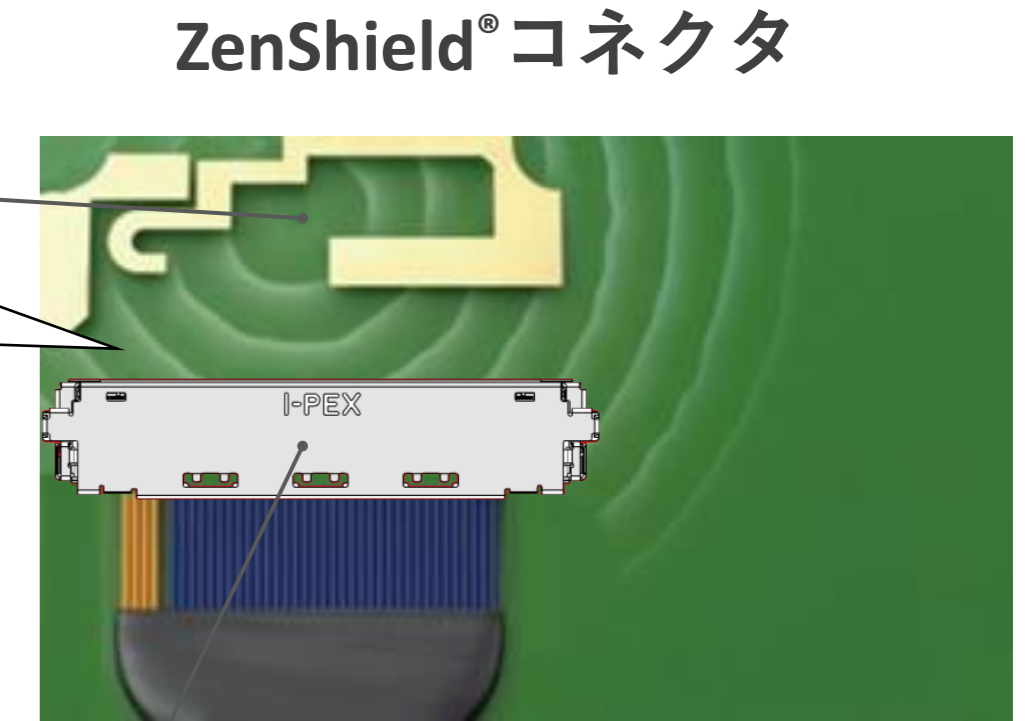

ZenShield[®]コネクタ

EMIを低減

信号伝送接続(EMIノイズ発生源)
ZenShield コネクタは、アンテナ等の放射構造物近くに配置可能

▶ 豊富なバリエーション展開

Lock Cover付---嵌合保持力増強

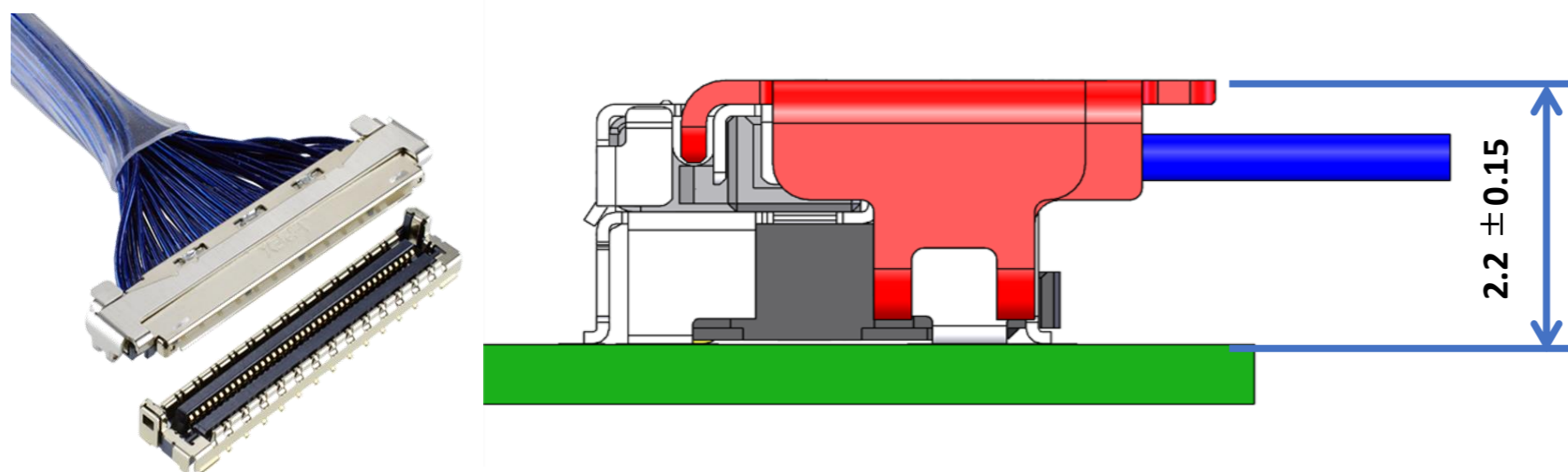

Lock Coverなし---低背

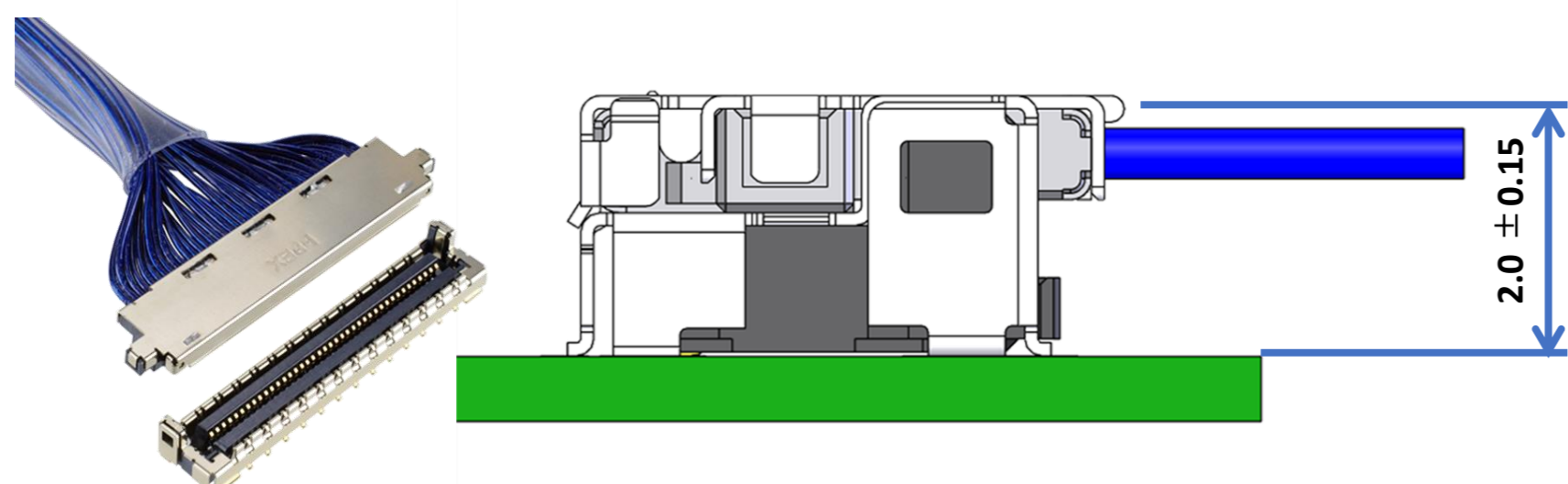

Pull tape holder付き---抜去作業効率向上

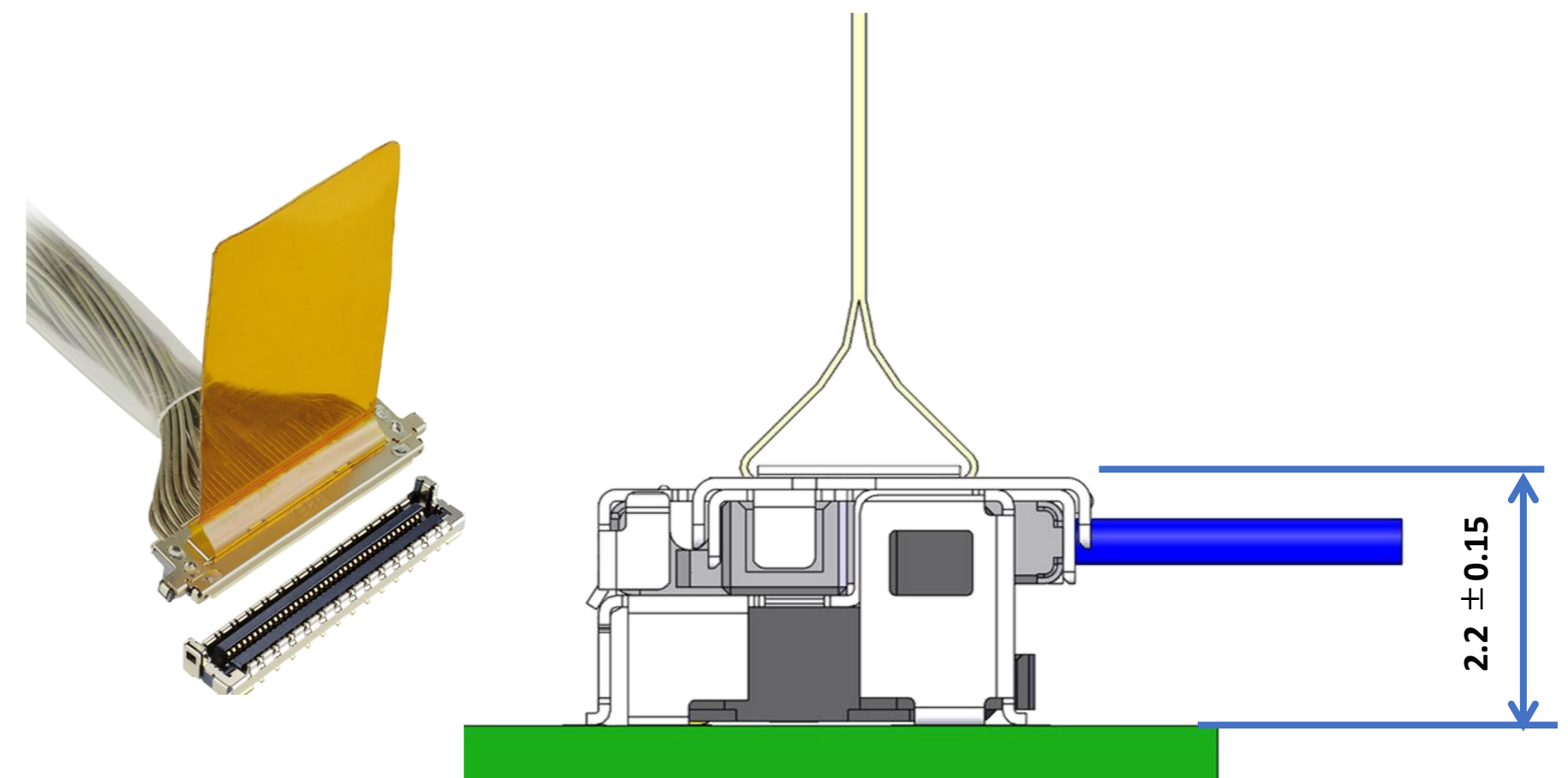

▶ 高いコンタクト接触信頼性

有効嵌合長 : 0.65mm Min.

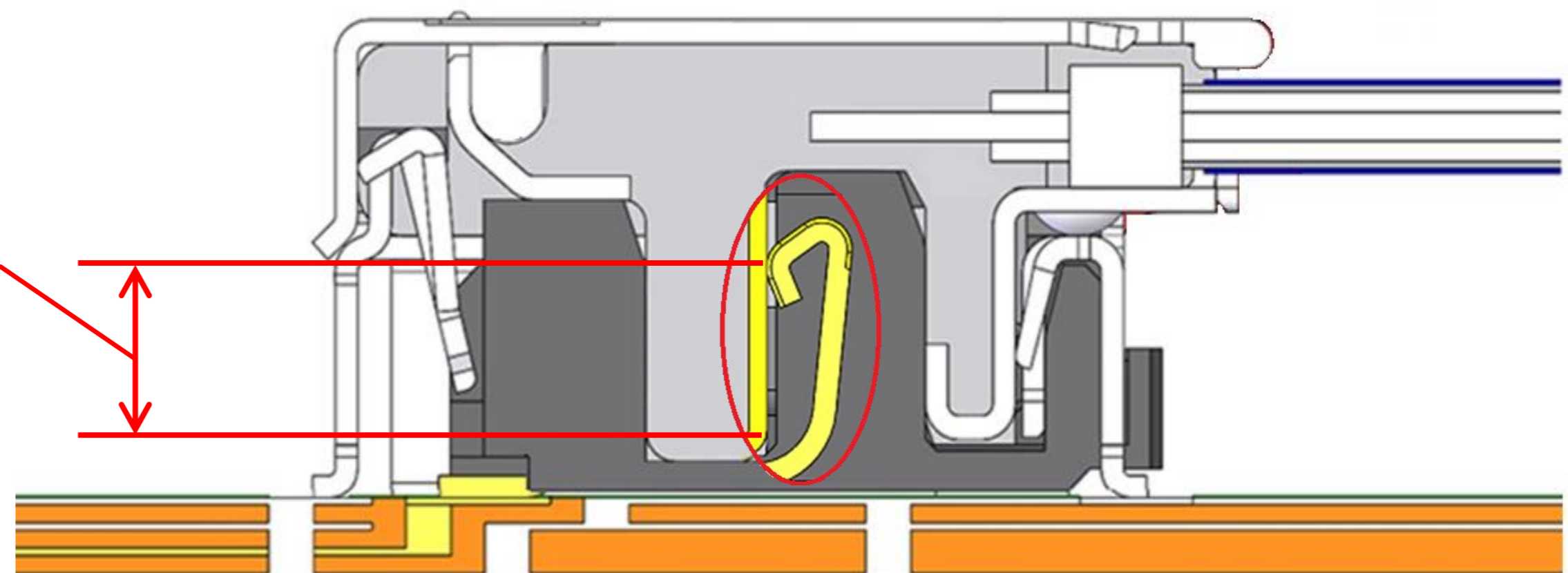

Component Parts Details

Component Parts

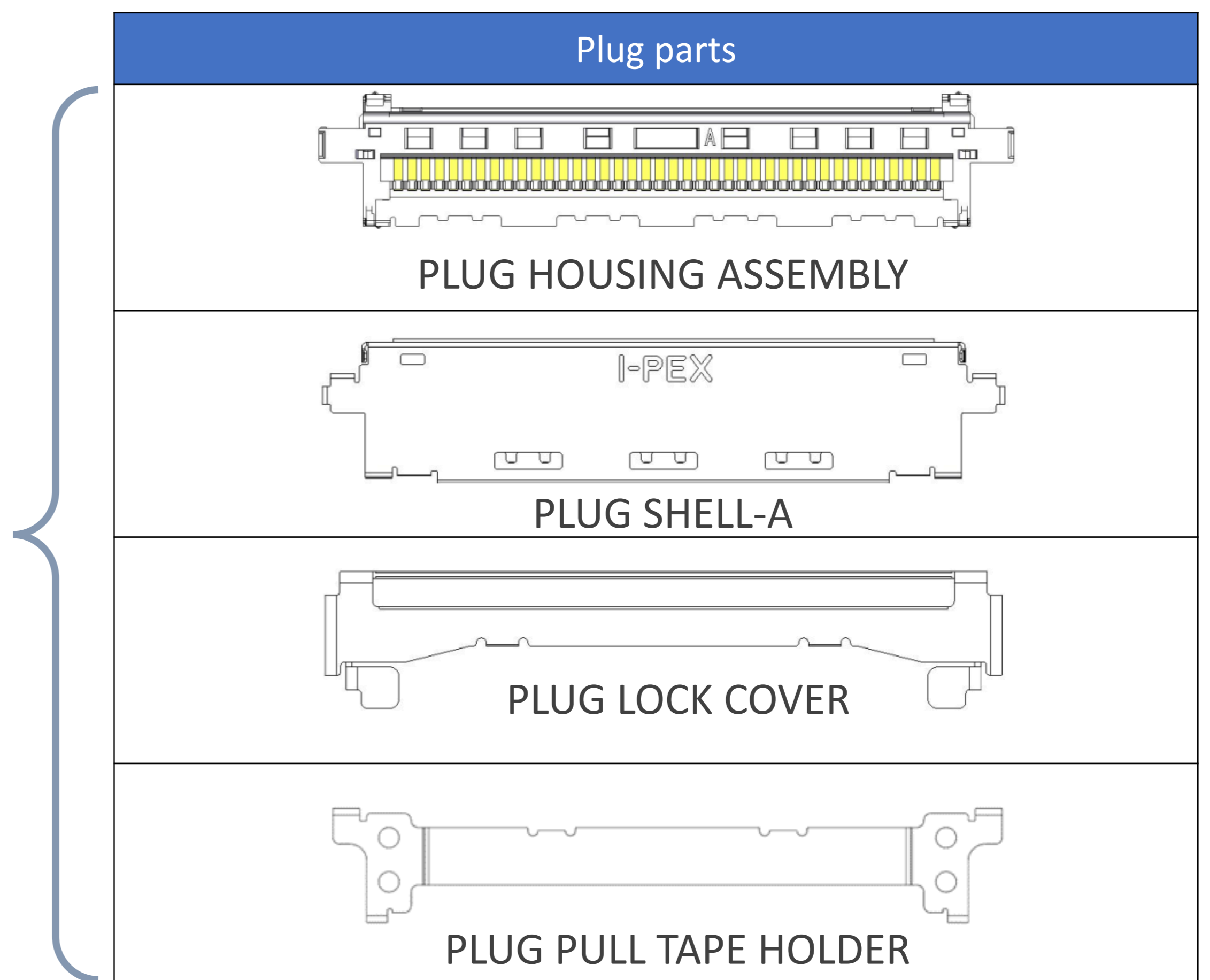
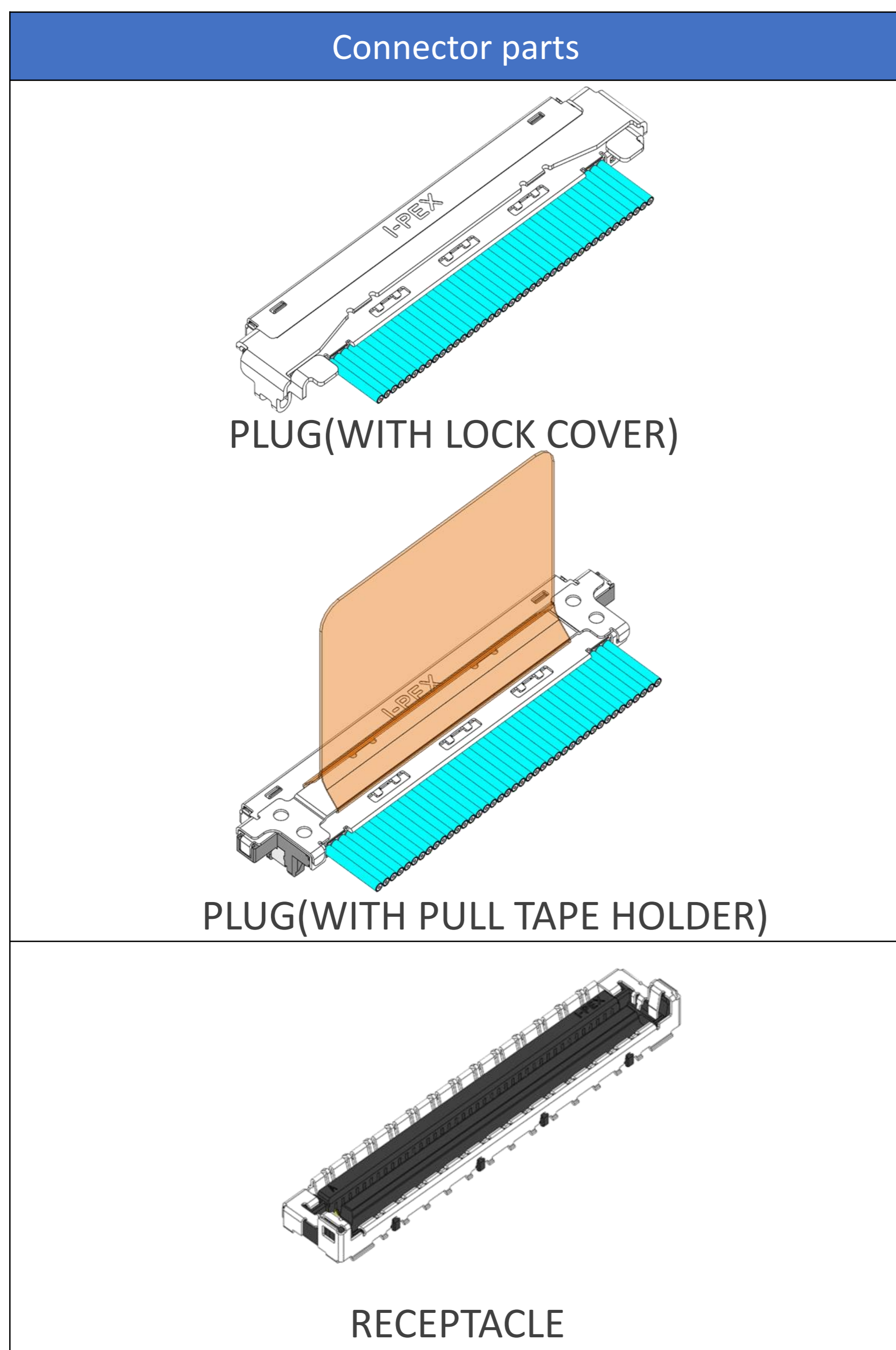

Plug for Cable Assembly

Recommended P/N		20877-0**T-01				
PART NO.	Pos.	A	B	C	D	E
20877-030T-01	30	16.20	13.85	13.65	11.60	17.00
20877-040T-01	40	20.20	17.85	17.65	15.60	21.00
20877-060T-01	60	28.20	25.85	25.65	23.60	29.00

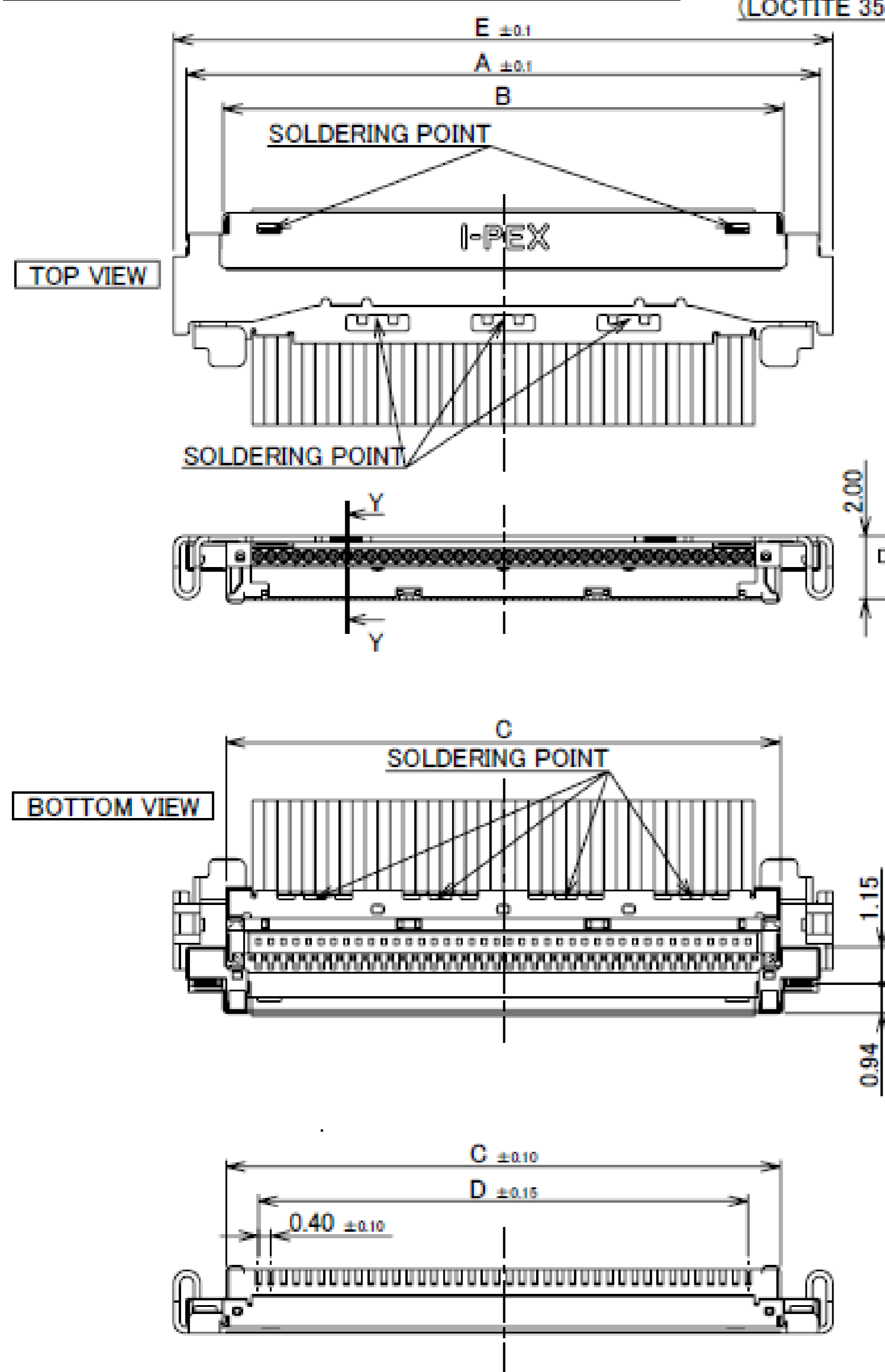

With LOCK COVER

BONDING
(LOCTITE 352 RECOMMENDS)

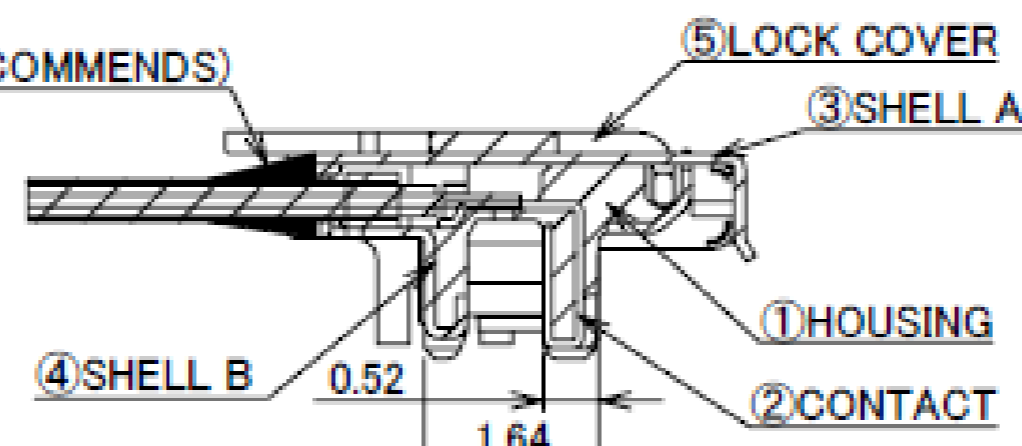

SECT. Y-Y
(S=10/1)

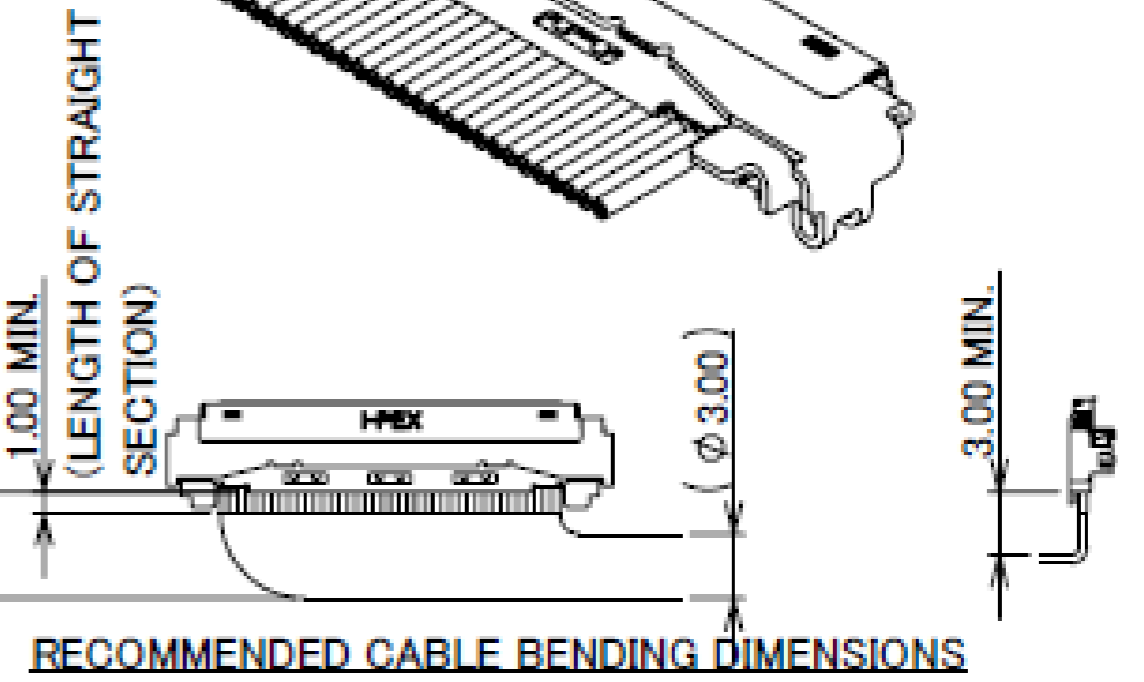
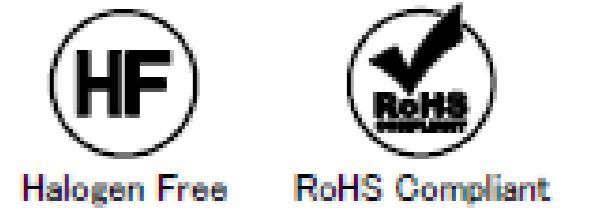
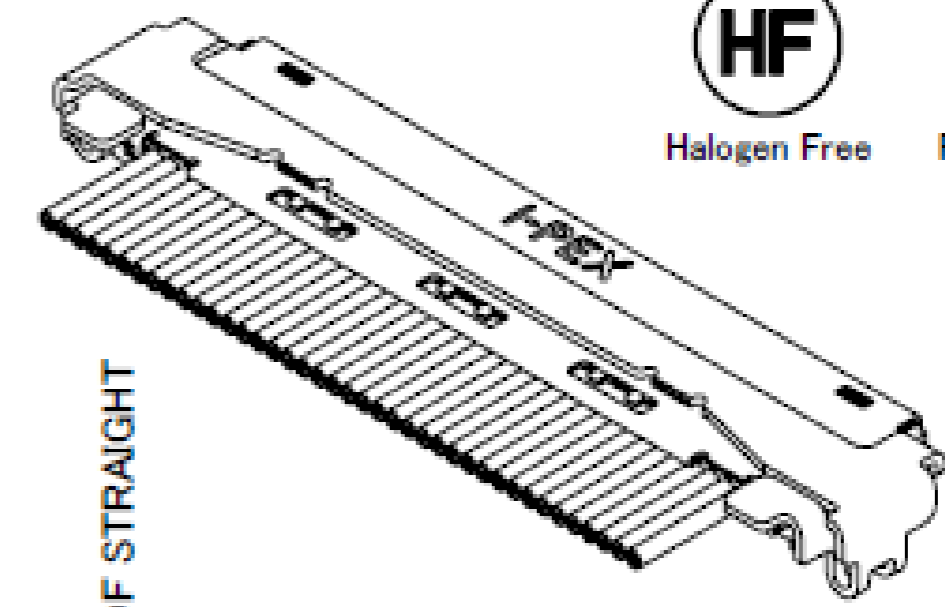
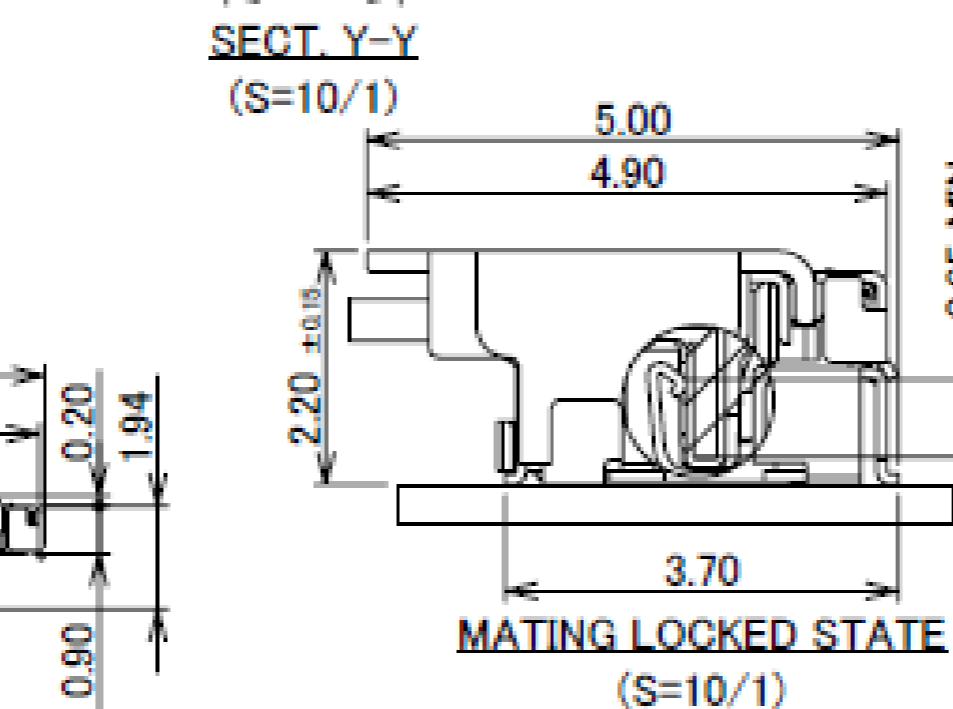

NOTES:
1. THE LOCK COVER MUST BE OPENED AT LEAST 25° TO PROPERLY UNMATE THE PLUG/HARNESS.

5	LOCK COVER	PHOSPHOR BRONZE	ALL OVER Ni 1.0 μm MIN.
4	SHELL B	PHOSPHOR BRONZE	PARTIAL Au 0.003 μm MIN. OVER Ni 1.0 μm MIN.
3	SHELL A	PHOSPHOR BRONZE	PARTIAL Au 0.003 μm MIN. OVER Ni 1.0 μm MIN.
2	CONTACT	CORSON ALLOY	ALL OVER Ni 1.0 μm MIN. CONTACT & SOLDERING AREA : Au 0.03 μm MIN.
1	HOUSING	LCP	UL94V-0 ,BLACK
NO.	DISCRIPTION	MATERIAL	FINISH , REMARKS

Rev.14

Recommended P/N		20877-0**T-01			
PART NO.	Pos.	A	B	C	D
20877-030T-02	30	16.20	13.85	13.65	11.60
20877-040T-02	40	20.20	17.85	17.65	15.60
20877-050T-02	50	24.20	21.85	21.65	19.60
20877-060T-02	60	28.20	25.85	25.65	23.60

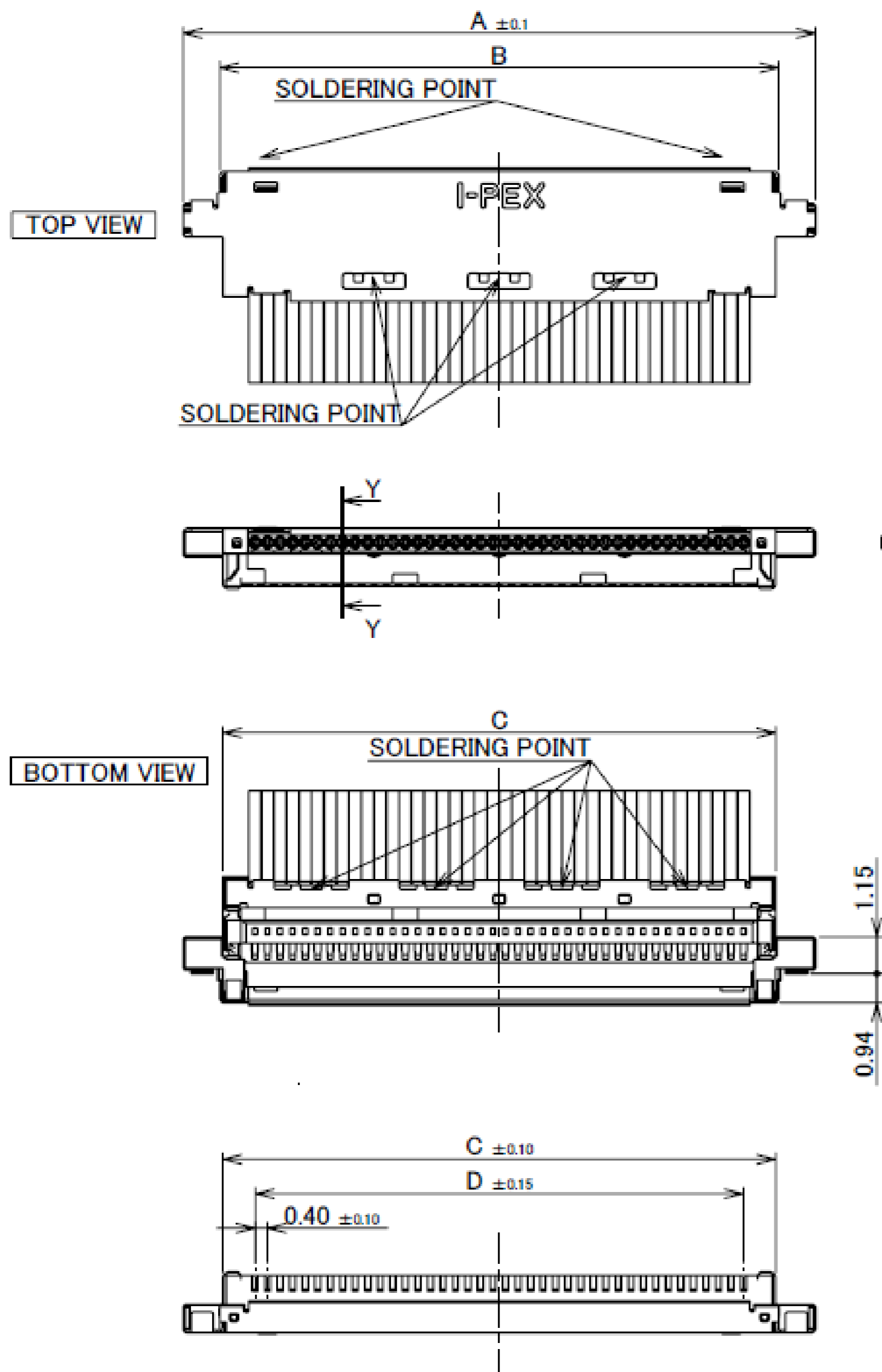

Without LOCK COVER

BONDING
(LOCTITE 352 RECOMMENDS)

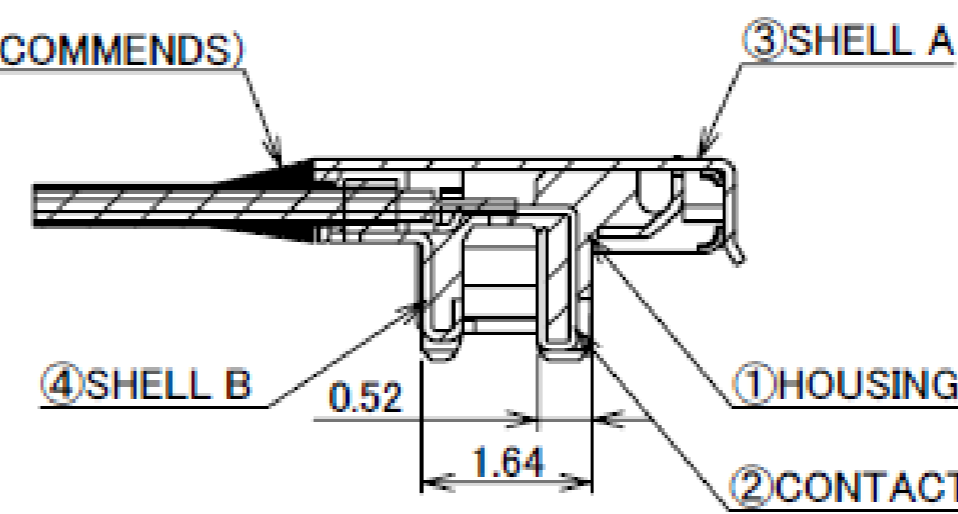

SECT. Y-Y
(S=10/1)

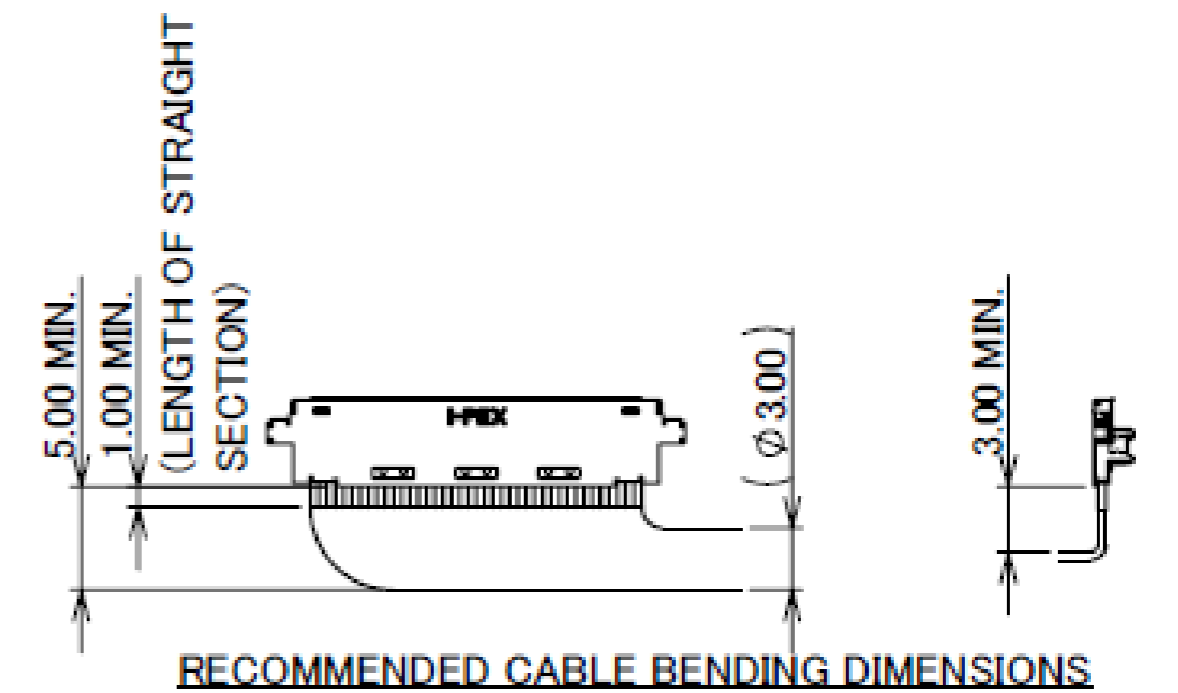
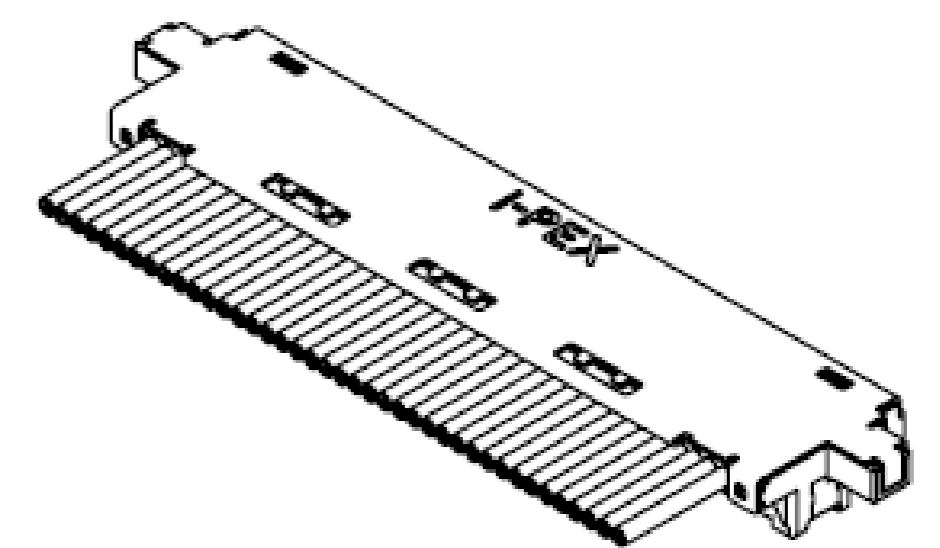
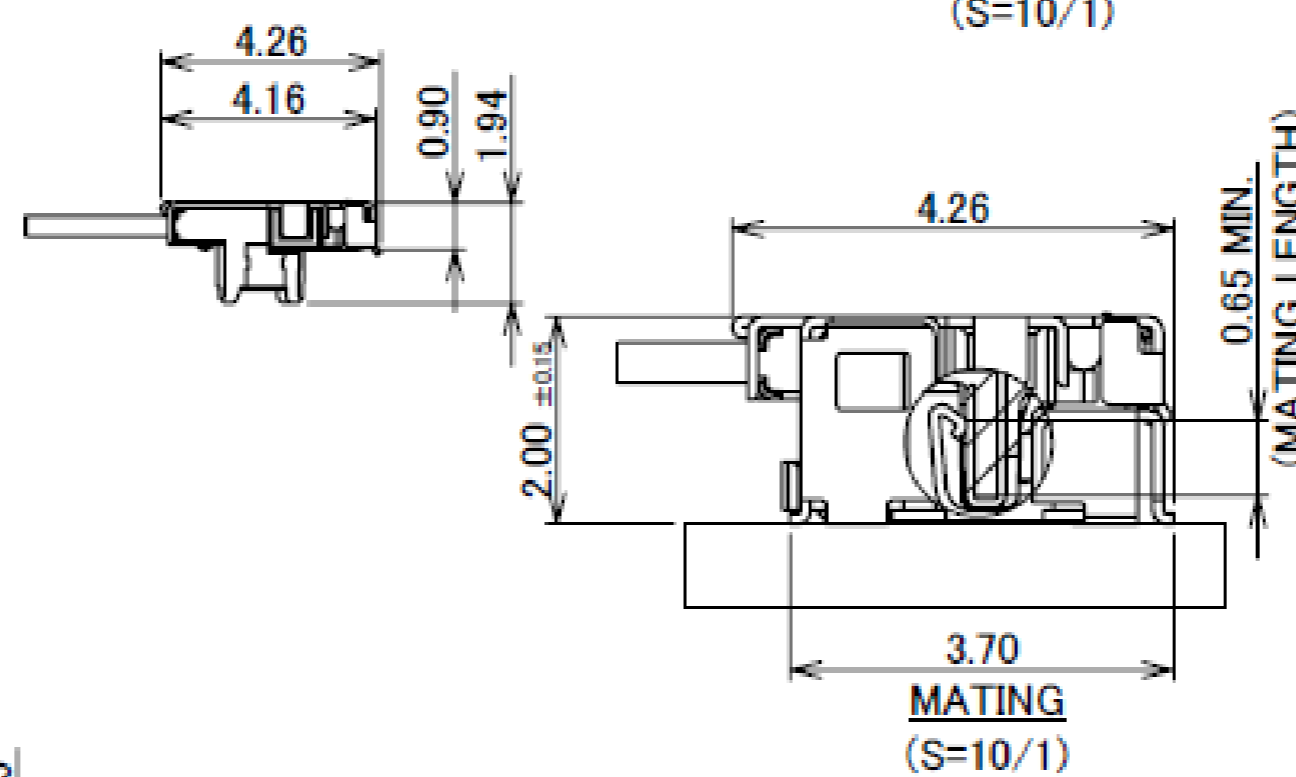

4	SHELL B	PHOSPHOR BRONZE	PARTIAL Au 0.003 μm MIN. OVER Ni 1.0 μm MIN.
3	SHELL A	PHOSPHOR BRONZE	PARTIAL Au 0.003 μm MIN. OVER Ni 1.0 μm MIN.
2	CONTACT	CORSON ALLOY	ALL OVER Ni 1.0 μm MIN. CONTACT & SOLDERING AREA : Au 0.03 μm MIN.
1	HOUSING	LCP	UL94V-0 ,BLACK
NO.	DISCRIPTION	MATERIAL	FINISH , REMARKS

Rev.14

Plug for Cable Assembly

Recommended P/N		20877-0**T-01					
PART NO.	Pos.	A	B	C	D	F	G
20877-030T-03	30	16.20	13.85	13.65	11.60	9.00	10.00
20877-040T-03	40	20.20	17.85	17.65	15.60	13.00	14.00
20877-050T-03	50	24.20	21.85	21.65	19.60	17.00	18.00
20877-060T-03	60	28.20	25.85	25.65	23.60	21.00	22.00

With PULL TAPE HOLDER

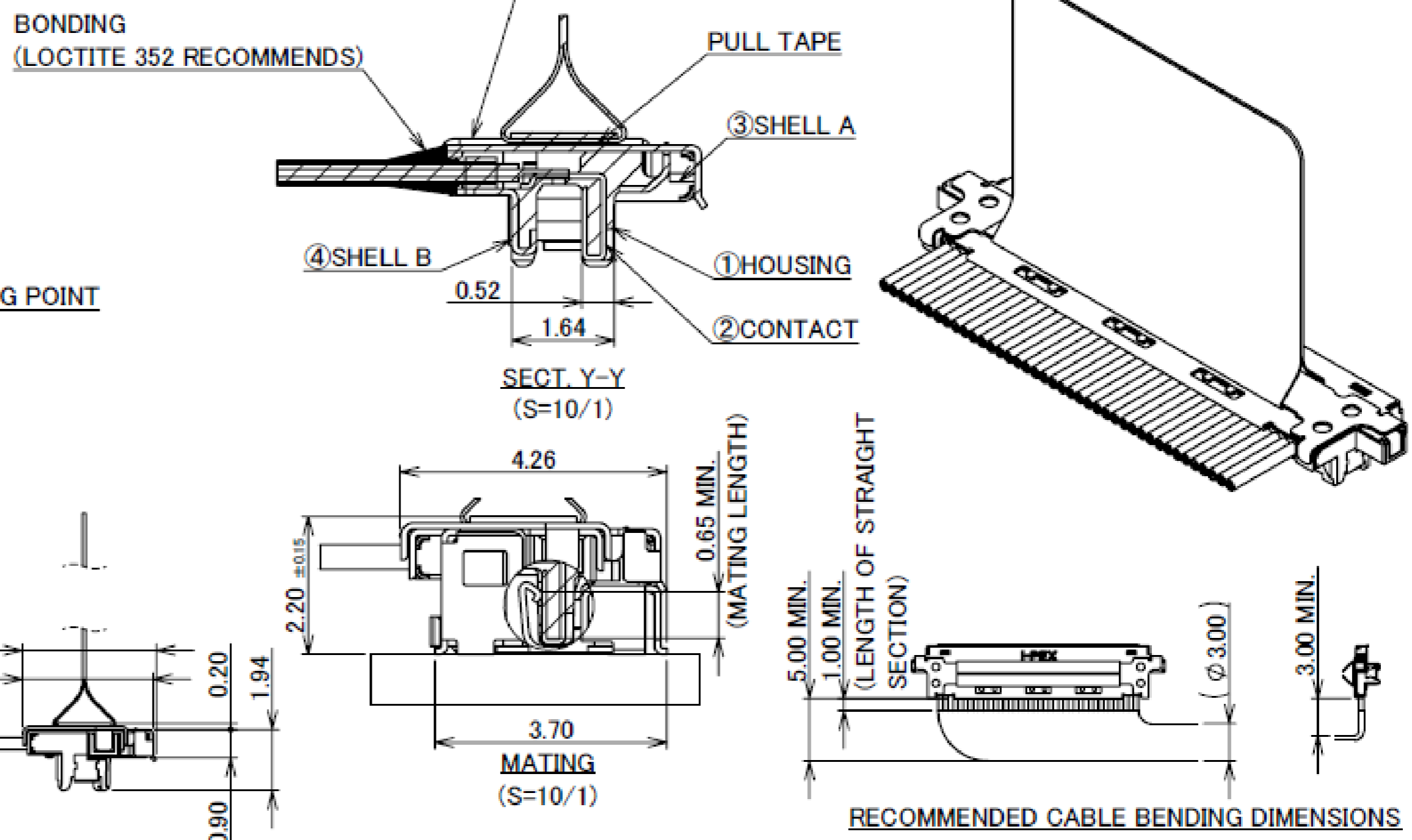
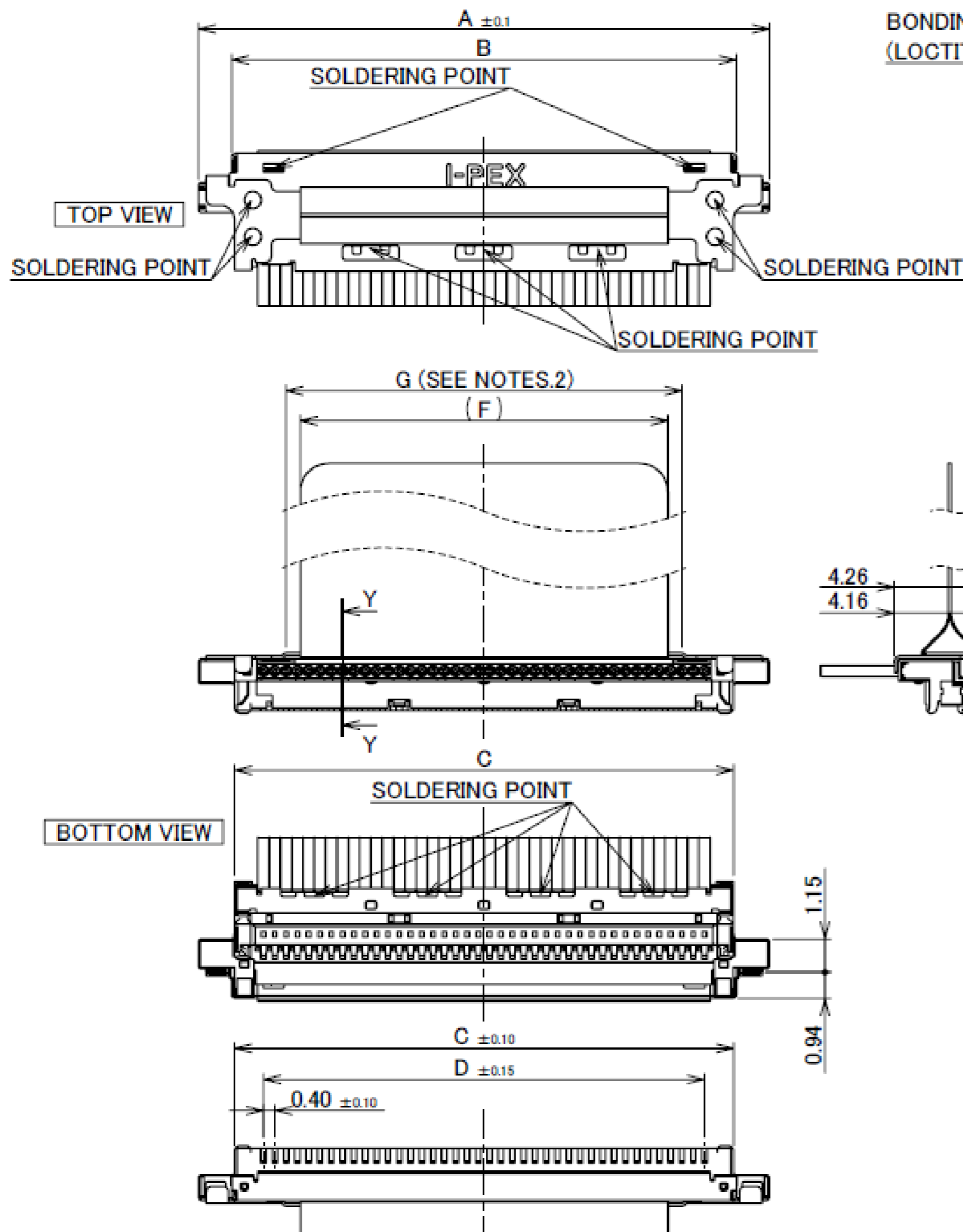

NO.	DISCRIPTION	MATERIAL	FINISH , REMARKS
5	PULL TAPE HOLDER	PHOSPHOR BRONZE	PARTIAL Au 0.003 μm MIN. OVER Ni 1.0 μm MIN.
4	SHELL B	PHOSPHOR BRONZE	PARTIAL Au 0.003 μm MIN. OVER Ni 1.0 μm MIN.
3	SHELL A	PHOSPHOR BRONZE	PARTIAL Au 0.003 μm MIN. OVER Ni 1.0 μm MIN.
2	CONTACT	CORSON ALLOY	ALL OVER Ni 1.0 μm MIN. CONTACT & SOLDERING AREA : Au 0.03 μm MIN.
1	HOUSING	LCP	UL94V-0 ,BLACK

NOTES.
 2.RECOMMENDED PULL-TAPE
 PULL-TAPE : TERAOKA's INSULATION TAPE No.650S(#50) t=0.08
 3.PULL-TAPE CAN BE PUT WITHIN THE RANGE OF "G" STRIAIGHT AREA.

Rev.14

PART NO.	Pos.	D
20877-030T-0#	30	11.60
20877-040T-0#	40	15.60
20877-050T-0#	50	19.60
20877-060T-0#	60	23.60

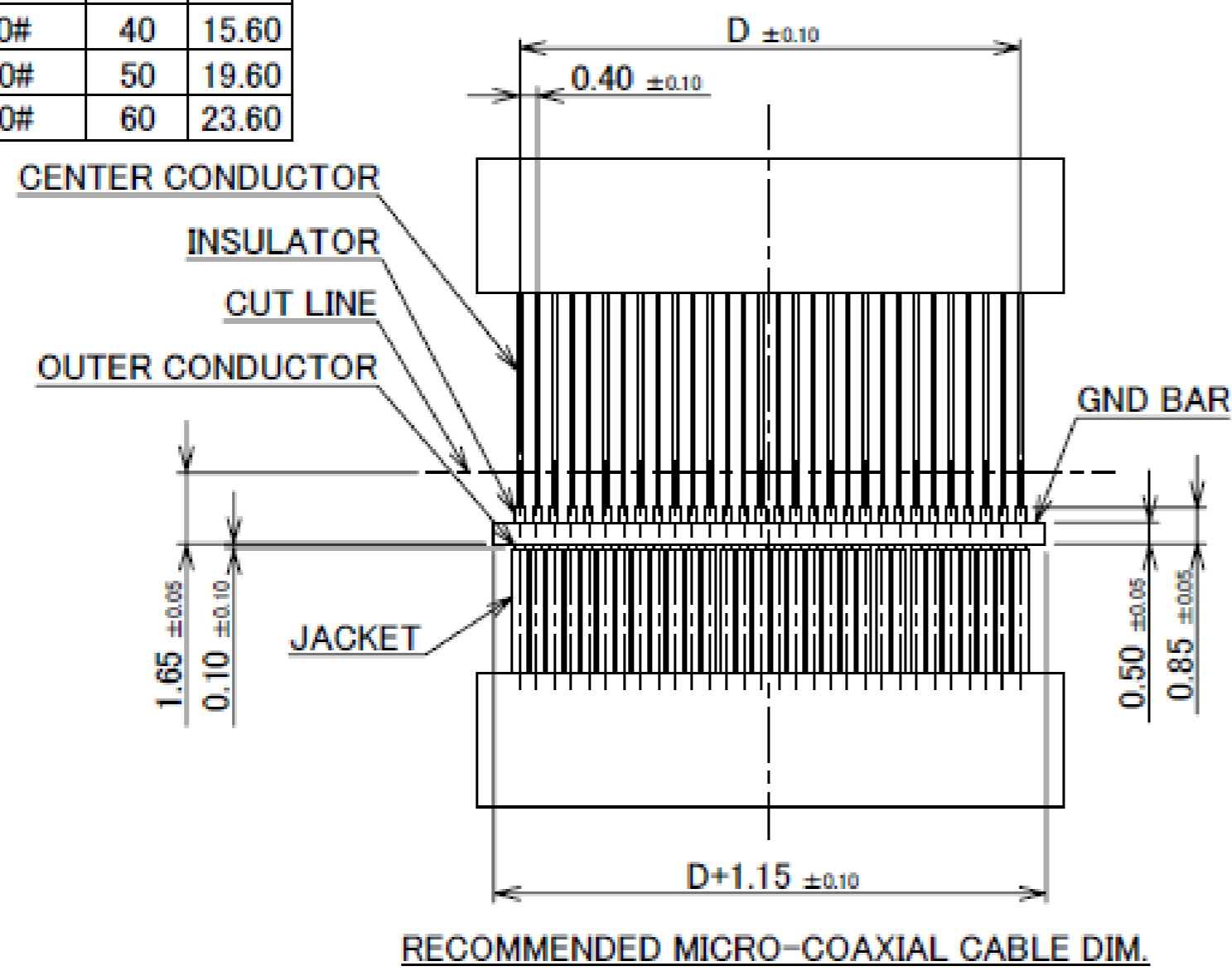

CHARACTERISTIC IMPEDANCE MATCHING MICRO-COAXIAL CABLE

	a
#38	0.12
#40	0.09
#42	0.075
#44	0.063

CHARACTERISTIC IMPEDANCE UN-MATCHING MICRO-COAXIAL CABLE

	a
#36	0.15

MICRO-COAXIAL CABLE #36 : NOT RECOMMENDED FOR HIGH SPEED SIGNAL TRANSFER

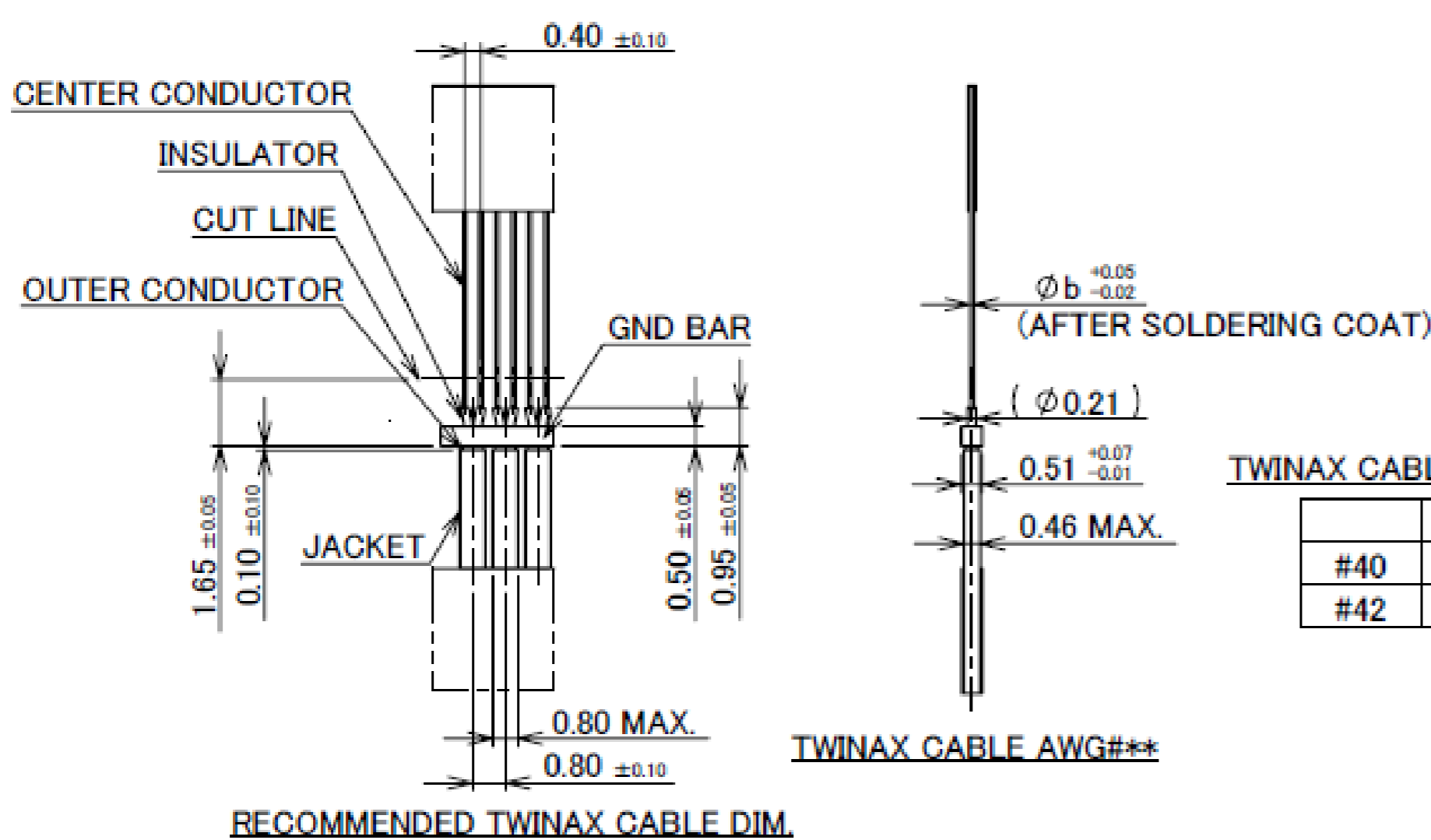
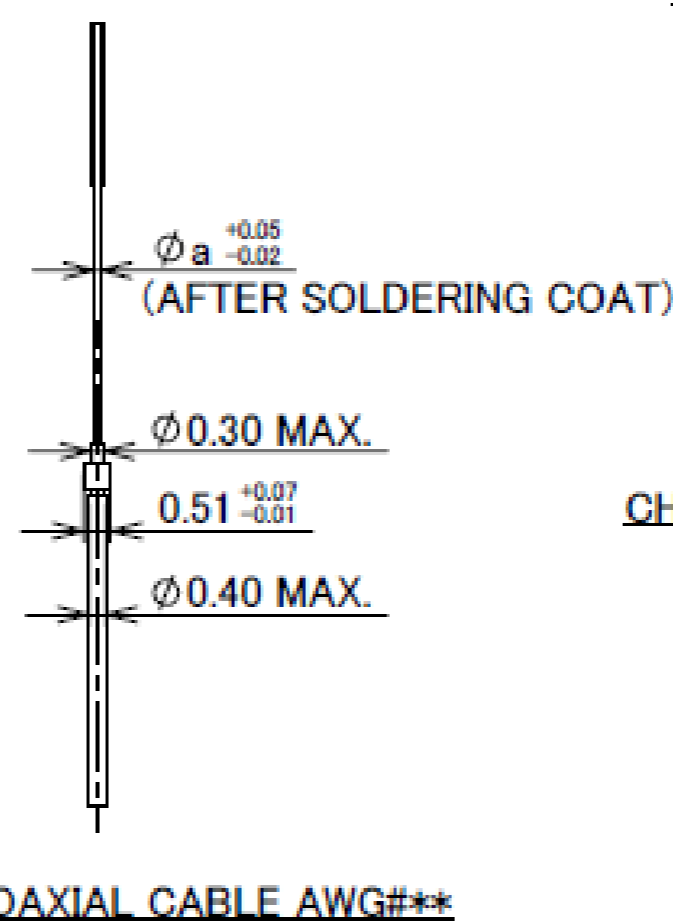

TWINAX CABLE DIMENSION

	b
#40	0.09
#42	0.075

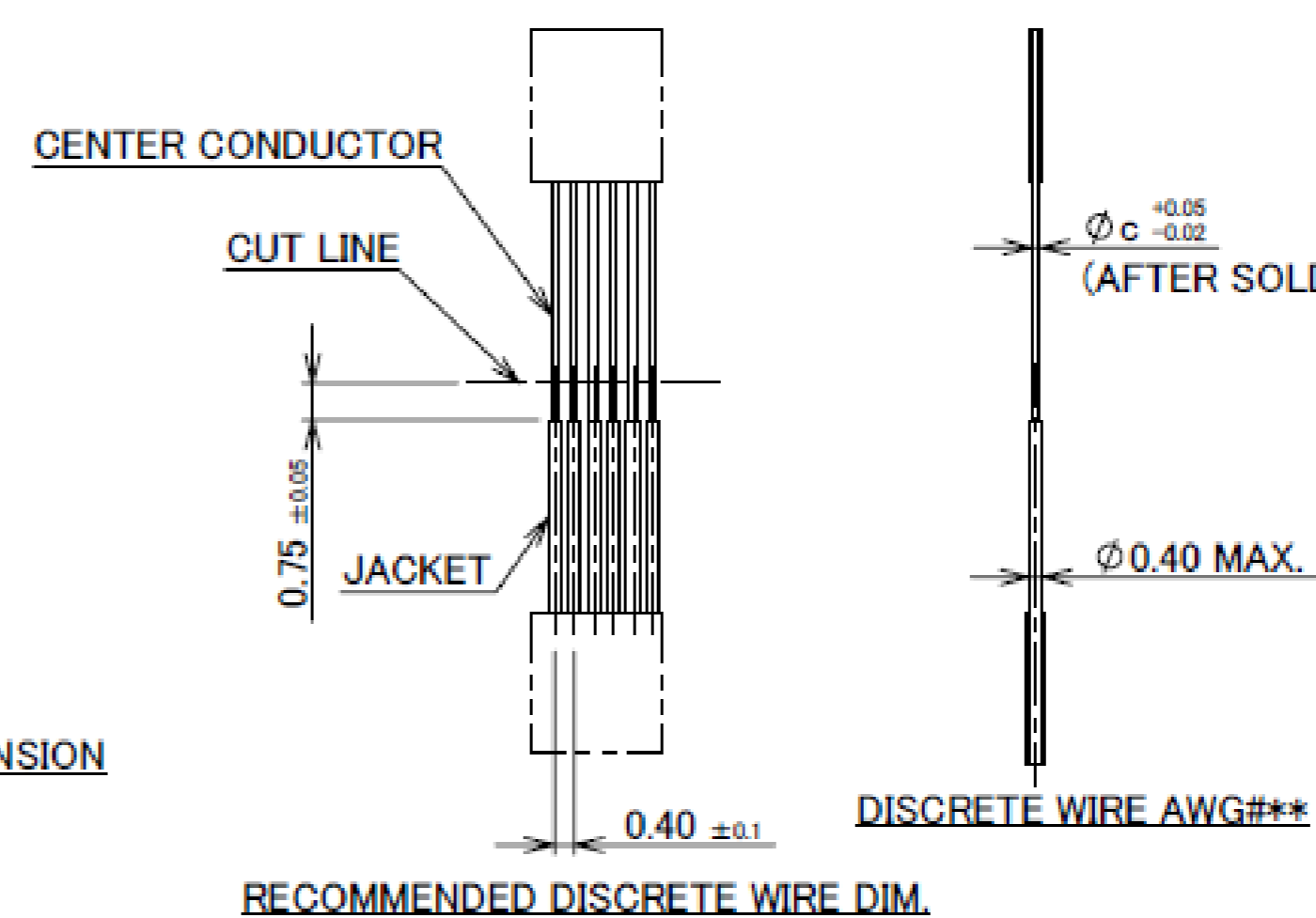

DISCRETE WIRE DIMENSION

	c
#34	0.192
#36	0.15

Rev.14

Plug Housing Assembly

Recommended P/N 20878-0**T-01

PART No.	Pos.	A	B	C	D	E	F	G	H
20878-030T-01	30	13.65	11.60	16.20	12.01	8.00	13.00	12.65	4.0
20878-040T-01	40	17.65	15.60	20.20	16.01	12.00	17.00	16.65	8.0
20878-060T-01	60	25.65	23.60	28.20	24.01	20.00	25.00	24.65	16.00

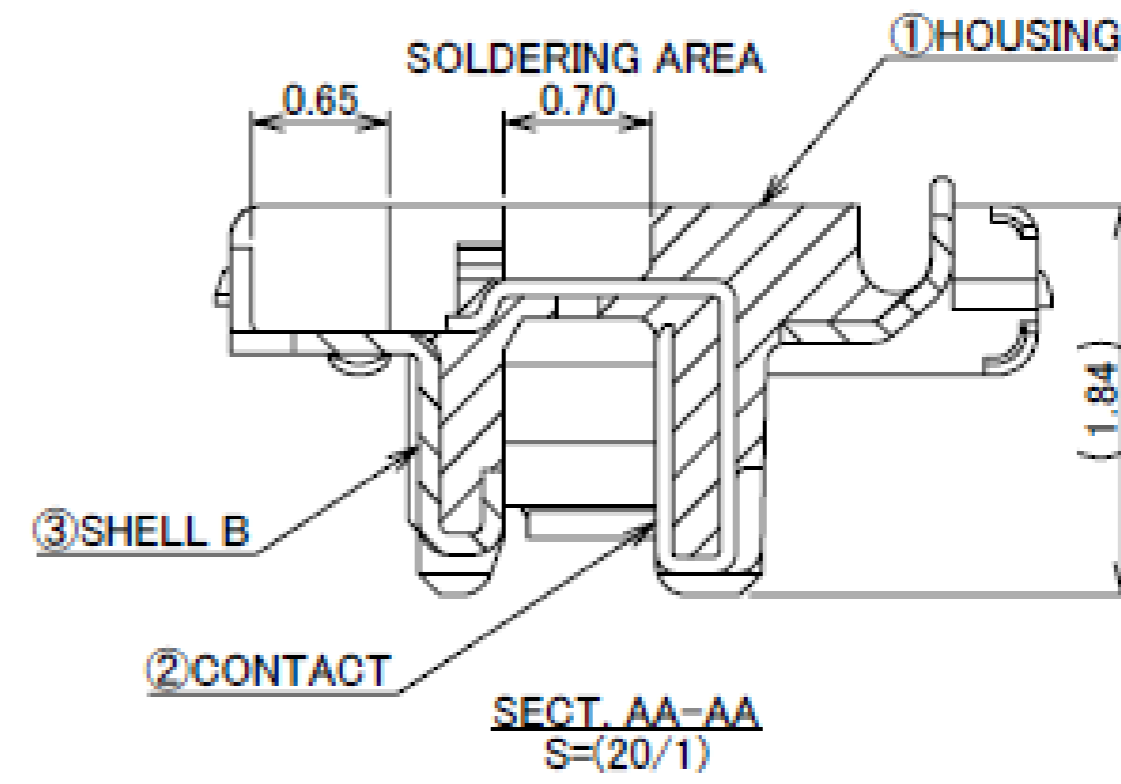
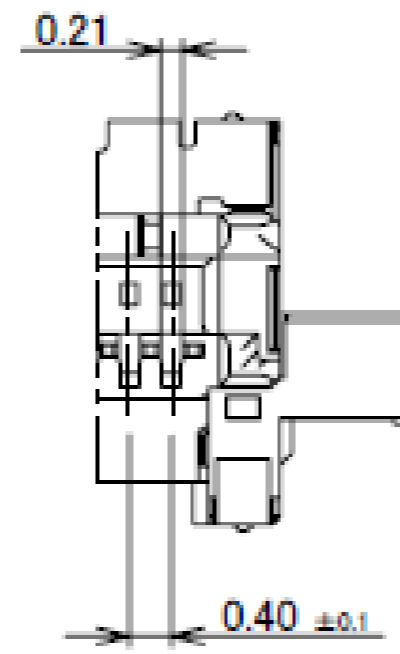
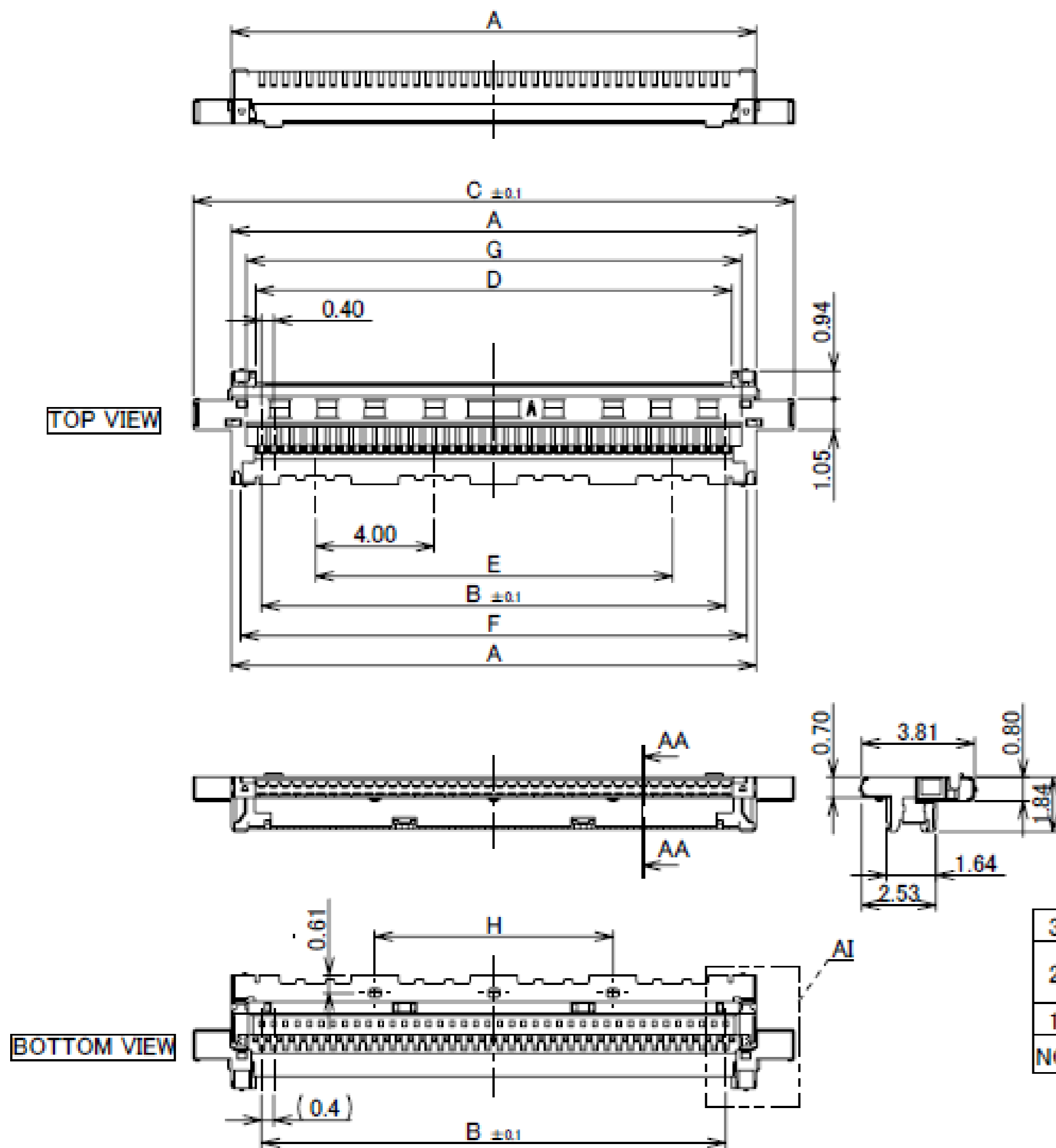
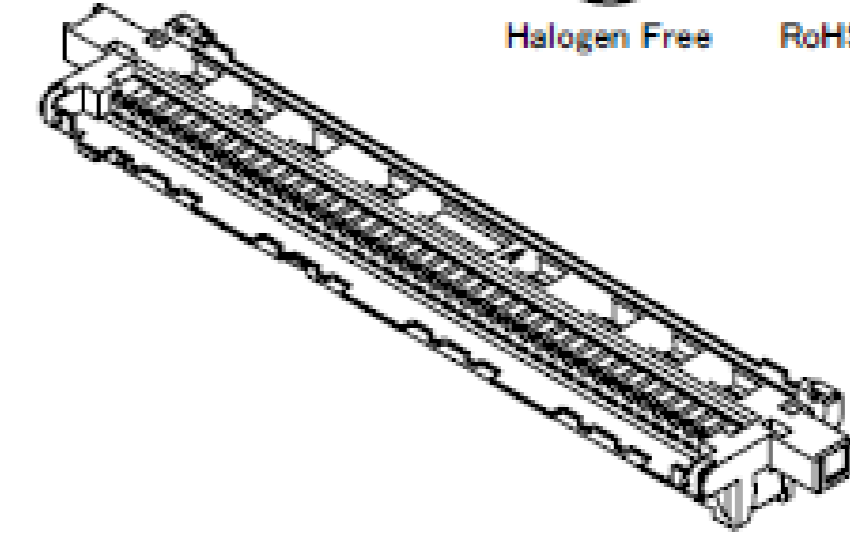

NO.	DISCRIPTION	MATERIAL	FINISH , REMARKS
3	SHELL B	PHOSPHOR BRONZE	PARTIAL Au 0.003 μ m MIN. OVER Ni 1.00 μ m MIN.
2	CONTACT	CORSON ALLOY	ALL OVER Ni 1.00 μ m MIN. CONTACT & SOLDERING AREA : Au 0.03 μ m MIN.
1	HOUSING	LCP	UL94V-0 .BLACK

Rev.4

Plug Shell-A

Recommended P/N 3488-0**1

PART No.	Pos.	A	B	C	D	E
3488-0301	30	16.20	13.88	4.00	13.65	9.36
3488-0401	40	20.20	17.88	8.00	17.65	13.36
3488-0501	50	24.20	21.88	12.00	21.65	17.36
3488-0601	60	28.20	25.88	16.00	25.65	21.36

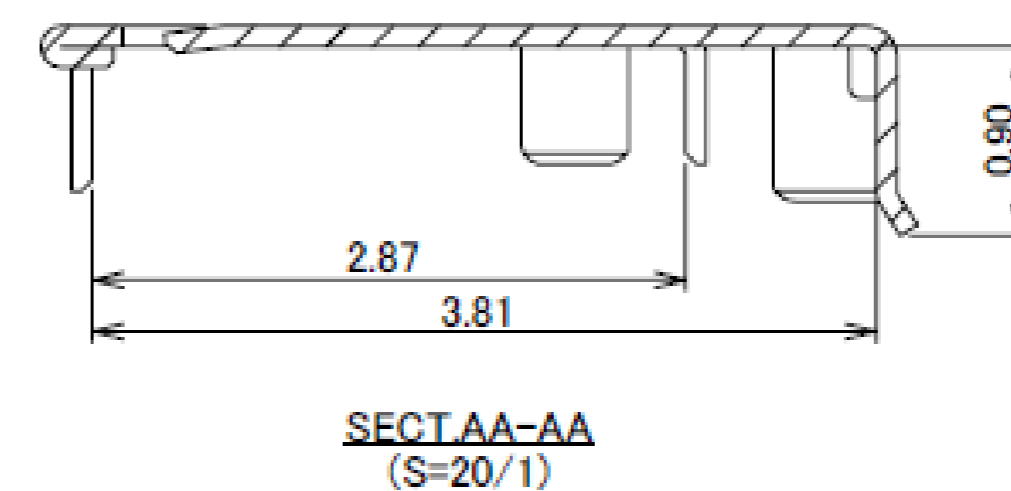
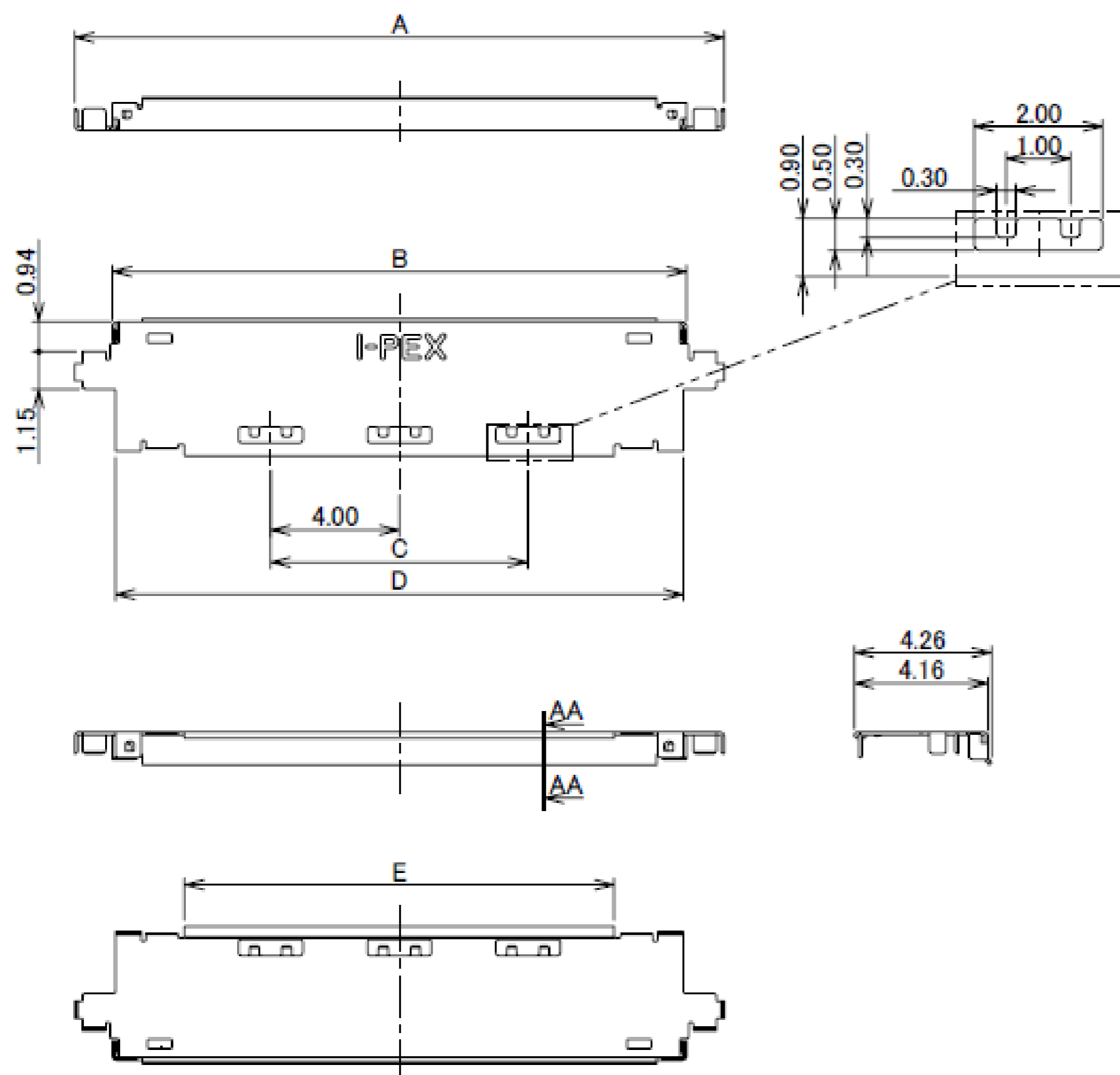
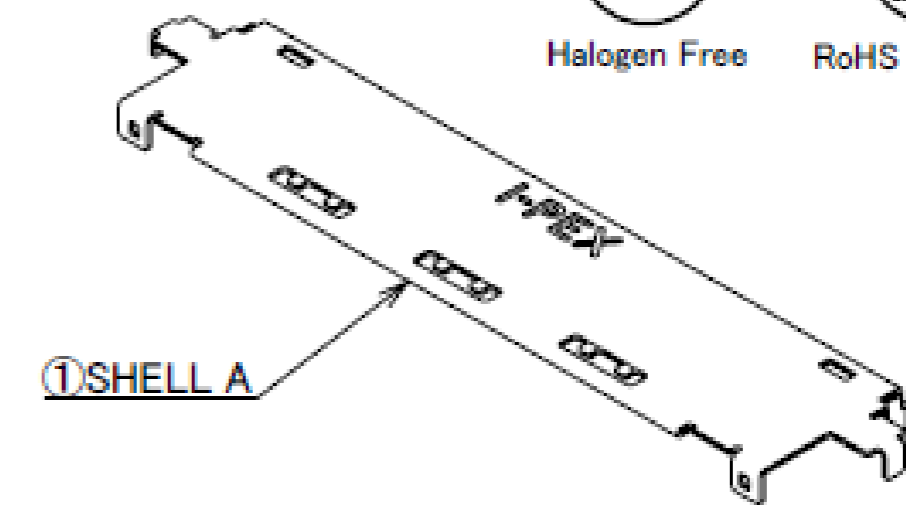

NO.	DISCRIPTION	MATERIAL	FINISH , REMARKS
1	SHELL A	PHOSPHOR BRONZE	PARTIAL Au 0.003 μ m MIN. OVER Ni 1.00 μ m MIN.

Rev.4

Plug Pull Tape Holder

Recommended P/N		3588-0**1		
PART NO.	Pos.	A	B	C
3588-0301	30	10.00	15.65	13.65
3588-0401	40	14.00	19.65	17.65
3588-0501	50	18.00	23.65	21.65
3588-0601	60	22.00	27.65	25.65

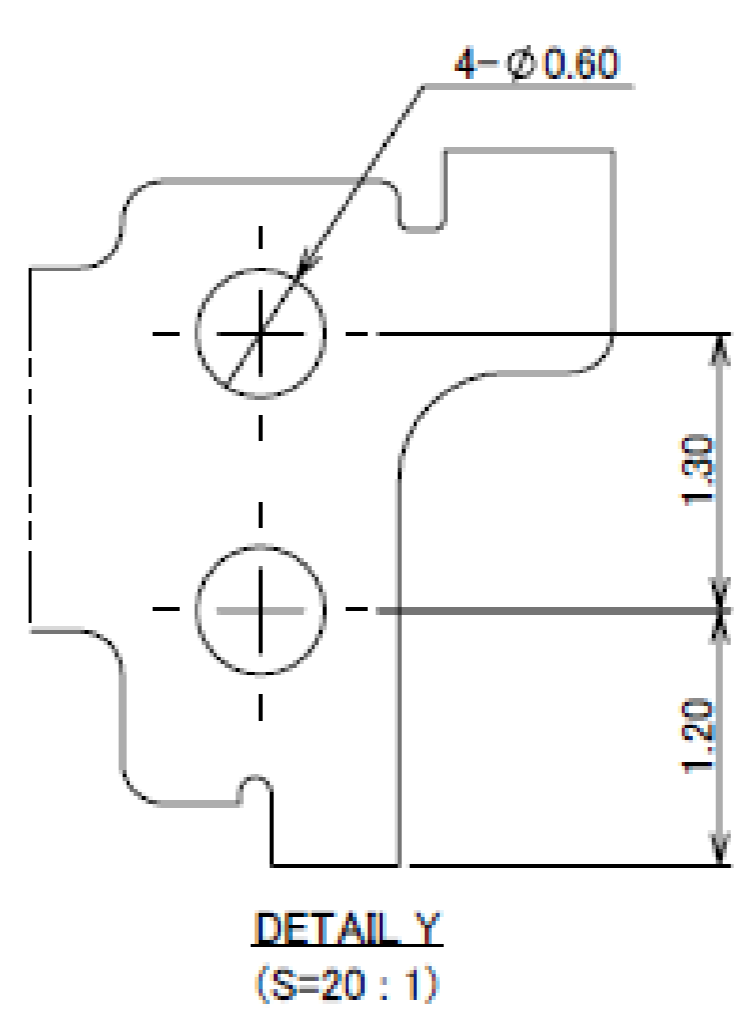
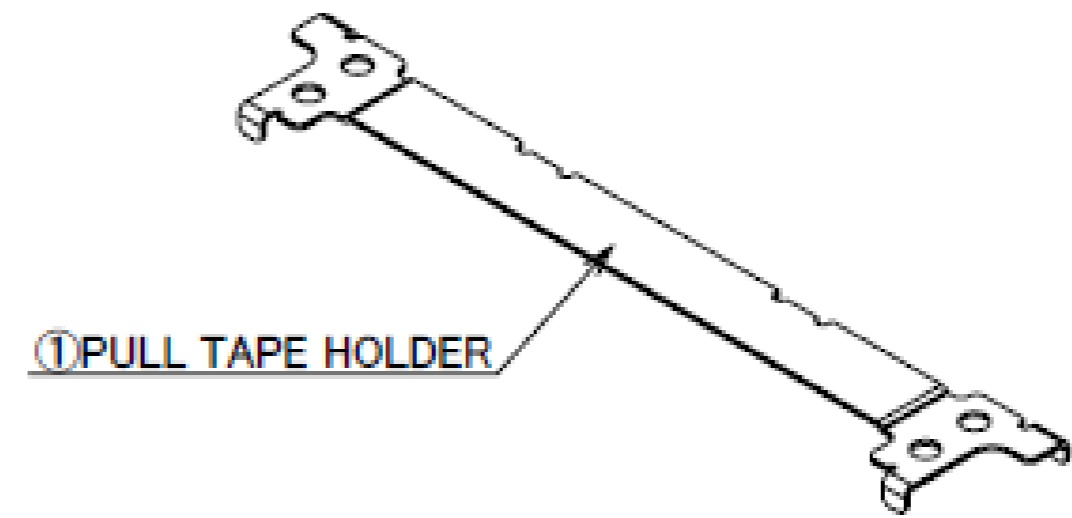
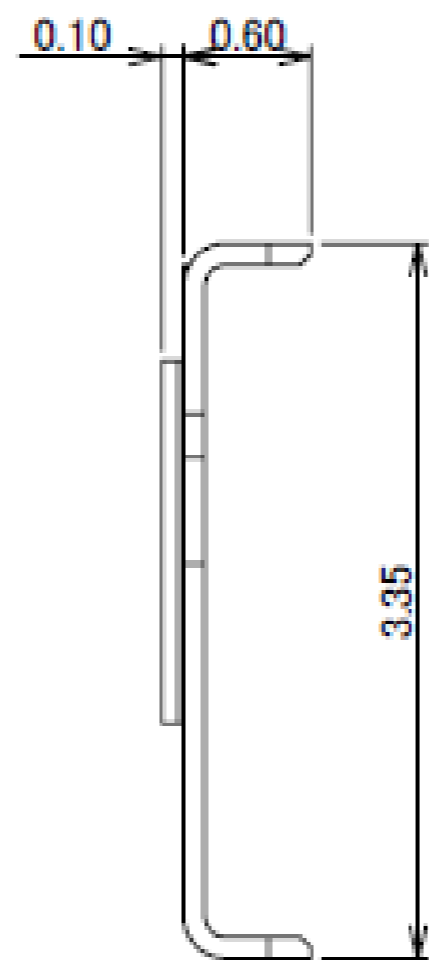
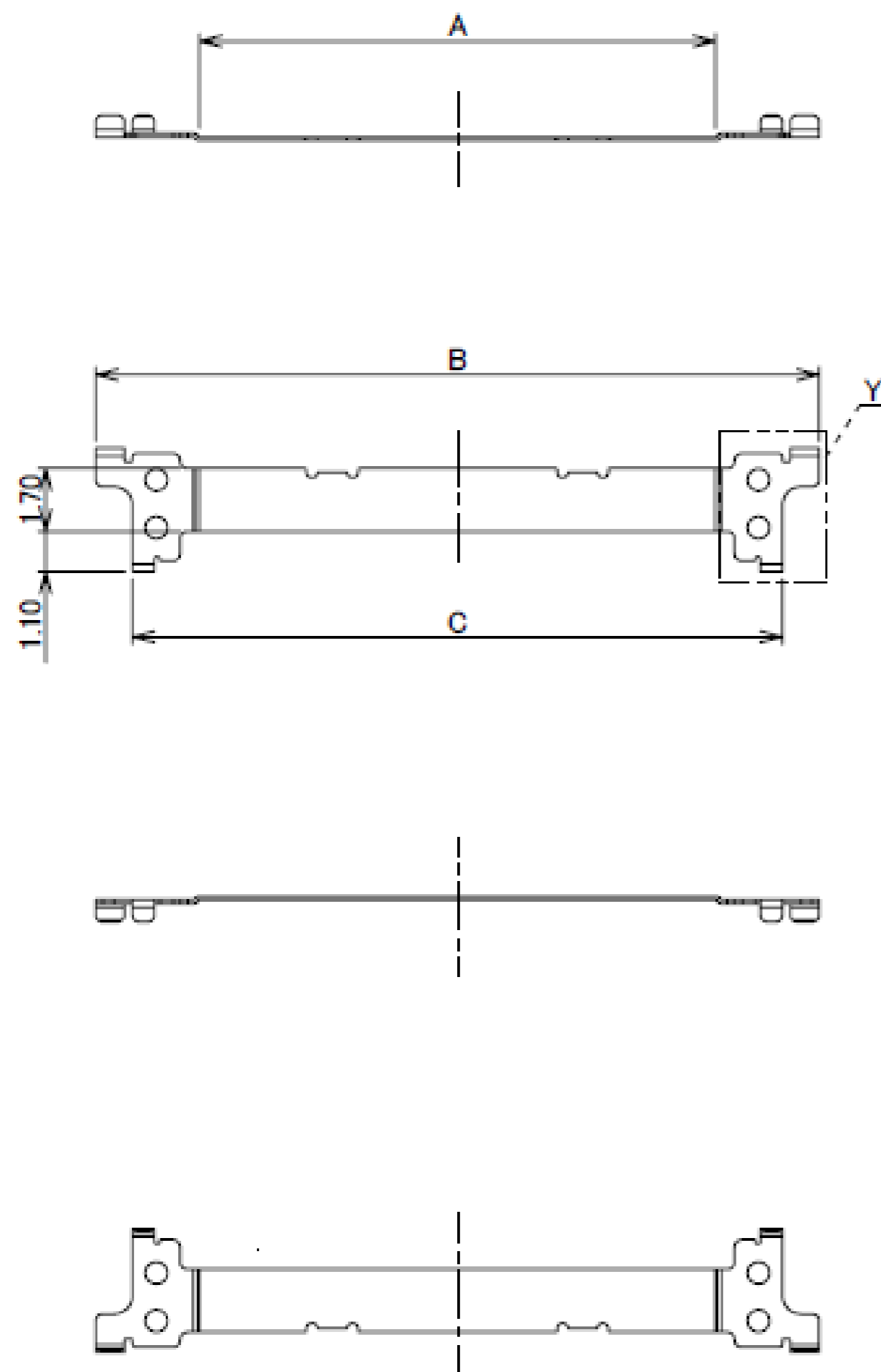

NO.	DISCRIPTION	MATERIAL	FINISH , REMARKS
1	PULL TAPE HOLDER	PHOSPHOR BRONZE	PARTIAL Au 0.003 μm MIN. OVER Ni 1.00 μm MIN.

Rev.4

Lock Cover

Recommended P/N		3493-0**1			
PART NO.	Pos.	A	B	C	D
3493-0301	30	17.00	14.05	12.40	15.30
3493-0401	40	21.00	18.05	16.40	19.30
3493-0601	60	29.00	26.05	24.40	27.30

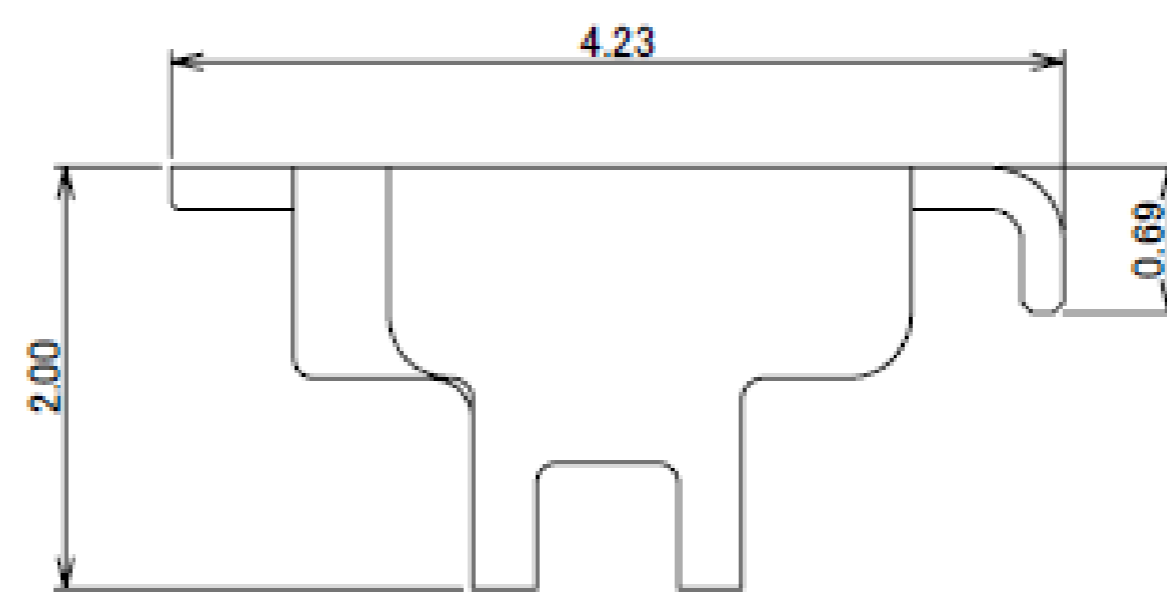
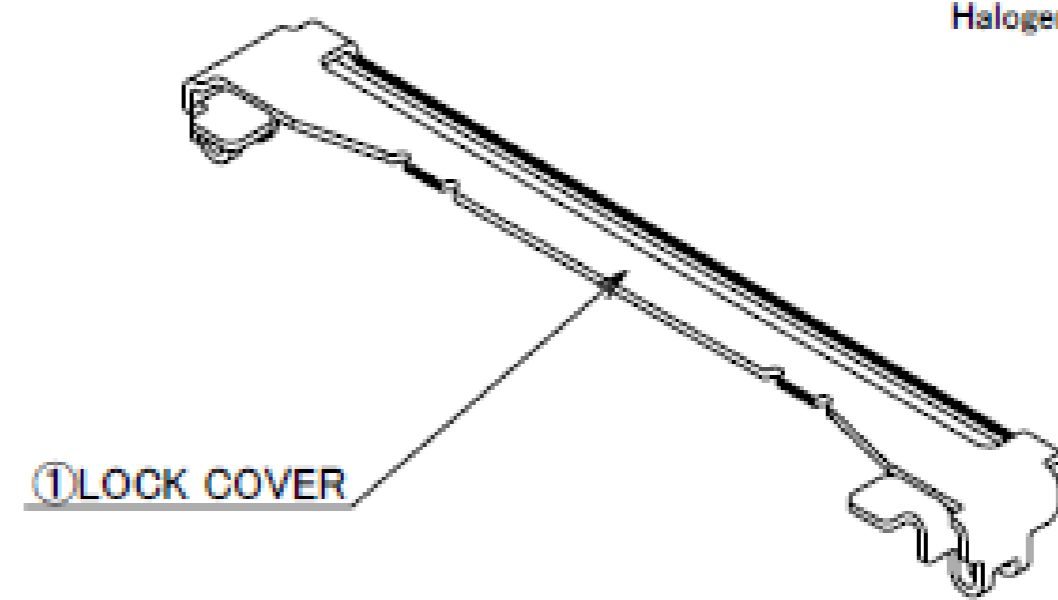
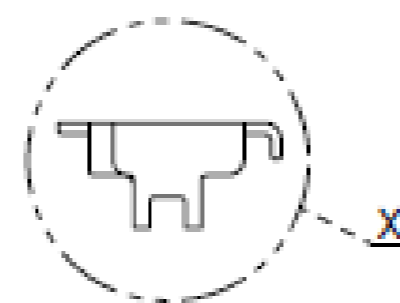
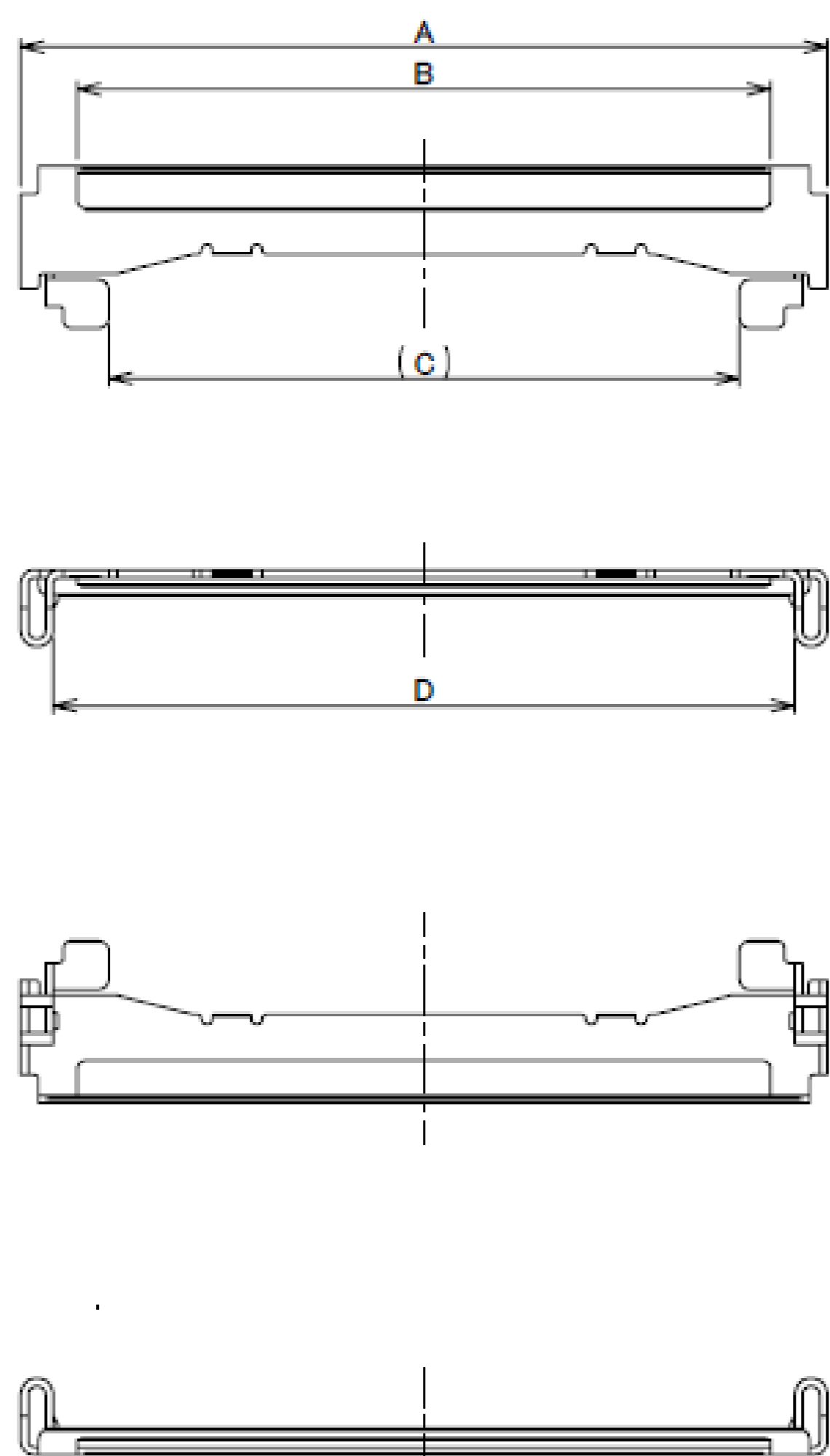

NO.	DISCRIPTION	MATERIAL	FINISH , REMARKS
1	LOCK COVER	PHOSPHOR BRONZE	ALL OVER Ni 1.00 μm MIN.

Rev.3

Receptacle Assembly

Recommended P/N		20879-0**E-01							
PART NO.	Pos.	A	B	C	D	E	F	G	H
20879-030E-#1	30	15.27	13.01	11.60	9.60	12.07	12.88	15.27	13.65
20879-040E-#1	40	19.27	17.01	15.60	14.40	16.07	16.88	19.27	17.65
20879-050E-11	50	23.27	21.01	19.60	17.60	20.07	20.88	23.27	21.65
20879-060E-#1	60	27.27	25.01	23.60	21.60	24.07	24.88	27.27	25.65

P/N : 20879-0**E-##
 1 : NARROW GROUND PIN TYPE
 2 : WIDER GROUND PIN TYPE
 SEE TABLE.1
 Pos.

#1 TYPE

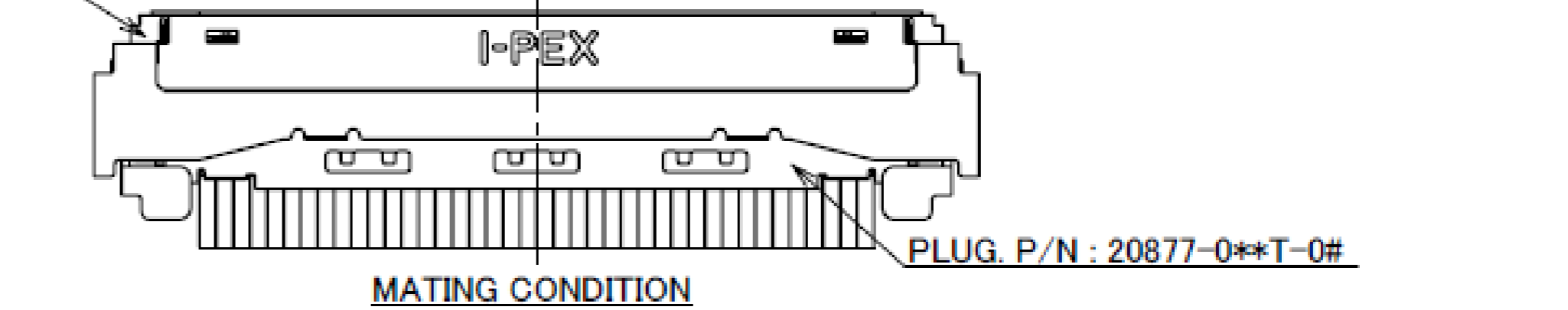
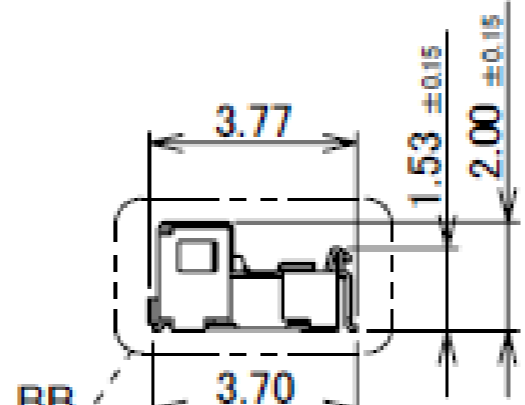
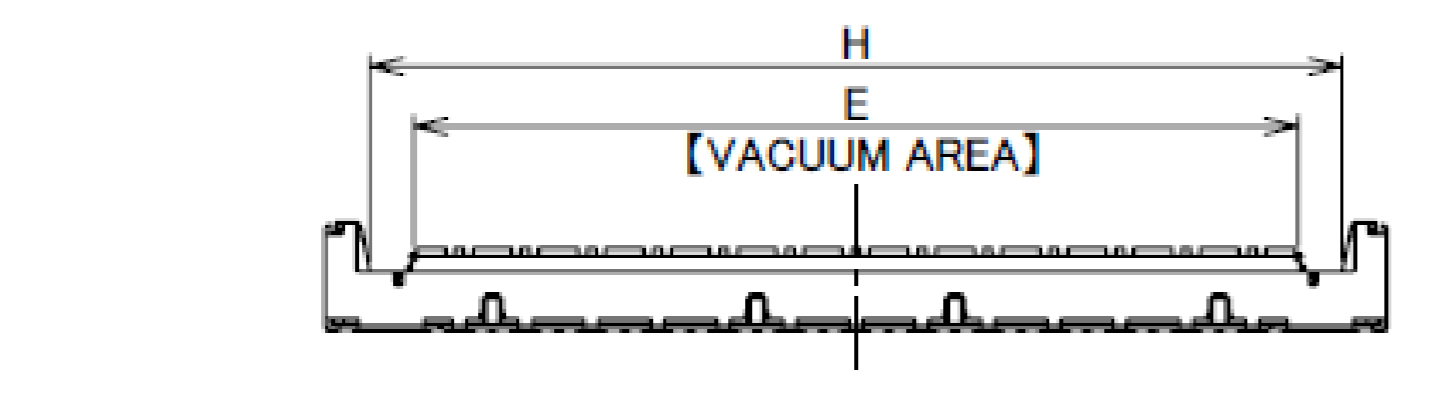
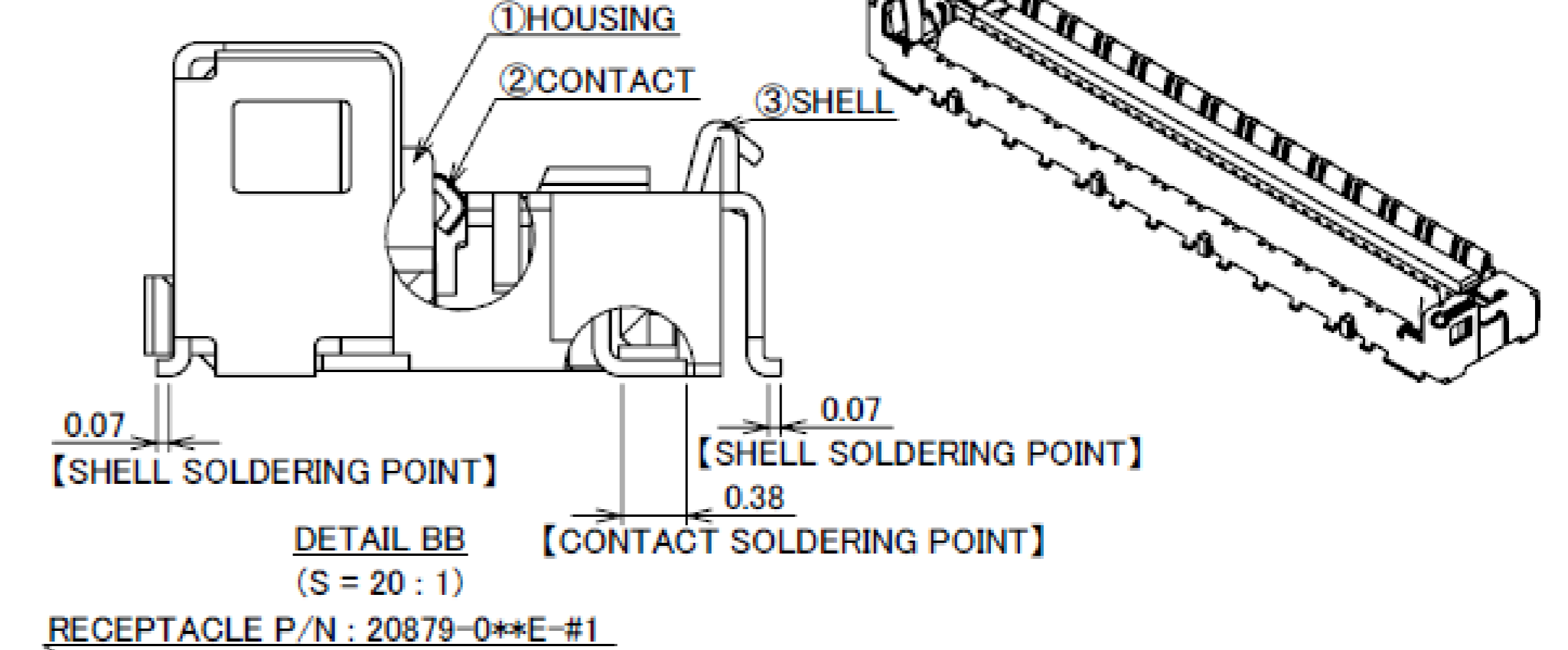
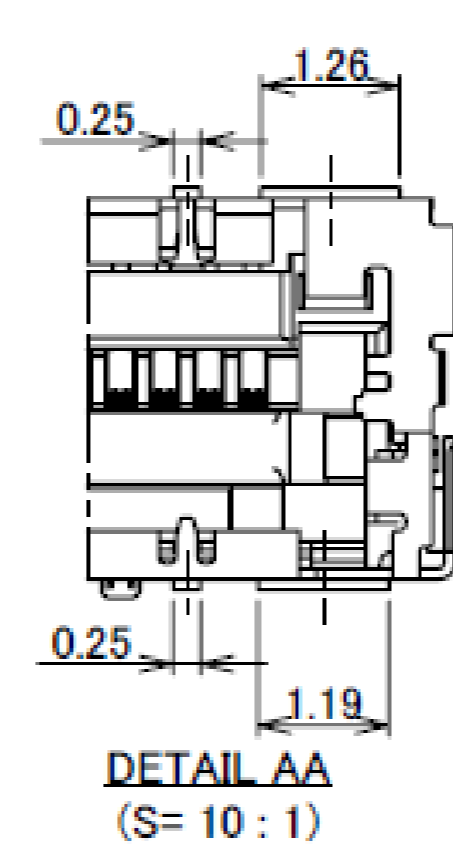
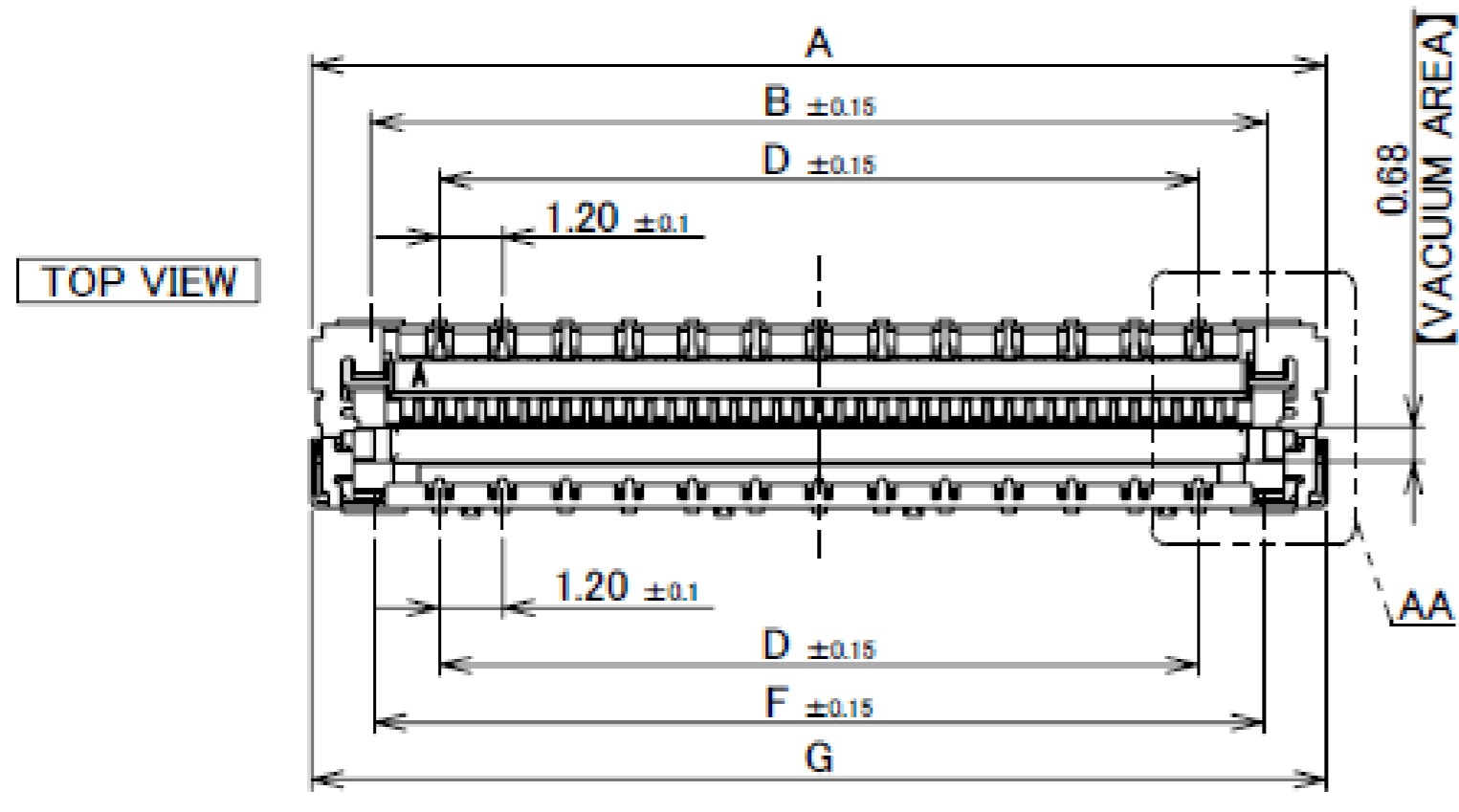

PART NO.	CONTACT FINISH
20879-0**E-01	ALL OVER Ni 1.00 μm MIN. CONTACT & SOLDERING AREA : Au 0.03 μm MIN.
20879-0**E-11	ALL OVER Ni 1.27 μm MIN. CONTACT AREA : Au 0.254 μm MIN. SOLDERING AREA : Au 0.03 μm MIN.

NO.	DISCRIPTION	MATERIAL	FINISH , REMARKS
3	SHELL	PHOSPHOR BRONZE	ALL OVER : Ni 1.00 μm MIN. SOLDERING AREA : Au 0.02 μm MIN.
2	CONTACT	CORSON ALLOY	SEE TABLE.1
1	HOUSING	LCP	UL94V-0, BLACK

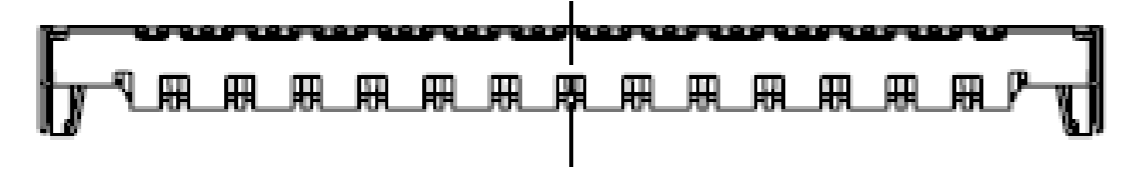
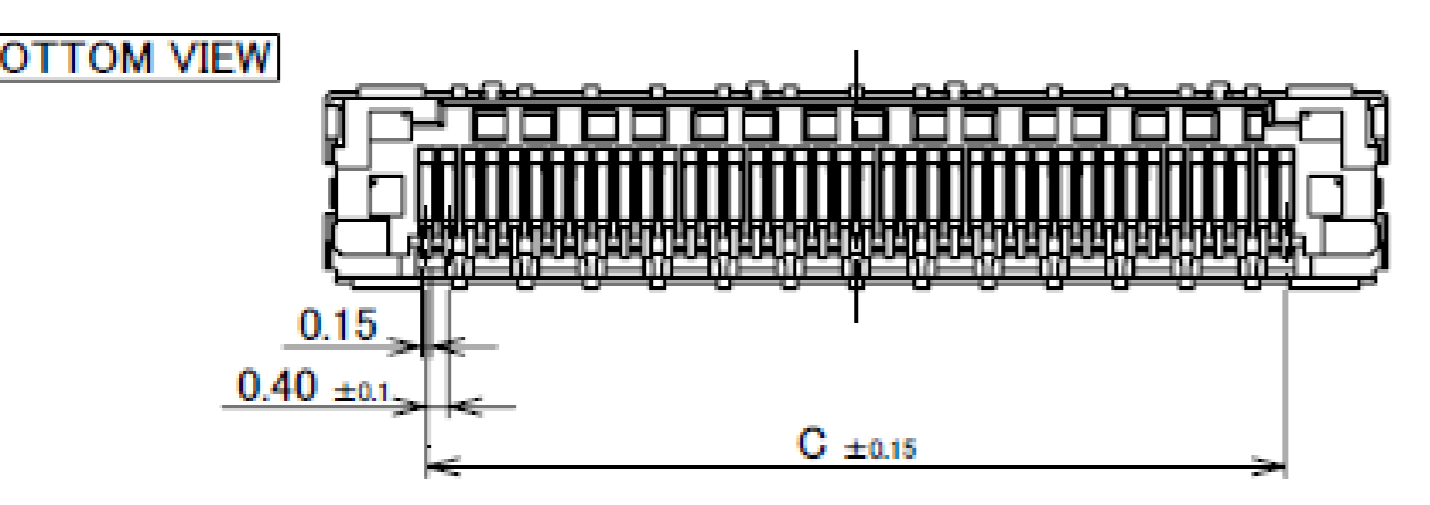

Rev.13

Recommended P/N		20879-0**E-01		
PART NO.	Pos.	A	D	G
20879-030E-#1	30	15.27	9.60	15.27
20879-040E-#1	40	19.27	14.40	19.27
20879-050E-11	50	23.27	17.60	23.27
20879-060E-#1	60	27.27	21.60	27.27

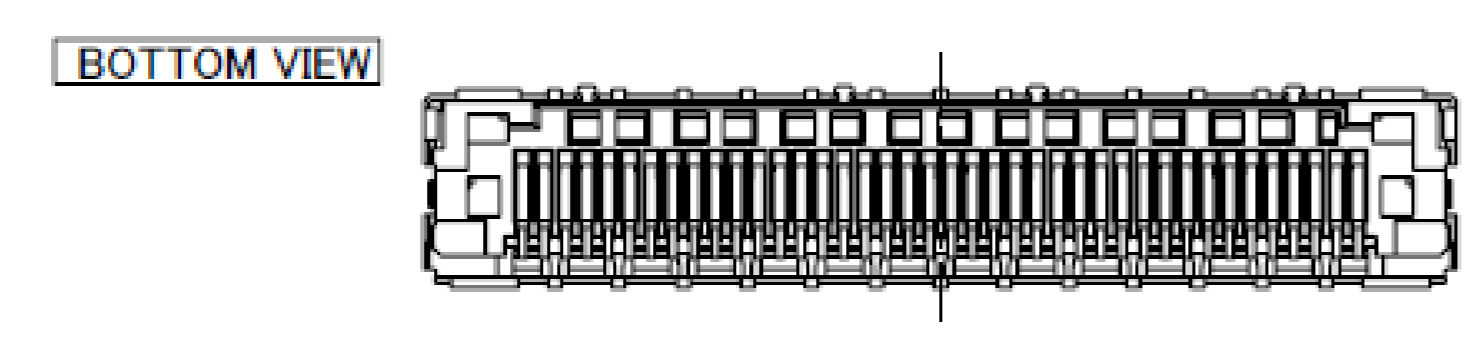
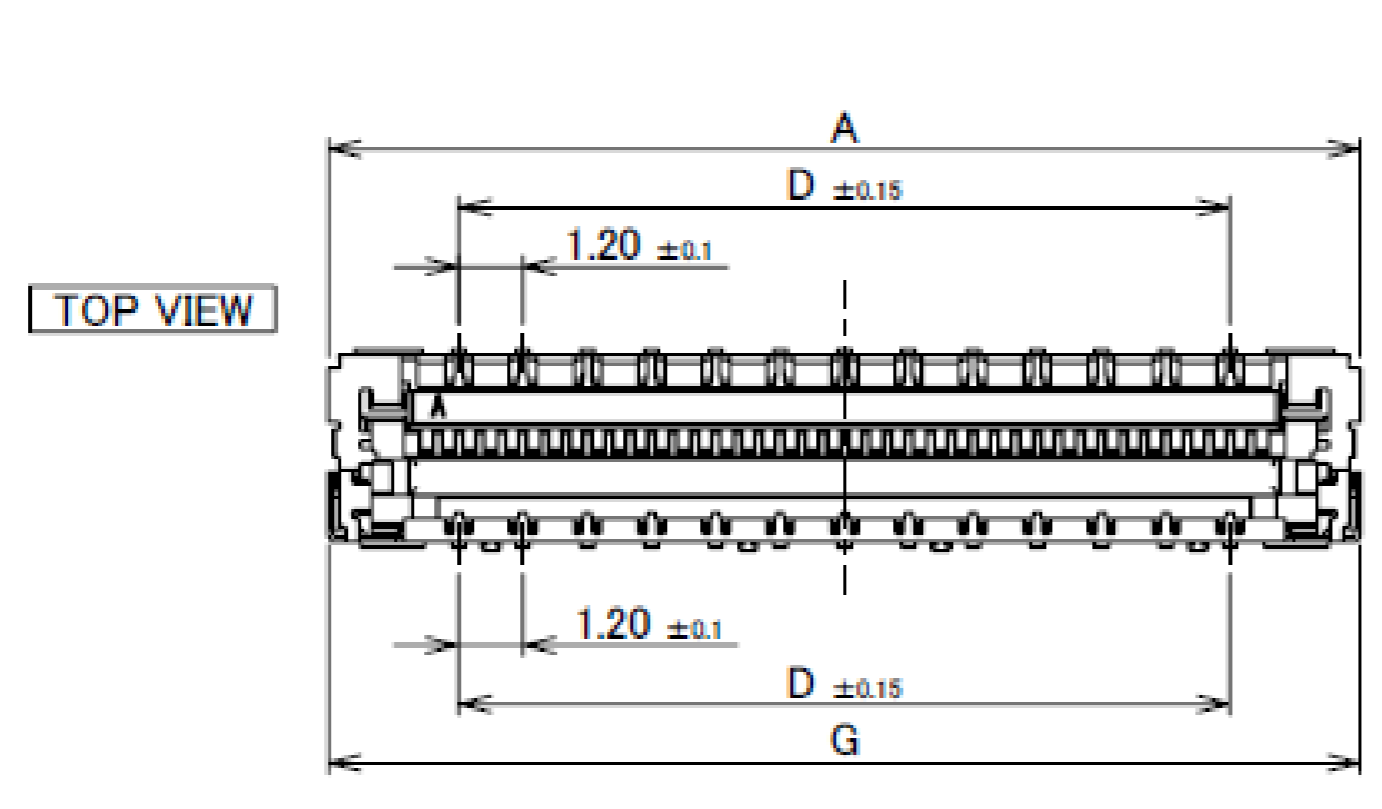

30P, 40P, 60P

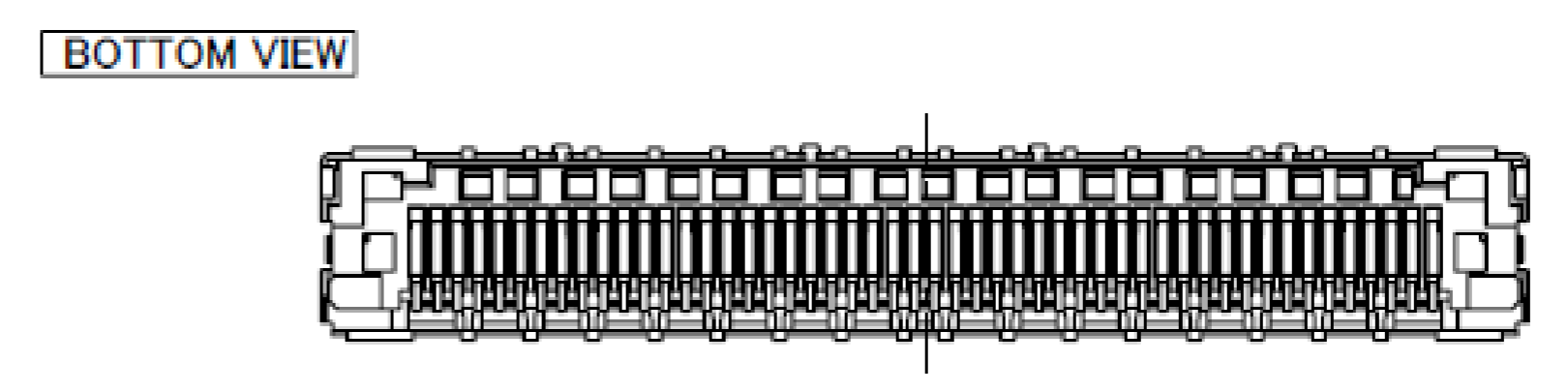
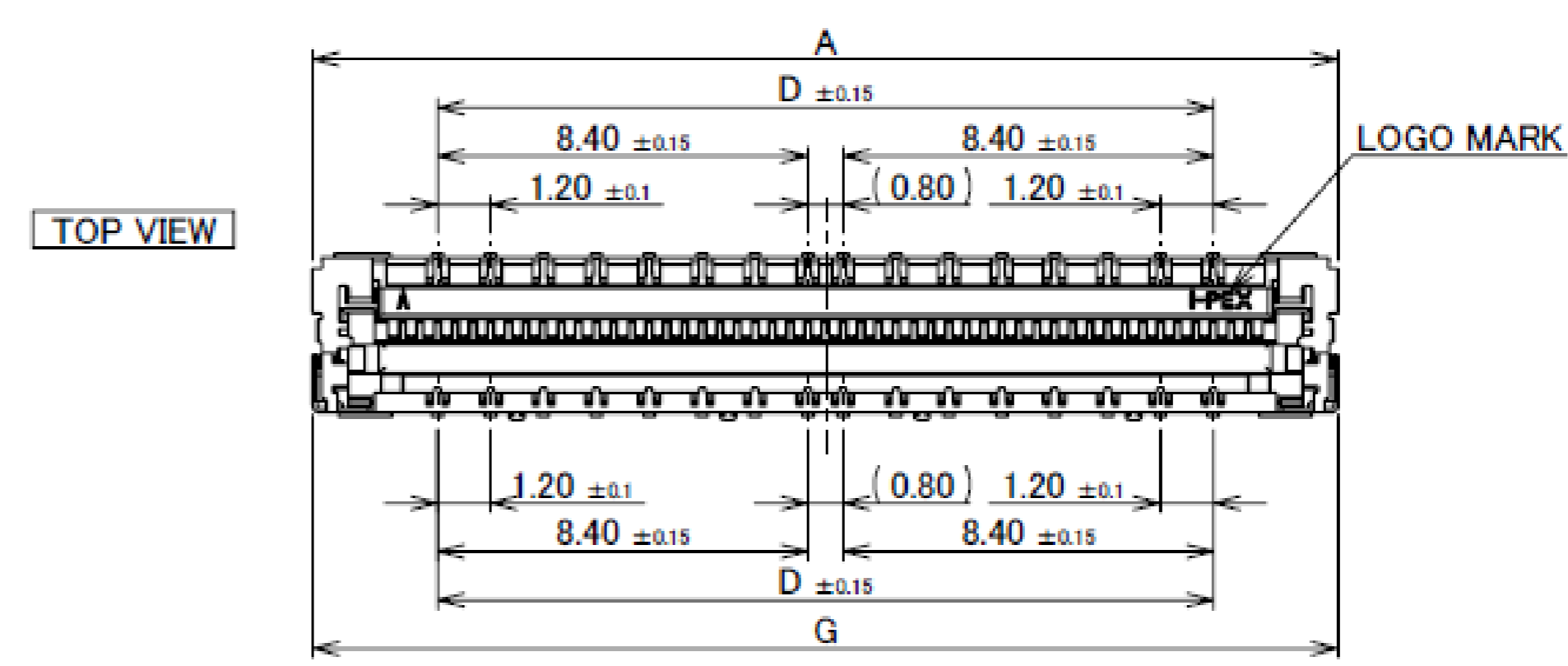

50P

Rev.13



Receptacle Assembly

Recommended P/N 20879-0**E-01

PART NO.	Pos.	A	C	E	G	H	J	K	L	M	N
20879-030E-02	30	15.27	11.60	12.07	15.27	13.65	14.87	4.00	-	7.09	14.69
20879-040E-02	40	19.27	15.60	16.07	19.27	17.65	18.87	8.00	4.00	6.70	18.69
20879-060E-02	60	27.27	23.60	24.07	27.27	25.65	26.87	17.60	11.20	10.70	26.69

02 TYPE

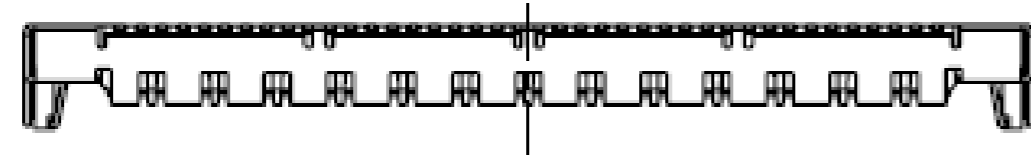
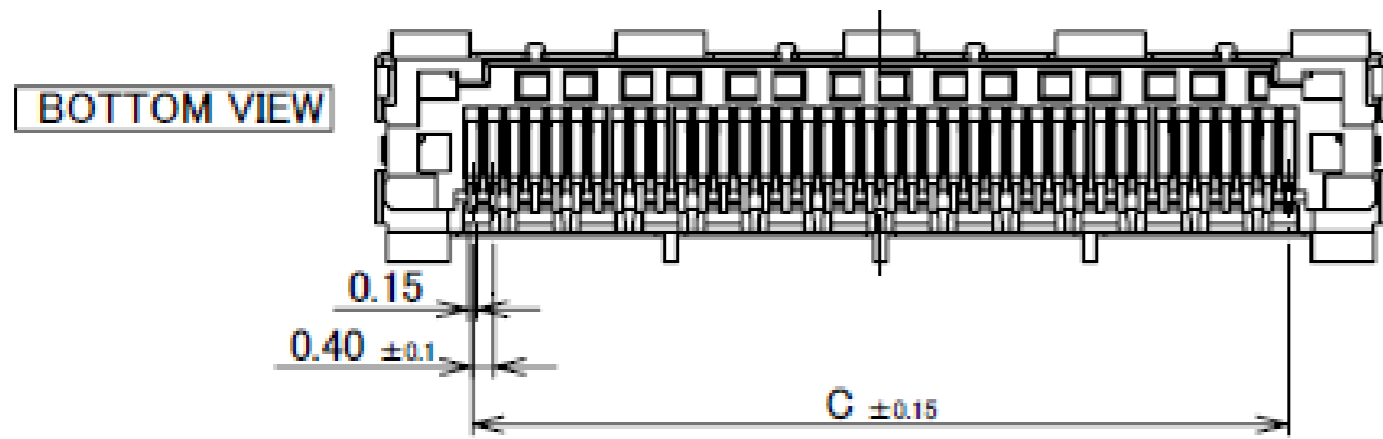
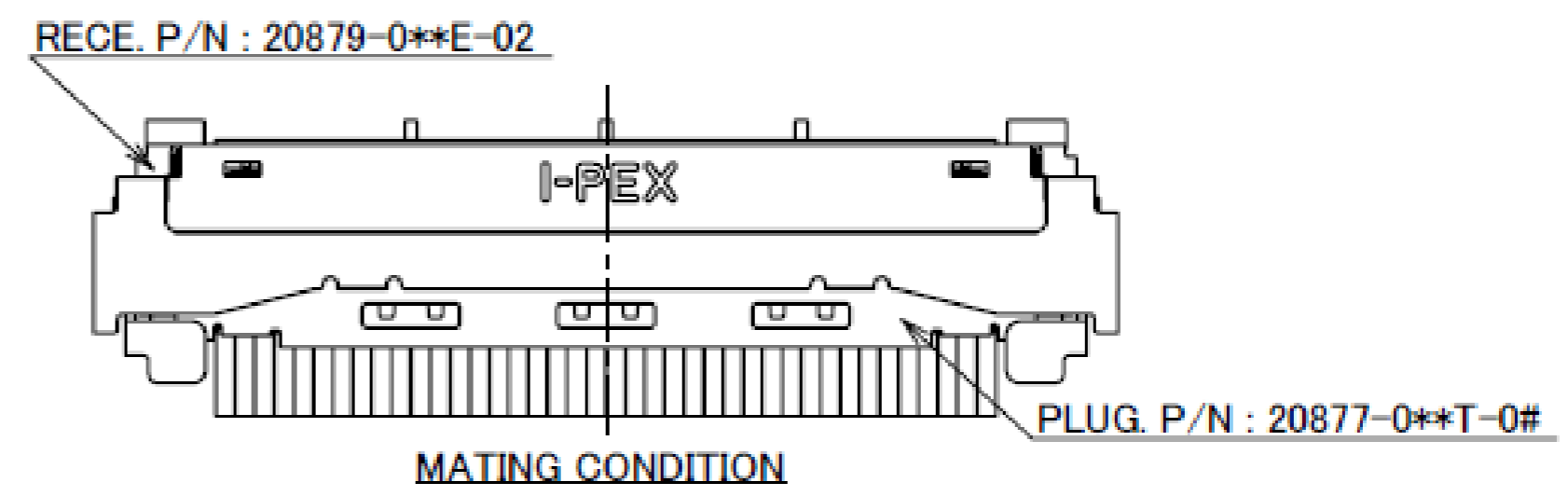
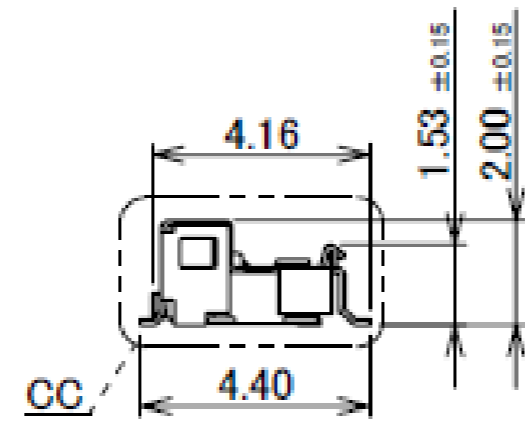
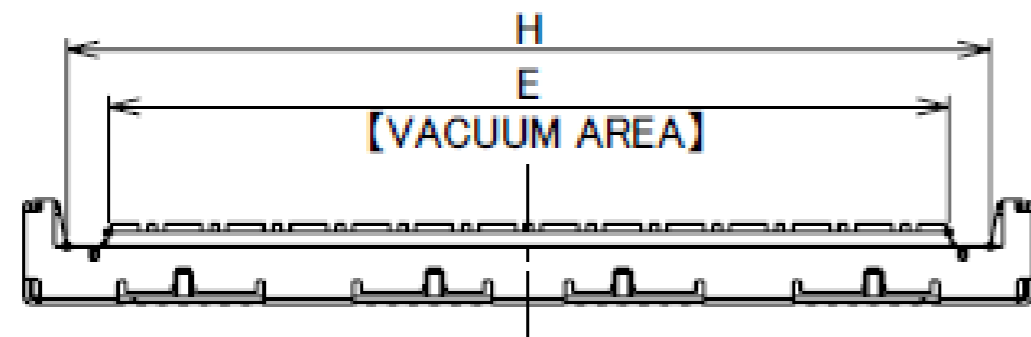
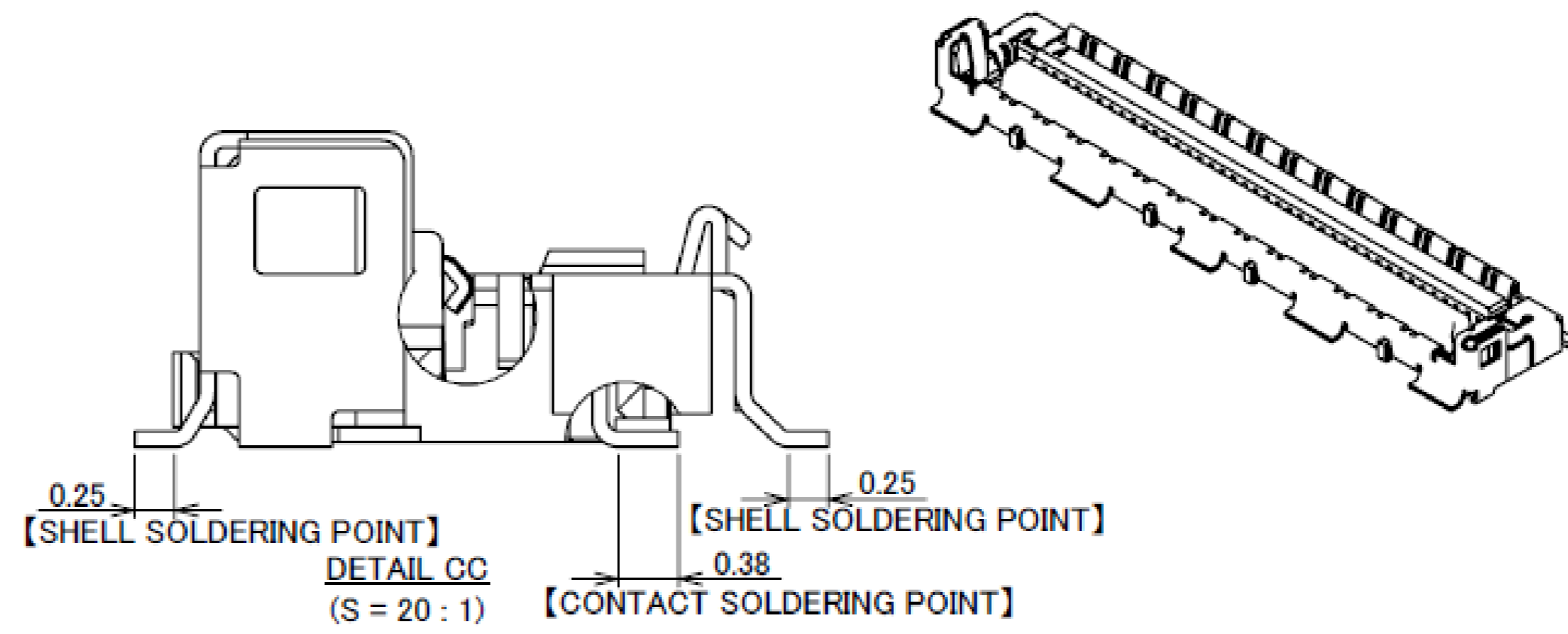
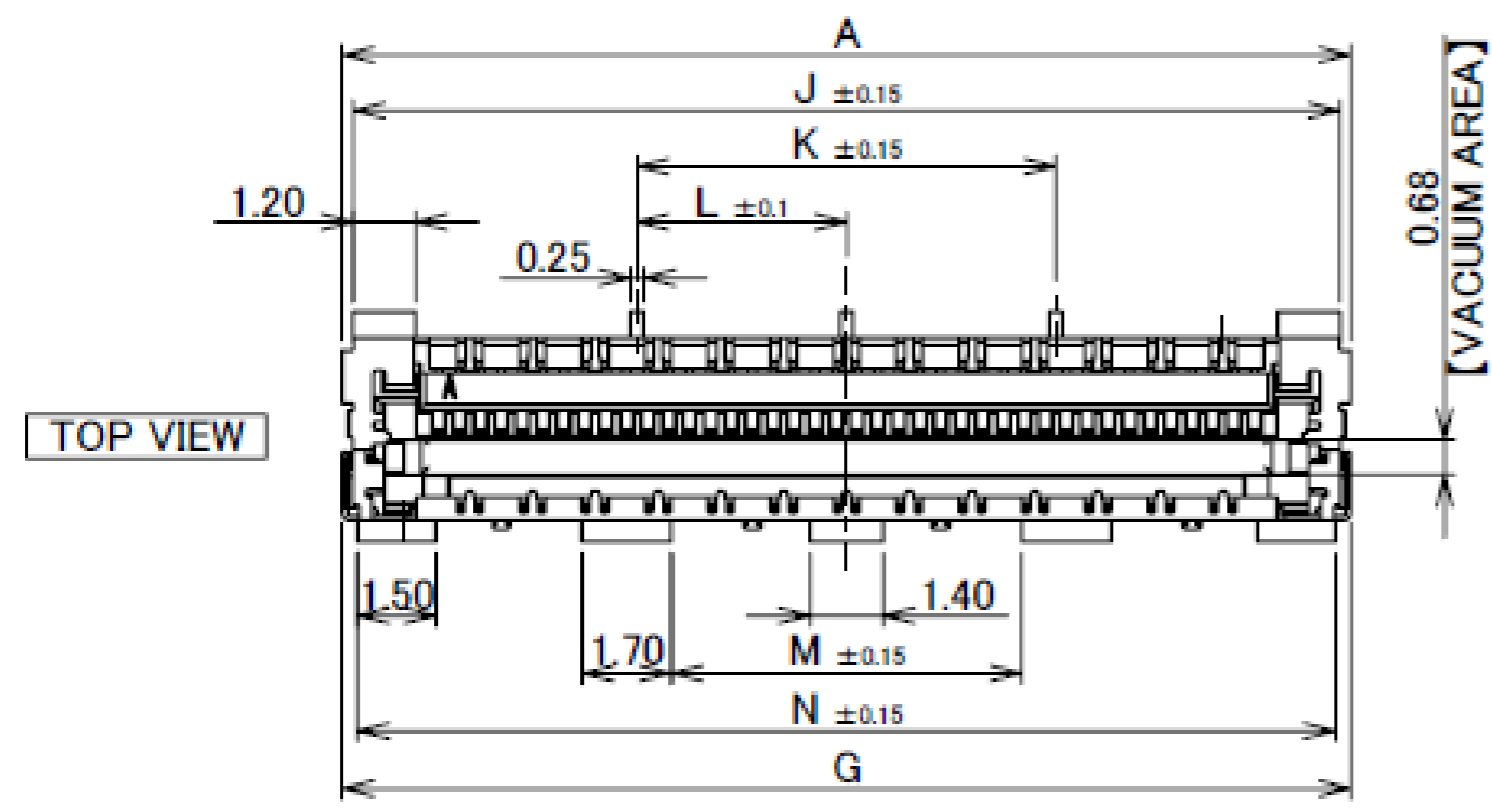

Rev.13

Recommended P/N 20879-0**E-01

PART NO.	Pos.	A	C	E	G	H	J	K	L	M	N	AD
20879-030E-02	30	15.27	11.60	12.07	15.27	13.65	14.87	4.00	-	7.09	14.69	-
20879-040E-02	40	19.27	15.60	16.07	19.27	17.65	18.87	8.00	4.00	6.70	18.69	-
20879-060E-02	60	27.27	23.60	24.07	27.27	25.65	26.87	17.60	11.20	10.70	26.69	3.20

02 TYPE

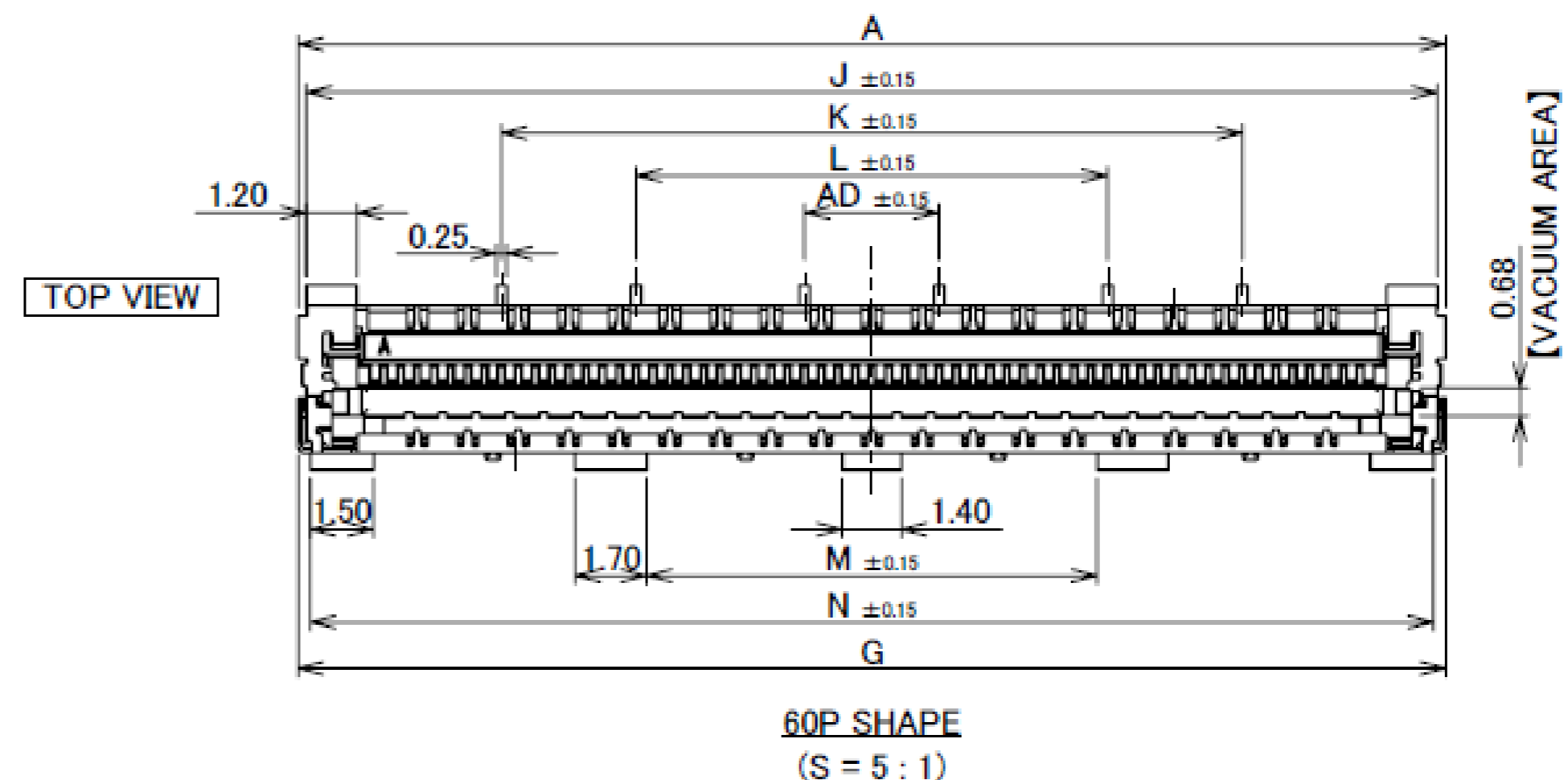
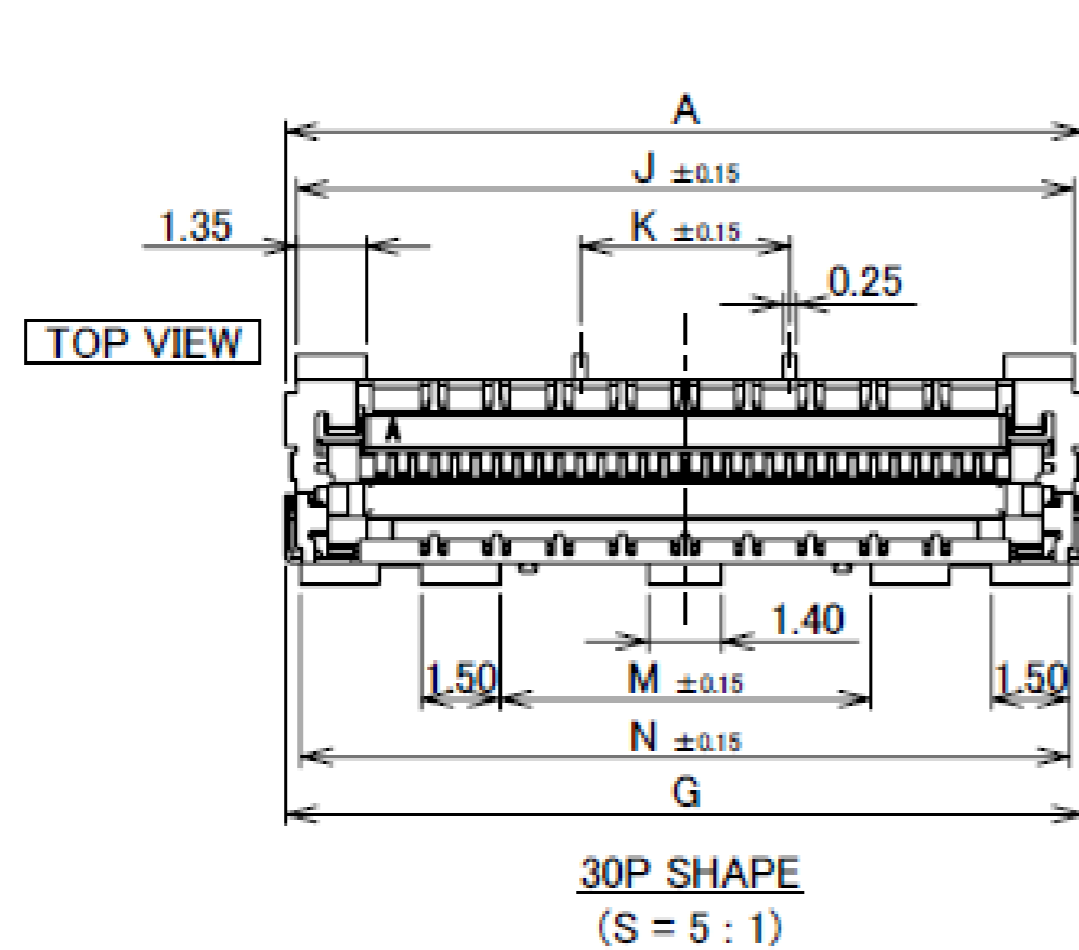

Rev.13

Receptacle Assembly

PART No.	Pos.	B	C	D	F	P	Q	R	S	T
20879-030E-#1	30	13.01	11.60	9.60	12.88	15.17	12.00	15.07	19.00	12.50
20879-040E-#1	40	17.01	15.60	14.40	16.88	19.17	16.00	19.07	23.00	16.50
20879-060E-#1	60	25.01	23.60	21.60	24.88	27.17	24.00	27.07	31.00	24.50

#1 TYPE

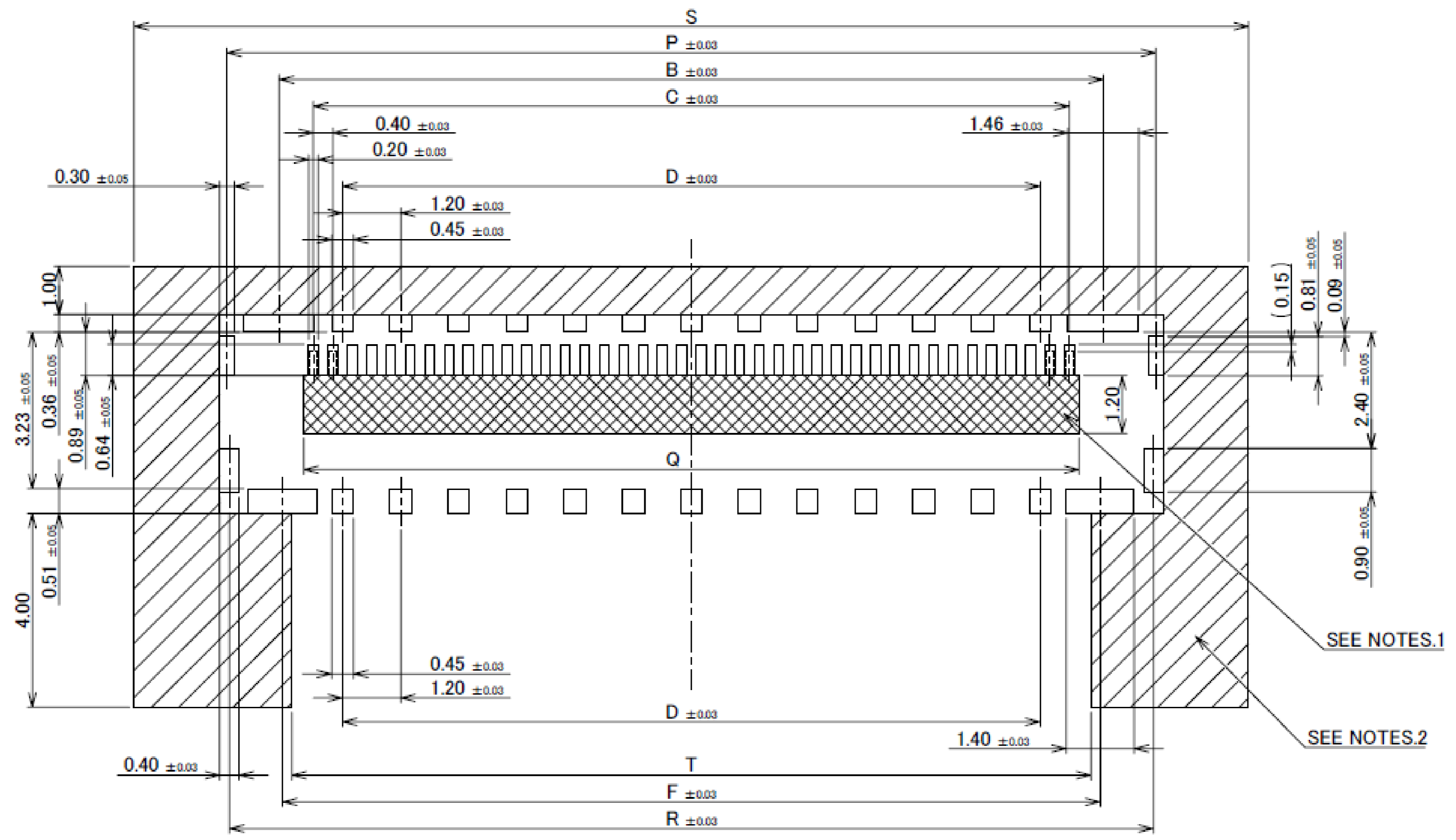

#1 TYPE 30P, 40P, 60P RECOMMENDED PCB LAYOUT
(S = 10 : 1)

- NOTES:
 1. SOLDER RESIST MUST BE APPLIED TO THIS AREA.
 2. DO NOT MOUNT ANOTHER COMPONENT IN THIS AREA.

Rev.13

PART No.	Pos.	B	C	D	F	P	Q	R	S	T
20879-050E-11	50	21.01	19.60	17.60	20.88	23.17	20.00	23.07	27.00	20.50

#1 TYPE

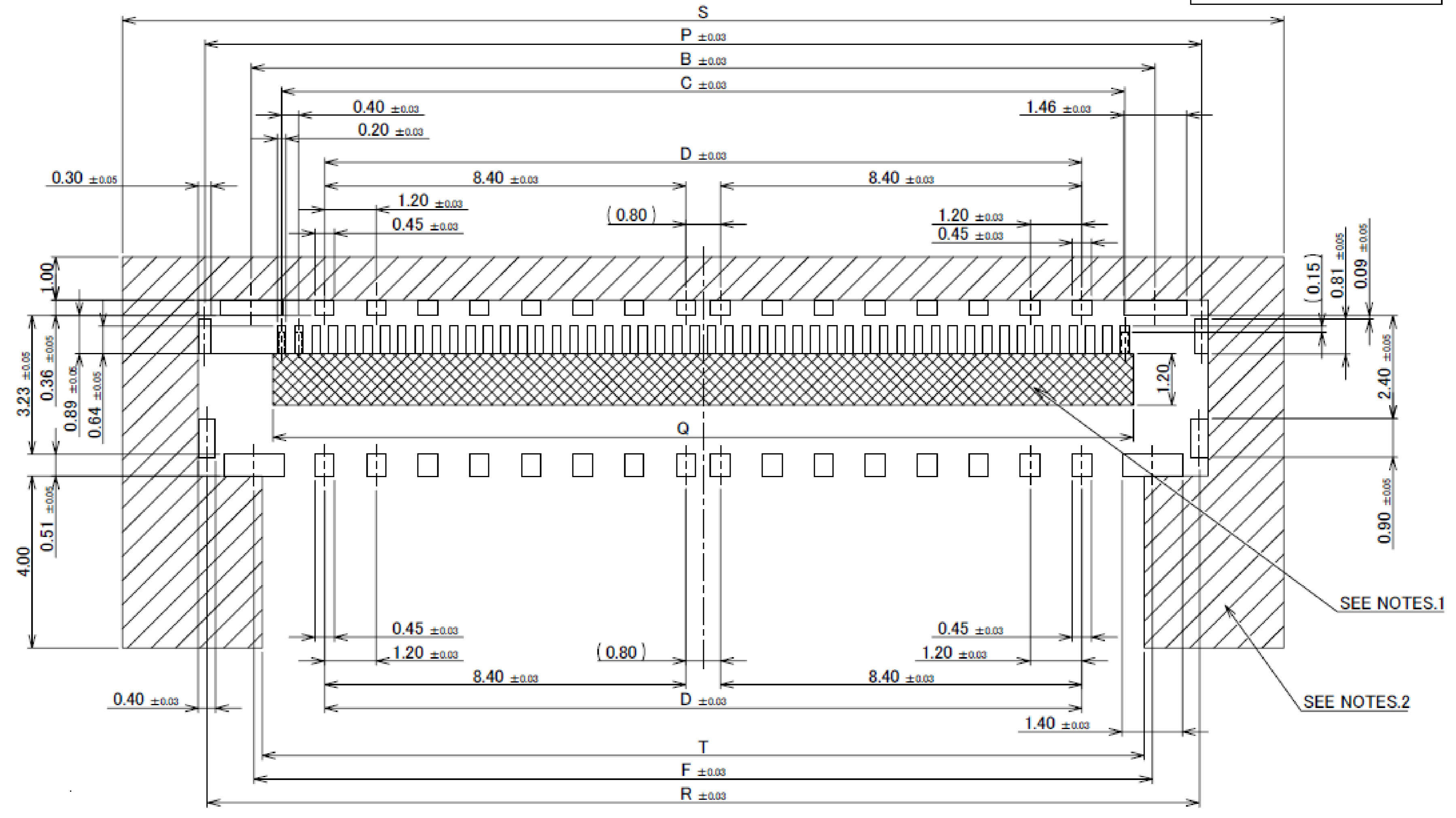

#1 TYPE 50P RECOMMENDED PCB LAYOUT
(S=10/1)

- NOTES:
 1. SOLDER RESIST MUST BE APPLIED TO THIS AREA.
 2. DO NOT MOUNT ANOTHER COMPONENT IN THIS AREA.

Rev.13

Receptacle Assembly

PART No.	Pos.
20879-030E-#1	30
20879-040E-#1	40
20879-060E-#1	60

#1 TYPE

With LOCK COVER

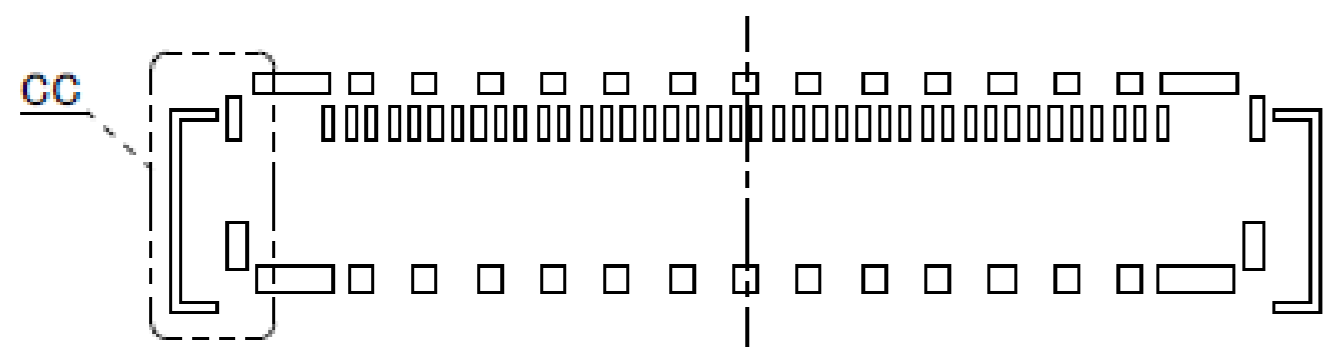

RECOMMENDED SILK PRINT For With LOCK COVER
(S = 5 : 1)

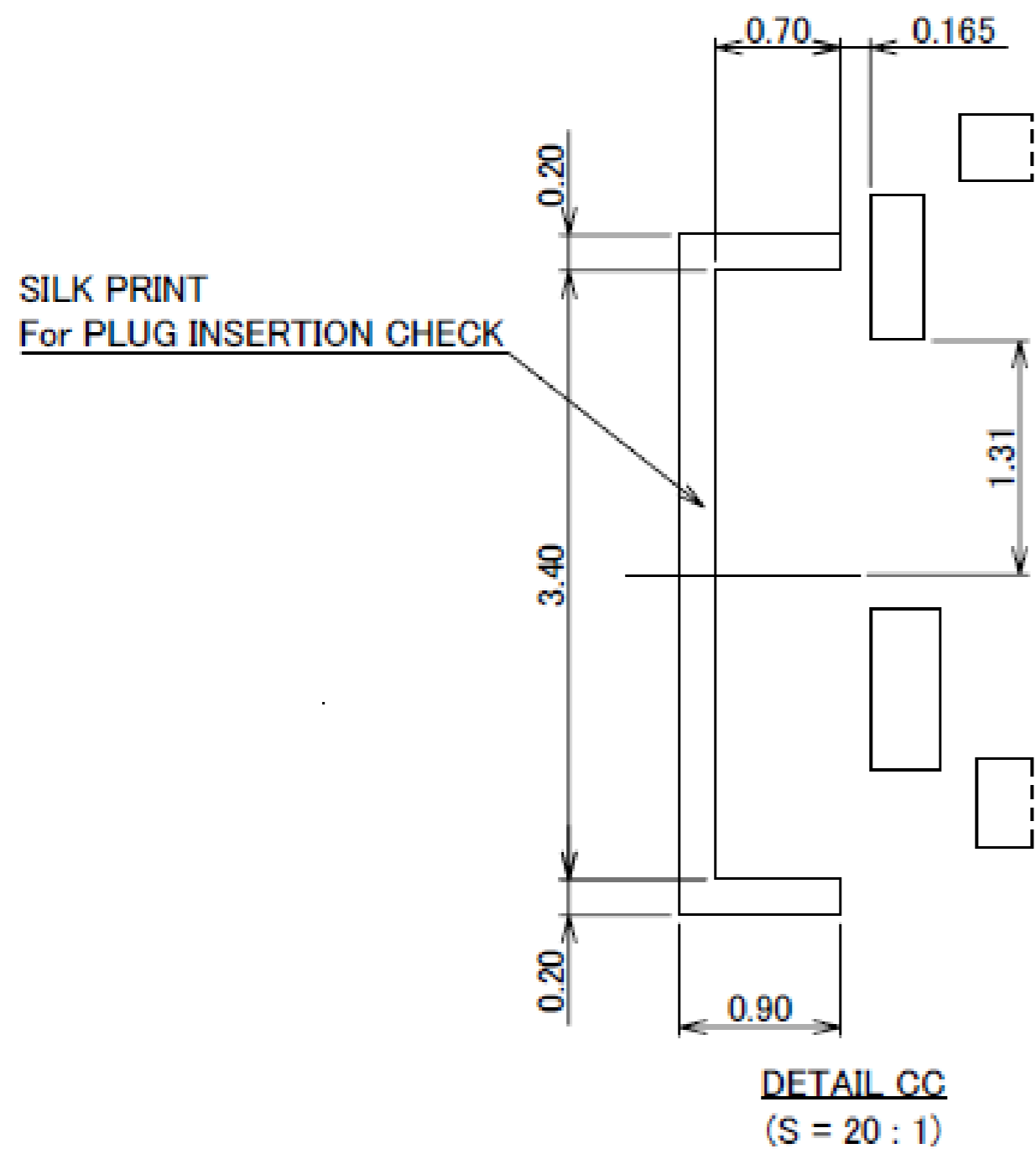

Without LOCK COVER & With PULL TAPE HOLDER

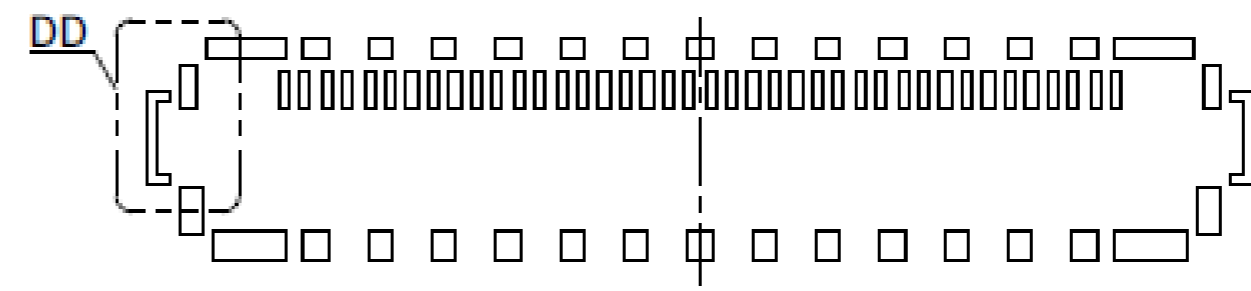

RECOMMENDED SILK PRINT For Without LOCK COVER
(S = 5 : 1)

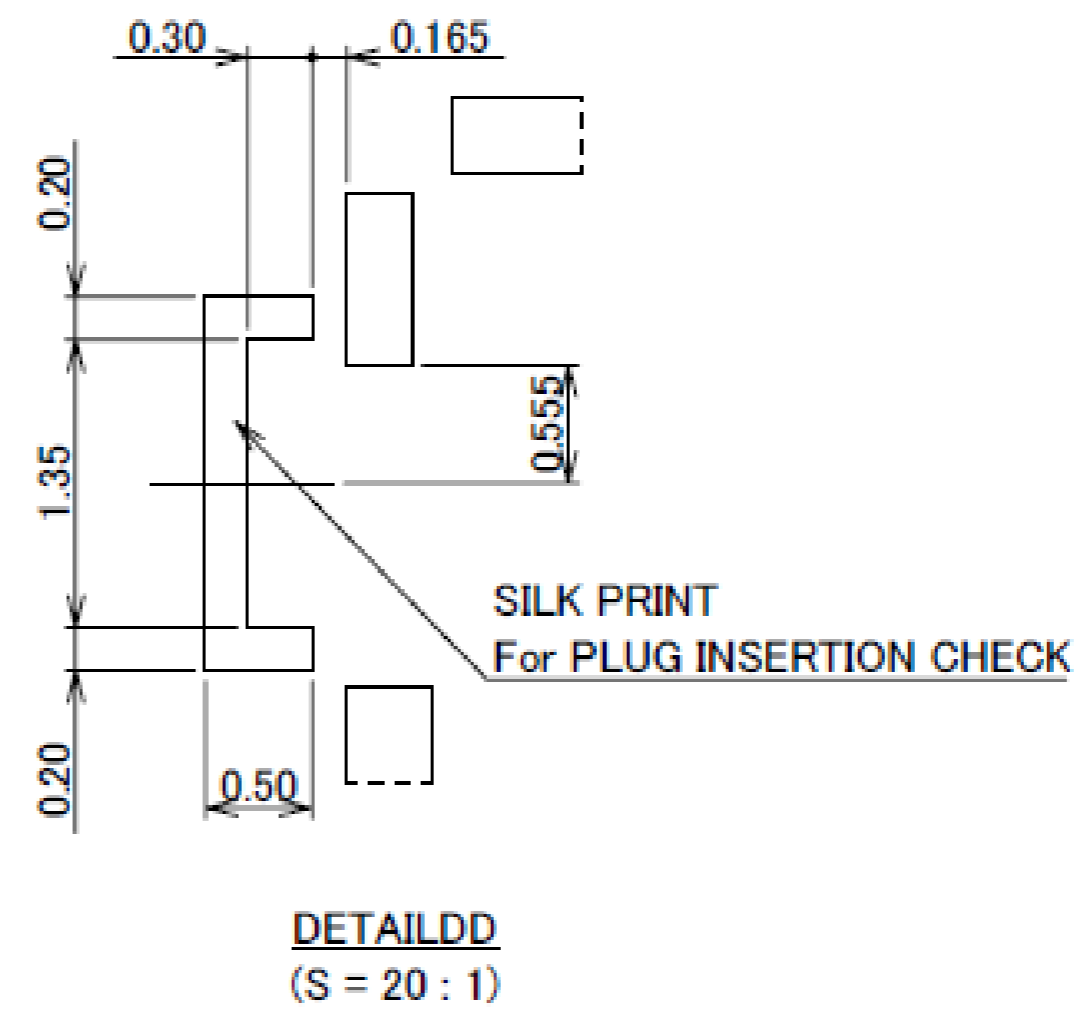

Rev.13

PART No.	Pos.	C	K	L	Q	S	T	U	V	W	X
20879-030E-02	30	11.60	4.00	-	12.00	19.00	12.50	6.89	15.07	14.89	15.47
20879-040E-02	40	15.60	8.00	4.00	16.00	23.00	16.50	6.50	19.07	18.89	19.47
20879-060E-02	60	23.60	17.60	11.20	24.00	31.00	24.50	10.50	27.07	26.89	27.47

02 TYPE

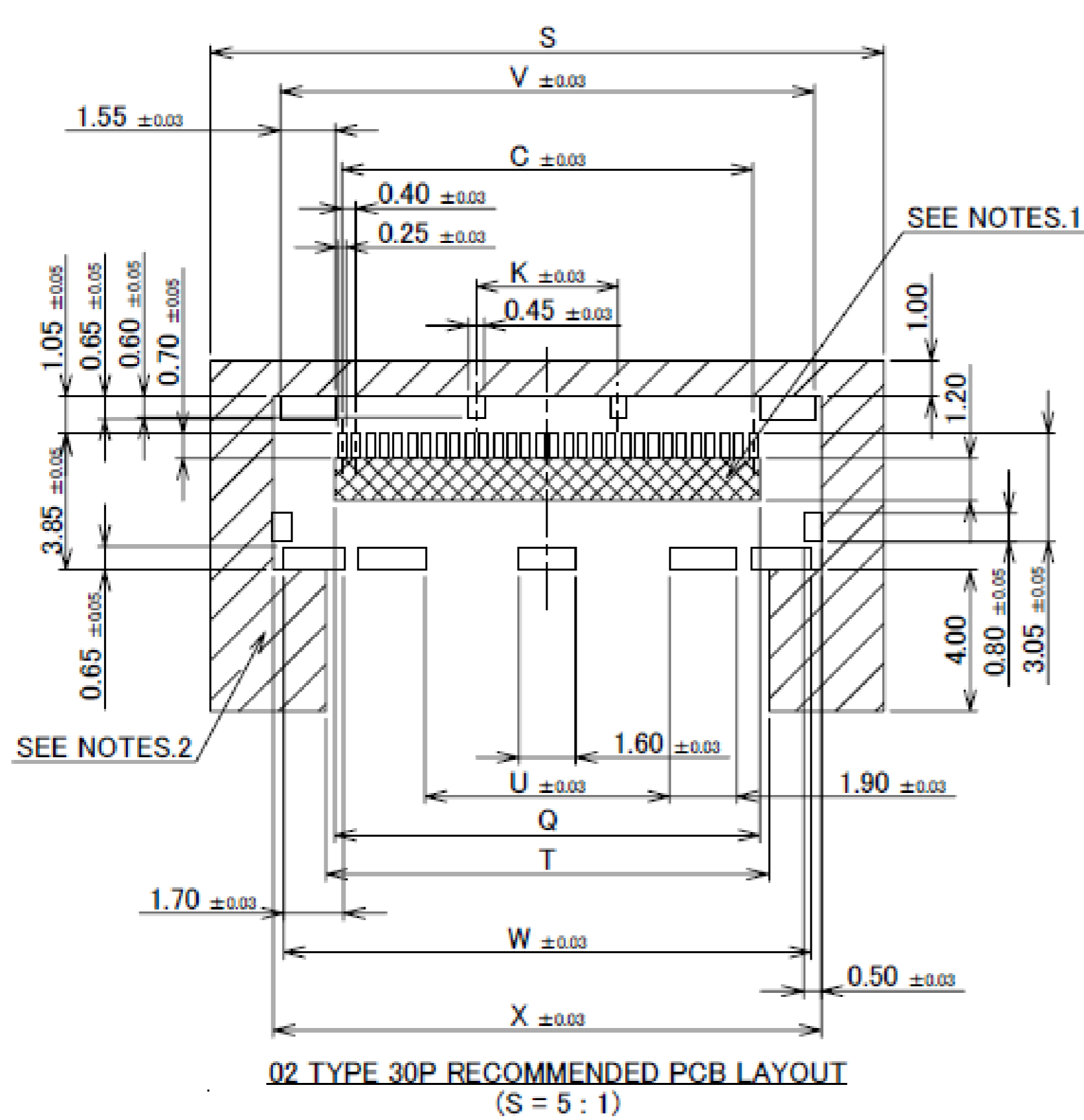

02 TYPE 30P RECOMMENDED PCB LAYOUT
(S = 5 : 1)

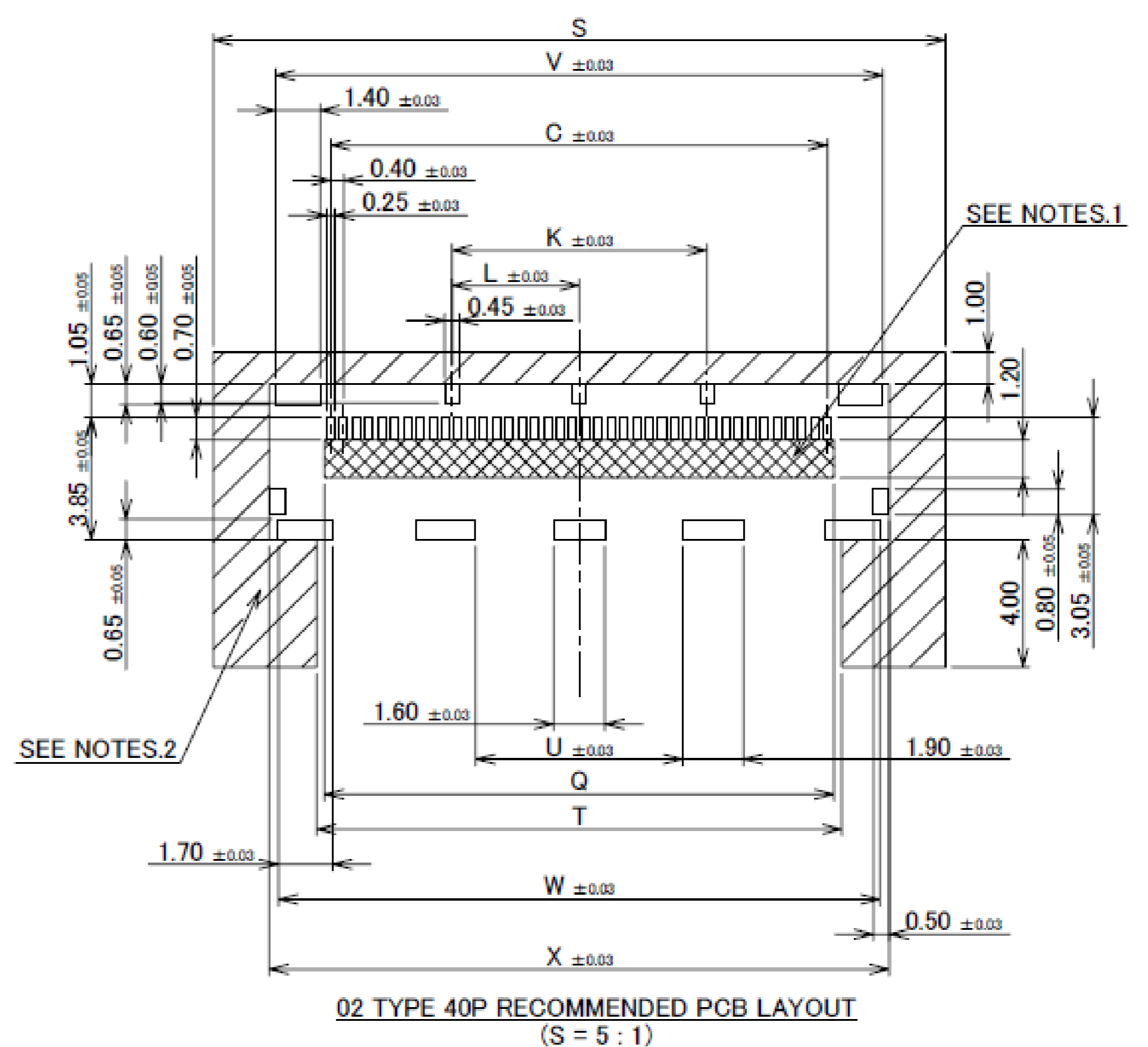

02 TYPE 40P RECOMMENDED PCB LAYOUT
(S = 5 : 1)

- NOTES.
1. SOLDER RESIST MUST BE APPLIED TO THIS AREA.
2. DO NOT MOUNT ANOTHER COMPONENT IN THIS AREA.

Rev.13

Receptacle Assembly

PART No.	Pos.	C	K	L	Q	S	T	U	V	W	X	AD
20879-030E-02	30	11.60	4.00	-	12.00	19.00	12.50	6.89	15.07	14.89	15.47	-
20879-040E-02	40	15.60	8.00	4.00	16.00	23.00	16.50	6.50	19.07	18.89	19.47	-
20879-060E-02	60	23.60	17.60	11.20	24.00	31.00	24.50	10.50	27.07	26.89	27.47	3.20

02 TYPE

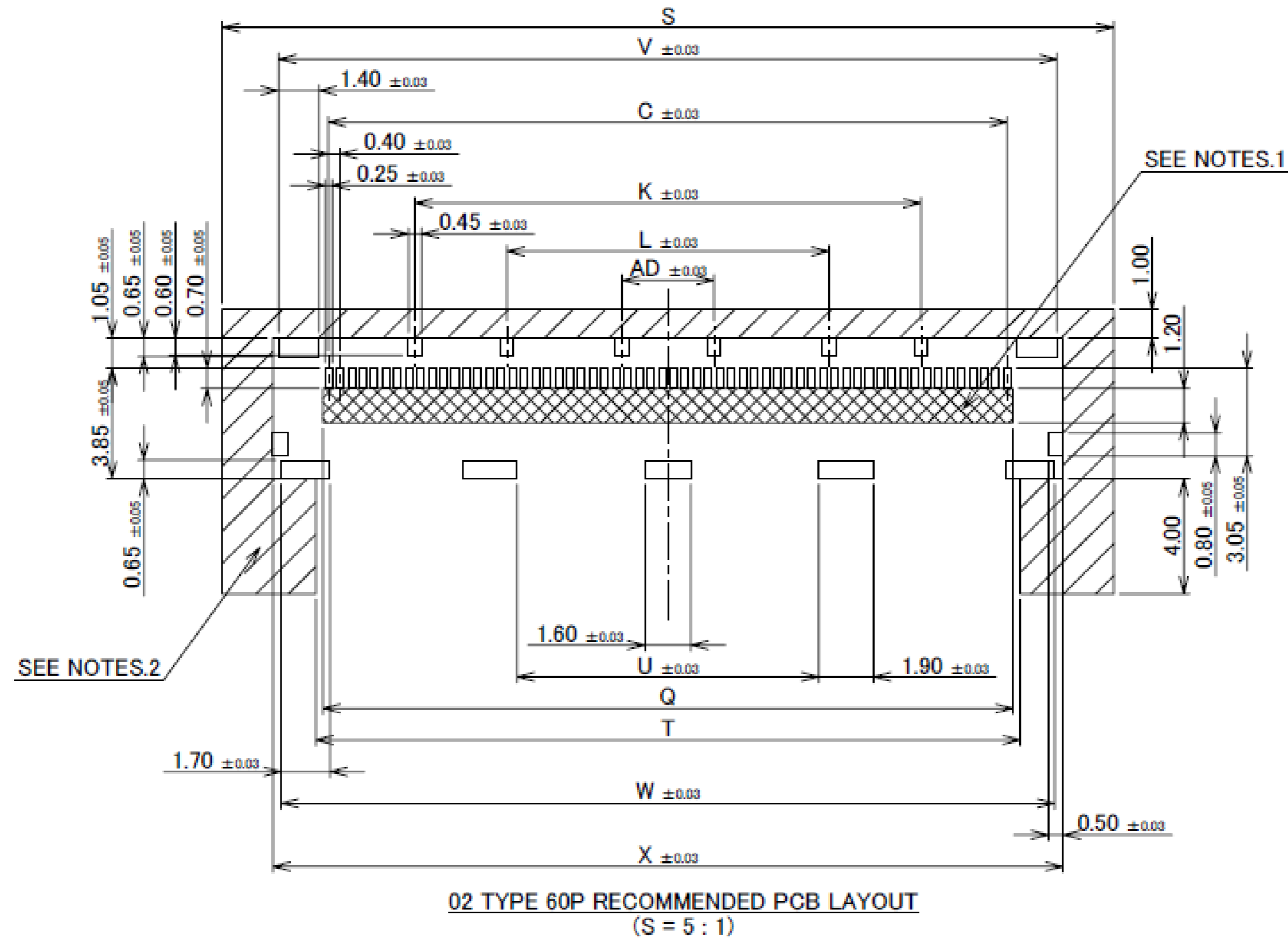

- NOTES.
 1. SOLDER RESIST MUST BE APPLIED TO THIS AREA.
 2. DO NOT MOUNT ANOTHER COMPONENT IN THIS AREA.

Rev.13

PART No.	Pos.	B	C	D	F	P	R
20879-030E-#1	30	13.01	11.60	9.60	12.88	15.17	15.07
20879-040E-#1	40	17.01	15.60	14.40	16.88	19.17	19.07
20879-060E-#1	60	25.01	23.60	21.60	24.88	27.17	27.07

#1 TYPE

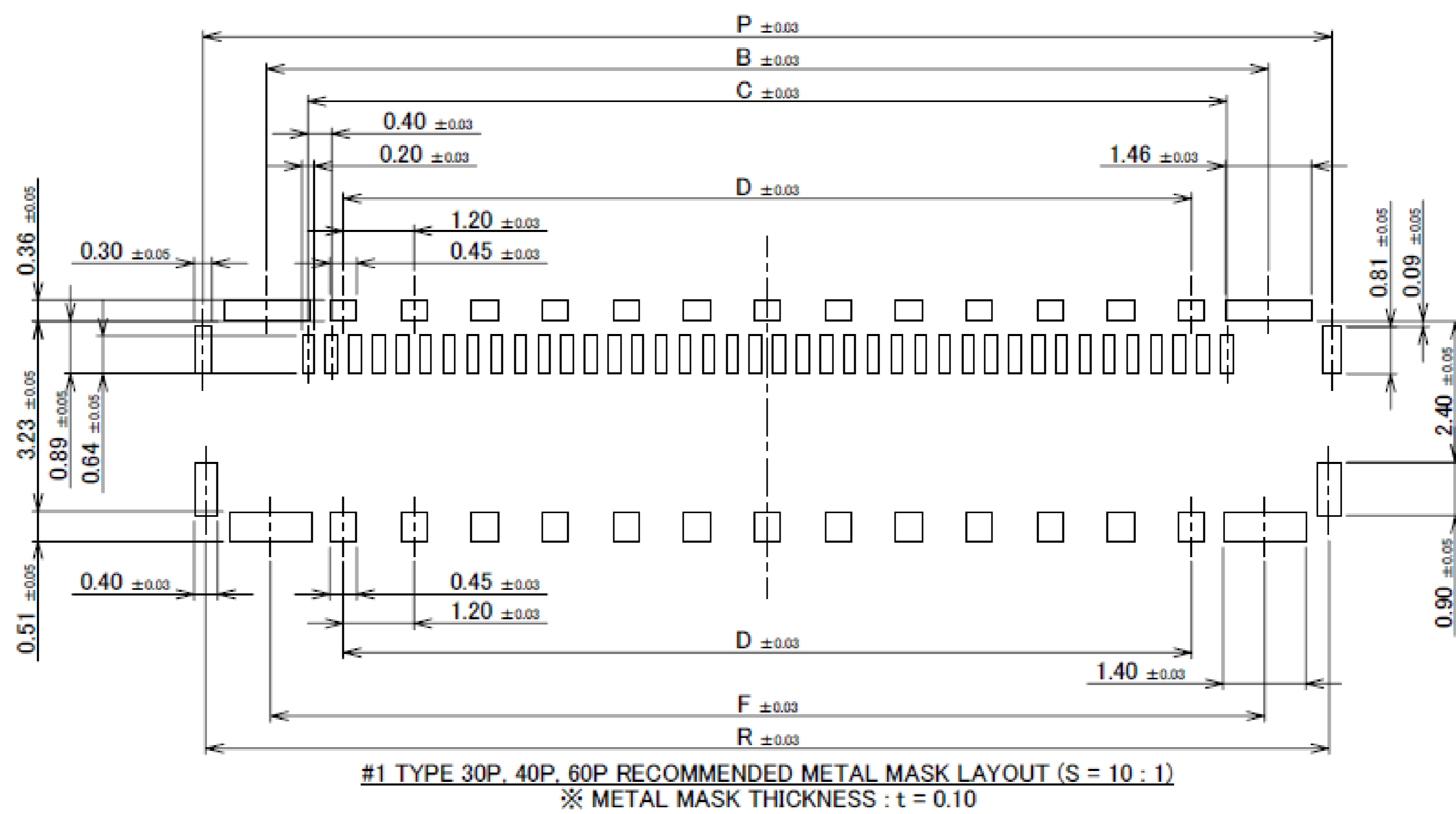

Rev.13

Receptacle Assembly

PART No.	Pos.	B	C	D	F	P	R
20879-050E-11	50	21.01	19.60	17.60	20.88	23.17	23.07

#1 TYPE

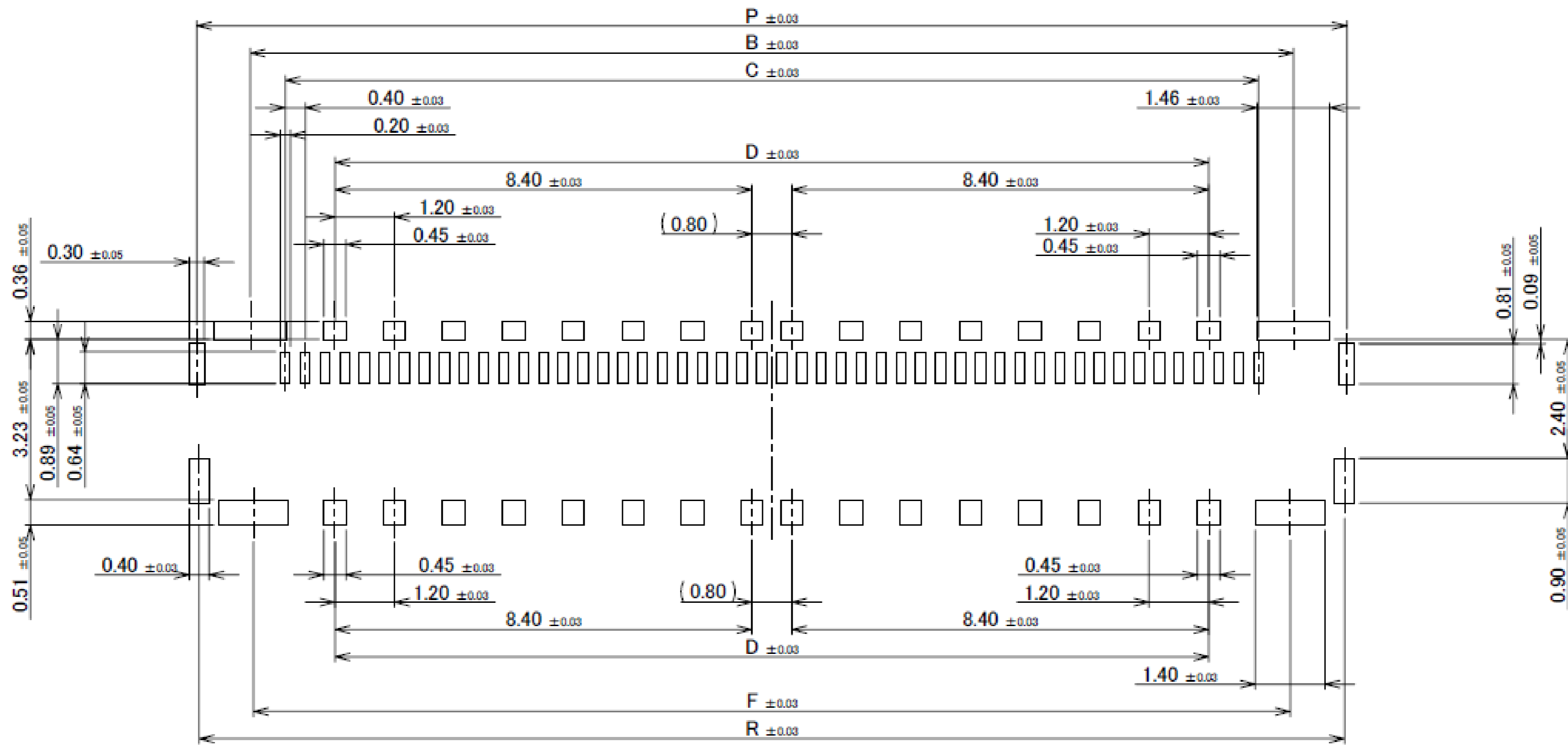

#1 TYPE 50P RECOMMENDED METAL MASK LAYOUT (S = 10 : 1)
※ METAL MASK THICKNESS : t = 0.10

Rev.13

PART No.	Pos.	C	K	L	U	V	W	X
20879-030E-02	30	11.60	4.00	-	6.89	15.07	14.89	15.47
20879-040E-02	40	15.60	8.00	4.00	6.50	19.07	18.89	19.47
20879-060E-02	60	23.60	17.60	11.20	10.50	27.07	26.89	27.47

PATENT PENDING

02 TYPE

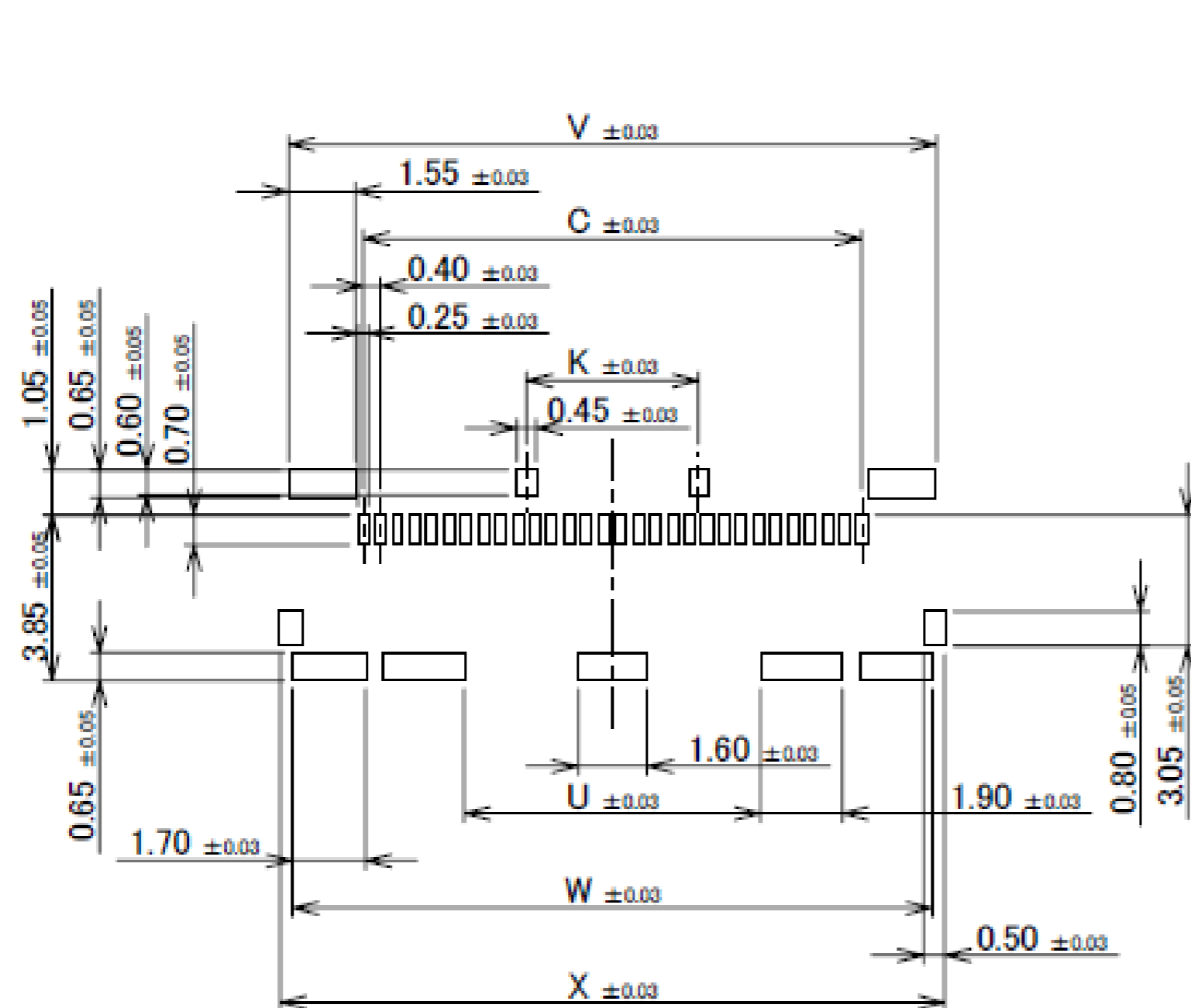

02 TYPE 30P RECOMMENDED METAL MASK LAYOUT (S = 5 : 1)
※ METAL MASK THICKNESS : t = 0.12

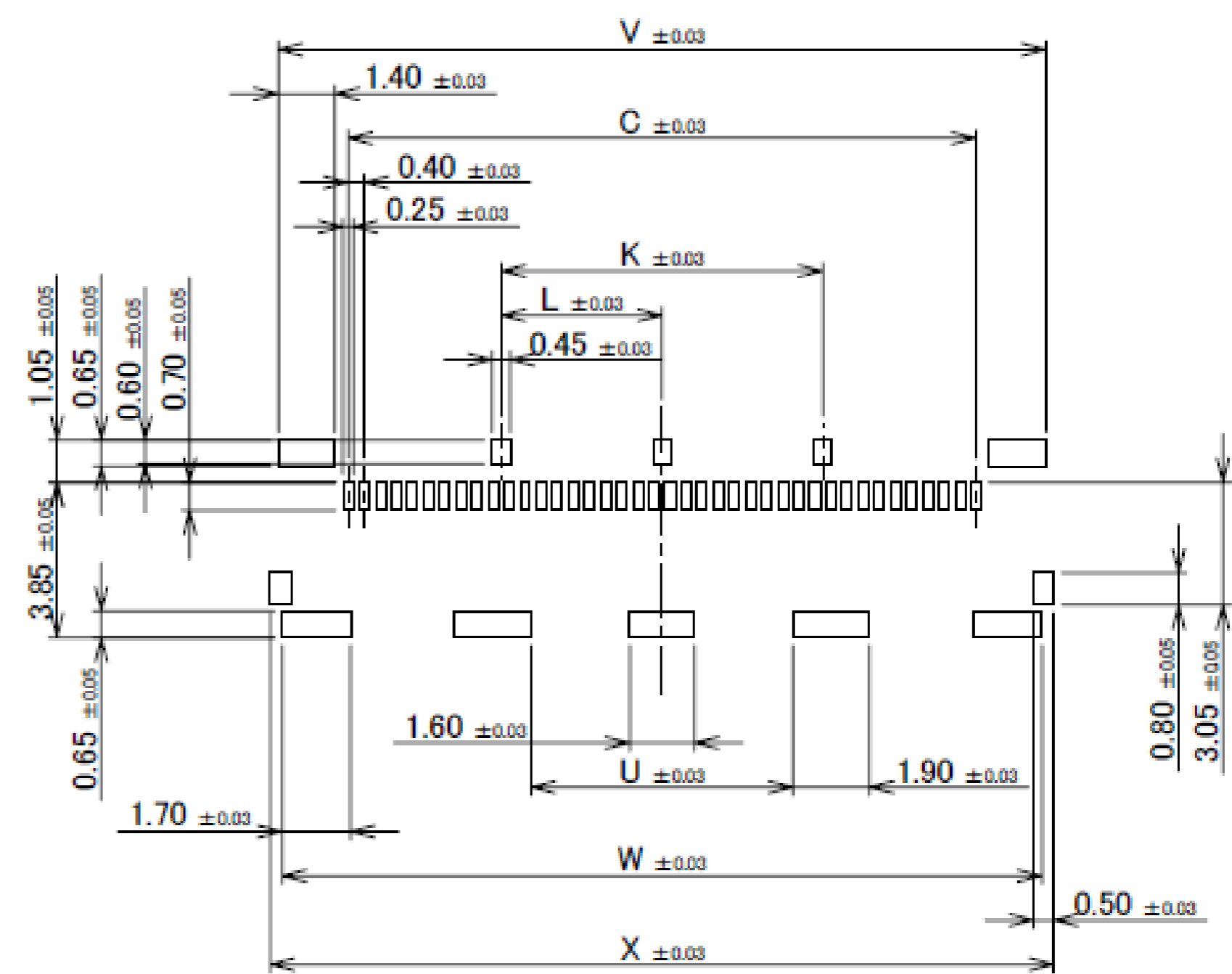

02 TYPE 40P RECOMMENDED METAL MASK LAYOUT (S = 5 : 1)
※ METAL MASK THICKNESS : t = 0.12

Rev.13

Receptacle Assembly

PART No.	Pos.	G	K	L	U	V	W	X	AD
20879-030E-02	30	11.60	4.00	-	6.89	15.07	14.89	15.47	-
20879-040E-02	40	15.60	8.00	4.00	6.50	19.07	18.89	19.47	-
20879-060E-02	60	23.60	17.60	11.20	10.50	27.07	26.89	27.47	3.20

02 TYPE

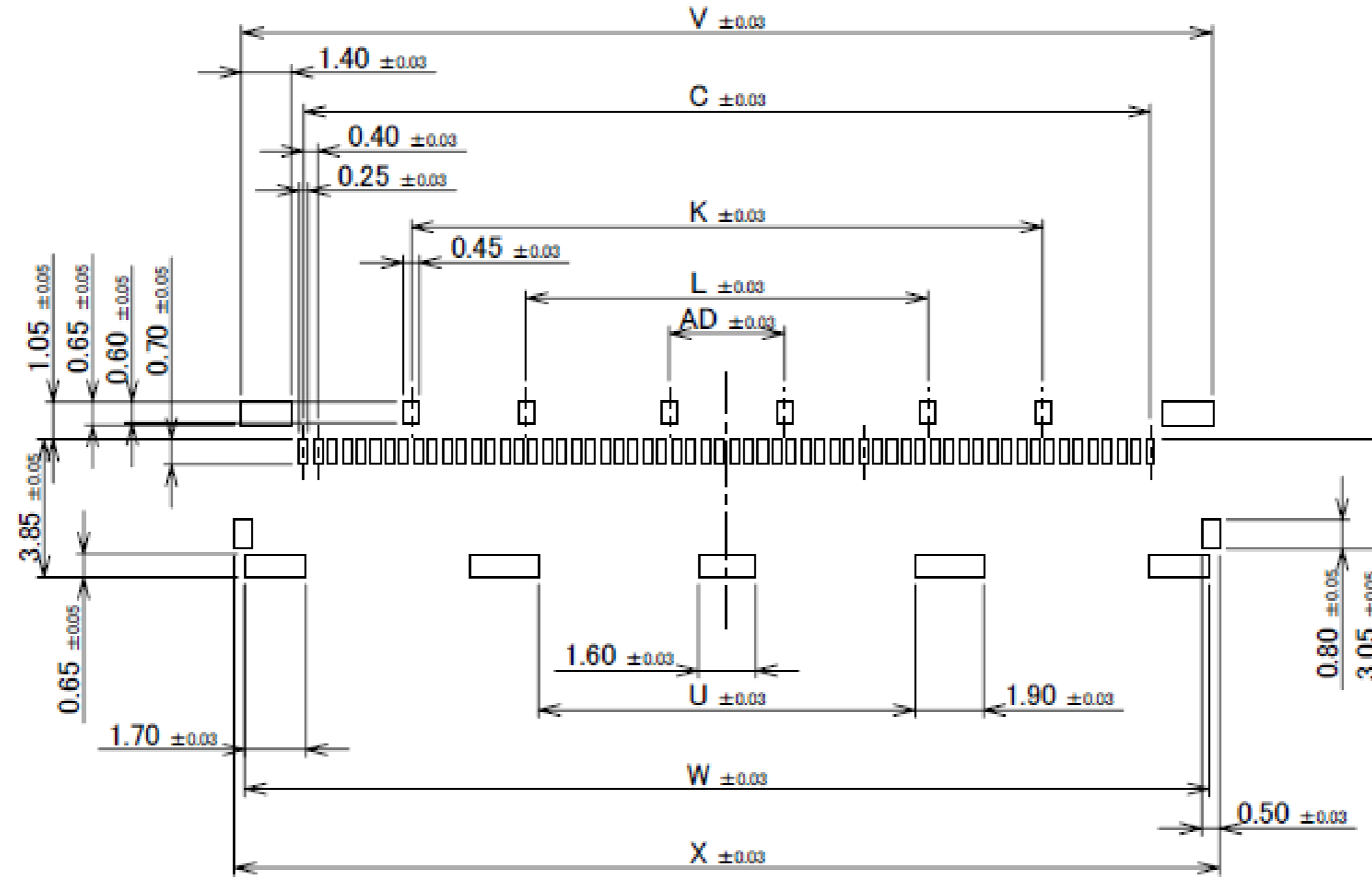

02 TYPE 60P RECOMMENDED METAL MASK LAYOUT (S = 5 : 1)
 ※ METAL MASK THICKNESS : t = 0.12

Rev.13

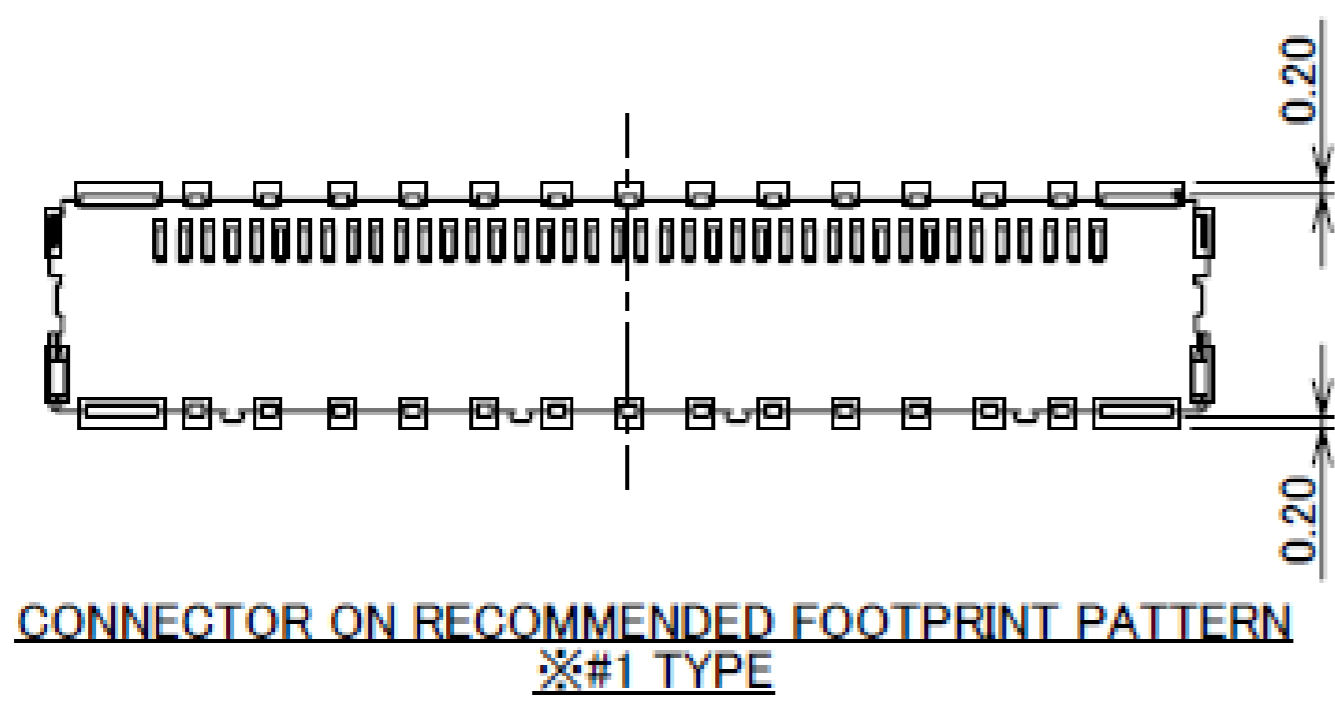

CONNECTOR ON RECOMMENDED FOOTPRINT PATTERN
 ※#1 TYPE

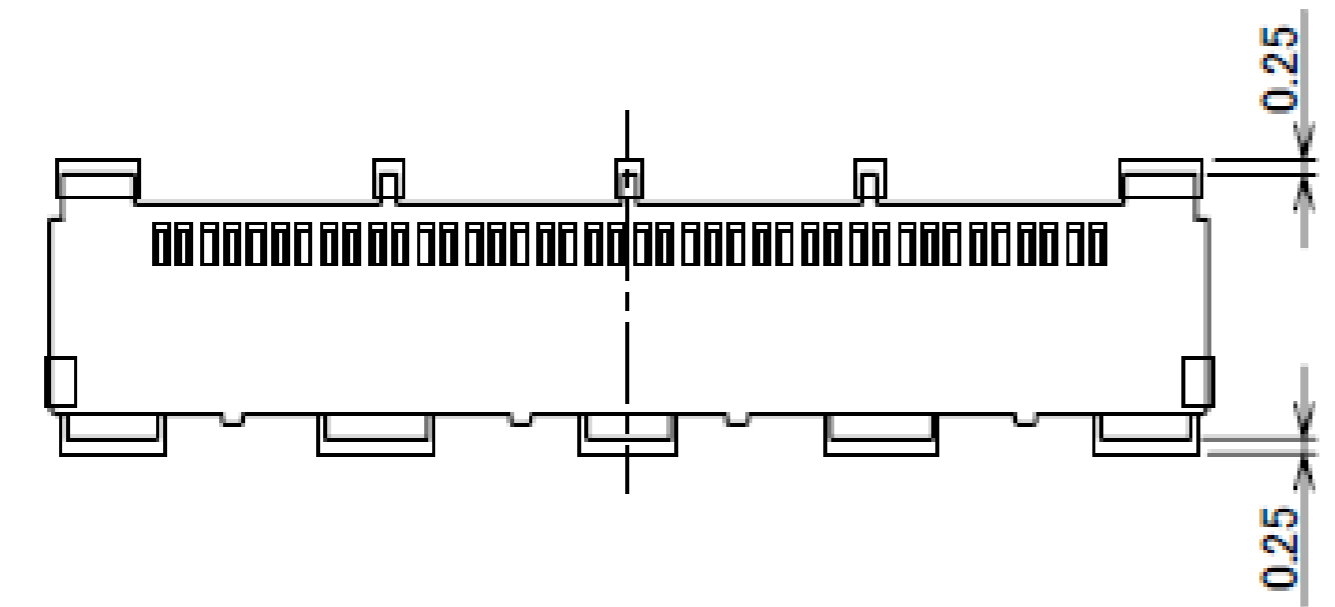

CONNECTOR ON RECOMMENDED FOOTPRINT PATTERN
 ※02 TYPE

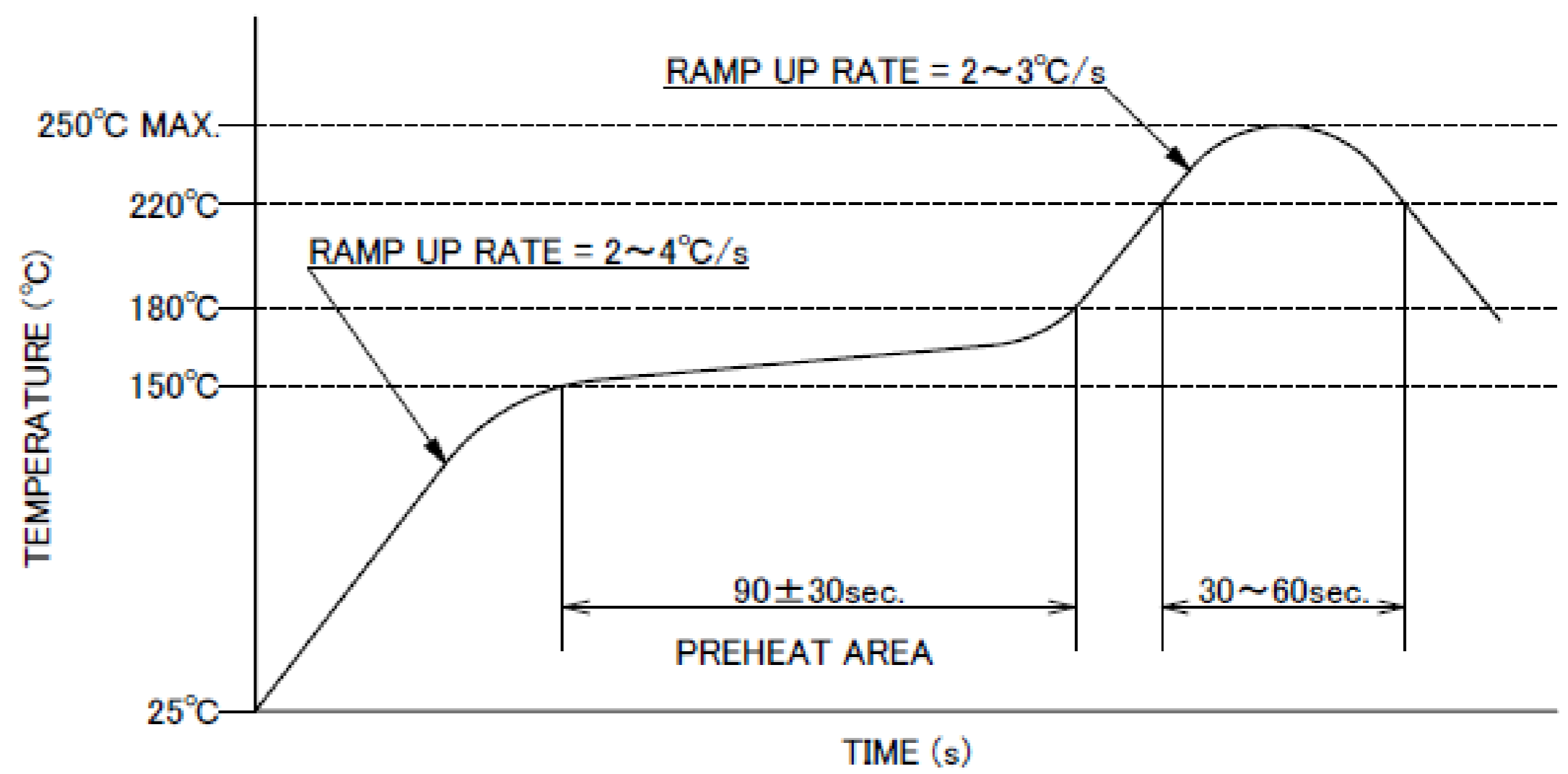

REFLOW TEMPERATURE PROFILE
 SENJU METAL INDUSTRY CO., LTD.: M705-SHF(Sn96.5 Ag3.0 Cu0.5)

Rev.13

ITEMS	SPECIFICATION
APPLICABLE CABLE	MICRO-COAXIAL CABLE : AWG# 44 , 42 , 40 , 38 , 36 DISCRETE WIRE : AWG# 36 , 34 TWINAX CABLE : AWG# 40 , 42
RATING VOLTAGE	100V AC (PER CONTACT PIN)
RATING AMPERAGE (FOR CONTACT)	0.15A AC/DC [AWG#44] PER CONTACT PIN/UP TO 60 CONTACTS 0.24A AC/DC [AWG#42] PER CONTACT PIN/UP TO 49 CONTACTS 0.3A AC/DC [AWG#40] PER CONTACT PIN/UP TO 38 CONTACTS 0.5A AC/DC [AWG#38] PER CONTACT PIN/UP TO 19 CONTACTS 0.8A AC/DC [AWG#36] PER CONTACT PIN/UP TO 12 CONTACTS 1.0A AC/DC [AWG#34] PER CONTACT PIN/UP TO 10 CONTACTS ※TESTING BY A REAL MACHINE IS RECOMMENDED BECAUSE TEMPERATURE RISE MAY AFFECTED BY ACTUAL SITUATION.
OPERATING TEMPERATURE	233~378K(-40°C~+105°C)
OPERATING HUMIDITY	85% MAX.(NON-CONDENSING)
CONTACT RESISTANCE	INITIAL : 180mohm MAX.(AWG#34) / AFTER TEST : \triangle 40mohm MAX. 275mohm MAX.(AWG#36) 380mohm MAX.(AWG#38) 600mohm MAX.(AWG#40) 700mohm MAX.(AWG#42) 1080mohm MAX.(AWG#44)
GROUND SHELL RESISTANCE	INITIAL : 50mohm MAX. / AFTER TEST : \triangle 40mohm MAX.
INSULATION RESISTANCE	INITIAL : 1000Mohm MIN. / AFTER TEST : 500Mohm MIN.
DIELECTRIC WITHSTANDING VOLTAGE	AC250V 1min
DURABILITY	30 CYCLES
MATING FORCE (INITIAL / AFTER TEST)	30P : 34.00N MAX. 50P : 46.00N MAX. 40P : 40.00N MAX. 60P : 52.00N MAX.
UNMATING FORCE (INITIAL / AFTER TEST)	30P : 3.0N MIN. 50P : 5.0N MIN. 40P : 4.0N MIN. 60P : 6.0N MIN.
CABLE RETENTION FORCE	30P : 14.70N MIN. 50P : 24.50N MIN. 40P : 19.60N MIN. 60P : 29.40N MIN.
PRODUCT SPECIFICATION	PRS-2514
TEST REPORT	TR-18067 (RECEPTACLE:20879-0**E-01) TR-18088 (RECEPTACLE:20879-0**E-02)
INSTRUCTION MANUAL	HIM-18033
ASSEMBLY MANUAL	ASM-18003
APPEARANCE CRITERIA No.	QLS-A***

Rev.14

Custom Connectors Available

 RF Connector

MHF® series



CABLINÉ® series
Micro-coaxial/Twinax/
Discrete Wire Connector

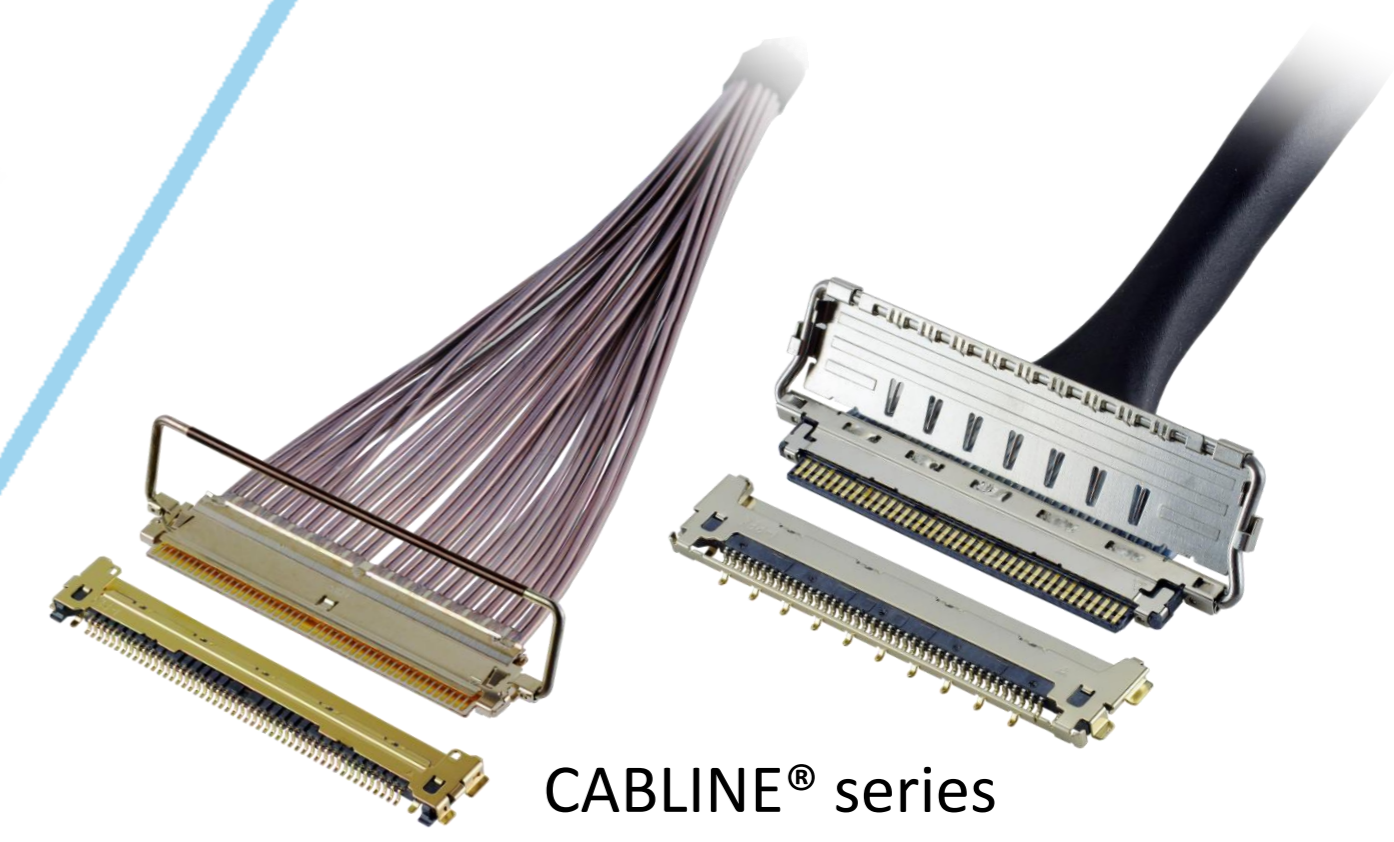

Optical Module

LIGHTPASS® series



NOVASTACK® series



Board-to-Board Connector

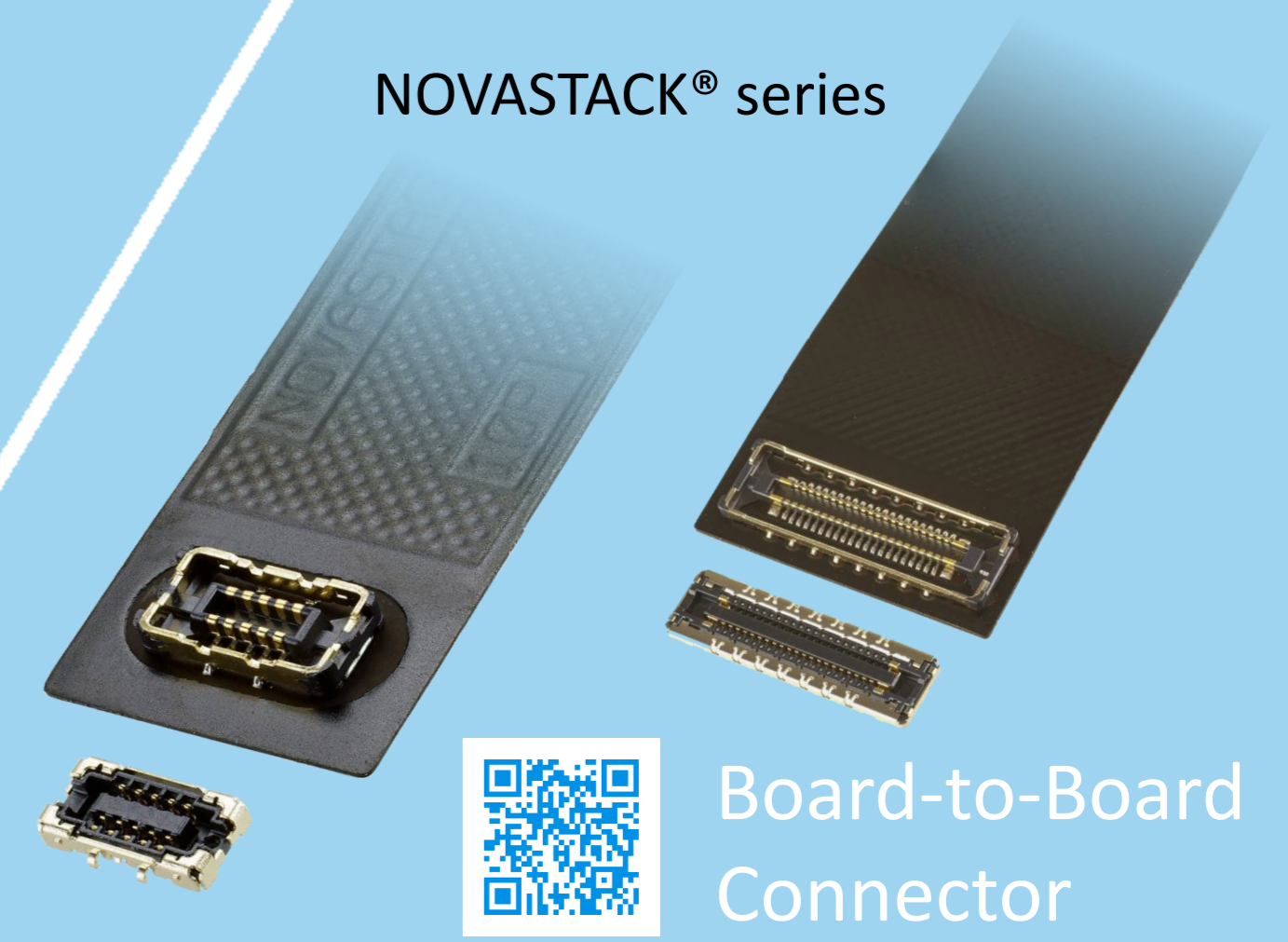

Power Connector/
Terminal

AP series

ISH® series



MINIFLEX® series

EVAFLEX® series



FPC FFC Connector



Inquiry



MINIDOCK® series



I/O Connector

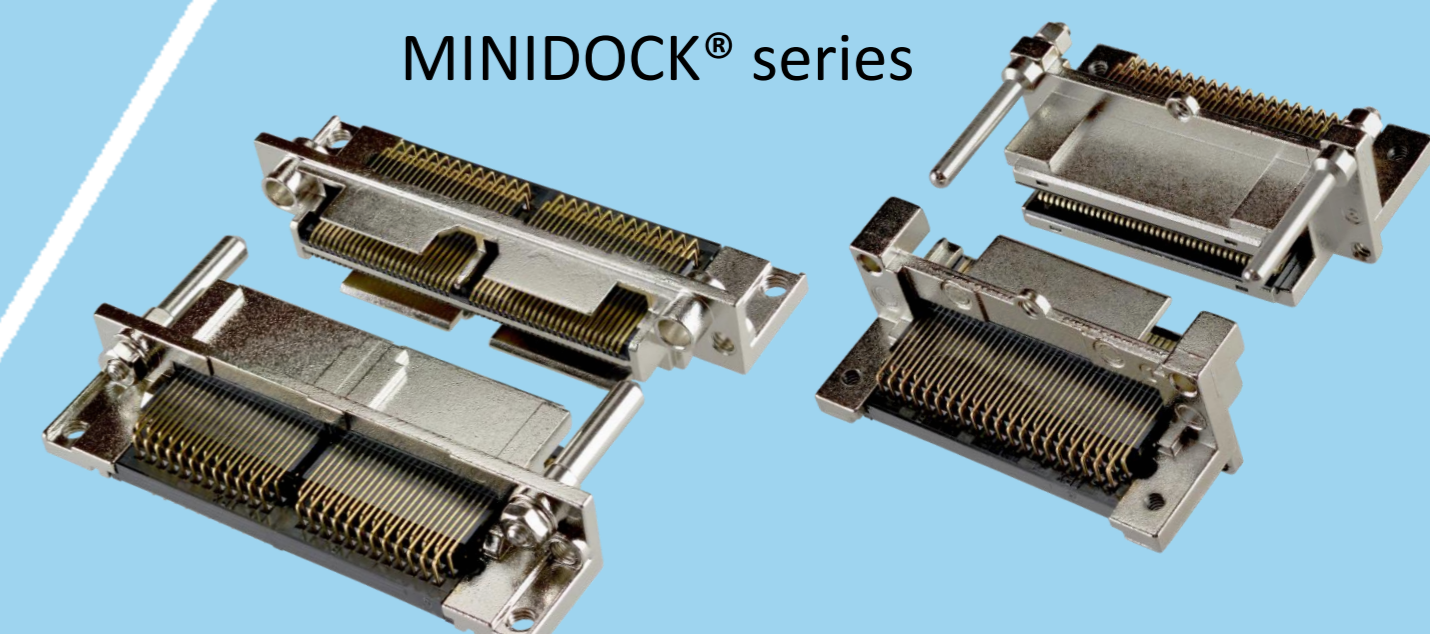

I-PEX, MHF, CABLINE, LIGHTPASS, NOVASTACK, ISH, IARPB, MINIFLEX, EVAFLEX, MINIDOCKS and ZenShield are registered trademarks of I-PEX Inc. Please note that the contents in the catalog might be changed without prior notification. I-PEX Inc. assumes no responsibility for any inaccuracies or obligation to update information on these documents. Please be sure to read and understand the latest "Precautions for Use" and "Instruction Manual" before you use our products. We shall not be responsible for any defects, damages or troubles in case you use our products without following the precautions for use. Please feel free to contact our sales representatives when you use our products for any applications that require very high reliability and safety, or that relate to human life (ex. nuclear power control, aerospace, transportation, medical equipment, safety equipment etc.).

Contact your sales representative or more detailed information.

www.i-pex.com



I-PEX

© I-PEX Inc. 2024
All rights reserved