

# CABLINE®-CA

고속 전송 대응, 기계식 Lock, 실드, 멀티 그라운드 접점, 0.4mm Pitch, 수평 결합 타입 세션 동축 커넥터

\*더욱 고속 64 Gbps PAM4에는 CABLINE-CA리셉터클(20525-050E-02)과 결합하는 CABLINE-CAP하네스 솔루션을 확인하십시오.

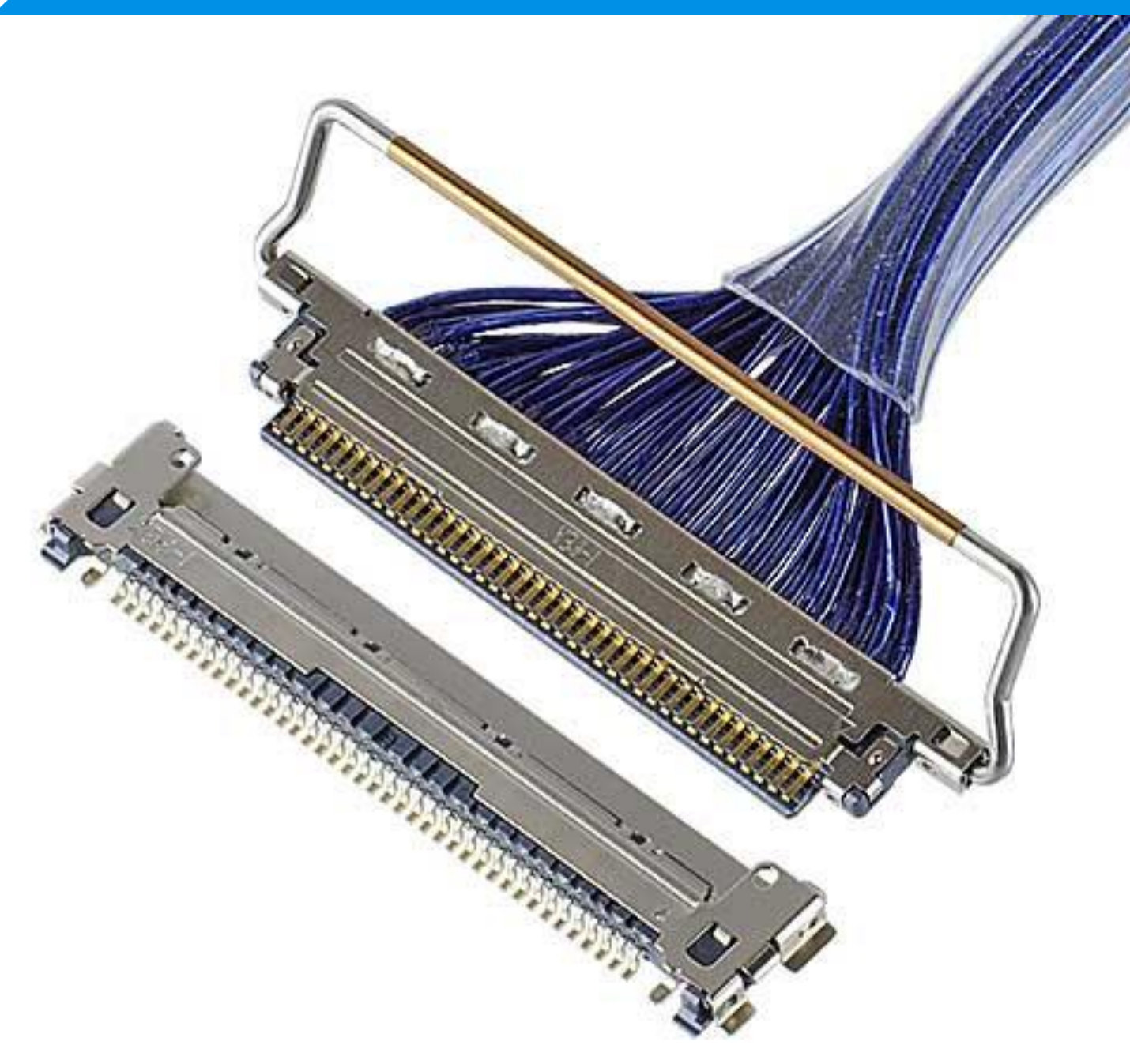

**Product Specifications:**

Mating type	Horizontal	
Board Pitch (mm)	0.4	
Wiping Length (mm)	0.54	
Mated size (mm)	Height	1.0 +/- 0.1
	Width	Formula: 6.95 + (0.4*?p)
	Depth	5.73
Pin Counts	Range	Up to 60
	Available	10, 12, 20, 30, 40, 50, 60

**Applicable Cable Size:**

Maximum O.D. (mm)	0.4
Micro-Coaxial for Signal (AWG)	45 ohm: #38 or smaller 50 ohm: #40 or smaller
Twinax (AWG)	#40
Discrete (AWG)	#34 or smaller

**Applicable Standards (Reference Only):**

USB4 Gen3/Thunderbolt 4 (20 Gbps/lane), PCIe Gen 4 (16 GT/s), USB 3.1 Gen 2 (10 Gbps), eDP HBR 3 (8.1 Gbps)

\*기재가 되어있지 않은 핀 수의 대응 여부에 대해서는 문의해 부탁드립니다.

## ▶ USB4 Gen3/Thunderbolt 4 (20Gbps/lane)의 고속 전송 내부 접속에 최적

USB4 Gen3/Thunderbolt 4(20Gbps/lane)

아이 패턴(차동)  
비트 전송률: 20Gbps  
상승 시간: 30ps(10-90%)  
입력 전압: 800mVp-p

\*자세한 테스트 정보는 I-PEX Connectors에 문의하십시오.

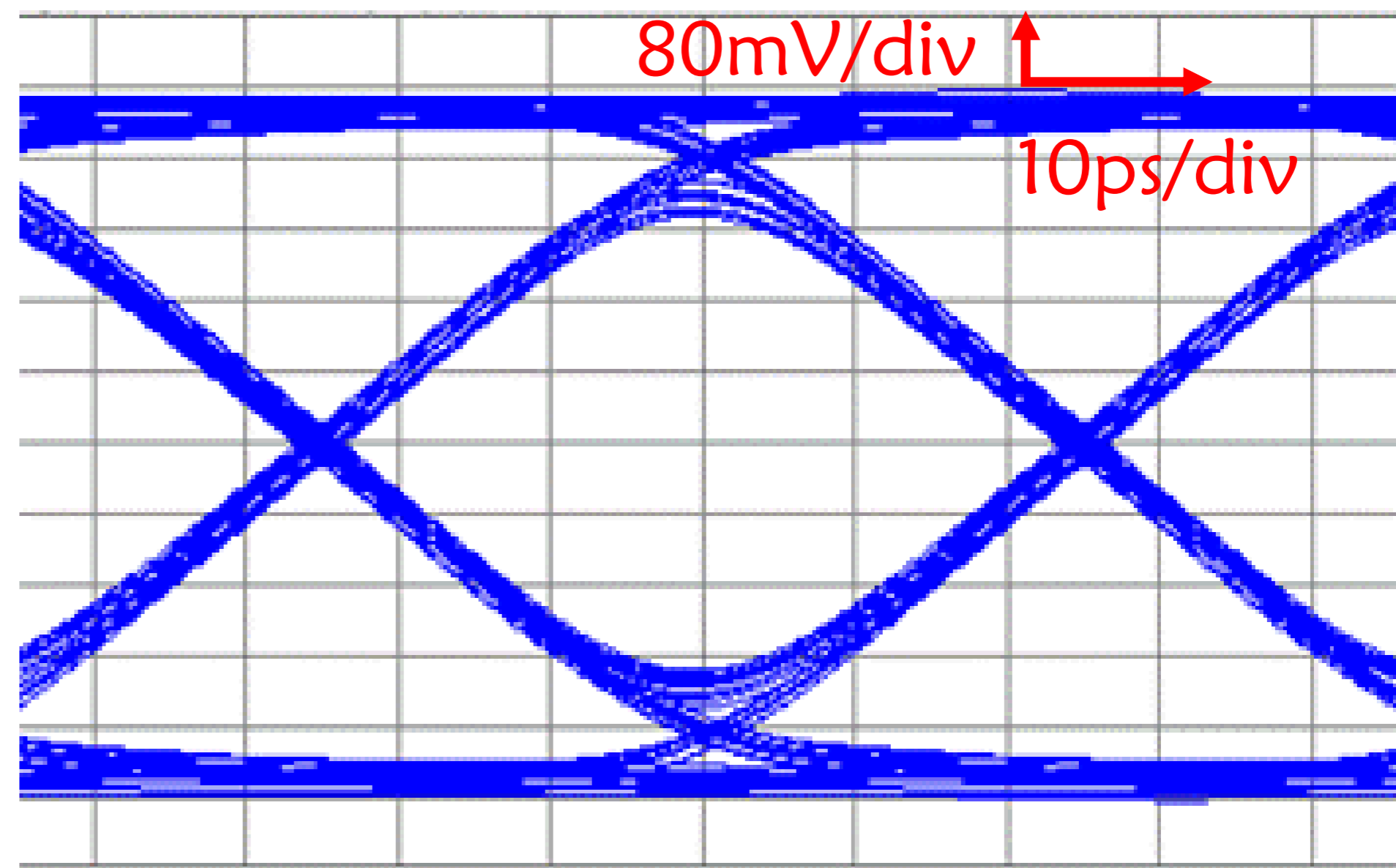

## ▶ 기계식 Locking bar에 의한 불완전 결합 방지와 Plug 이탈 방지

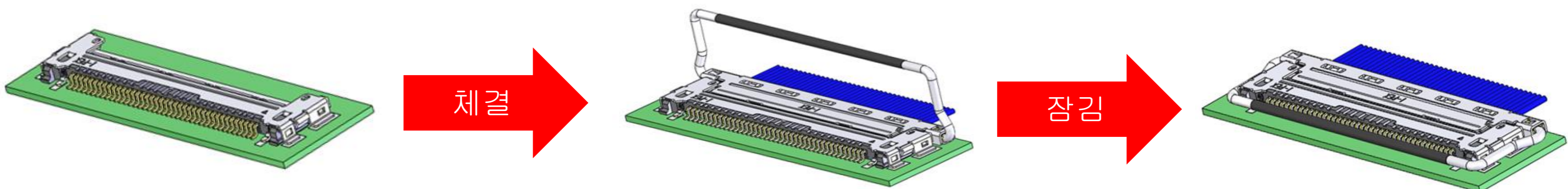

잠금 Bar는 플러그가 리셉터클에 완전히 체결된 경우에만 잠글 수 있습니다.

간섭

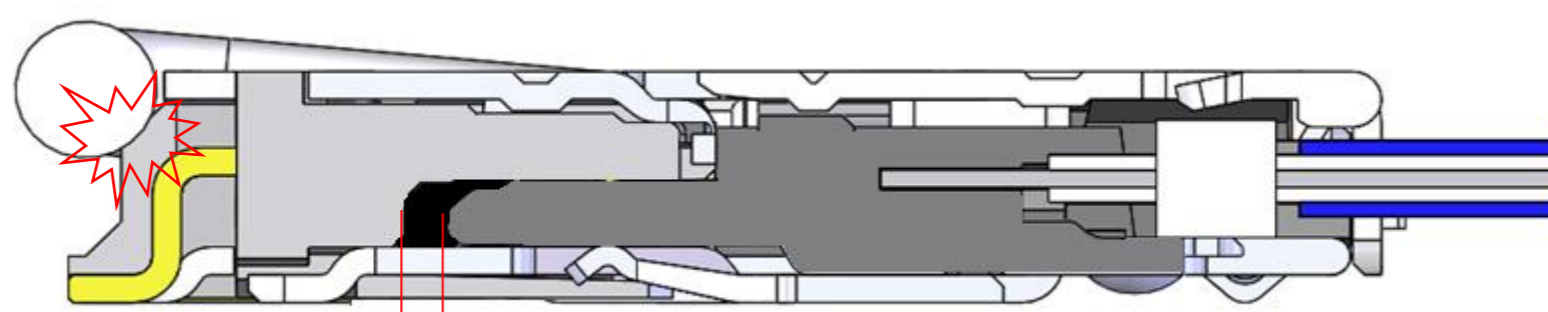

불완전한 체결

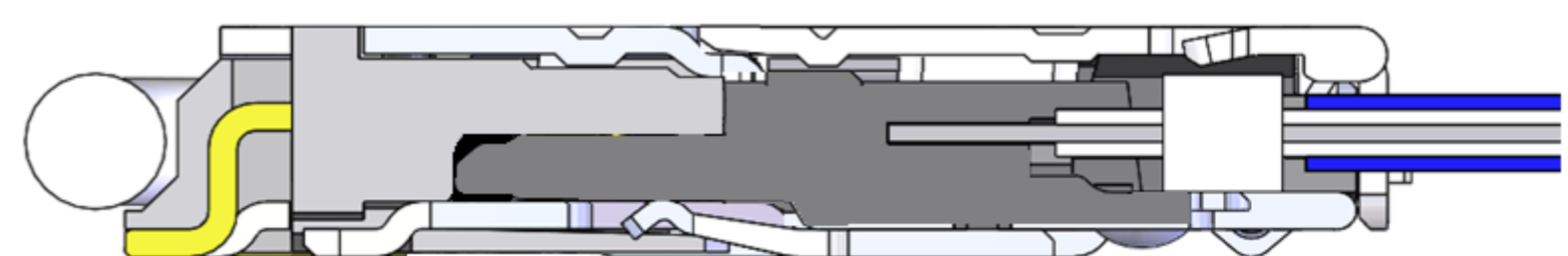

완전한 체결

## ▶ CABLINE-CA 시리즈의 다양한 커넥터 접속 옵션

CABLINE-CA 시리즈(0.4mm 피치, 수평 메이팅 유형)

CABLINE-CA 및 CA II 리셉터클은 동일PCB 레이아웃을 사용 가능.

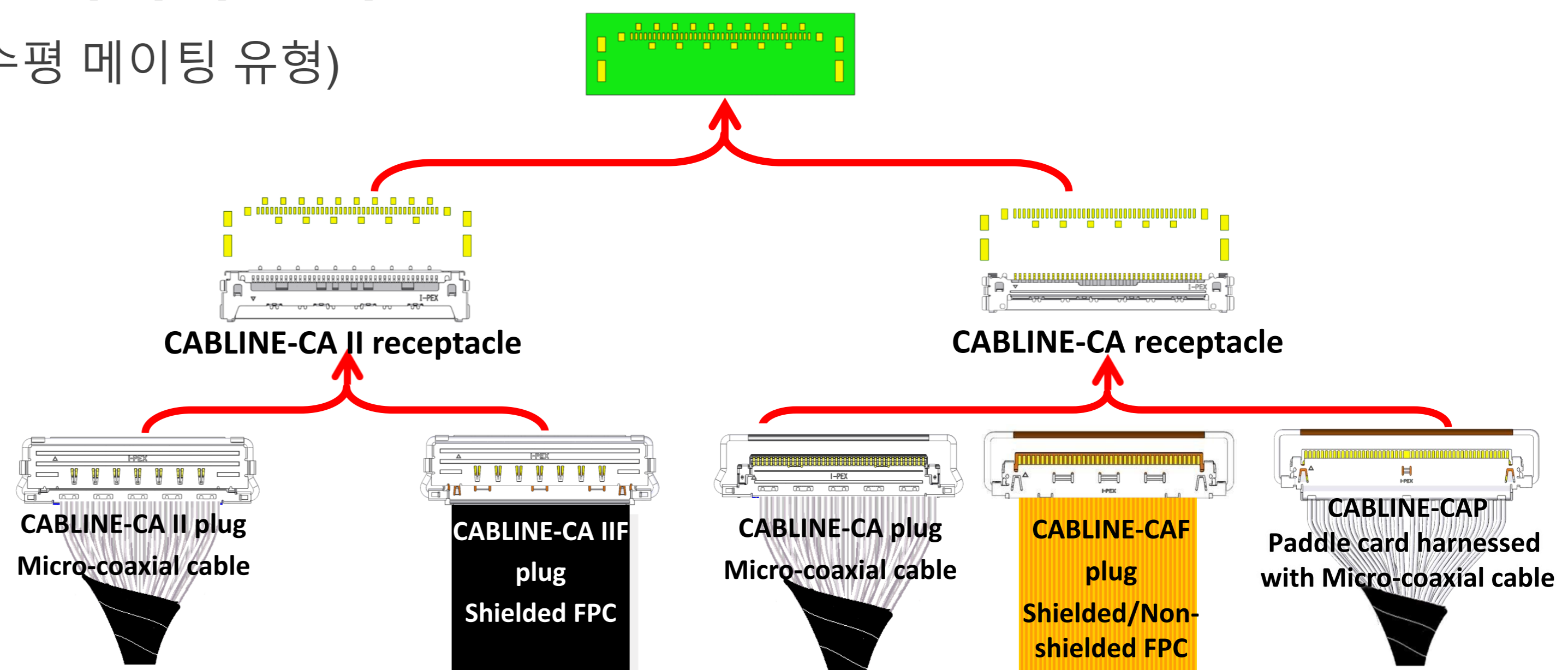

# Component Parts Details

## Component Parts

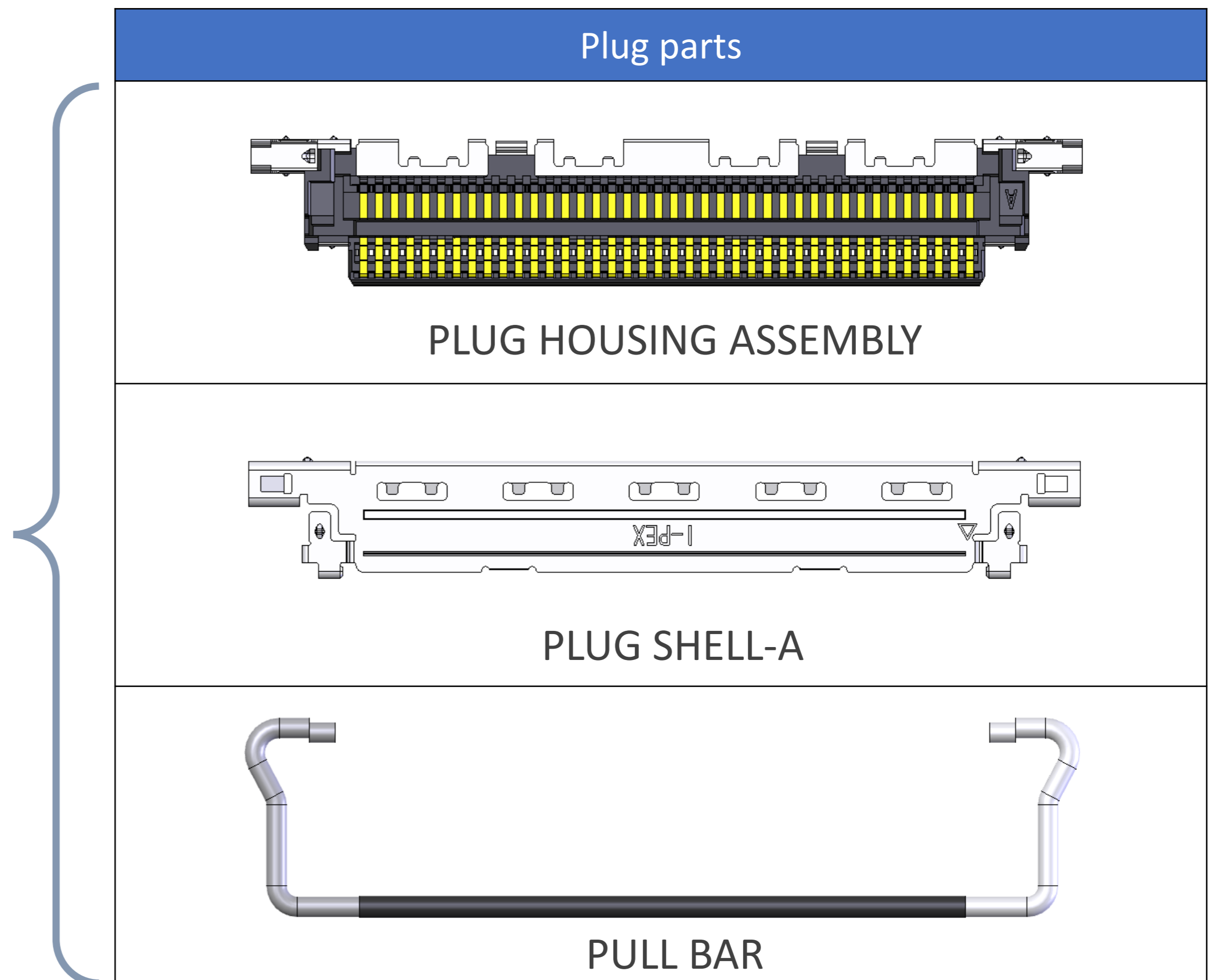
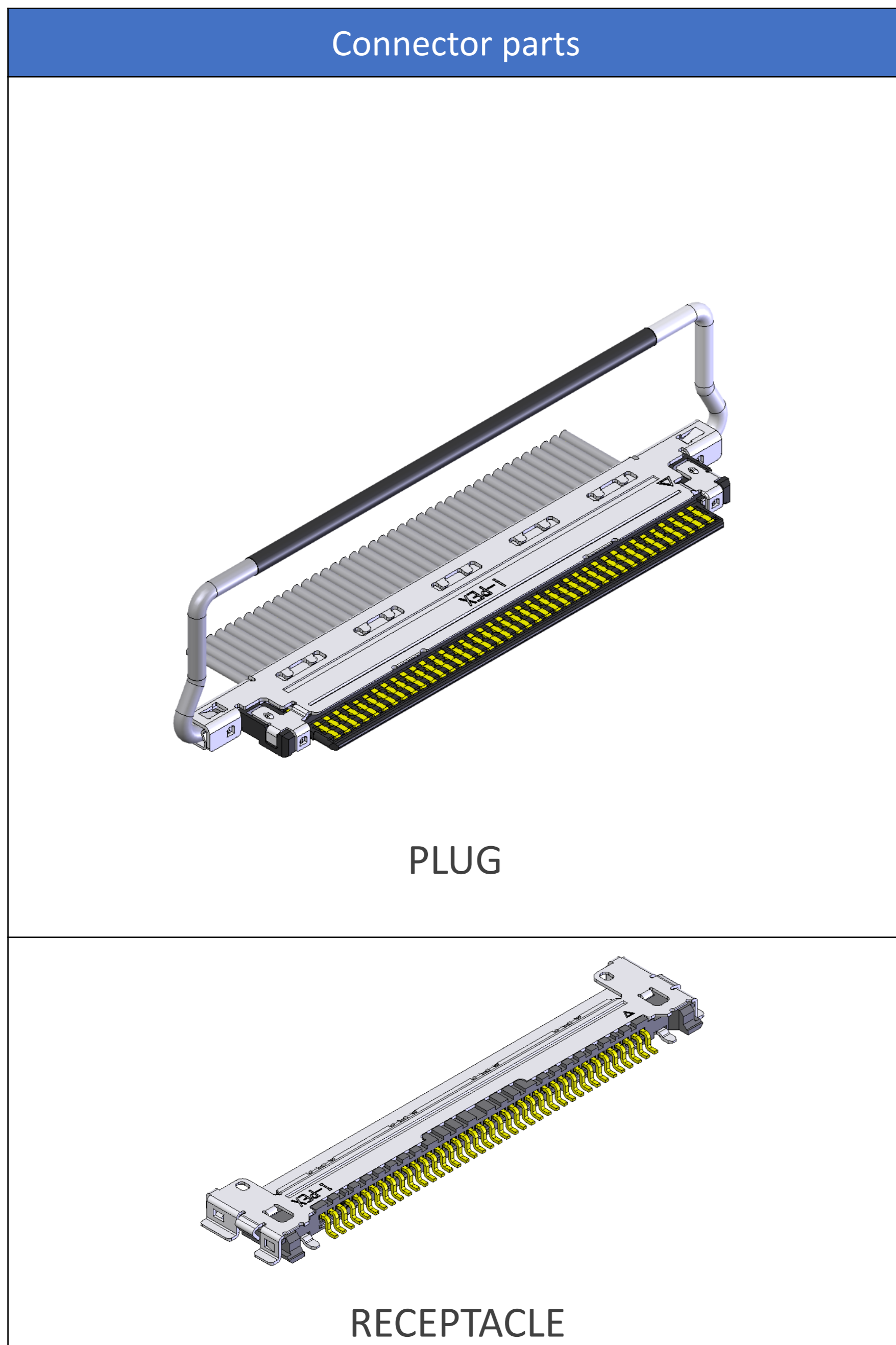

# Plug for Cable Assembly

Recommended P/N	20633-2**T-01S(12~60P)							20633-310T-01S(10P)
PART NO.	POS.	A	B	C	D	E	F	G
20633-#10T-01S	10	3.60	4.40	6.66	9.40	4.65	9.75	10.95
20633-#12T-01S	12	4.40	5.20	7.46	10.20	5.45	10.55	11.75
20633-#20T-01S	20	7.60	8.40	10.66	13.40	8.65	13.75	14.95
20633-#30T-01S	30	11.60	12.40	14.66	17.40	12.65	17.75	18.95
20633-#40T-01S	40	15.60	16.40	18.66	21.40	16.65	21.75	22.95
20633-#50T-01S	50	19.60	20.40	22.66	25.40	20.65	25.75	26.95
20633-#60T-01S	60	23.60	24.40	26.66	29.40	24.65	29.75	30.95

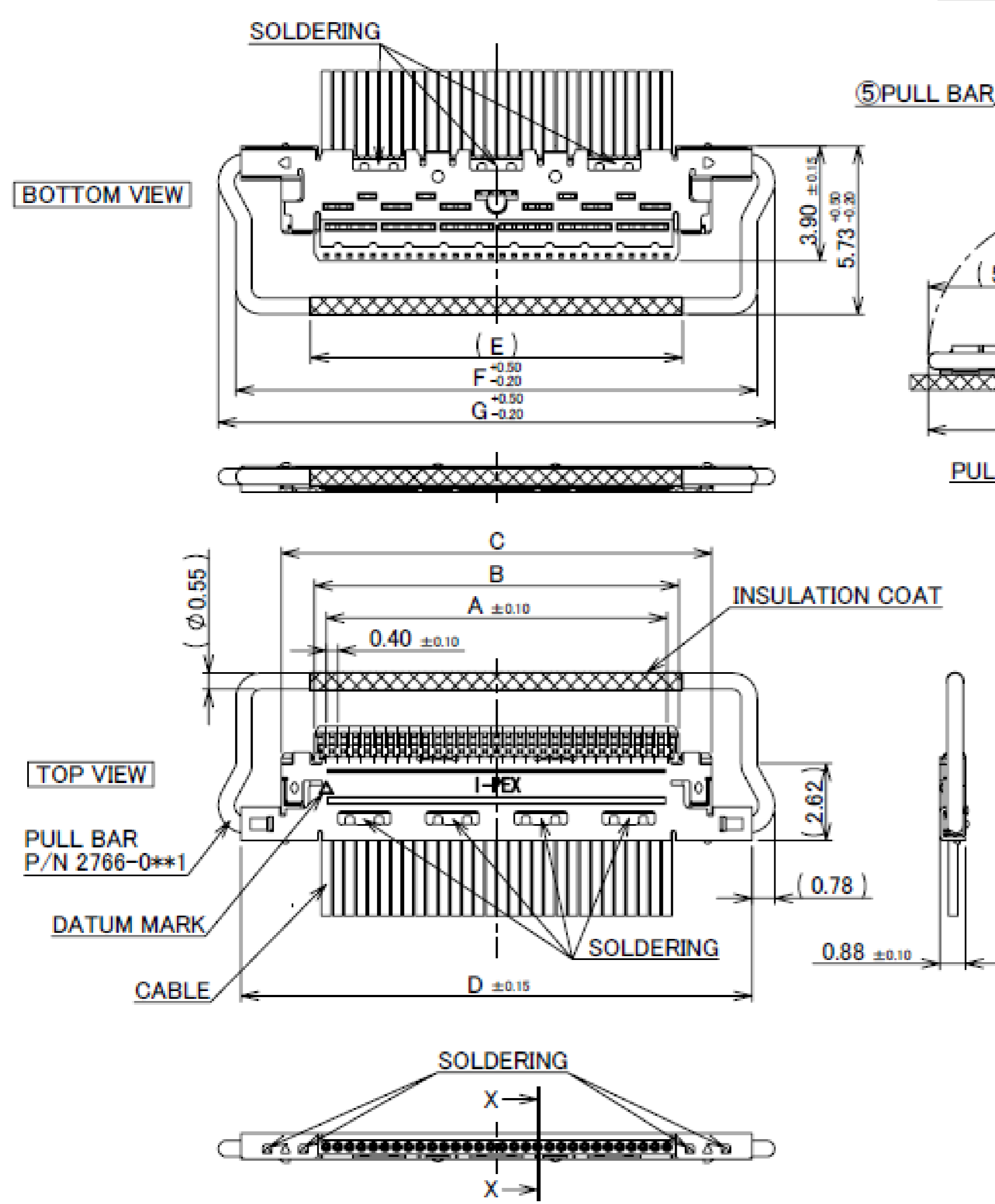

P/N : 20633- # \*\* T-0 # S

1 : WITH PULL BAR  
2 : WITHOUT PULL BAR  
Pos.  
SEE TABLE.1

**WITH PULL BAR** **HF** **RoHS**  
Halogen Free RoHS Compliant

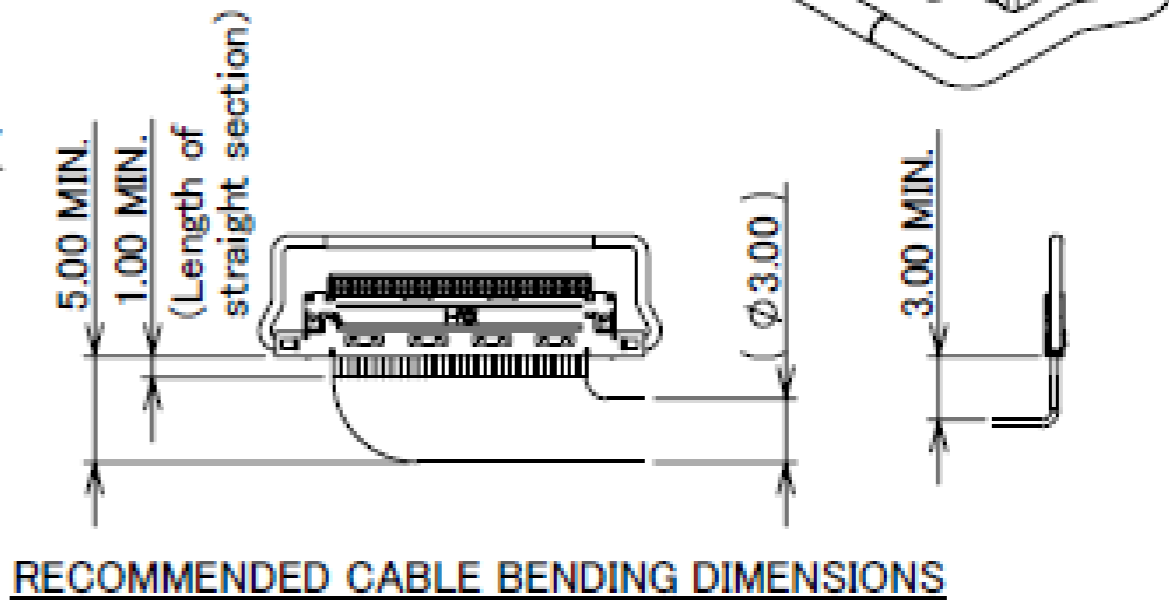
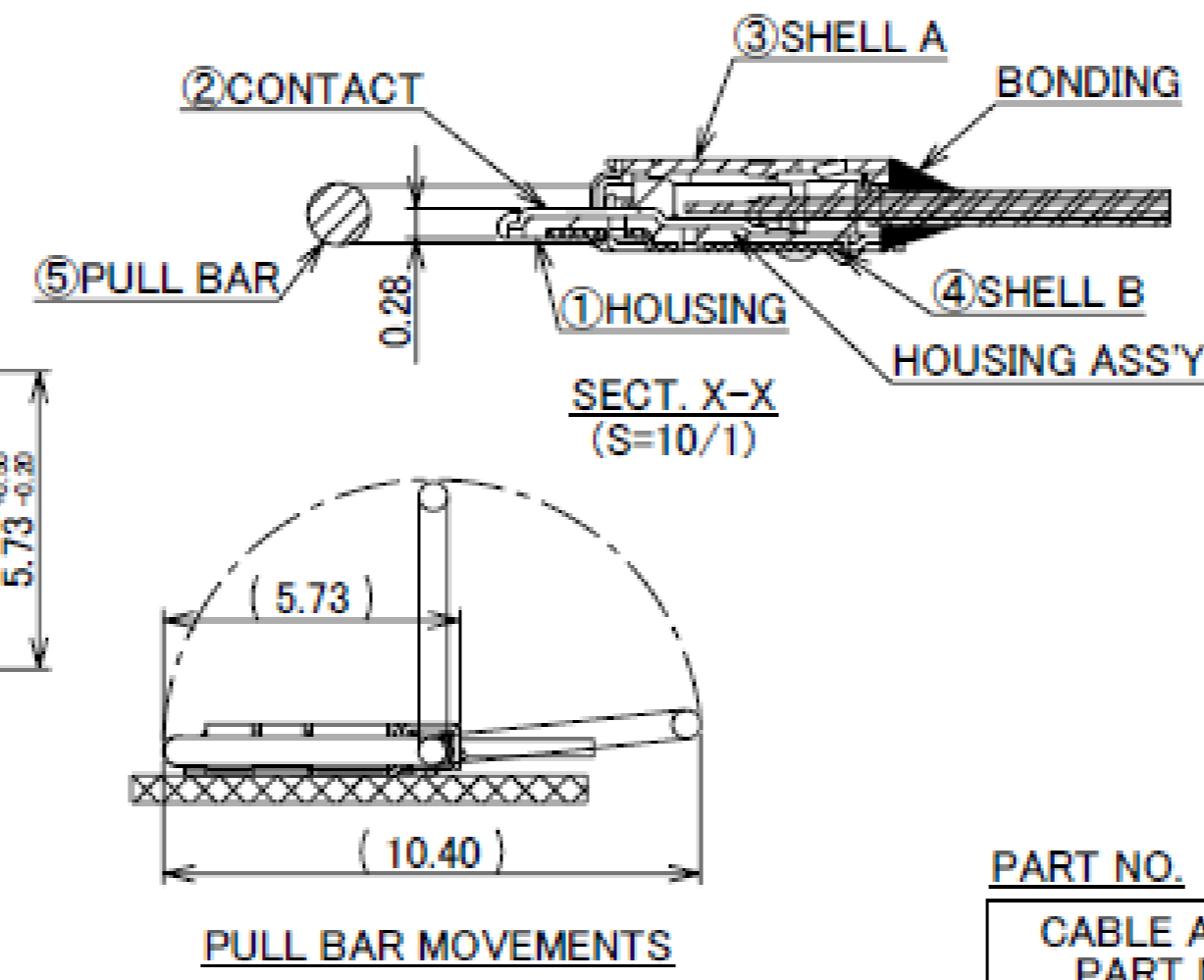

PART NO.	CABLE ASS'Y PART NO.	HOUSING ASS'Y PART NO.	SHELL A PART NO.	PULL BAR PART NO.
20633-2**T-01S	20634-1**T-02	2764-0**1-002		2766-0**1
20633-3**T-01S	20634-2**T-02	2764-0**1-003		

PART NO.	CONTACT FINISH	SHELL A FINISH	SHELL B FINISH
20633-2**T-0#S	<b>CONTACT AREA</b> Au 0.1 μm MIN. OVER Ni 1.00 μm MIN. <b>SOLDERING AREA</b> Au 0.05 μm MIN. OVER Ni 1.00 μm MIN.	<b>TOP SIDE</b> Au 0.03 μm MIN. OVER Ni 1.00 μm MIN. <b>BOTTOM SIDE</b> Ni 1.00 μm MIN.(THERE IS THE POSSIBILITY THAT Au ATTACHES RANDOMLY)	<b>TOP SIDE</b> Ni 1.00 μm MIN.(THERE IS THE POSSIBILITY THAT Au ATTACHES RANDOMLY) <b>BOTTOM SIDE</b> Au 0.03 μm MIN. OVER Ni 1.00 μm MIN.
20633-3**T-0#S	<b>CONTACT AREA</b> Au 0.03 μm MIN. OVER Ni 1.00 μm MIN. <b>SOLDERING AREA</b> Au 0.03 μm MIN. OVER Ni 1.00 μm MIN.	<b>PARTIAL Au 0.003 μm MIN. OVER Ni 1.00 μm MIN.</b>	<b>PARTIAL Au 0.003 μm MIN. OVER Ni 1.00 μm MIN.</b>

NO.	DISCRIPTION	MATERIAL	FINISH , REMARKS
5	PULL BAR	SUS	
4	SHELL B	PHOSPHOR BRONZE	SEE ABOVE TABLE.1
3	SHELL A	PHOSPHOR BRONZE	SEE ABOVE TABLE.1
2	CONTACT	PHOSPHOR BRONZE	SEE ABOVE TABLE.1
1	HOUSING	LCP	UL94V-0. BLACK

Rev.12

Recommended P/N	20633-2**T-01S(12~60P)				20633-310T-01S(10P)
PART NO.	POS.	A	B	C	D
20633-#10T-02S	10	3.60	4.40	6.66	9.40
20633-#12T-02S	12	4.40	5.20	7.46	10.20
20633-#20T-02S	20	7.60	8.40	10.66	13.40
20633-#30T-02S	30	11.60	12.40	14.66	17.40
20633-#40T-02S	40	15.60	16.40	18.66	21.40
20633-#50T-02S	50	19.60	20.40	22.66	25.40
20633-#60T-02S	60	23.60	24.40	26.66	29.40

P/N : 20633- # \*\* T-0 # S

1 : WITH PULL BAR  
2 : WITHOUT PULL BAR  
Pos.  
SEE TABLE.1 (SHEET1/5)

**WITHOUT PULL BAR**

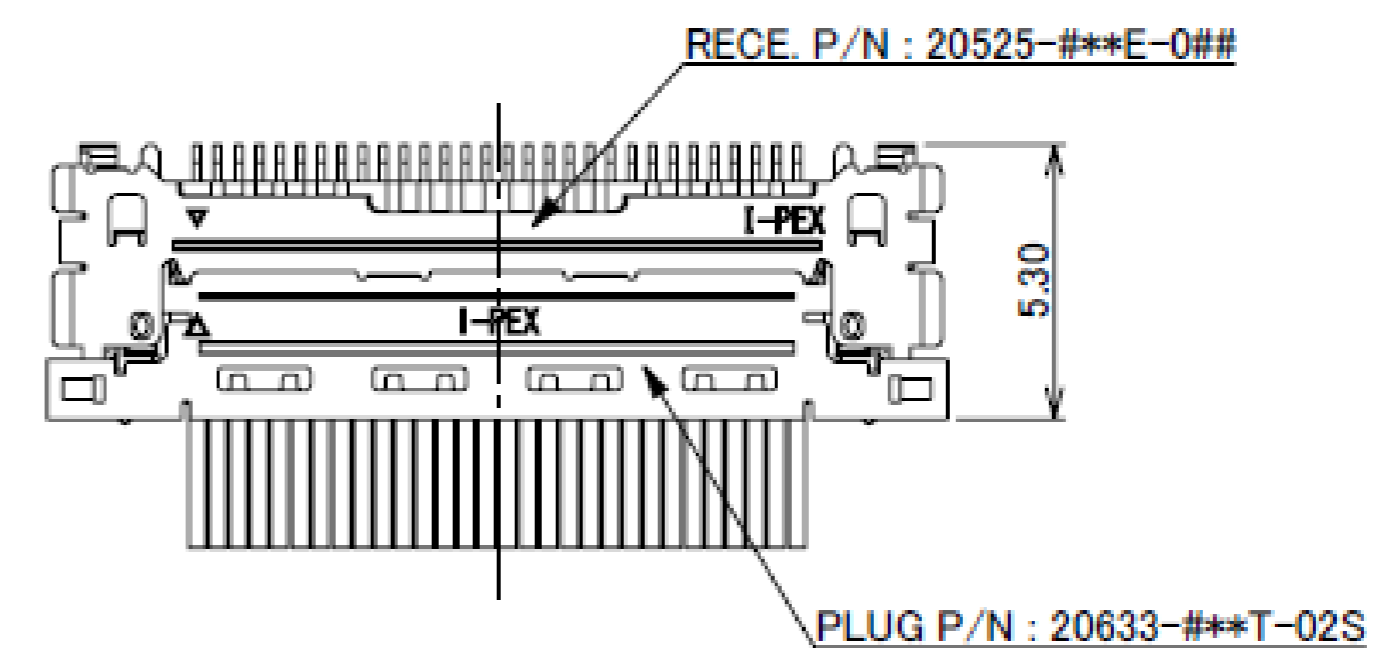
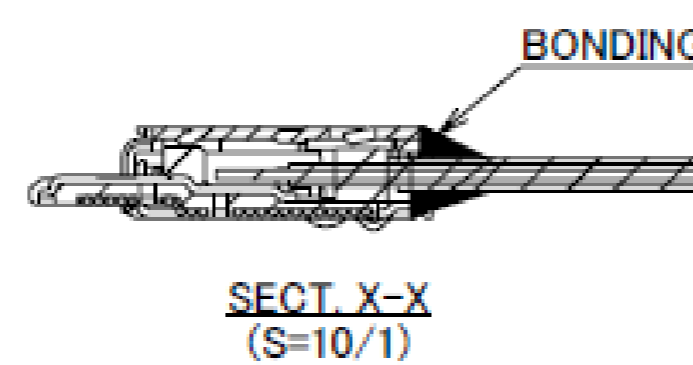
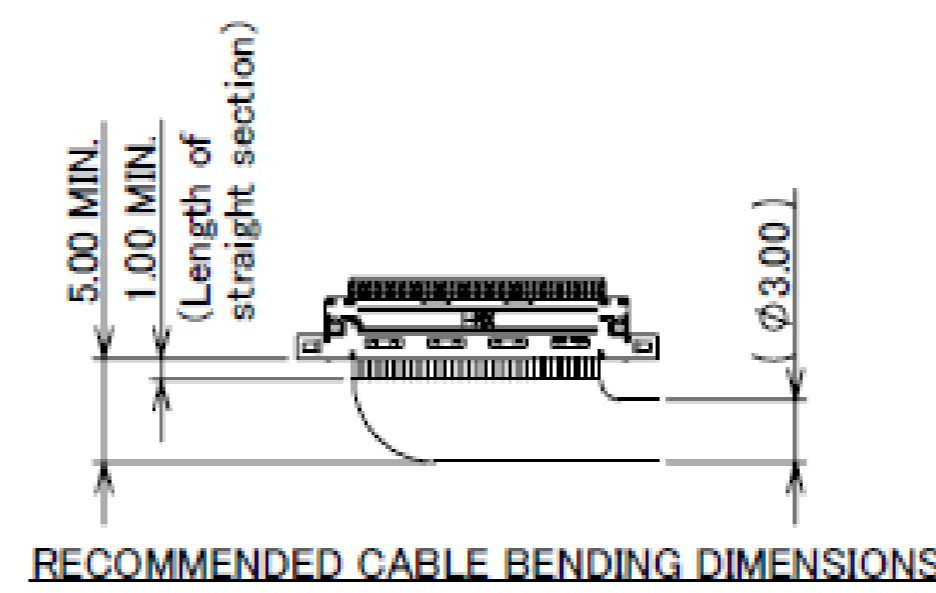
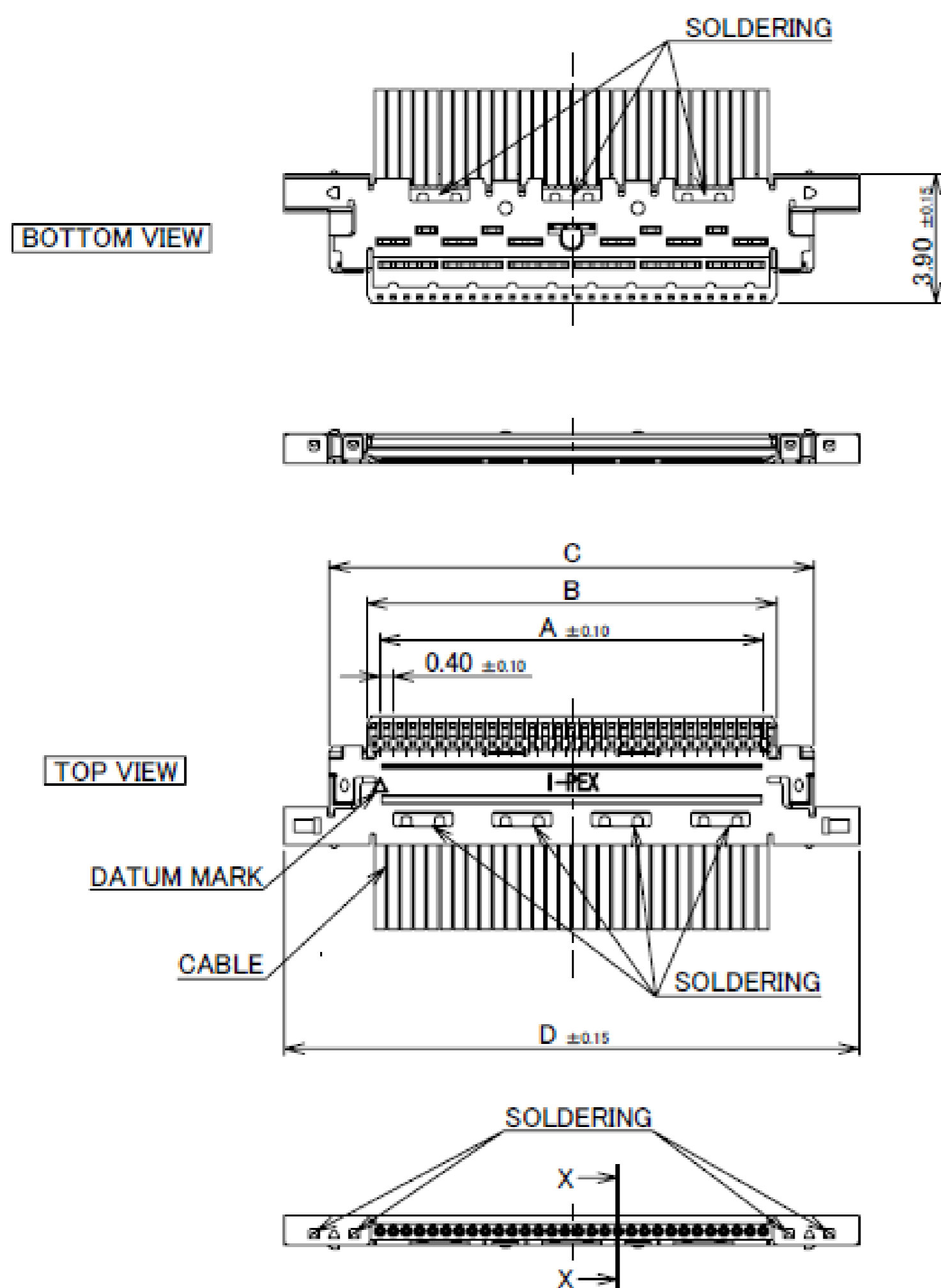

PART NO.	CABLE ASS'Y PART NO.	HOUSING ASS'Y PART NO.	SHELL-A PART NO.	PULL BAR PART NO.
20633-2**T-02S	20634-1**T-02	2764-0**1-002		-
20633-3**T-02S	20634-2**T-02	2764-0**1-003		

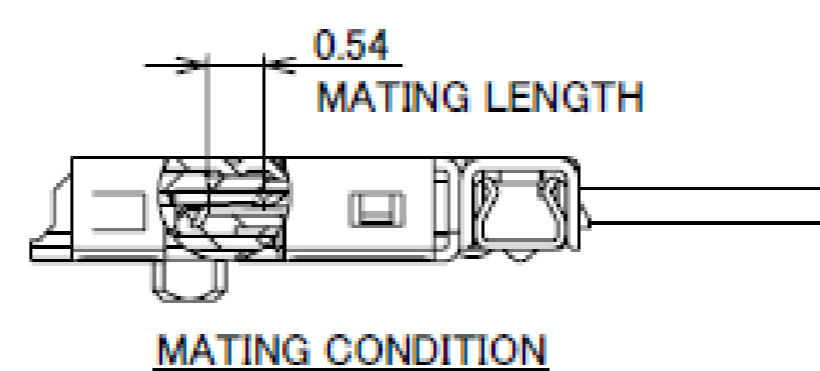

Rev.12

# Plug for Cable Assembly

PART NO.	POS.	A
20633-#10T-0#S	10	3.60
20633-#12T-0#S	12	4.40
20633-#20T-0#S	20	7.60
20633-#30T-0#S	30	11.60
20633-#40T-0#S	40	15.60
20633-#50T-0#S	50	19.60
20633-#60T-0#S	60	23.60

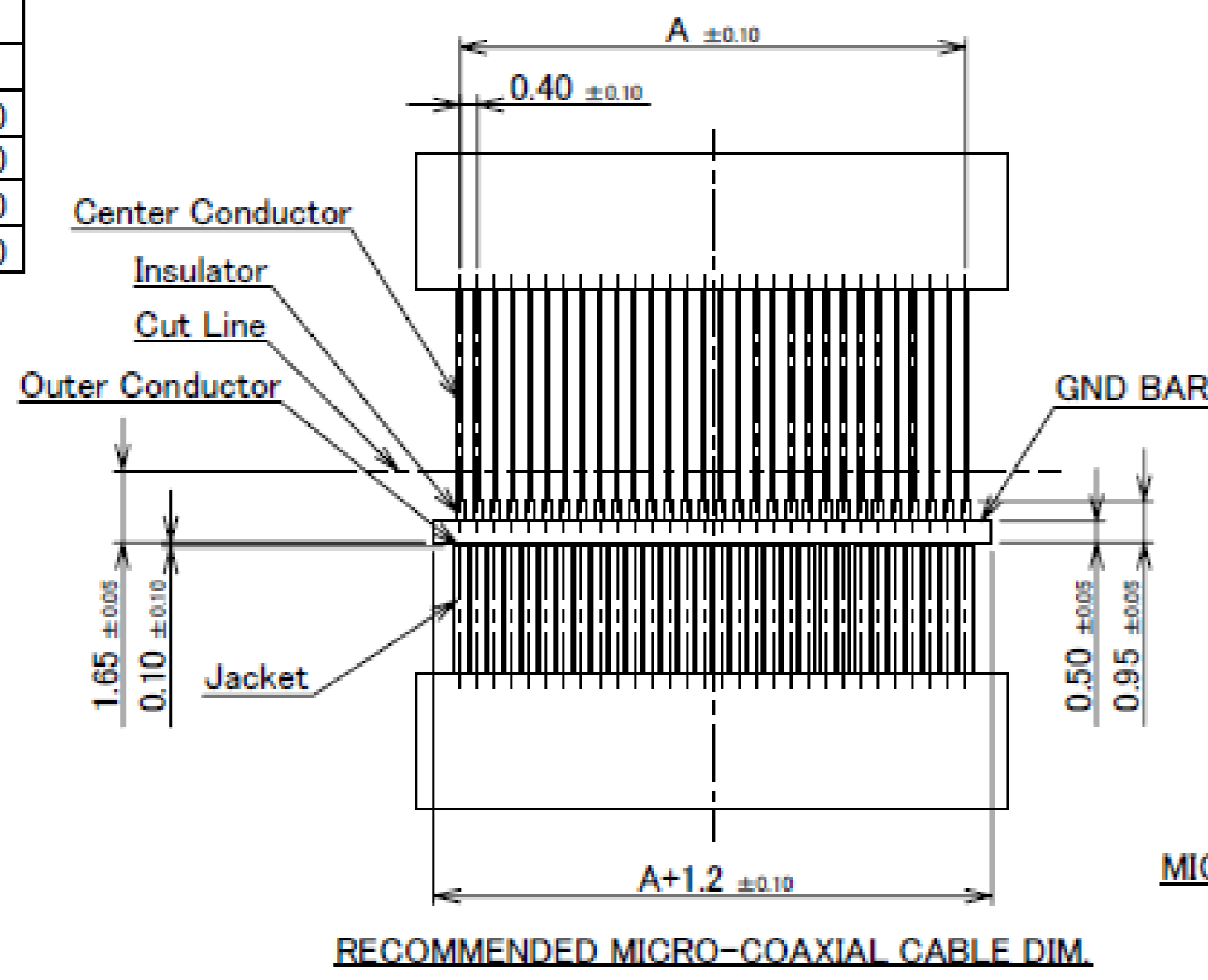

## CHARACTERISTIC IMPEDANCE MATCHING MICRO-COAXIAL CABLE

	a
#38	0.12
#40	0.09
#42	0.075
#44	0.063

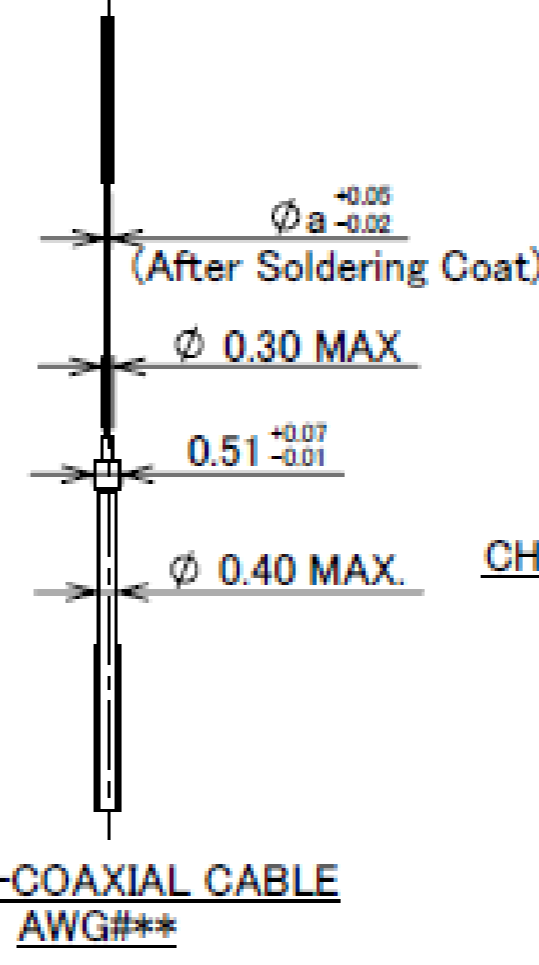

## CHARACTERISTIC IMPEDANCE UN-MATCHING MICRO-COAXIAL CABLE

	a
#36	0.15

MICRO-COAXIAL CABLE #36 : NOT RECOMMENDED FOR HIGH SPEED SIGNAL TRANSFER

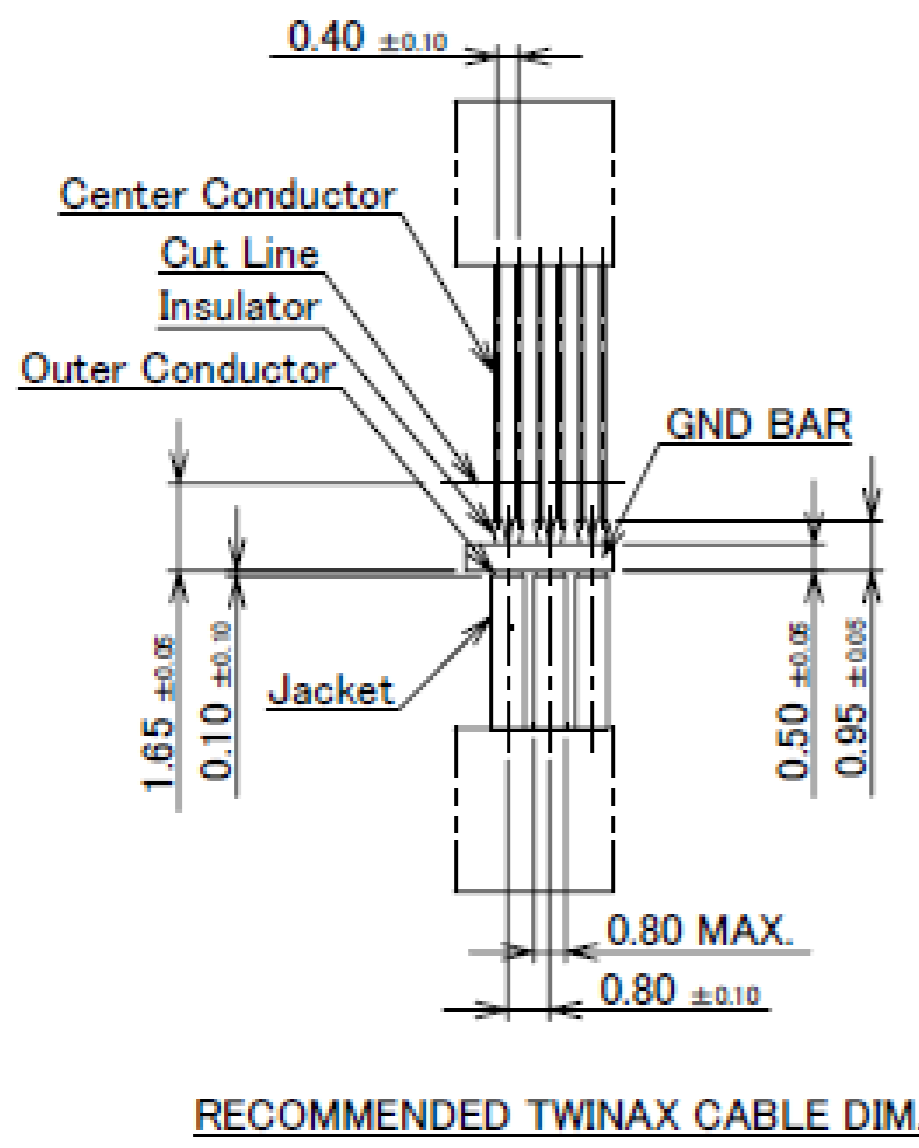

## TWINAX CABLE DIMENSION

	b
#40	0.09
#42	0.075

**TWINAX CABLE**  
AWG#\*\*

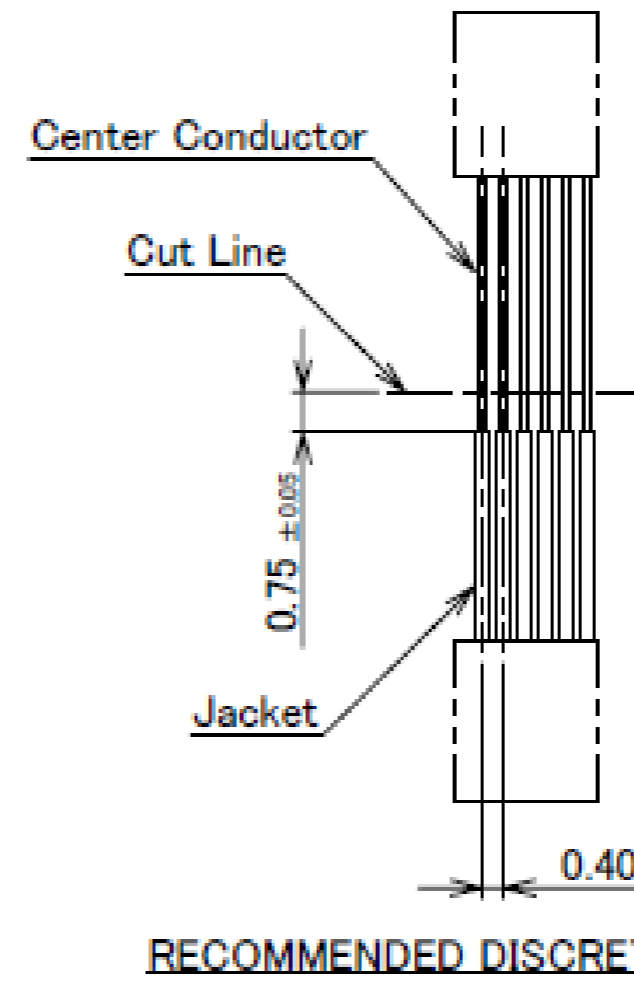

## DISCRETE WIRE DIMENSION

	c
#34	0.192
#36	0.15

**DISCRETE WIRE**  
AWG#\*\*

Rev.12

PART NO.
20633-##T-0#S

## THE EXTERNAL APPEARANCE

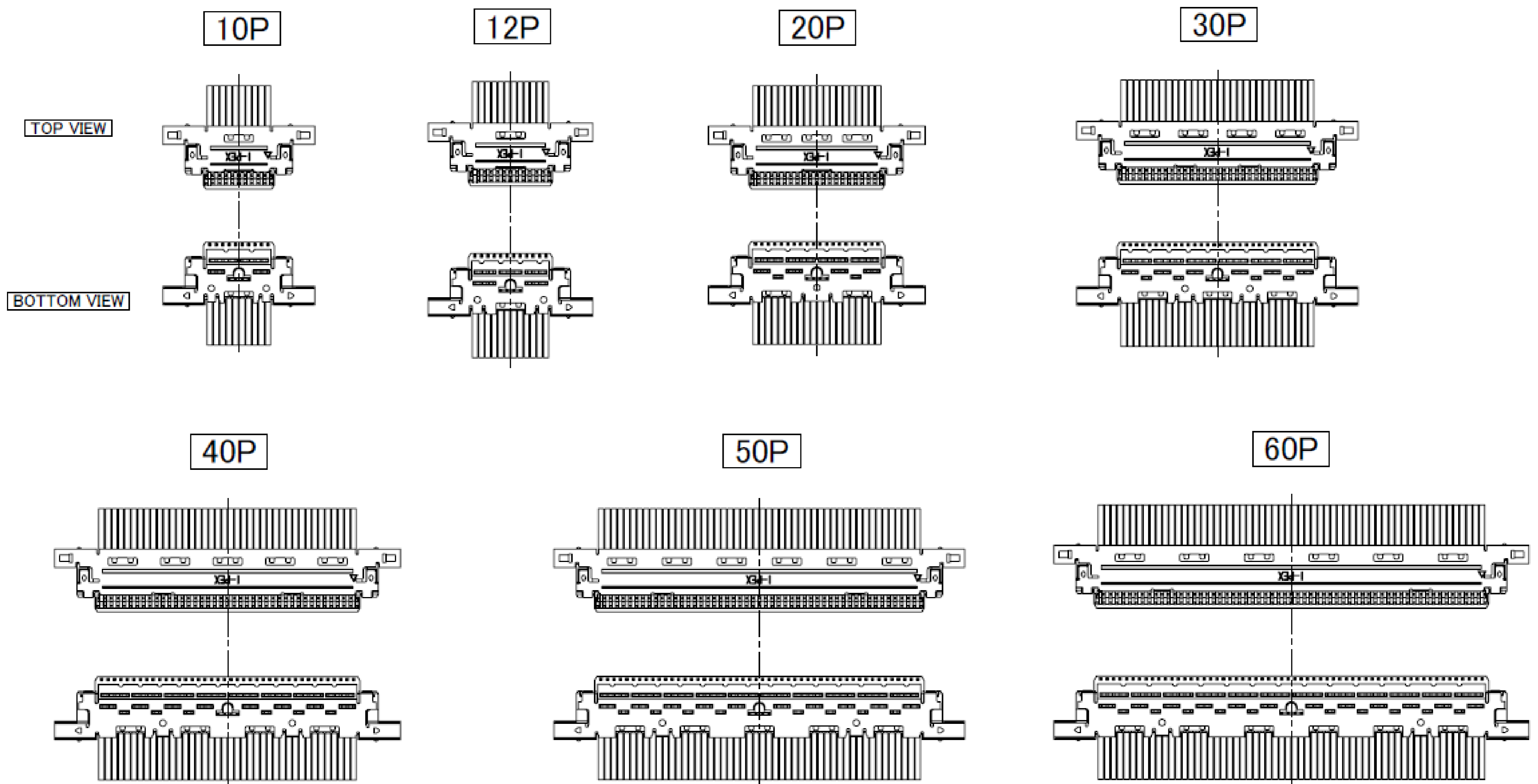

Rev.12

# Plug Housing Assembly

Recommended P/N	20634-1**T-02(12~60P)						20634-210T-02(10P)				
PART NO.	Pos.	A	B	C	D	E	F	G	H	J	K
20634-#10T-02	10	5.10	4.65	4.30	3.60	4.40	6.66	9.40	3.40	-	-
20634-#12T-02	12	5.90	5.45	5.10	4.40	5.20	7.46	10.20	4.10	-	-
20634-#20T-02	20	9.10	8.65	8.30	7.60	8.40	10.66	13.40	-	5.00	-
20634-#30T-02	30	13.10	12.65	12.30	11.60	12.40	14.66	17.40	4.00	8.00	4.00
20634-#40T-02	40	17.10	16.65	16.30	15.60	16.40	18.66	21.40	8.00	12.00	4.00
20634-#50T-02	50	21.10	20.65	20.30	19.60	20.40	22.66	25.40	12.00	16.00	4.00
20634-#60T-02	60	25.10	24.65	24.30	23.60	24.40	26.66	29.40	16.00	20.00	4.00

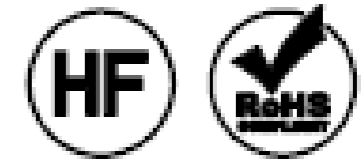

P/N: 20634-#\*\*T-02  
 ↳ POS.  
 ↳ SEE TABLE.1

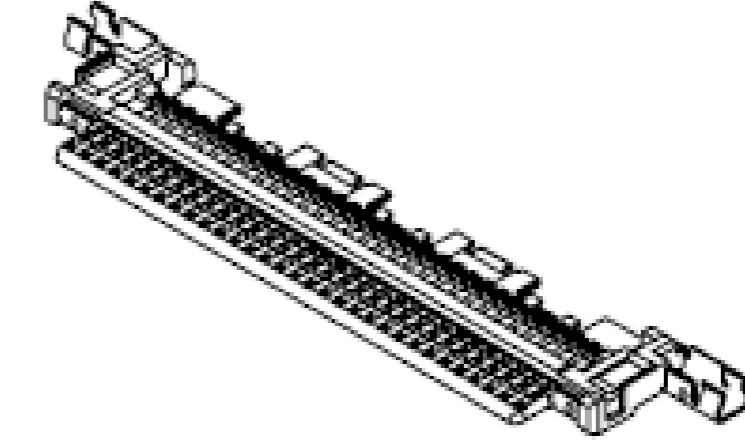
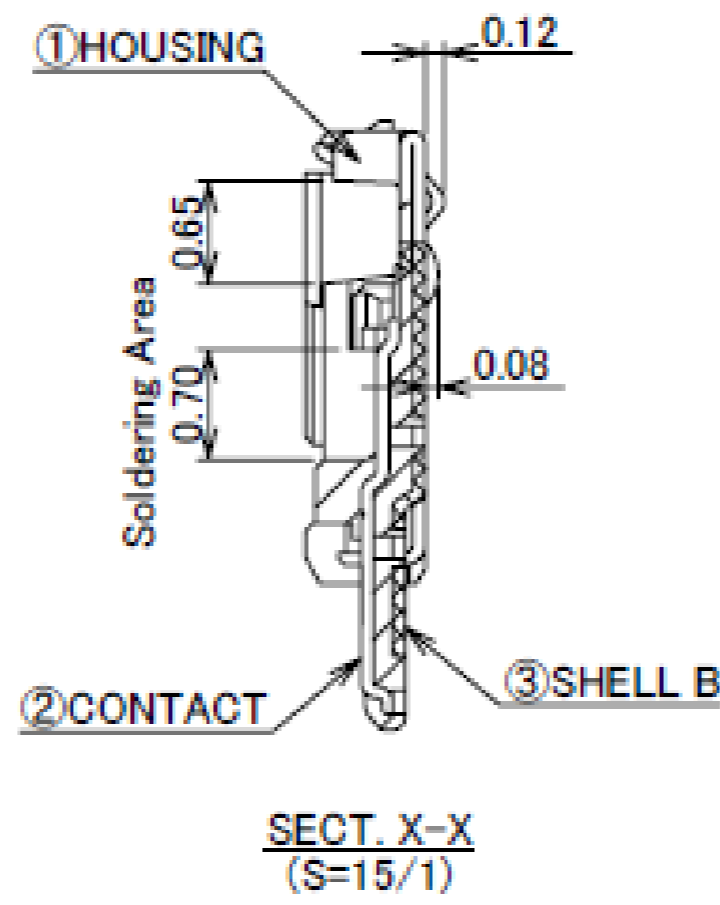
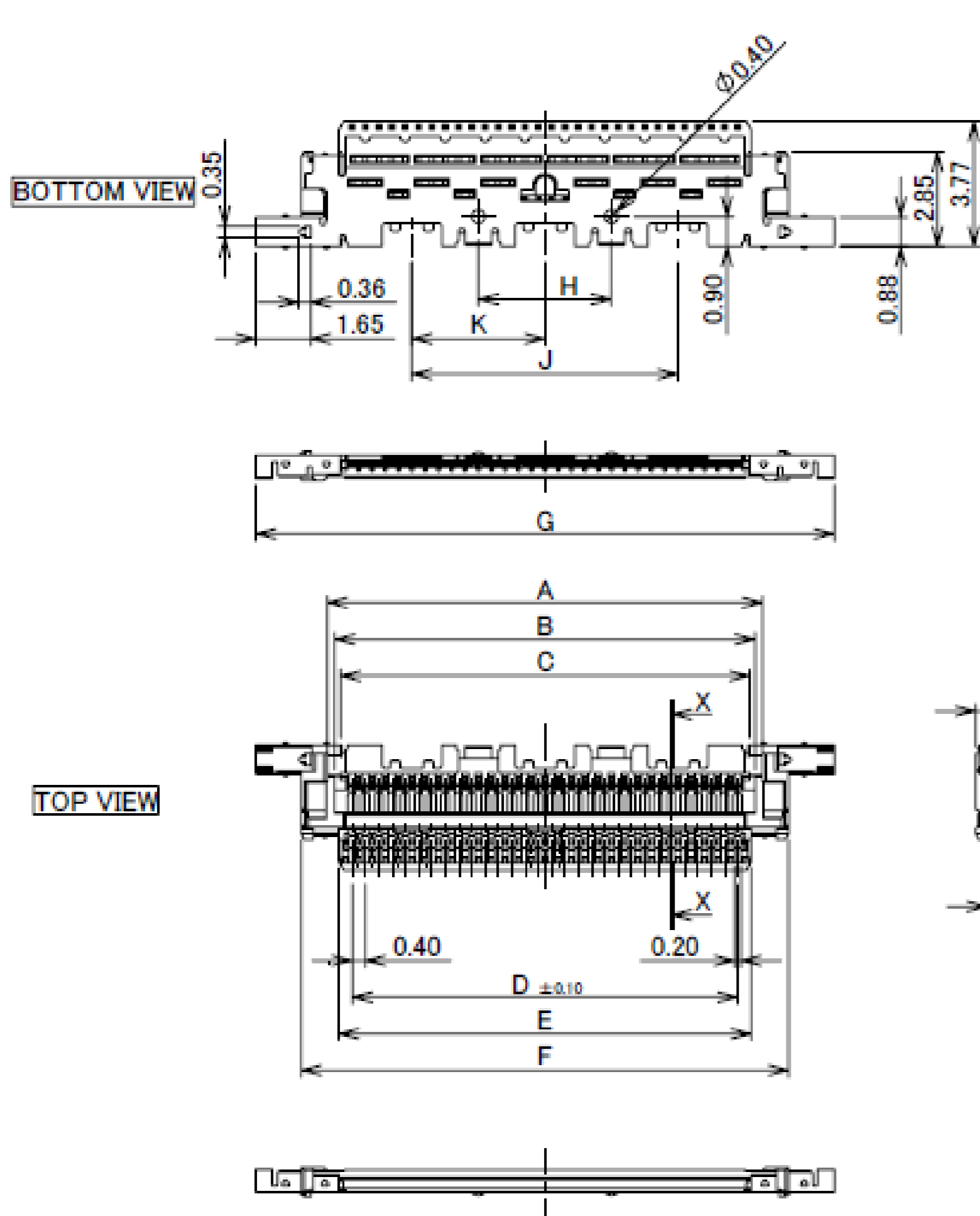

NOTES  
 1. THIS PART IS ASSEMBLED WITH SHELL A(P/N 2764-0\*\*1-00#)  
 AND PULL BAR(P/N 2766-0\*\*1) AFTER SOLDERED THE CABLE,  
 AND IT BECOMES P/N 20633-#\*\*T-0#S

PART NO.	CONTACT FINISH	SHELL B FINISH
20634-1**T-02	CONTACT AREA Au 0.1 μm MIN. OVER Ni 1.00 μm MIN. SOLDERING AREA Au 0.05 μm MIN. OVER Ni 1.00 μm MIN.	TOP SIDE Ni 1.00 μm MIN.(THERE IS THE POSSIBILITY THAT Au ATTACHES RANDOMLY) BOTTOM SIDE Au 0.03 μm MIN. OVER Ni 1.00 μm MIN.
20634-2**T-02	CONTACT AREA Au 0.03 μm MIN. OVER Ni 1.00 μm MIN. SOLDERING AREA Au 0.03 μm MIN. OVER Ni 1.00 μm MIN.	PARTIAL Au 0.003 μm MIN. OVER Ni 1.00 μm MIN.

NO.	DISCRIPTION	MATERIAL	FINISH , REMARKS
3	SHELL-B	PHOSPHOR BRONZE	SEE ABOVE TABLE.1
2	CONTACT	PHOSPHOR BRONZE	SEE ABOVE TABLE.1
1	HOUSING	LCP	UL94V-0, BLACK

Rev.11

# Plug Shell-A

Recommended P/N	2764-0**1-002(12~60P)				2764-0101-003(10P)
PART NO.	A	B	C	D	E
2764-0101-00#	9.40	3.88	6.66	-	-
2764-0121-00#	10.20	4.68	7.46	-	-
2764-0201-00#	13.40	7.88	10.66	2.50	5.00 [= 2.50 × (3 - 1)]
2764-0301-00#	17.40	11.88	14.66	3.00	9.00 [= 3.00 × (4 - 1)]
2764-0401-00#	21.40	15.88	18.66	3.25	13.00 [= 3.25 × (5 - 1)]
2764-0501-00#	25.40	19.88	22.66	3.40	17.00 [= 3.40 × (6 - 1)]
2764-0601-00#	29.40	23.88	26.66	4.00	20.00 [= 4.00 × (6 - 1)]

P/N: 2764-0\*\*1-00#  
 ↳ POS.  
 ↳ SEE TABLE.1

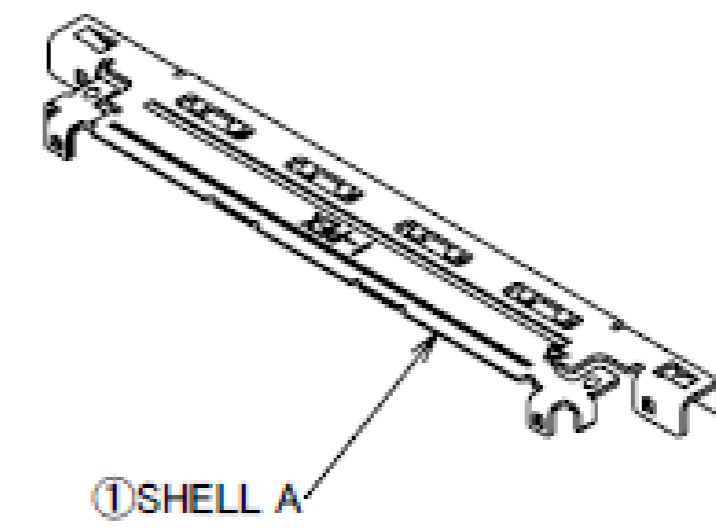
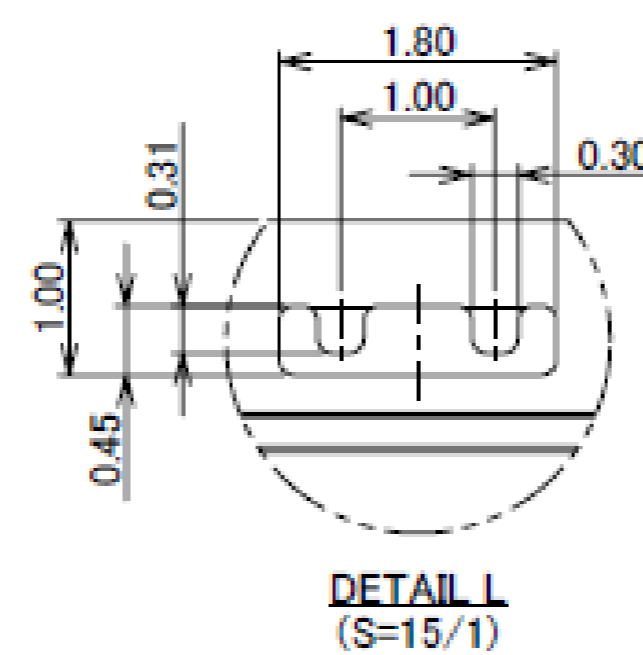
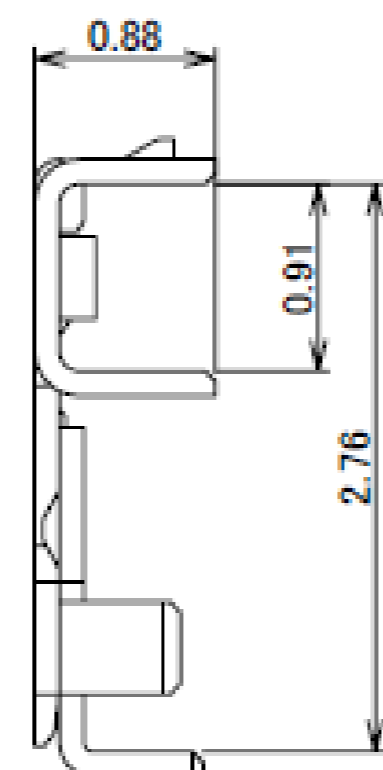
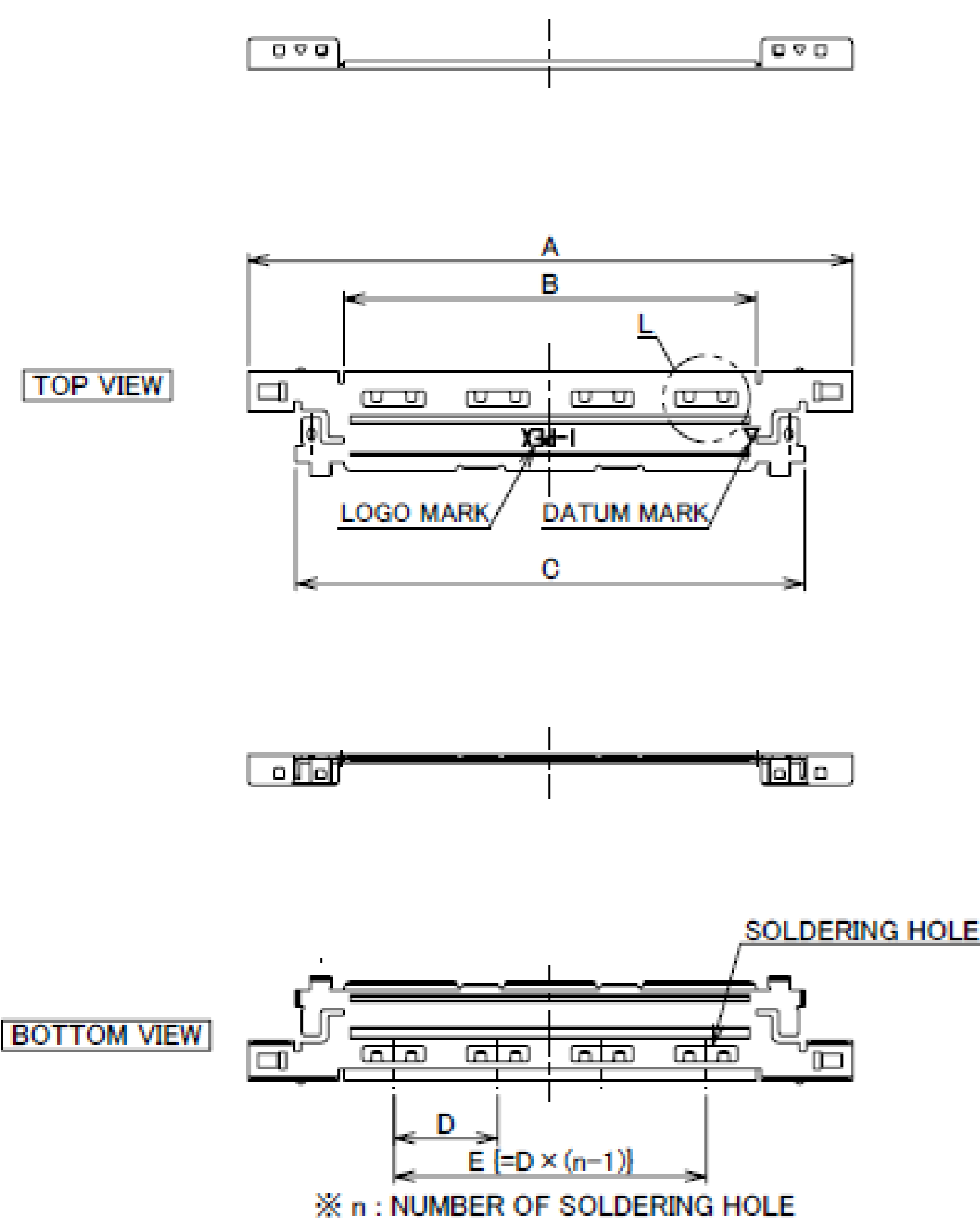
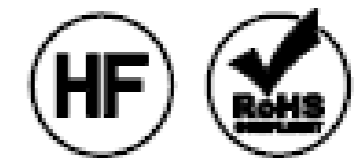

PART NO.	SHELL A FINISH
2764-0**1-002	TOP SIDE Au 0.03 μm MIN. OVER Ni 1.00 μm MIN. BOTTOM SIDE Ni 1.00 μm MIN.(THERE IS THE POSSIBILITY THAT Au ATTACHES RANDOMLY)
2764-0**1-003	PARTIAL Au 0.003 μm MIN. OVER Ni 1.00 μm MIN.

NO.	DISCRIPTION	MATERIAL	FINISH , REMARKS
1	SHELL A	PHOSPHOR BRONZE	SEE ABOVE TABLE.1

Rev.11

# Plug Pull Bar

Recommended P/N			2766-0**1	
PART NO.	A	B		
2766-0101	8.65	9.85		
2766-0121	9.45	10.65		
2766-0201	12.65	13.85		
2766-0301	16.65	17.85		
2766-0401	20.65	21.85		
2766-0501	24.65	25.85		
2766-0601	28.65	29.85		

P/N: 2766-0\*\*1  
POS.

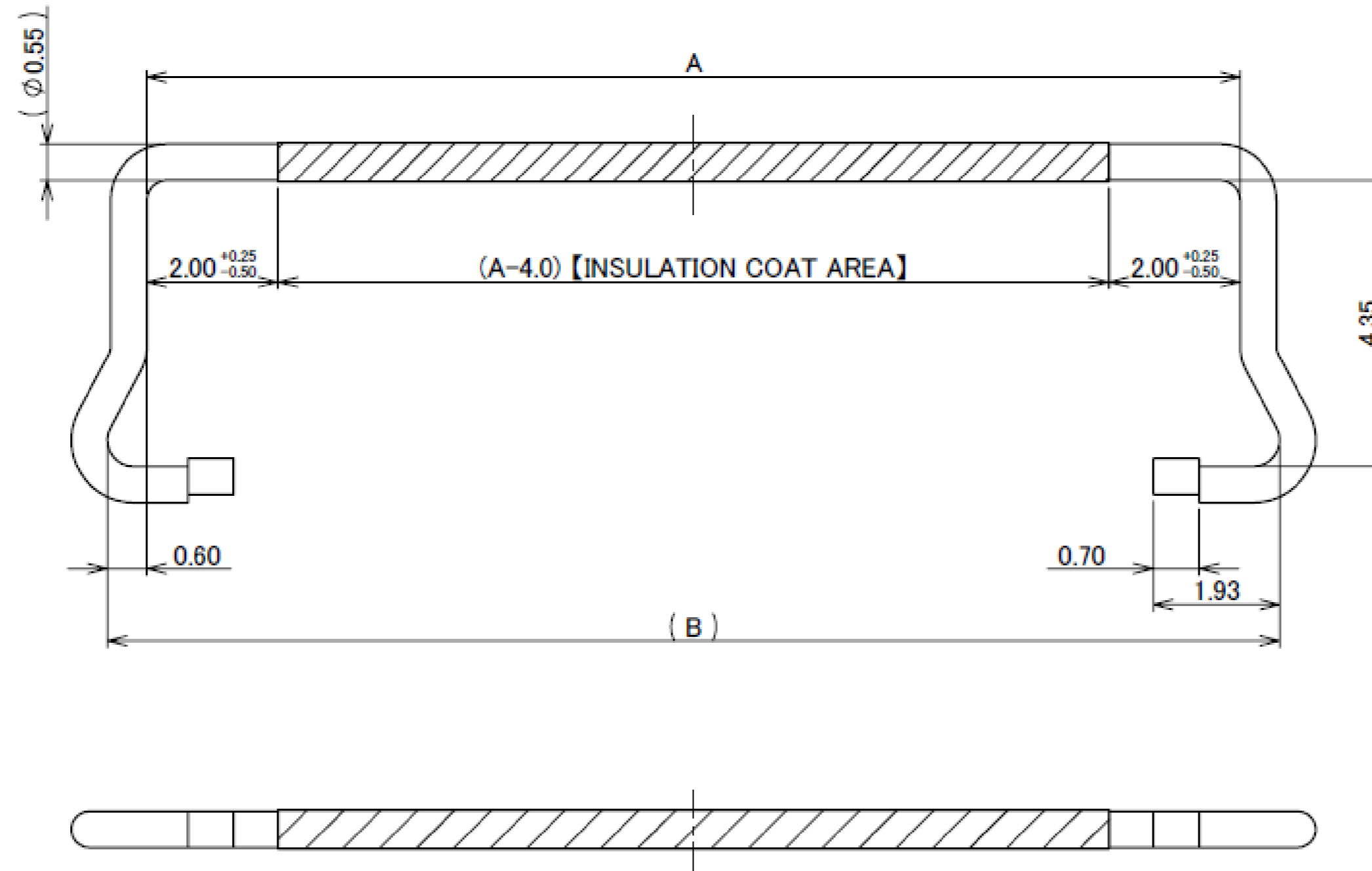

NO.	DISCRIPTION	MATERIAL	FINISH , REMARKS
1	PULL BAR	SUS	

Rev.14

# Receptacle Assembly

Recommended P/N		20525-0**E-02(12~60P)					20525-210E-02(10P)	
PART NO.	POS.	A	B	C	D	F		
20525-#10E-02	10	5.40	3.60	8.43	9.20	4.30		
20525-#12E-02	12	6.20	4.40	9.23	10.00	5.10		
20525-#20E-02	20	9.40	7.60	12.43	13.20	8.30		
20525-#30E-02	30	13.40	11.60	16.43	17.20	12.30		
20525-#40E-02	40	17.40	15.60	20.43	21.20	16.30		
20525-#50E-02	50	21.40	19.60	24.43	25.20	20.30		
20525-#60E-02	60	25.40	23.60	28.43	29.20	24.30		

P/N: 20525-#\*\*E-02  
POS. SEE TABLE 1

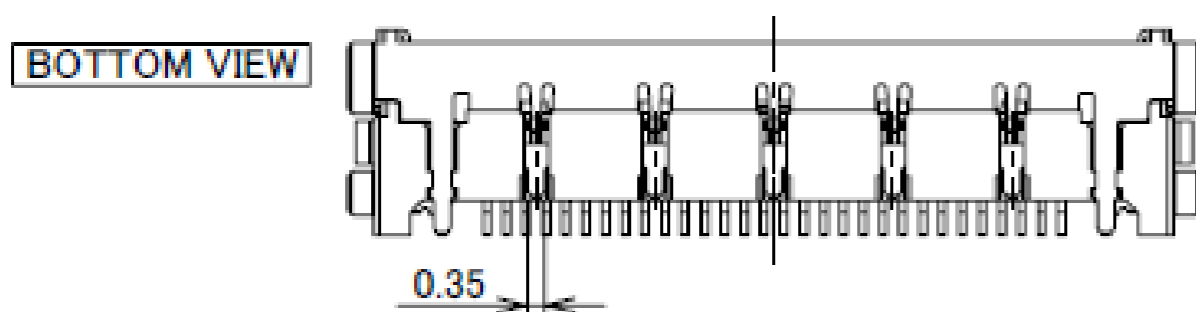
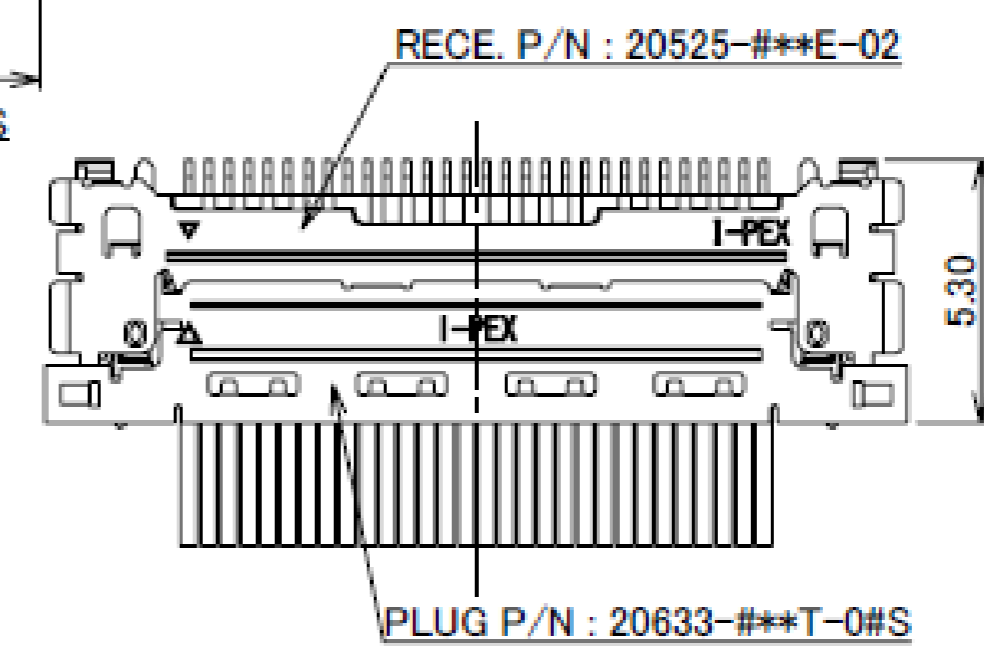
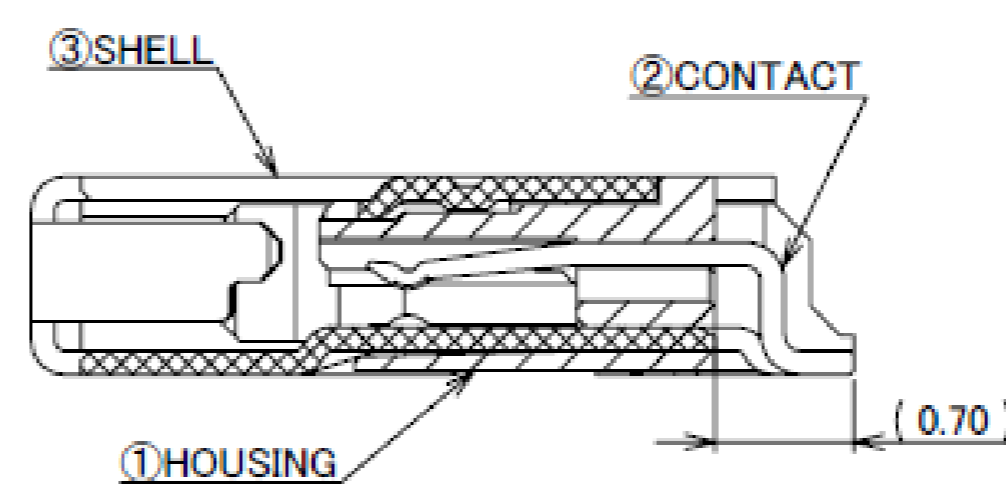
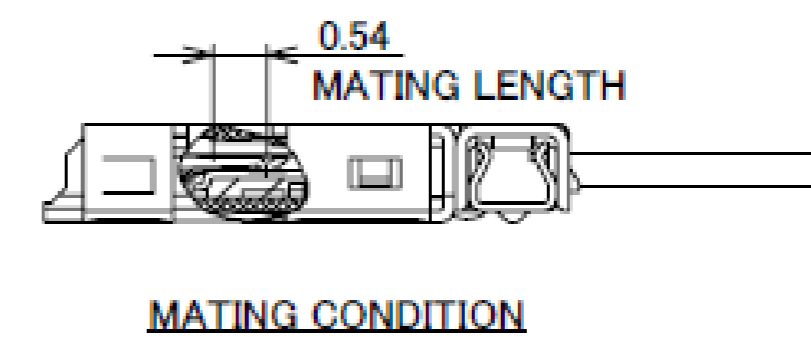
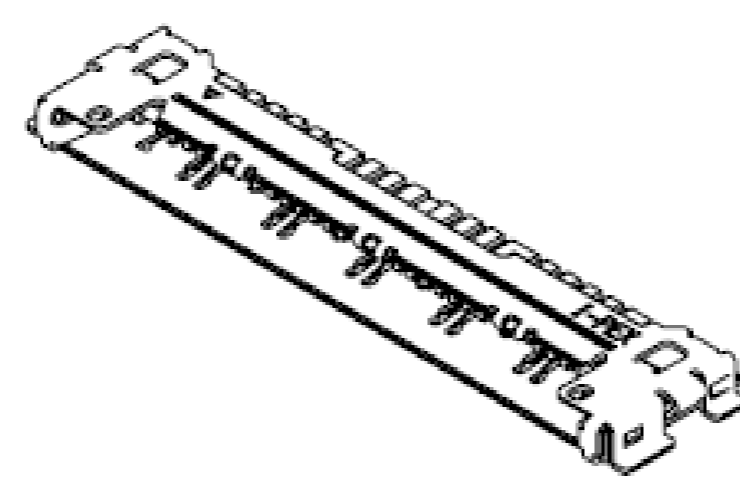
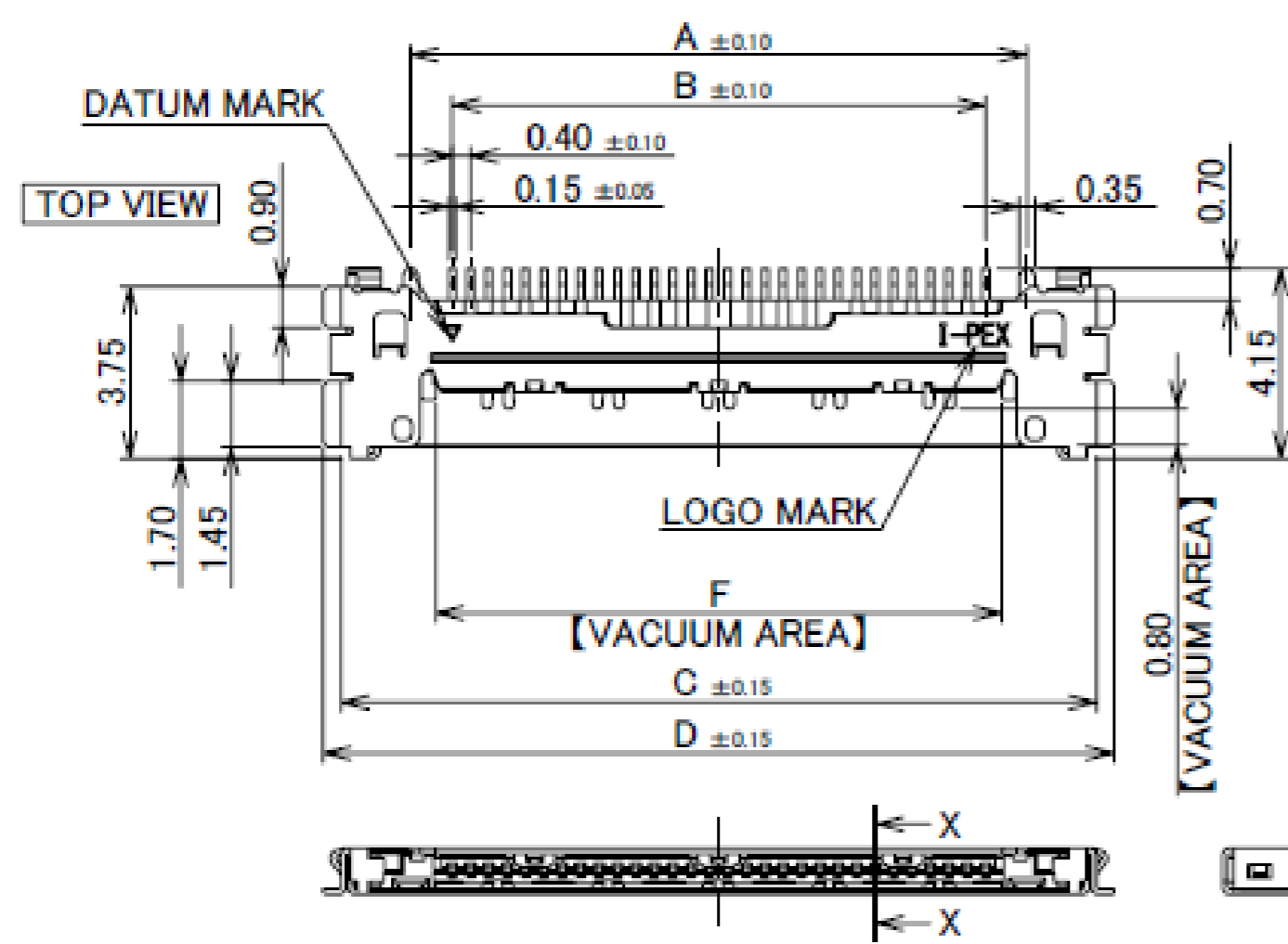
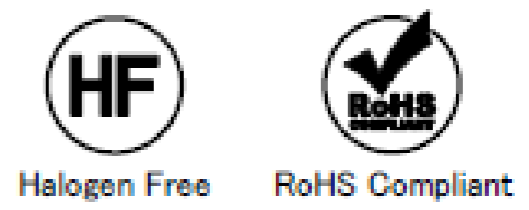

TABLE 1

PART NO.	CONTACT FINISH	SHELL FINISH
20525-0**E-02	CONTACT AREA : Au 0.1 μm MIN. OVER Ni 1.00 μm MIN. SOLDERING AREA : Au 0.03 μm MIN. OVER Ni 1.00 μm MIN.	ALL OVER Au 0.02 μm MIN. OVER Ni 1.00 μm MIN. CONTACT AREA : Au 0.02 μm MIN. OVER Ni 0.80 μm MIN.
20525-2**E-02	CONTACT AREA : Au 0.03 μm MIN. OVER Ni 1.00 μm MIN. SOLDERING AREA : Au 0.03 μm MIN. OVER Ni 1.00 μm MIN.	ALL OVER Ni 1.00 μm MIN. SOLDERING AREA : Au 0.02 μm MIN.

NO.	DISCRIPTION	MATERIAL	FINISH , REMARKS
3	SHELL	PHOSPHOR BRONZE	SEE TABLE 1
2	CONTACT	PHOSPHOR BRONZE	SEE TABLE 1
1	HOUSING	LCP	UL94V-0, BLACK

Rev.28

# Receptacle Assembly

PART NO.  
20525-##\*E-02

## BOTTOM VIEW

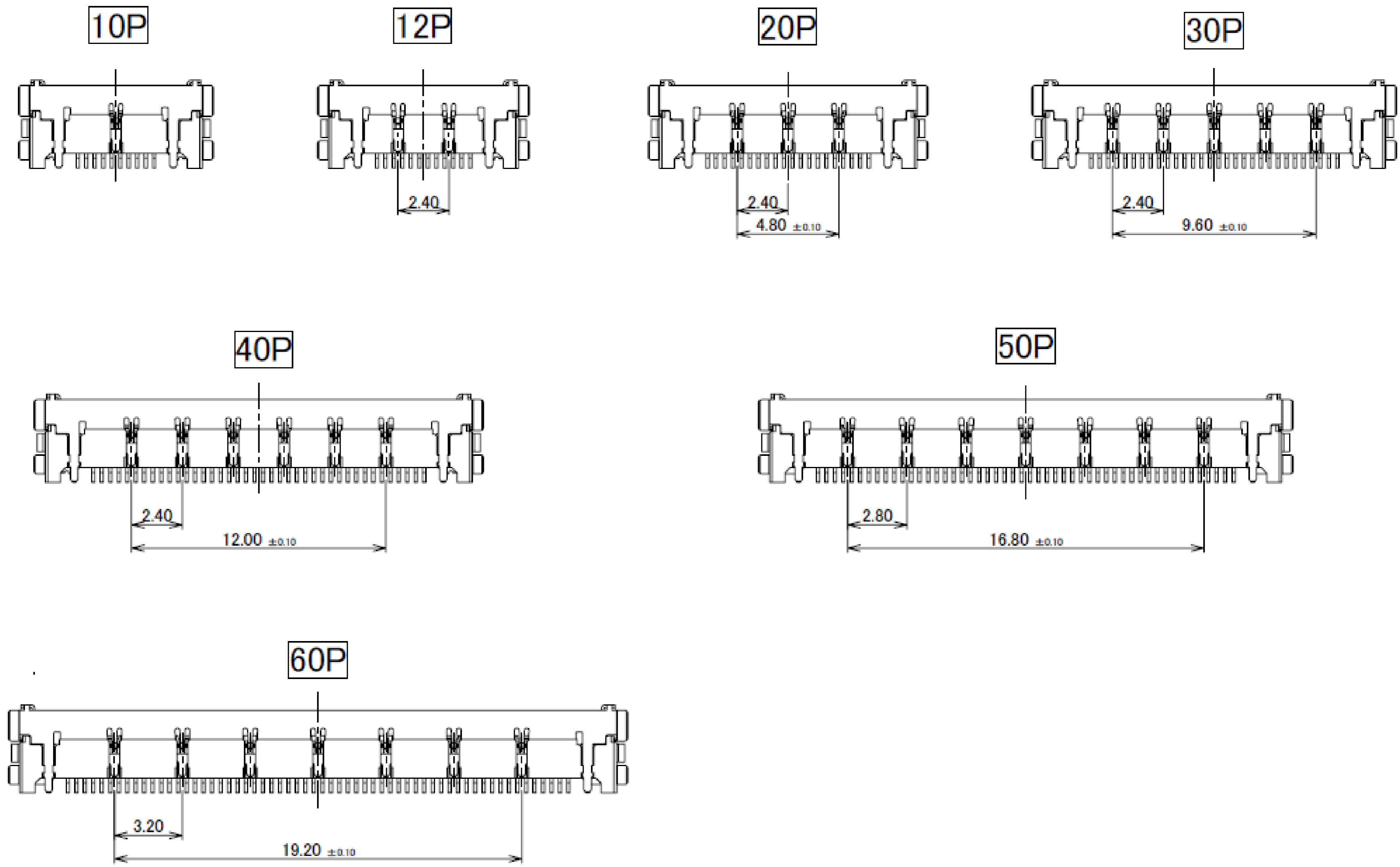

Rev.28

PART NO.	POS.	A	B	E	G	H	J	K
20525-#10E-02	10	5.40	3.60	-	8.18	9.60	11.60	-
20525-#12E-02	12	6.20	4.40	2.40	8.98	10.40	12.40	-
20525-#20E-02	20	9.40	7.60	4.80	12.18	13.60	15.60	2.40
20525-#30E-02	30	13.40	11.60	9.60	16.18	17.60	19.60	2.40
20525-#40E-02	40	17.40	15.60	12.00	20.18	21.60	23.60	2.40
20525-#50E-02	50	21.40	19.60	16.80	24.18	25.60	27.60	2.80
20525-#60E-02	60	25.40	23.60	19.20	28.18	29.60	31.60	3.20

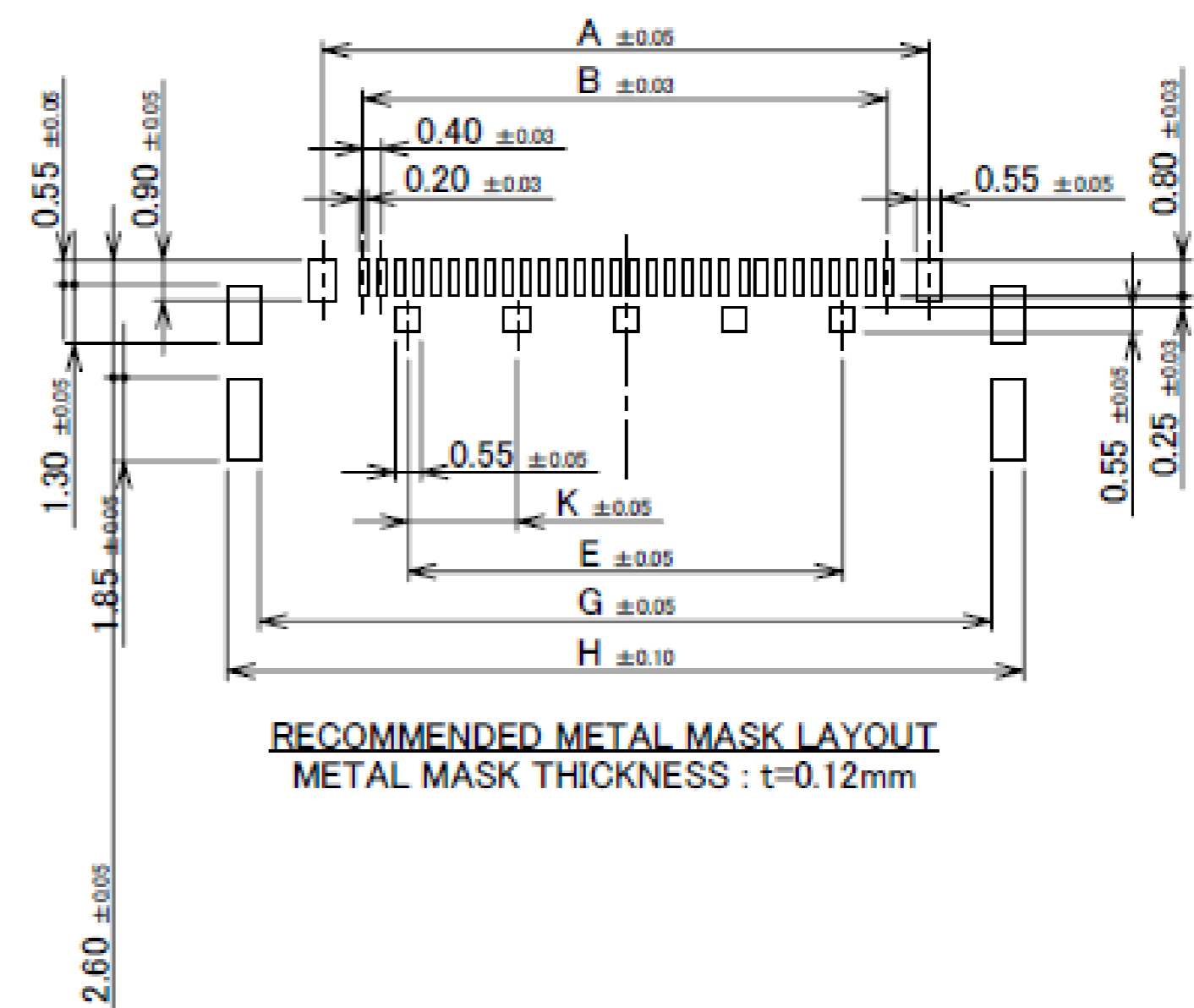
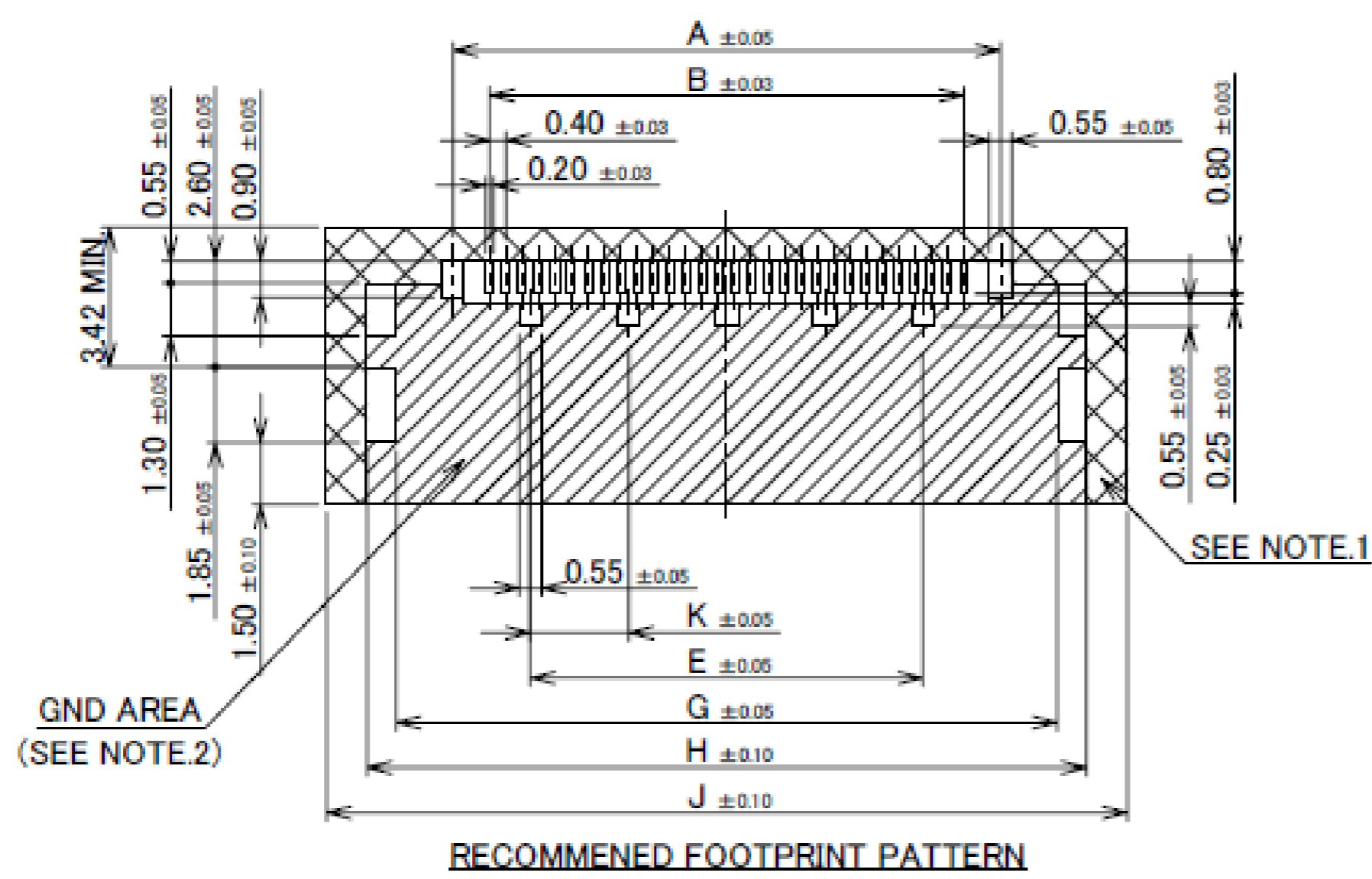

- NOTES.
1. IN CASE OF PLUG WITH PULL BAR(20633-##\*T-01S), DO NOT MOUNT ANOTHER COMPONENT IN THIS AREA.
  2. SOLDER RESIST MUST BE APPLIED TO THIS AREA.

Rev.28

# Receptacle Assembly

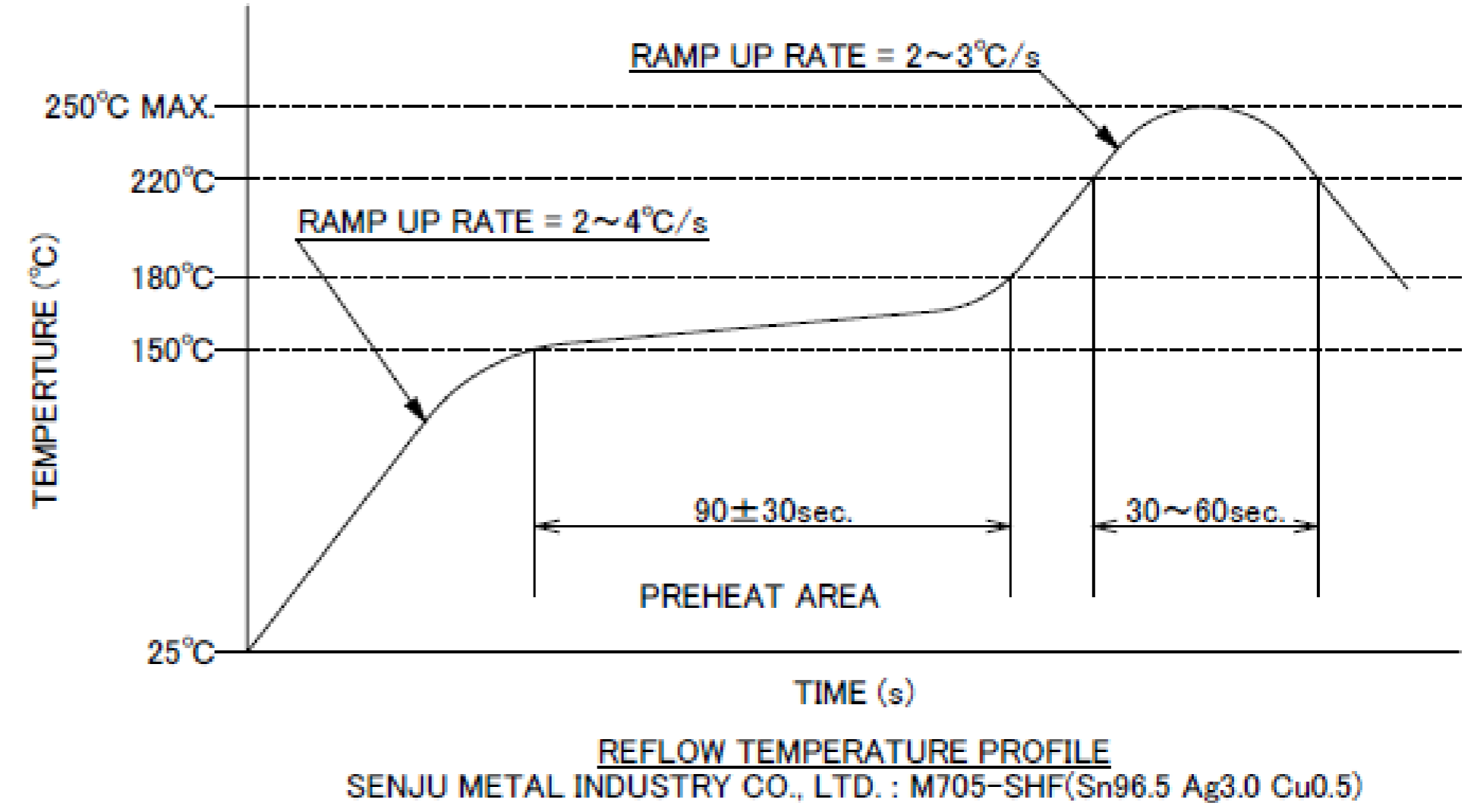
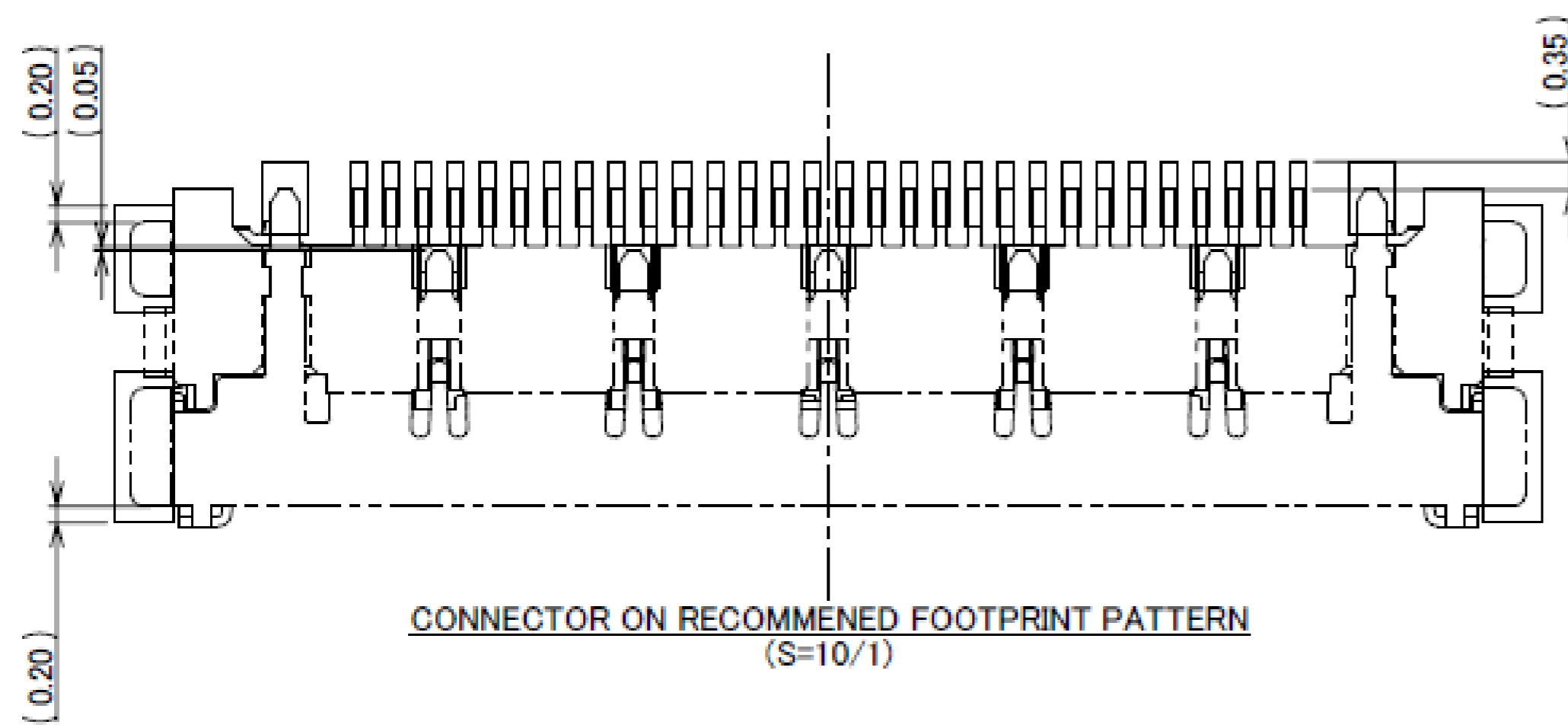

Rev.28

ITEMS	SPECIFICATION
APPLICABLE CABLE	MICRO-COAXIAL CABLE : AWG# 44 , 42 , 40 , 38 , 36 DISCRETE WIRE : AWG# 36, 34 TWINAX CABLE : AWG# 40 , 42
RATING VOLTAGE	100V AC (PER CONTACT PIN)
RATING AMPERAGE (FOR CONTACT)	0.1A AC/DC [AWG#44] PER CONTACT PIN/UP TO 60 CONTACTS 0.24A AC/DC [AWG#42] PER CONTACT PIN/UP TO 50 CONTACTS 0.3A AC/DC [AWG#40] PER CONTACT PIN/UP TO 40 CONTACTS 0.5A AC/DC [AWG#38] PER CONTACT PIN/UP TO 14 CONTACTS 0.8A AC/DC [AWG#36] PER CONTACT PIN/UP TO 6 CONTACTS 1.0A AC/DC [AWG#34] PER CONTACT PIN/UP TO 4 CONTACTS TESTING BY A REAL MACHINE IS RECOMMENDED BECAUSE TEMPERATURE RISE MAY AFFECTED BY ACTUAL SITUATION.
OPERATING TEMPERATURE	233~358K (-40°C~85°C)
OPERATING HUMIDITY	85% MAX. (NON-CONDENSING)
CONTACT RESISTANCE	INITIAL : 180mohm MAX. (AWG#34) / AFTER TEST : $\triangle$ 140mohm MAX. 275mohm MAX. (AWG#36) 360mohm MAX. (AWG#38) 600mohm MAX. (AWG#40) 700mohm MAX. (AWG#42) 1080mohm MAX. (AWG#44)
GROUND SHELL RESISTANCE	INITIAL : 50mohm MAX. / AFTER TEST : $\triangle$ 140mohm MAX.
INSULATION RESISTANCE	INITIAL : 1000Mohm MIN. / AFTER TEST : 500Mohm MIN.
DIELECTRIC WITHSTANDING VOLTAGE	AC250V 1min
DURABILITY	30 CYCLES
MATING FORCE (INITIAL / AFTER 30 CYCLES)	10P : 7.80N MAX. 40P : 19.40N MAX. 12P : 8.20N MAX. 50P : 24.25N MAX. 20P : 9.70N MAX. 60P : 29.10N MAX. 30P : 14.55N MAX.
UNMATING FORCE (INITIAL / AFTER 30 CYCLES)	10P : 1.00N MIN. 40P : 4.00N MIN. 12P : 1.20N MIN. 50P : 5.00N MIN. 20P : 2.00N MIN. 60P : 6.00N MIN. 30P : 3.00N MIN.
CABLE RETENTION FORCE	10P : 4.90N MIN. 40P : 19.60N MIN. 12P : 5.88N MIN. 50P : 24.50N MIN. 20P : 9.80N MIN. 60P : 29.40N MIN. 30P : 14.70N MIN.
PRODUCT SPECIFICATION	PRS-1968
TEST REPORT	TR-14122 (20525-0**E-0##) / TR-16023 (20525-2**E-0##)
INSTRUCTION MANUAL	HIM-09008
ASSEMBLY MANUAL	ASM-09005
APPEARANCE CRITERIA No.	QLS-A***

Rev.12



# Custom Connectors Available

 RF Connector

MHF® series



CABLINÉ® series  
Micro-coaxial/Twinax/  
Discrete Wire Connector

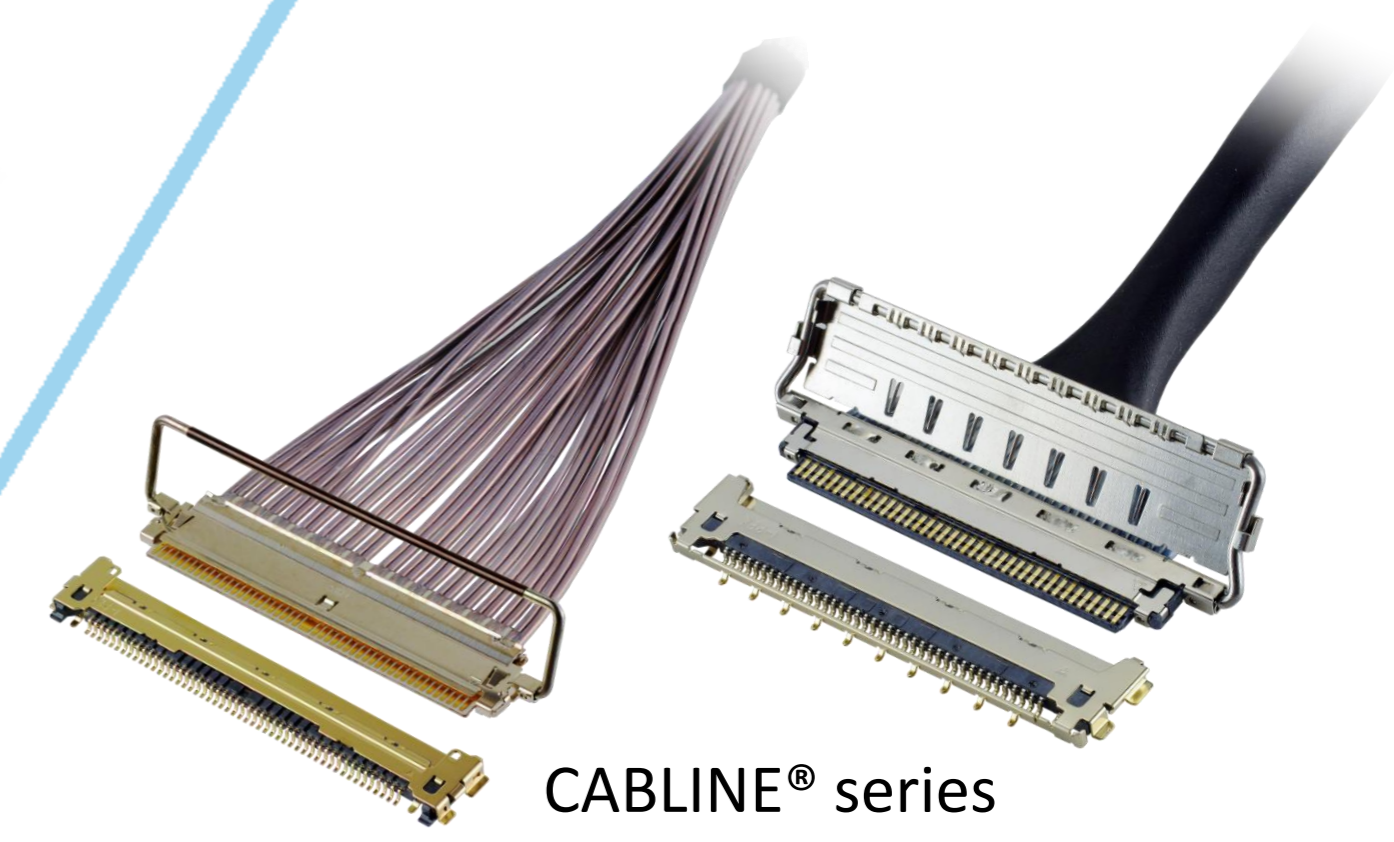

Optical Module

LIGHTPASS® series



NOVASTACK® series



Board-to-Board Connector

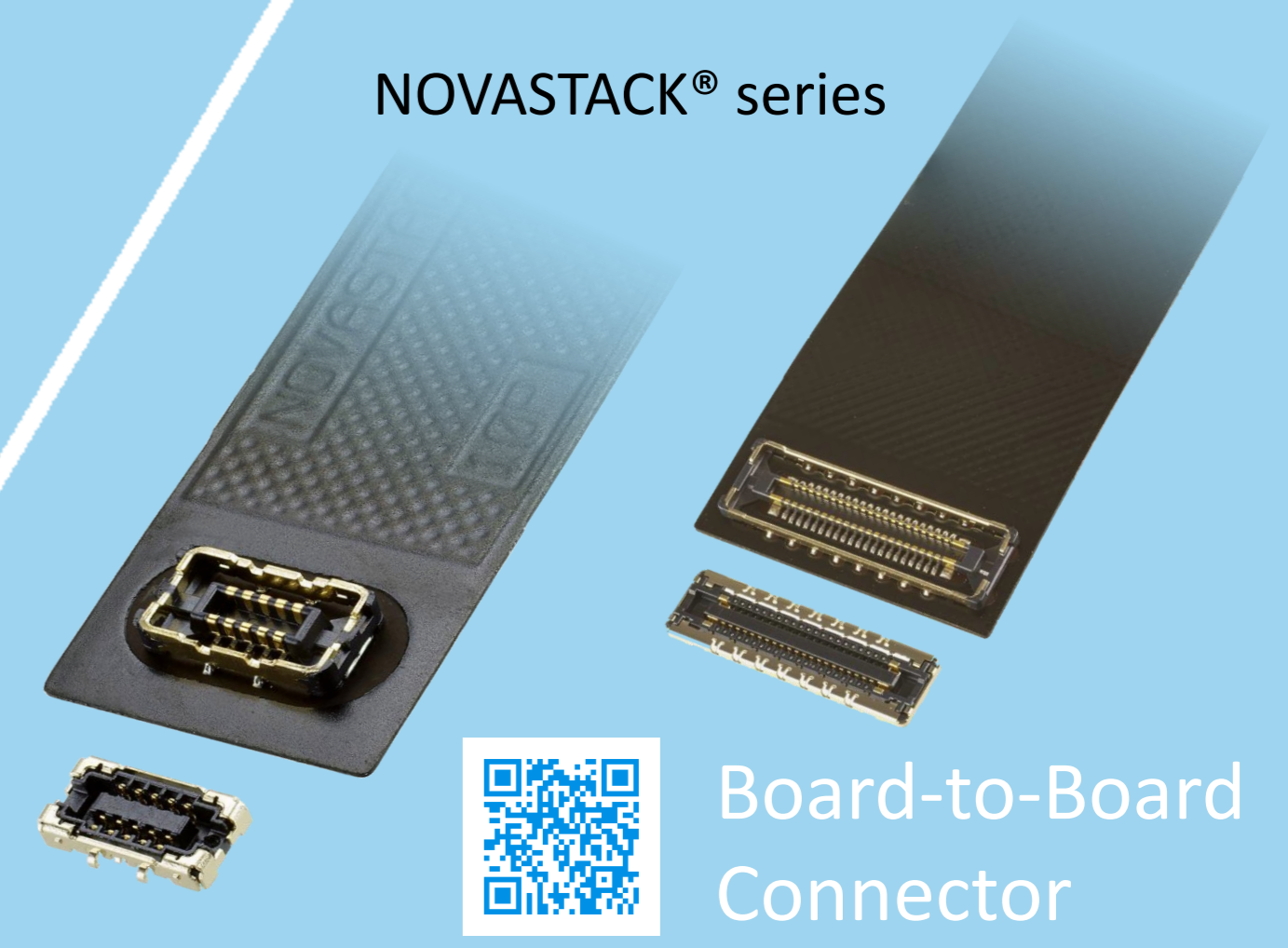

Power Connector/  
Terminal

AP series

ISH® series



MINIFLEX® series

EVAFLEX® series



FPC FFC Connector



Inquiry



MINIDOCK® series



I/O Connector

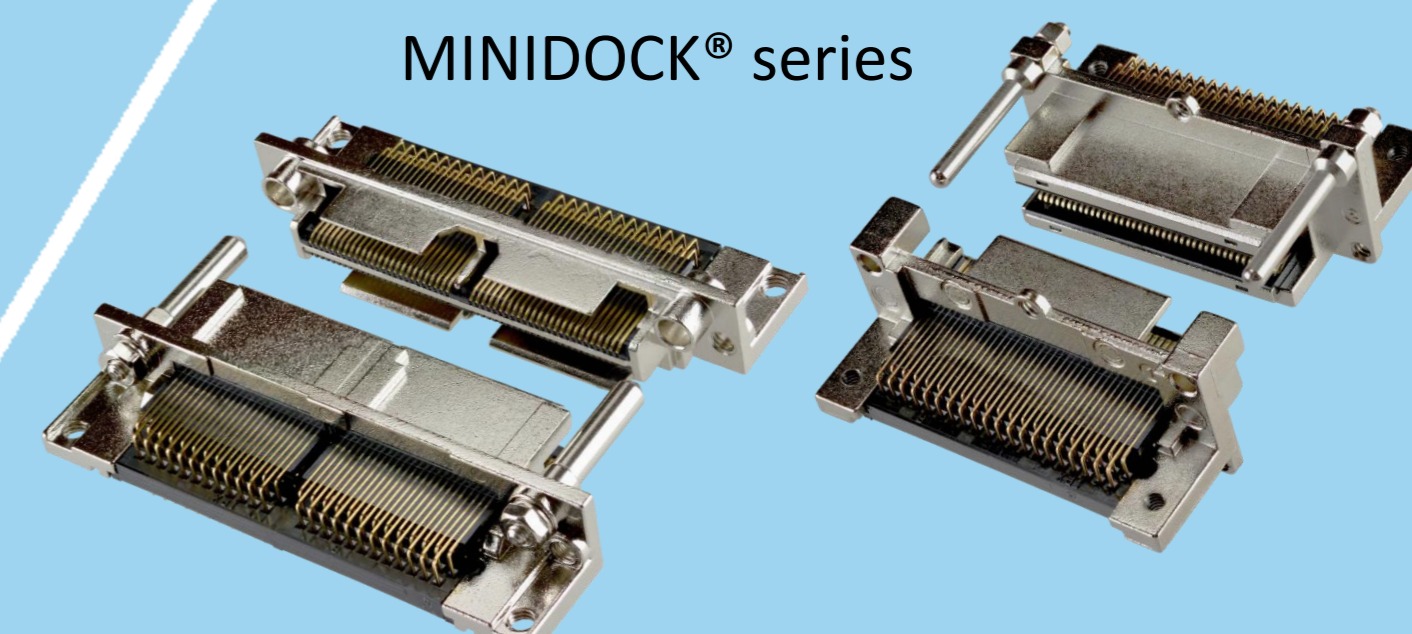

I-PEX, MHF, CABLINE, LIGHTPASS, NOVASTACK, ISH, IARPB, MINIFLEX, EVAFLEX, MINIDOCKS and ZenShield are registered trademarks of I-PEX Inc. Please note that the contents in the catalog might be changed without prior notification. I-PEX Inc. assumes no responsibility for any inaccuracies or obligation to update information on these documents. Please be sure to read and understand the latest "Precautions for Use" and "Instruction Manual" before you use our products. We shall not be responsible for any defects, damages or troubles in case you use our products without following the precautions for use. Please feel free to contact our sales representatives when you use our products for any applications that require very high reliability and safety, or that relate to human life (ex. nuclear power control, aerospace, transportation, medical equipment, safety equipment etc.).

Contact your sales representative or more detailed information.

[www.i-pex.com](http://www.i-pex.com)

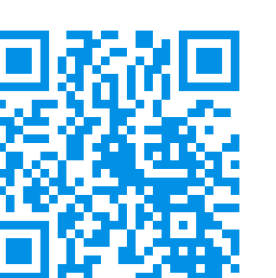

# I-PEX

© I-PEX Inc. 2024  
All rights reserved