

CABLINE®-CAF

带屏蔽功能的机械锁扣和多点接地设计，0.4mm 间距，水平对插款的FPC 型公头连接器

Product Specifications:

Mating type		Horizontal
Board Pitch (mm)		0.4
Wiping Length (mm)		-
Mated size (mm)	Height	1.0 +/- 0.1
	Width	Formula: 5.75 + (0.4 x ? p)
	Depth	6.06
Pin Counts	Range	Up to 60
	Available	40, 60

Applicable FPC

FPC Type	Shielded/Non-shielded FPC
FPC Pitch (mm)	0.4
FPC Contact Point	Top
FPC Thickness (mm)	Contact Area: 0.26 ± 0.02
	Ground Area: 0.40 ± 0.05

Applicable Standards (Reference Only):

PCIe® Gen 4 (16 GT/s/Lane), USB3.2 Gen2 (10 Gbps/Lane)
eDP HBR 3 (8.1 Gbps/Lane), USB3.2 Gen1(5 Gbps/Lane)



*如您需要了解未列出或不在范围内的Pin数，请咨询我们。

机械锁扣防止连接器不完全嵌合及脱落/未嵌合

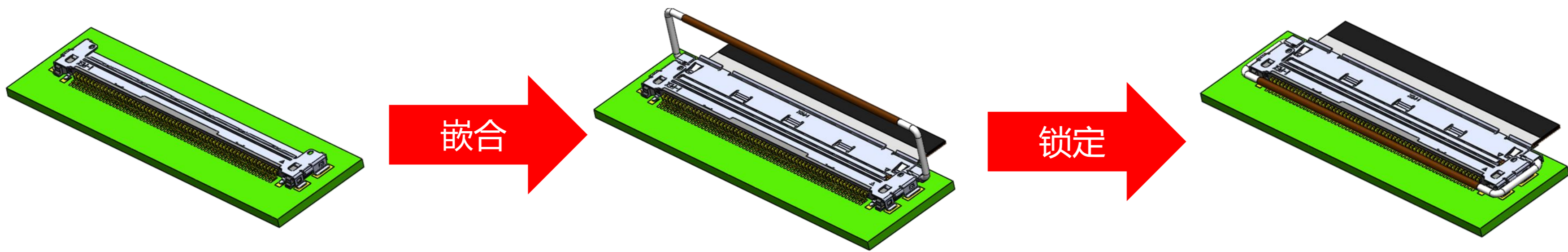

干涉

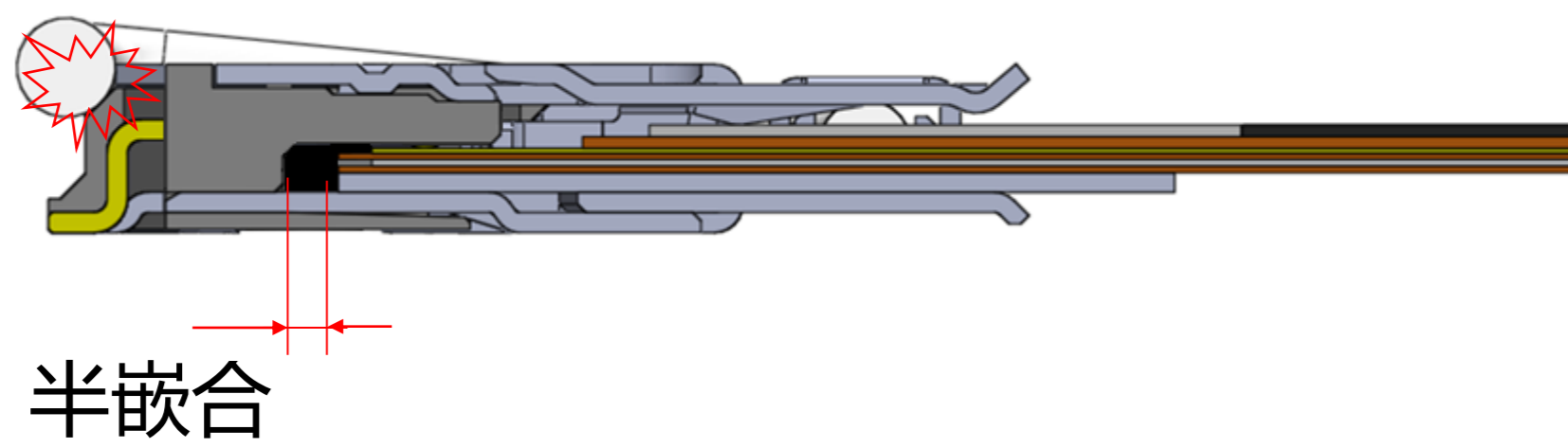

只有当公座完全和母座嵌合时，机械锁扣才能锁上。

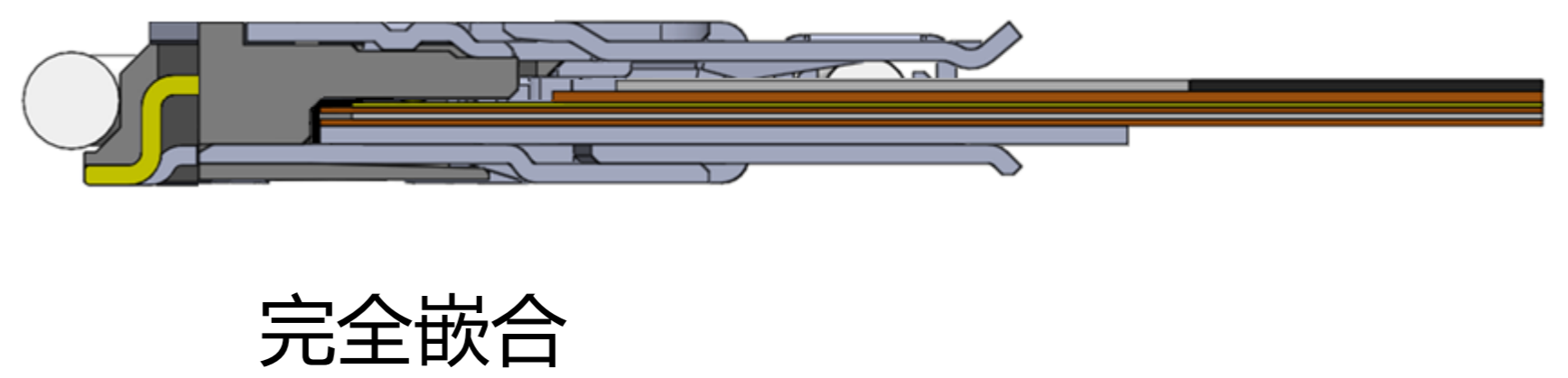

EMI 屏蔽和多点接地设计

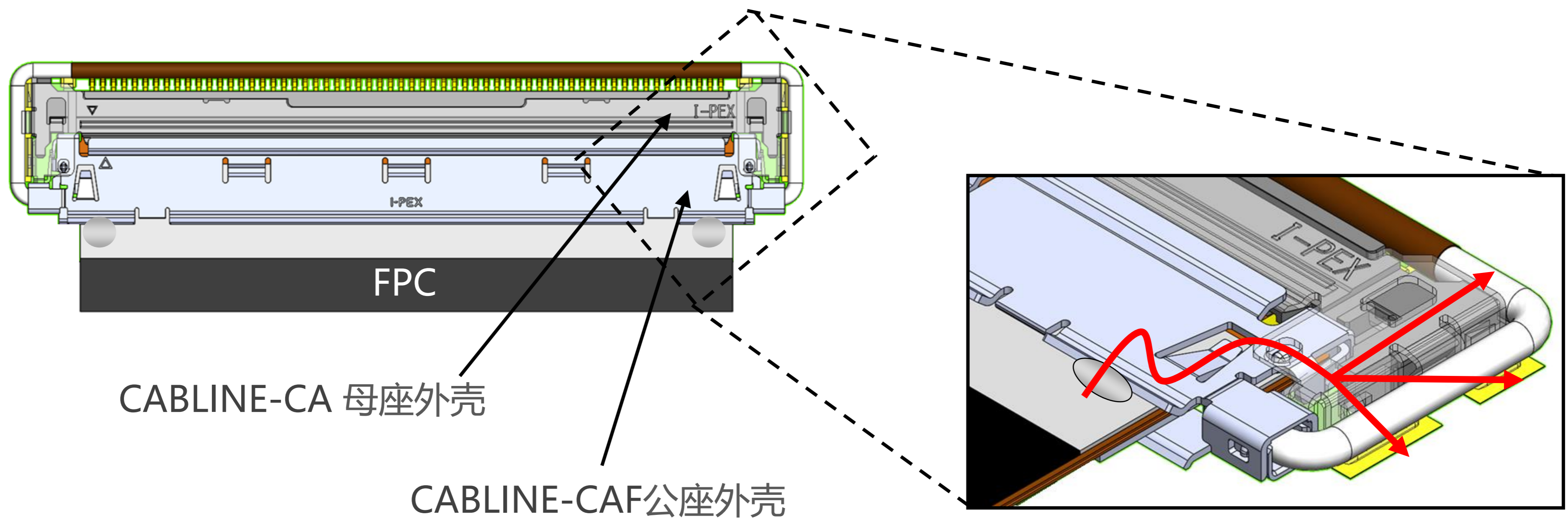

CABLINE®-CA 系列多款连接器可选

CABLINA-CA 系列 (0.4mm 间距, 水平对插款式)

CABLINA-CA 和 CA II 的母座可安装在相同布局的PCB 上

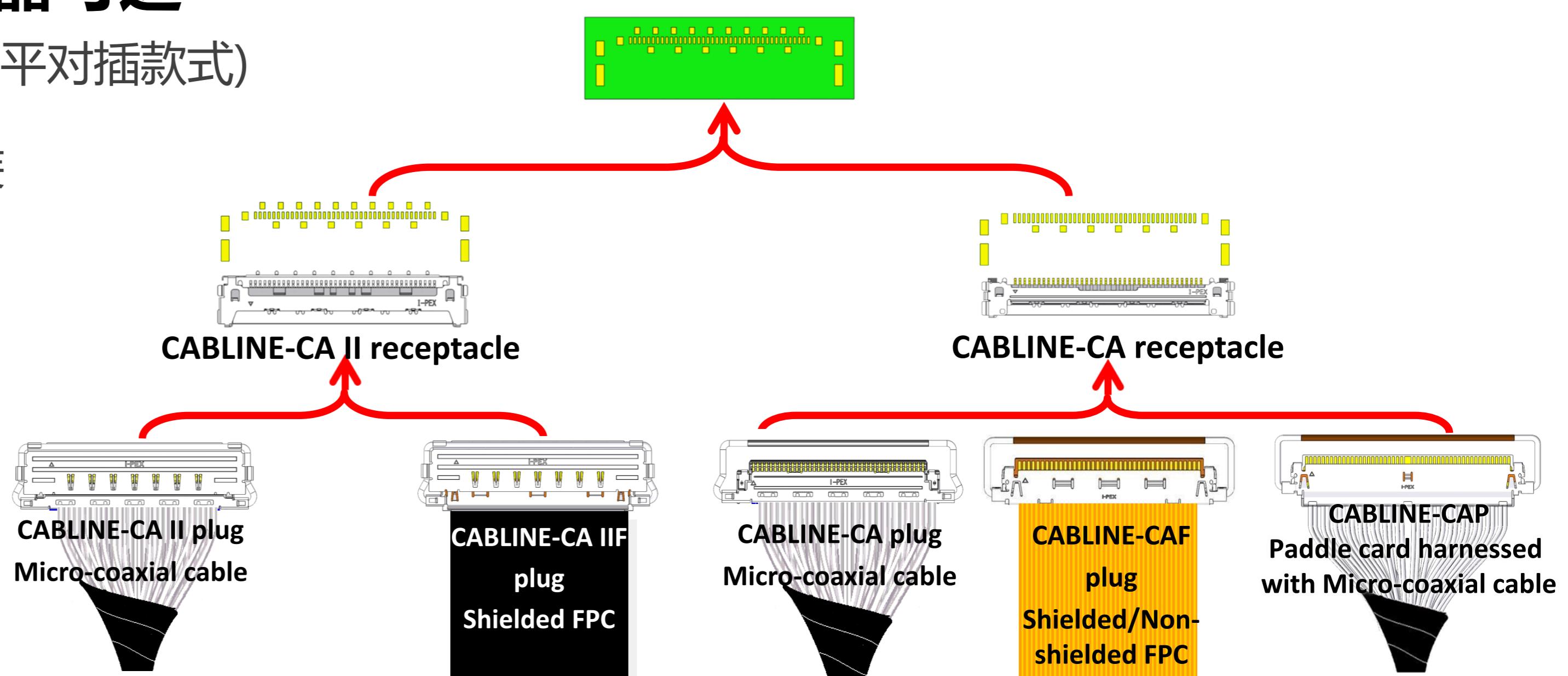

Component Parts Details

Component Parts

WITH LOCK BAR TYPE

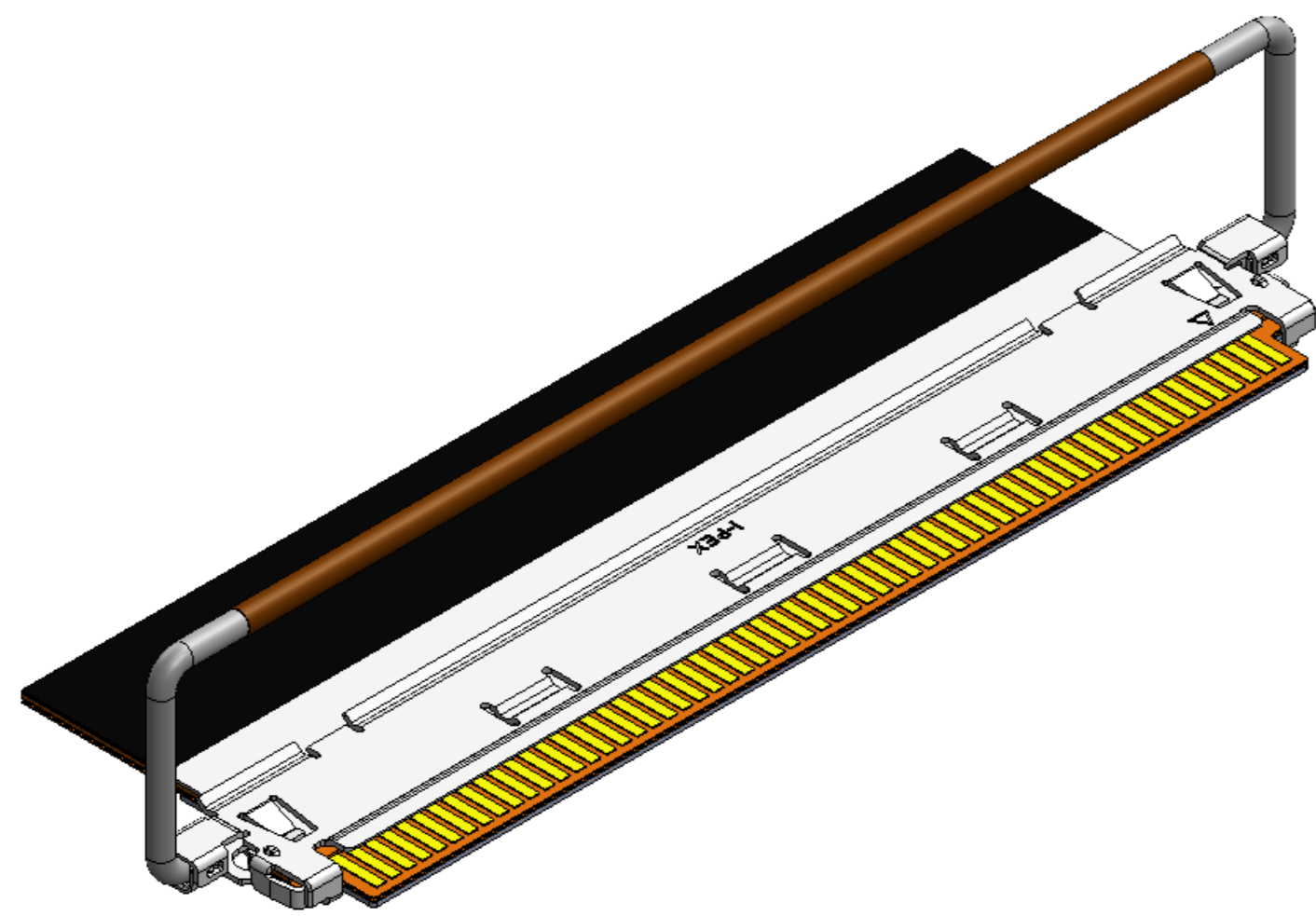

CABLINE-CAF SHELL ASS'Y PLUG with FPC

WITHOUT LOCK BAR TYPE

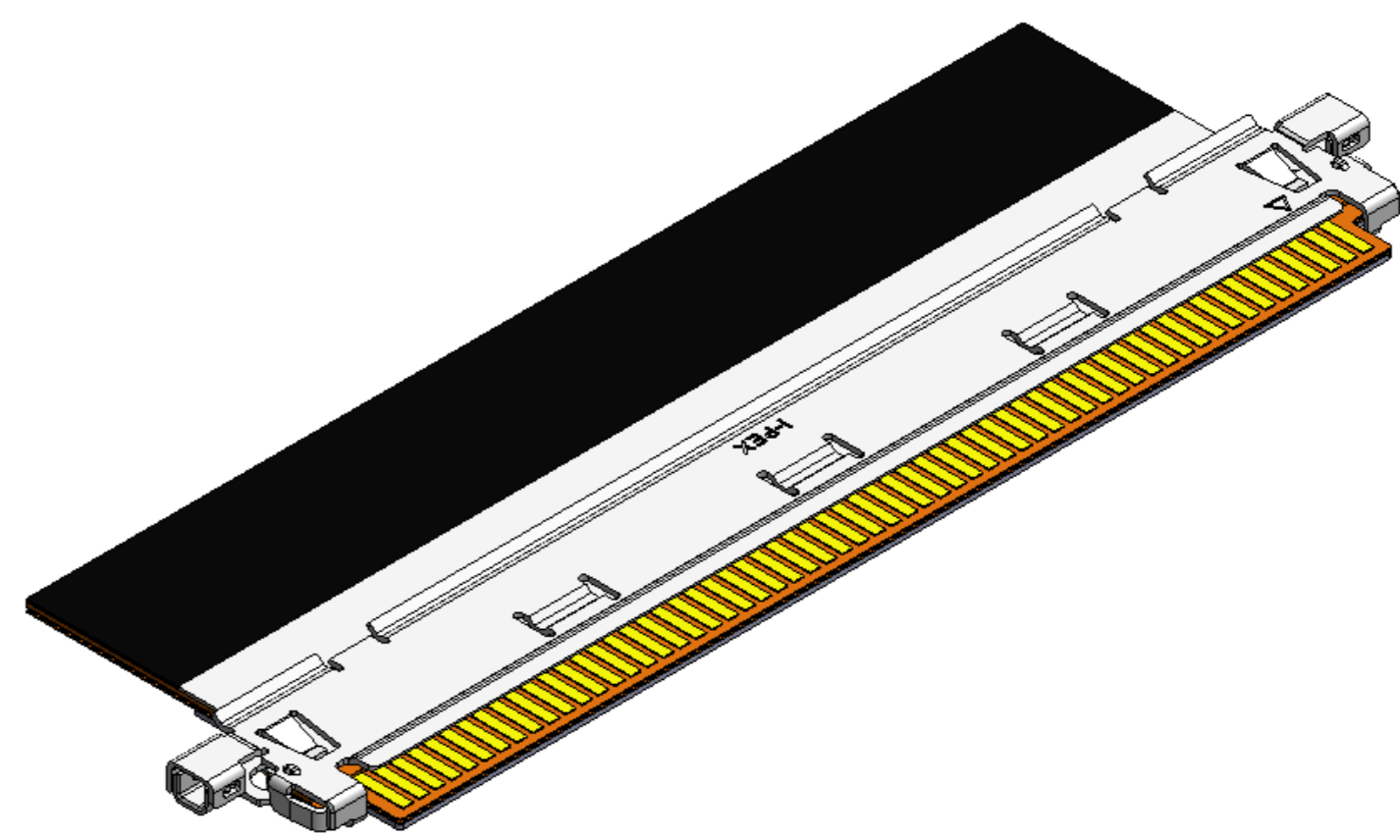

CABLINE-CAF SHELL PLUG with FPC

OR

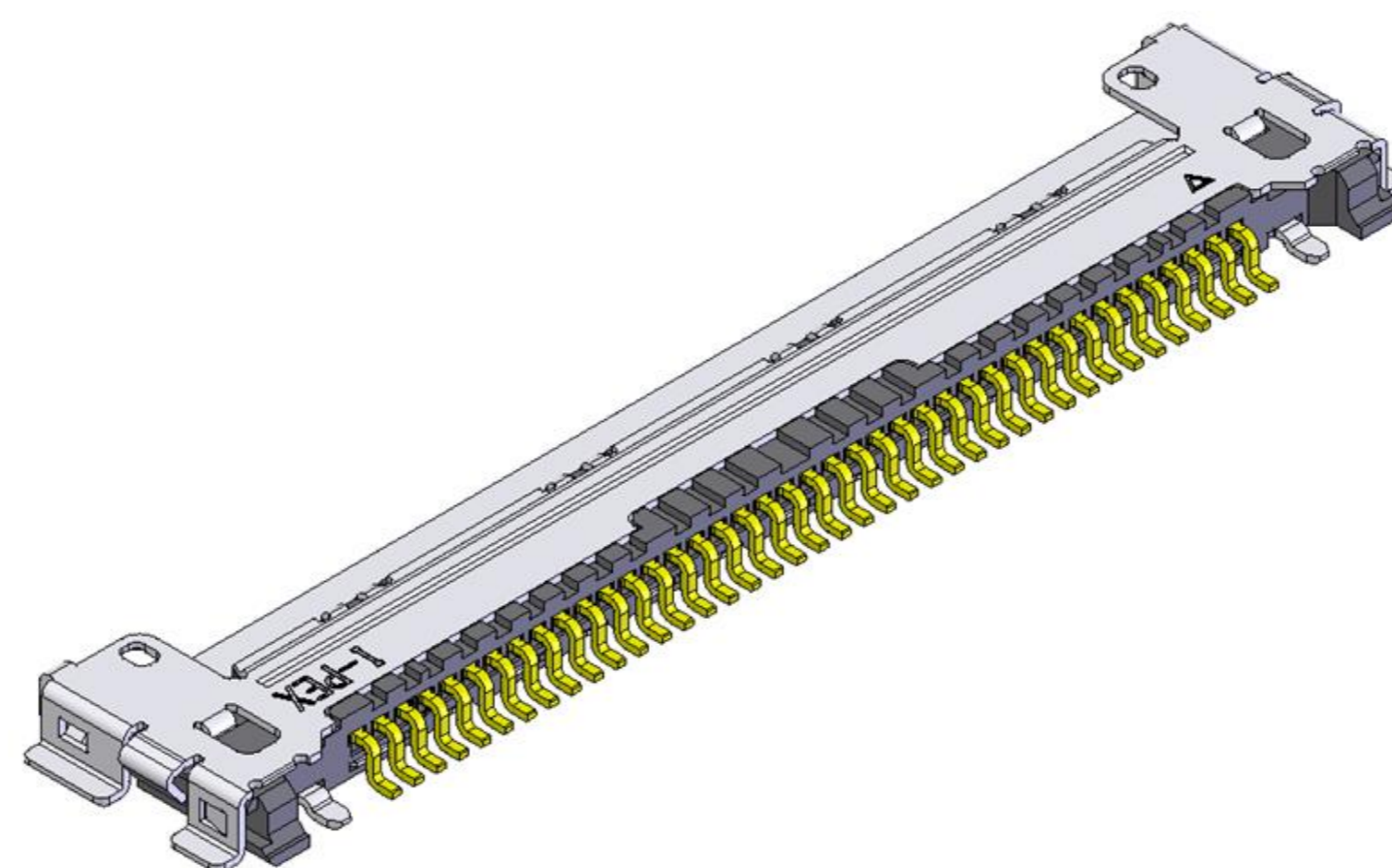

CABLINE-CA RECEPTACLE

Shell Assembly

Recommended P/N		20858-0**T-01		
PART NO.	Pos.	A	B	C
20858-040T-01	40	20.85	18.66	20.40
20858-060T-01	60	28.65	26.66	28.40

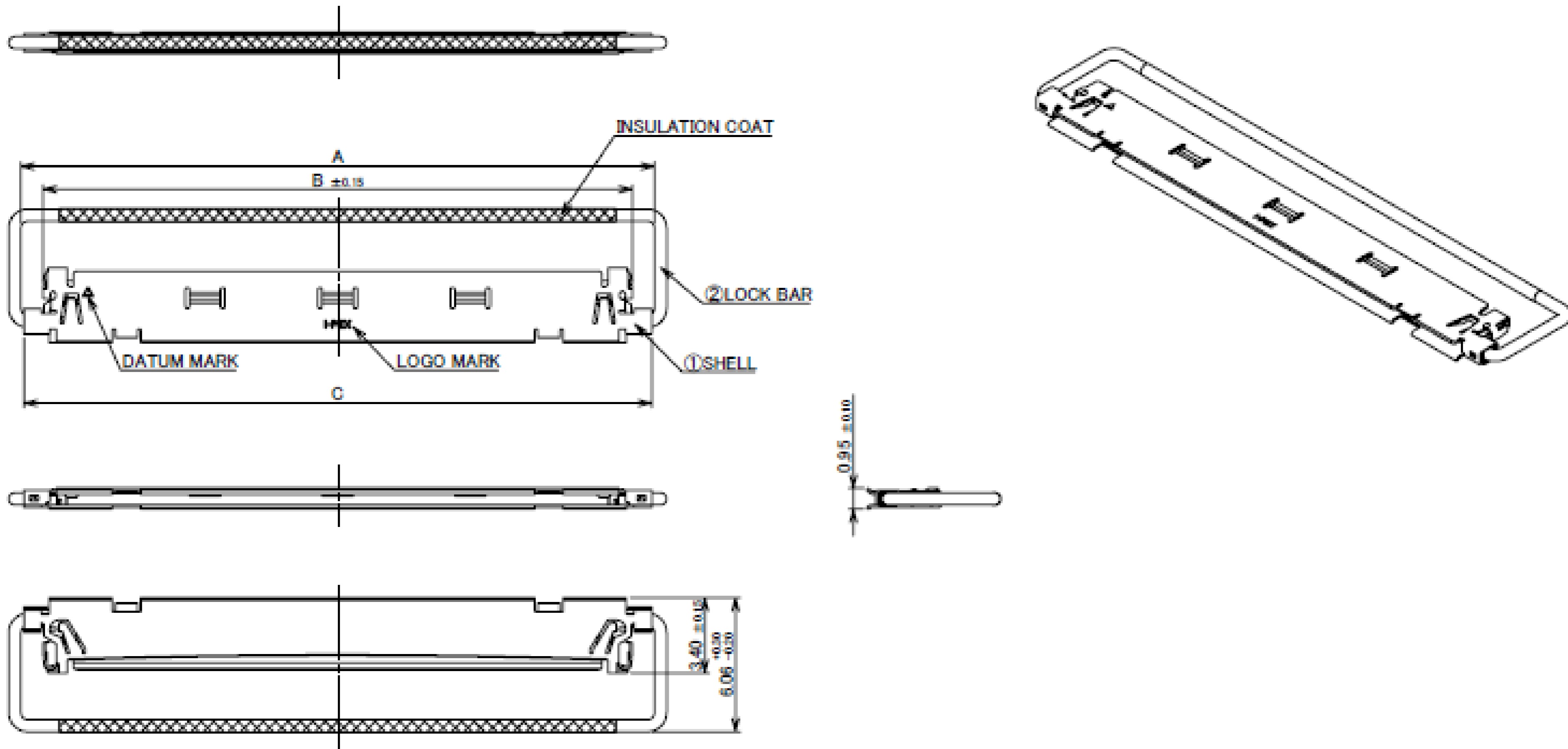
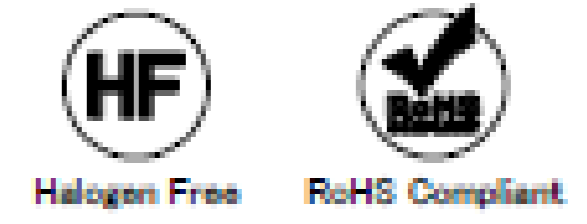

2	LOCK BAR	SUS	-
1	SHELL	PHOSPHOR BRONZE	PARTIAL Au 0.003 μm MIN. OVER Ni 1.00 μm MIN.
NO.	DISCRIPTION	MATERIAL	FINISH , REMARKS

Rev.8

PART NO.	Pos.	B	C	D	E	F
20858-040T-01	40	18.66	20.40	21.75	16.40	15.60
20858-060T-01	60	26.66	28.40	29.75	24.40	23.60

FPC ASSEMBLY STATE

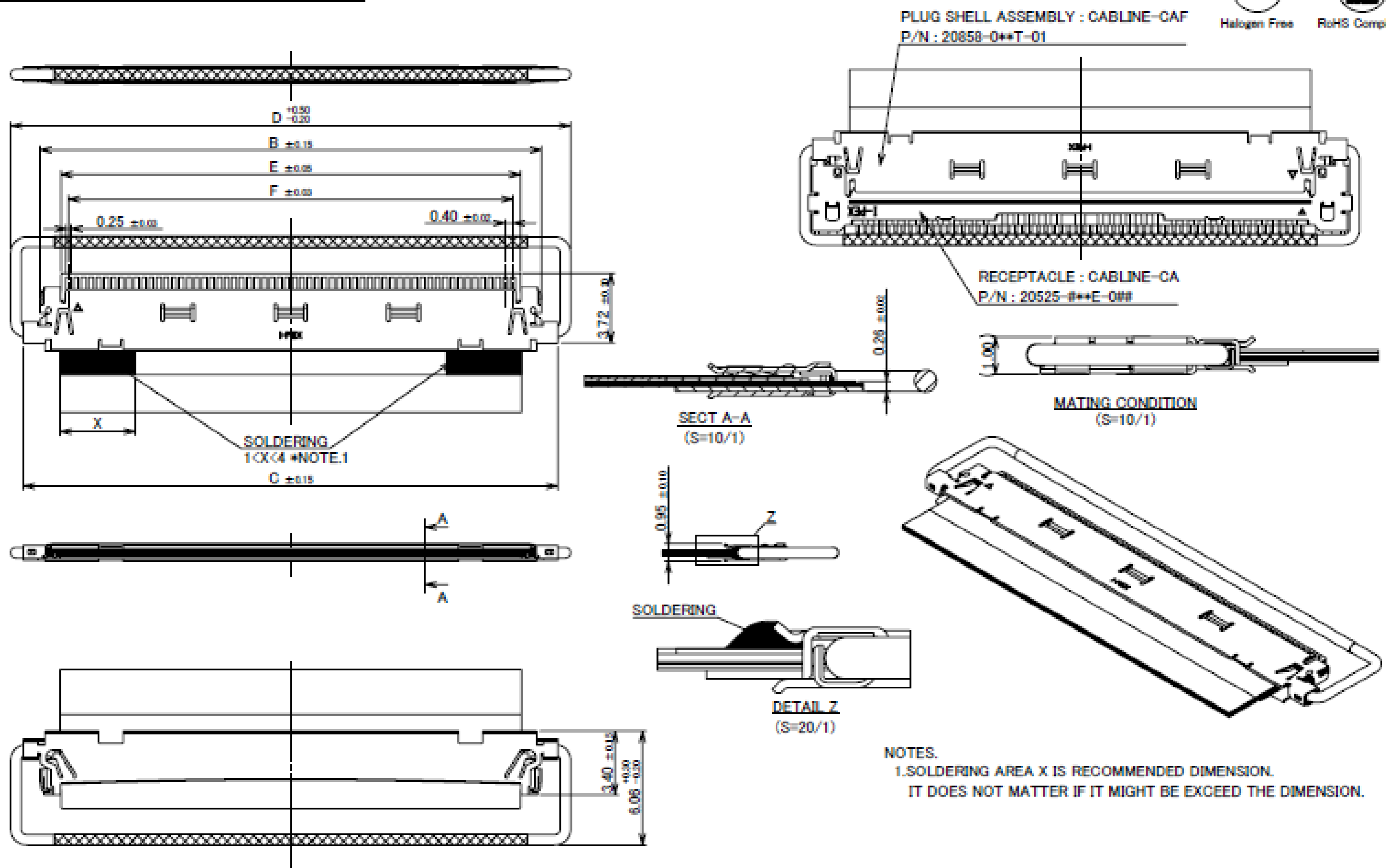
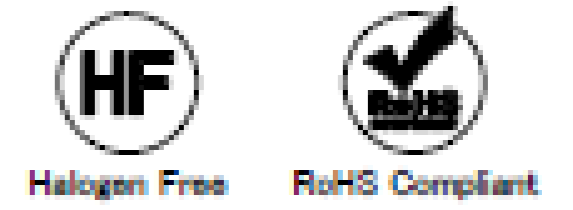

Rev.8

Shell Assembly

PART NO.	Pos.	E	F	G	H
20858-040T-01	40	16.40	15.60	17.90	16.50
20858-060T-01	60	24.40	23.60	25.90	24.50

RECOMMENDED FPC LAYOUT 【SHIELDED FPC】

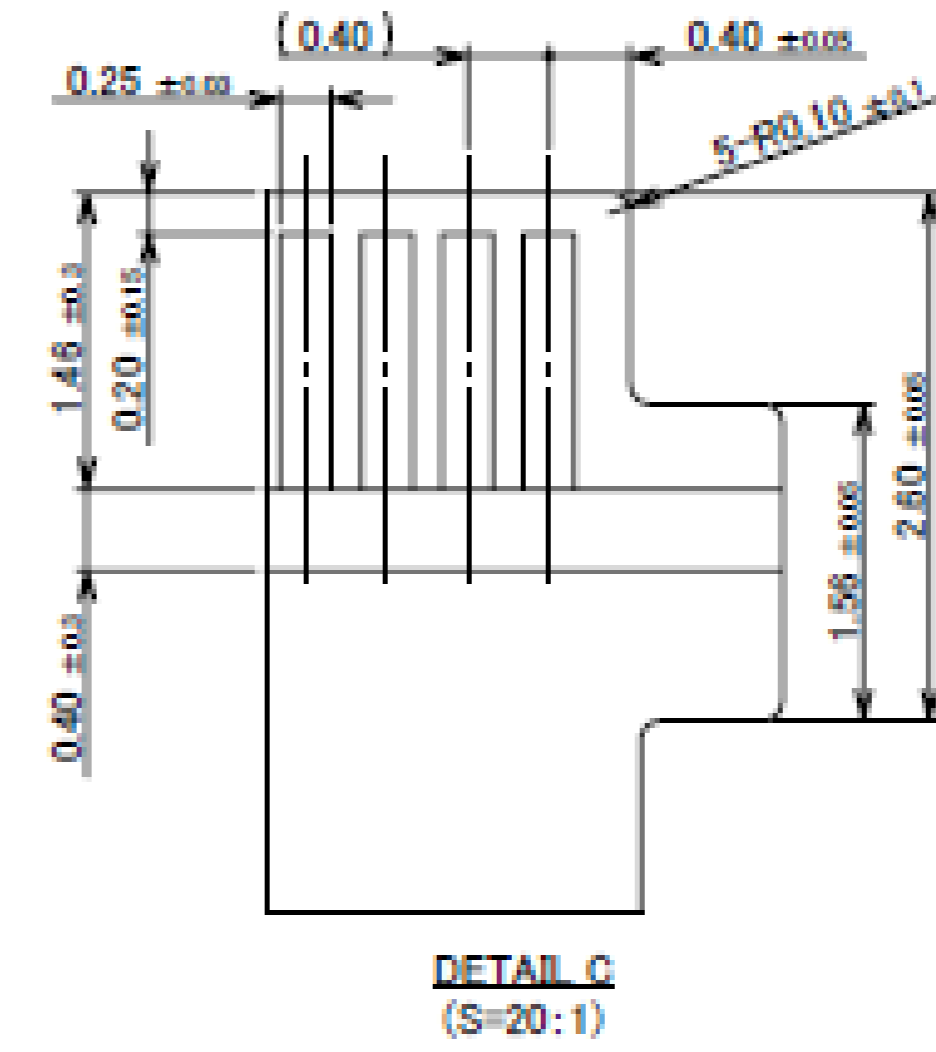
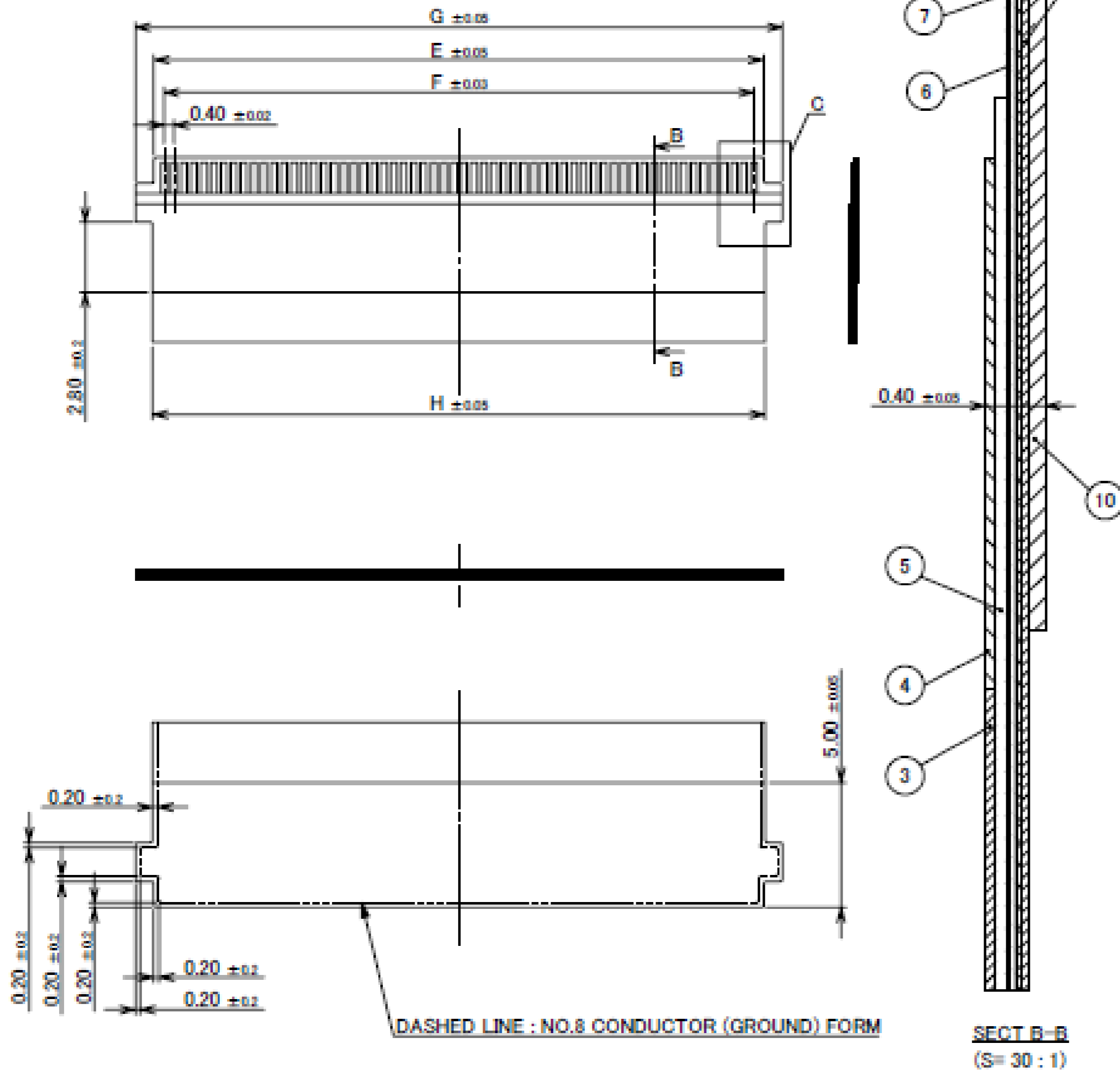

- NOTES.
- ADHESIVE SHOULD USE THERMOSETTING.
 - NO.3 : SHIELD FILM AND NO.4, NO.8 : CONDUCTOR (GROUND) ARE CARRYING OUT THE ELECTRICAL CONNECTION.
 - NO.4 : CONDUCTOR (GROUND) AND NO.8 : CONDUCTOR (GROUND) ARE CARRYING OUT THE ELECTRICAL CONNECTION.
 - NO.3 : SHIELD FILM AND NO.6 : CONDUCTOR (SIGNAL) ARE NOT CONTACTING.
 - NO.4, NO.8 : CONDUCTOR (GROUND) AND NO.6 : CONDUCTOR (SIGNAL) ARE NOT CONTACTING.

No.	DESCRIPTION	MATERIAL	PLATING
3	SHIELD FILM	-	-
4	CONDUCTOR (GROUND)	Cu	Ni, Au
5	INSULATOR	-	-
6	CONDUCTOR (SIGNAL)	Cu	Ni, Au
7	INSULATOR	-	-
8	CONDUCTOR (GROUND)	Cu	Ni
9	INSULATOR	-	-
10	REINFORCING TAPE	-	-

Rev.8

PART NO.	Pos.	E	F	G	H
20858-040T-01	40	16.40	15.60	17.90	16.50
20858-060T-01	60	24.40	23.60	25.90	24.50

RECOMMENDED FPC LAYOUT 【NON SHIELDED FPC】

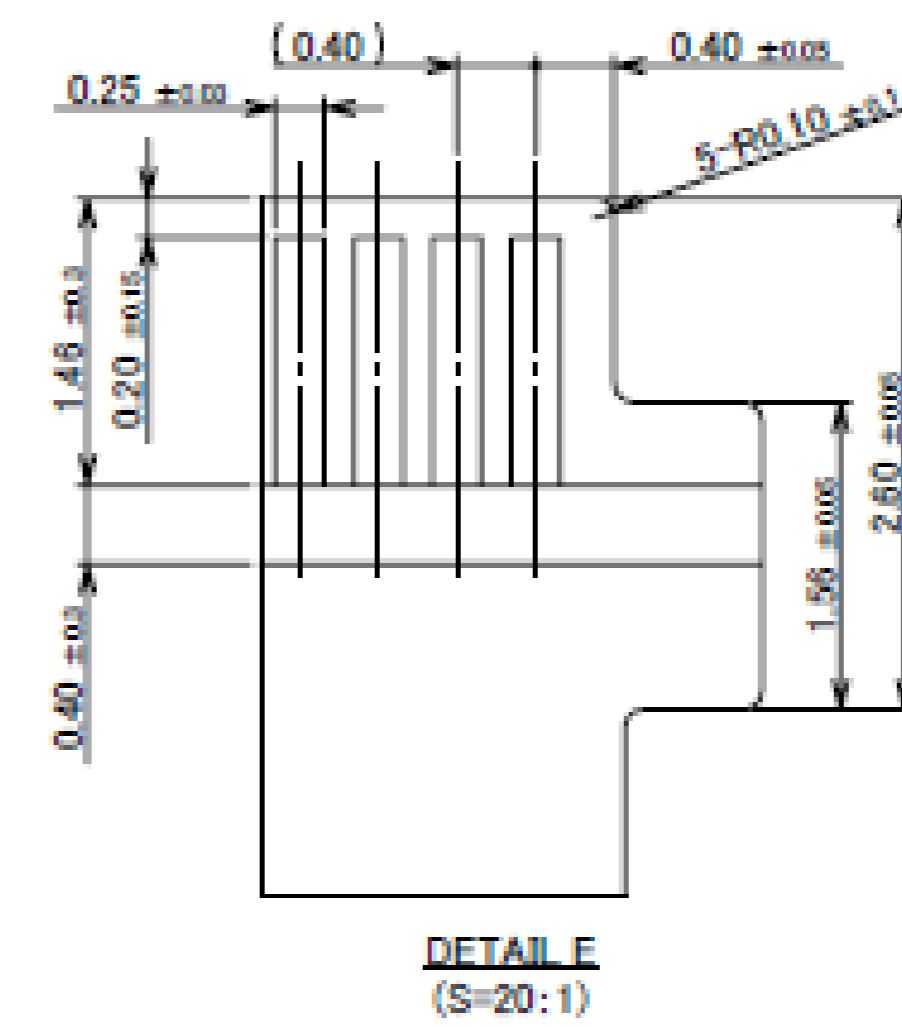
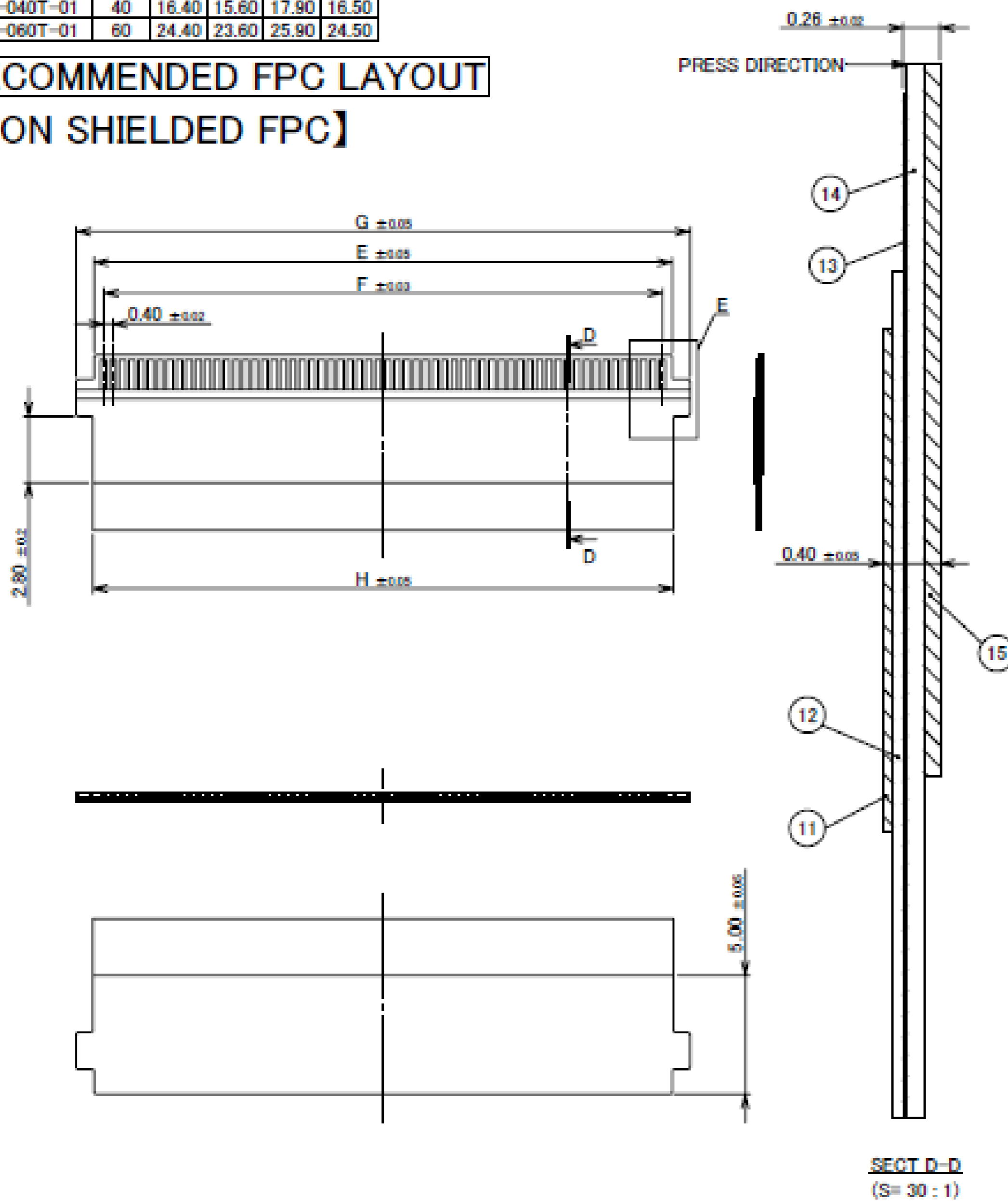

- NOTES.
- ADHESIVE SHOULD USE THERMOSETTING.
 - NO.11 : CONDUCTOR (GROUND) AND NO.1 : SHELL ARE CARRYING OUT THE ELECTRICAL CONNECTION BY SOLDERING.
 - NO.11 : CONDUCTOR (GROUND) AND NO.13 : CONDUCTOR (SIGNAL) ARE NOT CONTACTING.

No.	DESCRIPTION	MATERIAL	PLATING
11	CONDUCTOR (GROUND)	Cu	Ni, Au
12	INSULATOR	-	-
13	CONDUCTOR (SIGNAL)	Cu	Ni, Au
14	INSULATOR	-	-
15	REINFORCING TAPE	-	-

Rev.8

Shell Assembly

ITEMS	SPECIFICATION
RATING VOLTAGE	100V AC (PER CONTACT)
RATING AMPERAGE (FOR SIGNAL CONTACT)	0.5A AC/DC (PER CONTACT) ※AVAILABLE UP TO 14PIN 0.3A AC/DC (PER CONTACT) ※AVAILABLE UP TO ALL PIN
OPERATING TEMPERATURE	233~358K(-40°C~+85°C)
OPERATING HUMIDITY	85% MAX.(NON-CONDENSING)
CONTACT RESISTANCE (FOR SIGNAL CONTACT)	INITIAL : 60mohm MAX. / AFTER TEST : \triangleleft40mohm MAX.
GROUND SHELL RESISTANCE	INITIAL : 60mohm MAX. / AFTER TEST : \triangleleft40mohm MAX.
INSULATION RESISTANCE	INITIAL : 1000Mohm MIN. / AFTER TEST : 500Mohm MIN.
DIELECTRIC WITHSTANDING VOLTAGE	AC250V 1min
DURABILITY	30 CYCLES
MATING FORCE (INITIAL / AFTER TEST)	40P : 11.07N MAX. 60P : 16.61N MAX.
UNMATING FORCE (INITIAL / AFTER TEST)	40P : 1.44N MIN. 60P : 2.16N MIN.
PRODUCT SPECIFICATION	PRS-2465
TEST REPORT	TR-18016
PACKING STANDARD	PST-17138
INSTRUCTION MANUAL	HIM-18016
ASSEMBLY MANUAL	ASM-18005
APPEARANCE CRITERIA No.	QLS-A***

Rev.8

Receptacle Assembly

Recommended P/N	20525-0**E-02(12~60P)	20525-210E-02(10P)				
PART NO.	POS.	A	B	C	D	F
20525-#10E-02	10	5.40	3.60	8.43	9.20	4.30
20525-#12E-02	12	6.20	4.40	9.23	10.00	5.10
20525-#20E-02	20	9.40	7.60	12.43	13.20	8.30
20525-#30E-02	30	13.40	11.60	16.43	17.20	12.30
20525-#40E-02	40	17.40	15.60	20.43	21.20	16.30
20525-#50E-02	50	21.40	19.60	24.43	25.20	20.30
20525-#60E-02	60	25.40	23.60	28.43	29.20	24.30

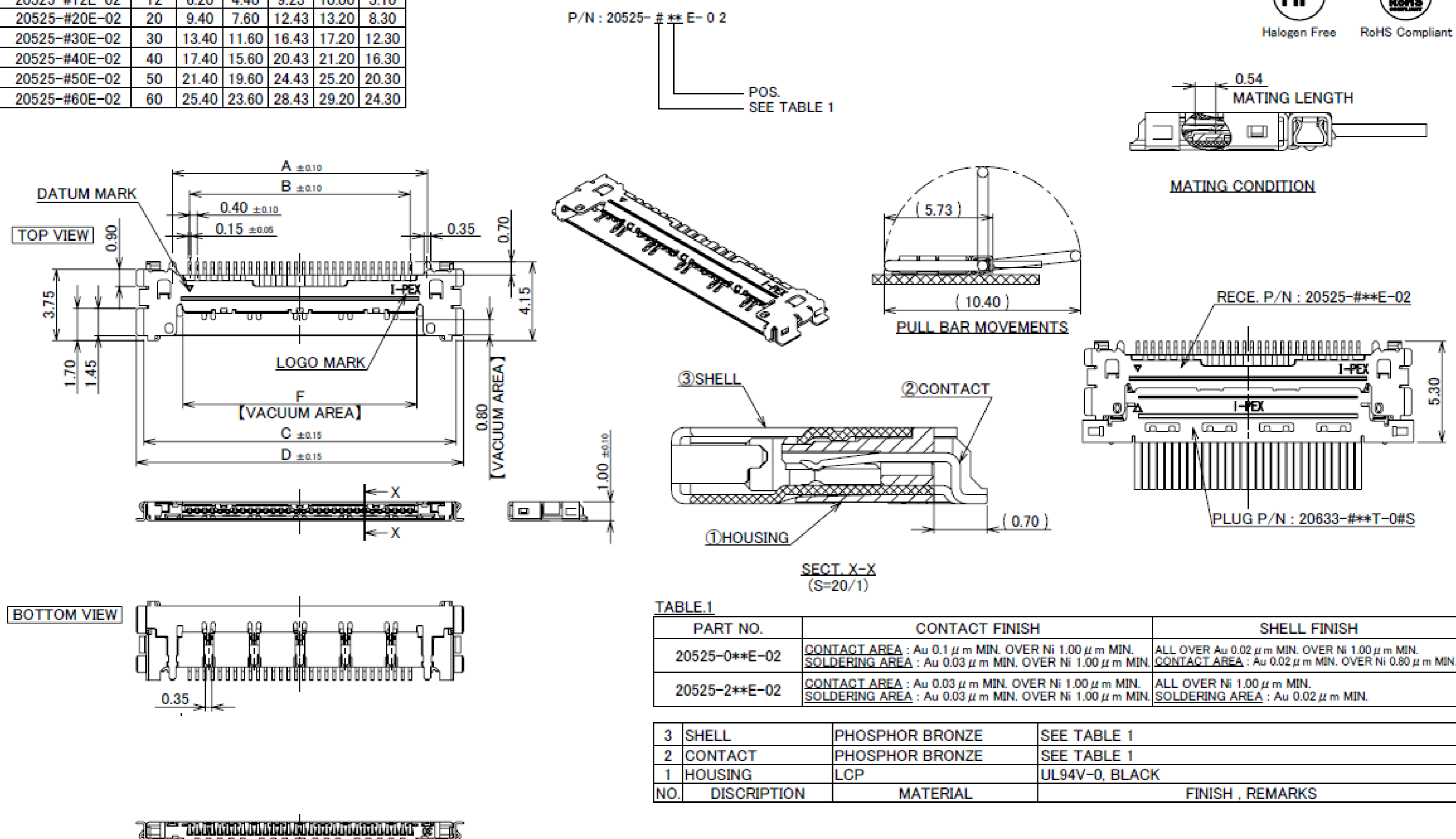

Rev.28

Receptacle Assembly

PART NO.
20525-##*E-02

BOTTOM VIEW

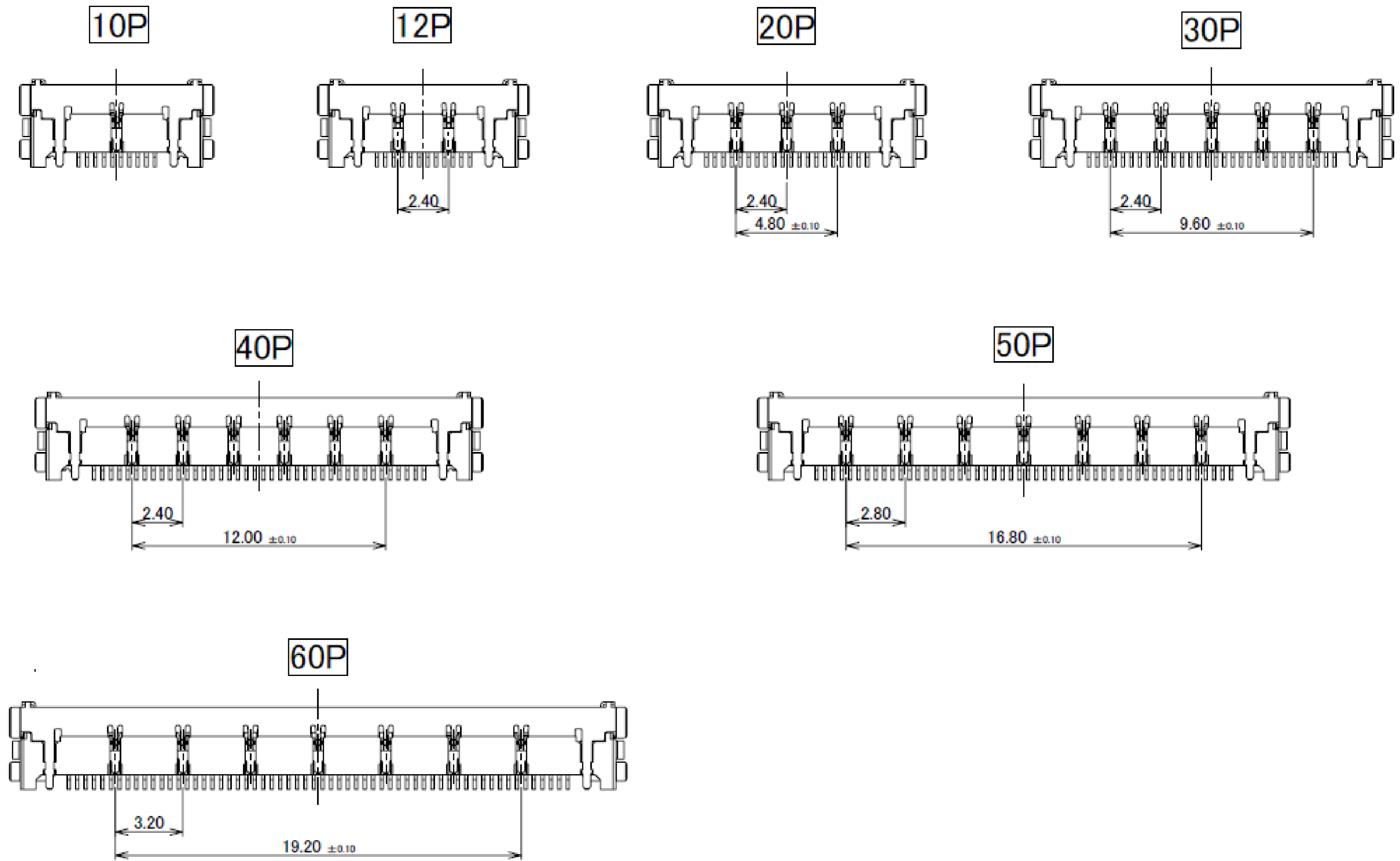

Rev.28

Receptacle Assembly

PART NO.	POS.	A	B	E	G	H	J	K
20525-#10E-02	10	5.40	3.60	-	8.18	9.60	11.60	-
20525-#12E-02	12	6.20	4.40	2.40	8.98	10.40	12.40	-
20525-#20E-02	20	9.40	7.60	4.80	12.18	13.60	15.60	2.40
20525-#30E-02	30	13.40	11.60	9.60	16.18	17.60	19.60	2.40
20525-#40E-02	40	17.40	15.60	12.00	20.18	21.60	23.60	2.40
20525-#50E-02	50	21.40	19.60	16.80	24.18	25.60	27.60	2.80
20525-#60E-02	60	25.40	23.60	19.20	28.18	29.60	31.60	3.20

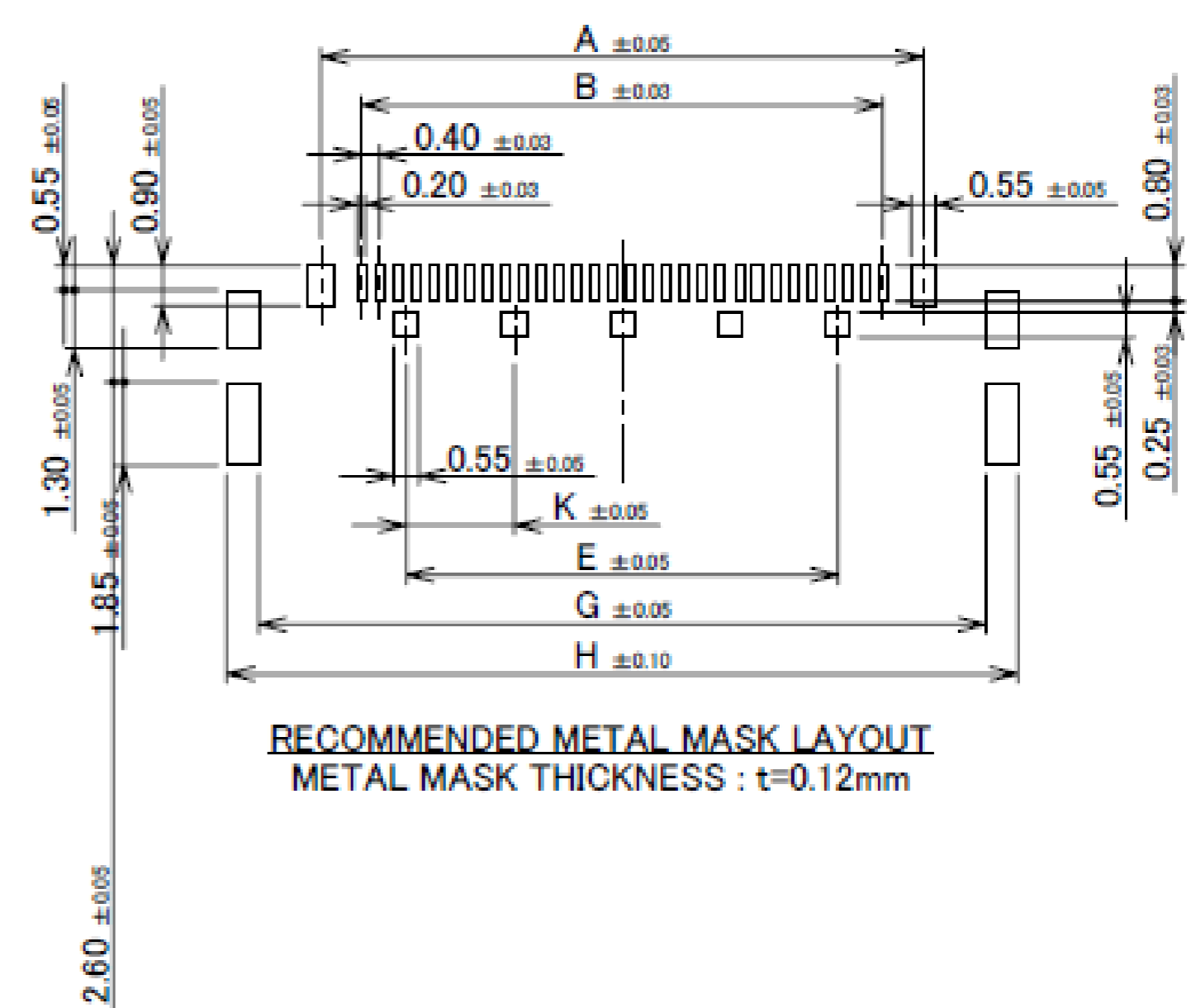
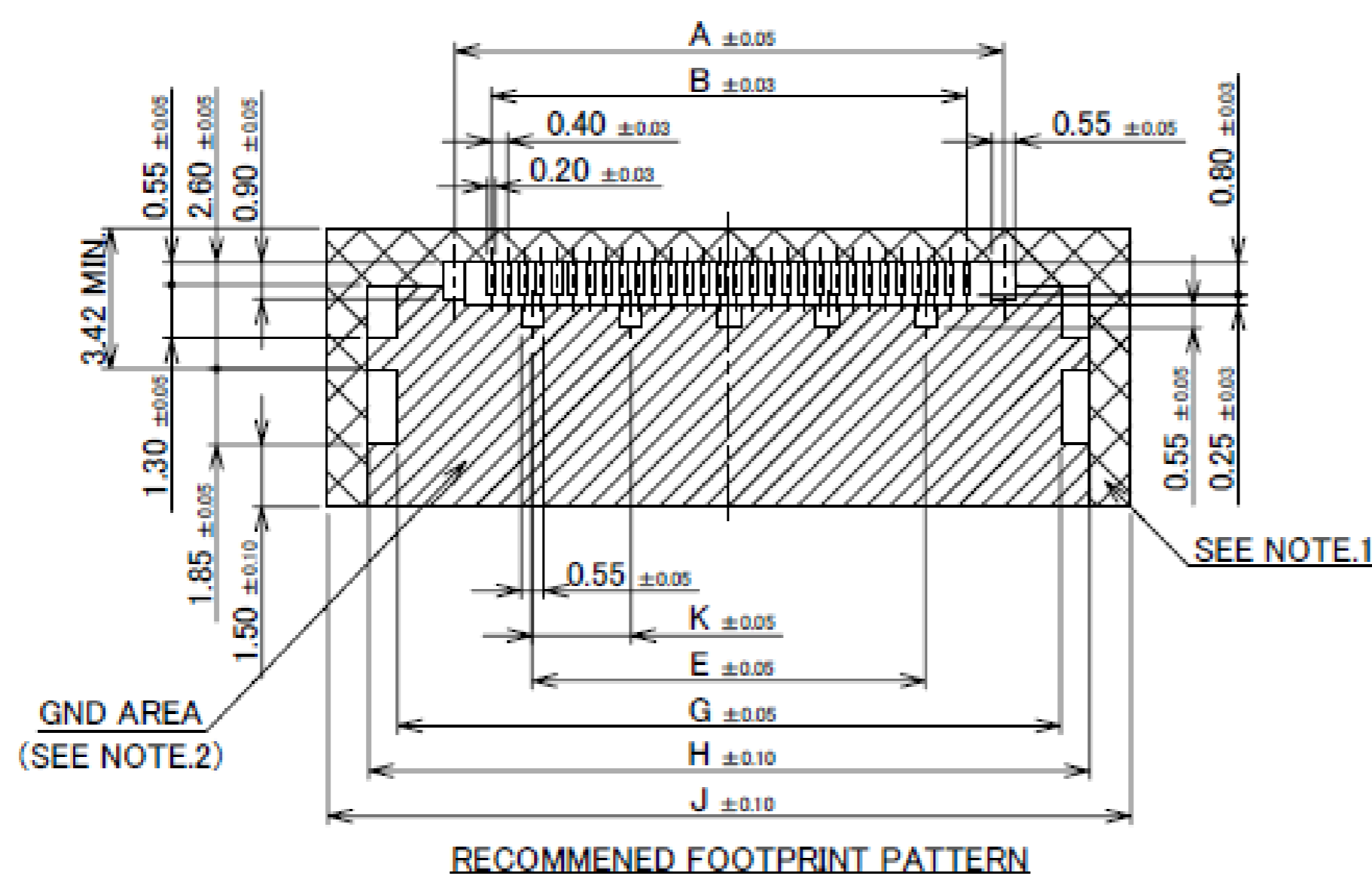

- NOTES:
 1. IN CASE OF PLUG WITH PULL BAR(20633-##*T-01S), DO NOT MOUNT ANOTHER COMPONENT IN THIS AREA.
 2. SOLDER RESIST MUST BE APPLIED TO THIS AREA.

Rev.28

Receptacle Assembly

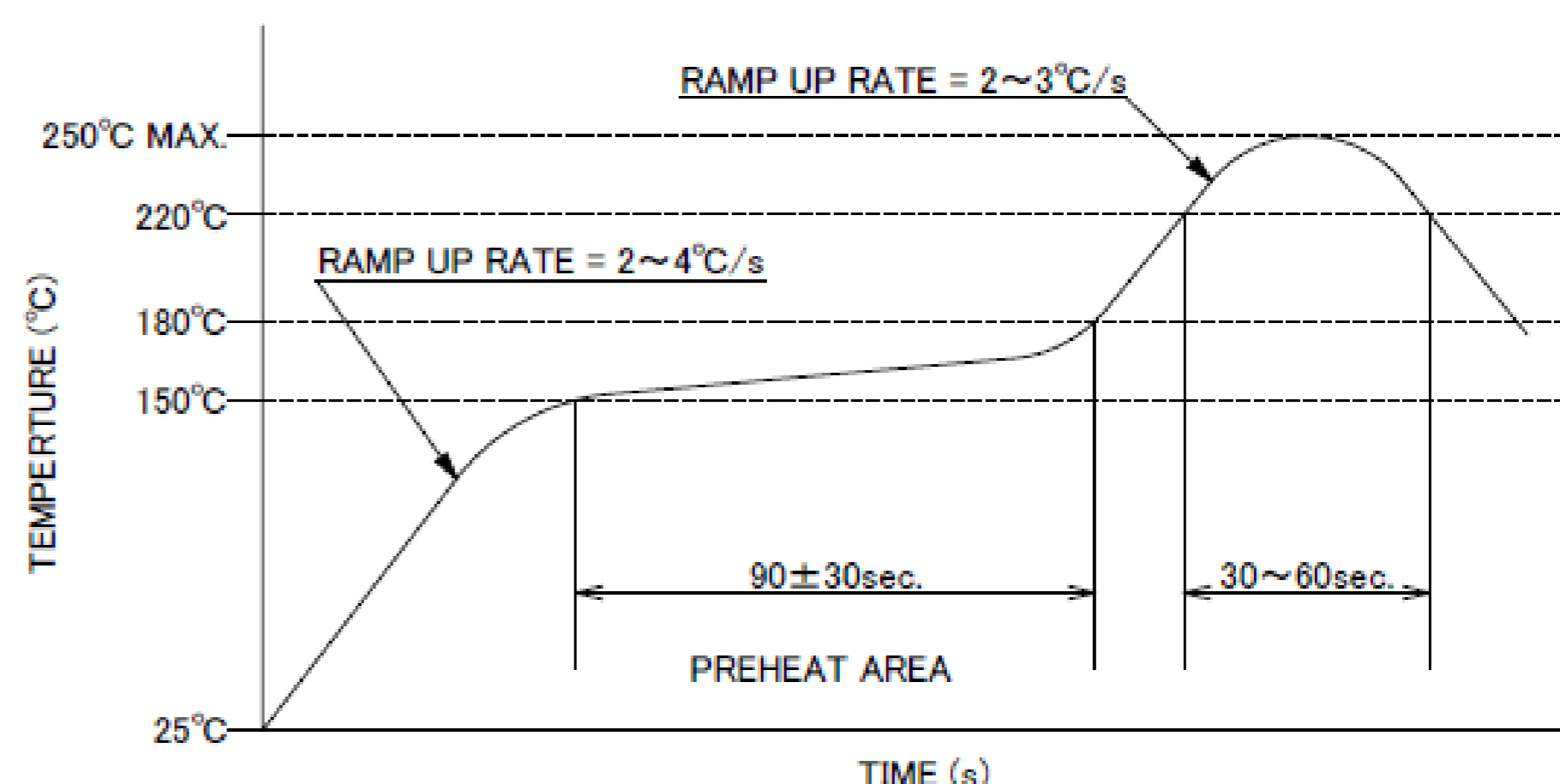
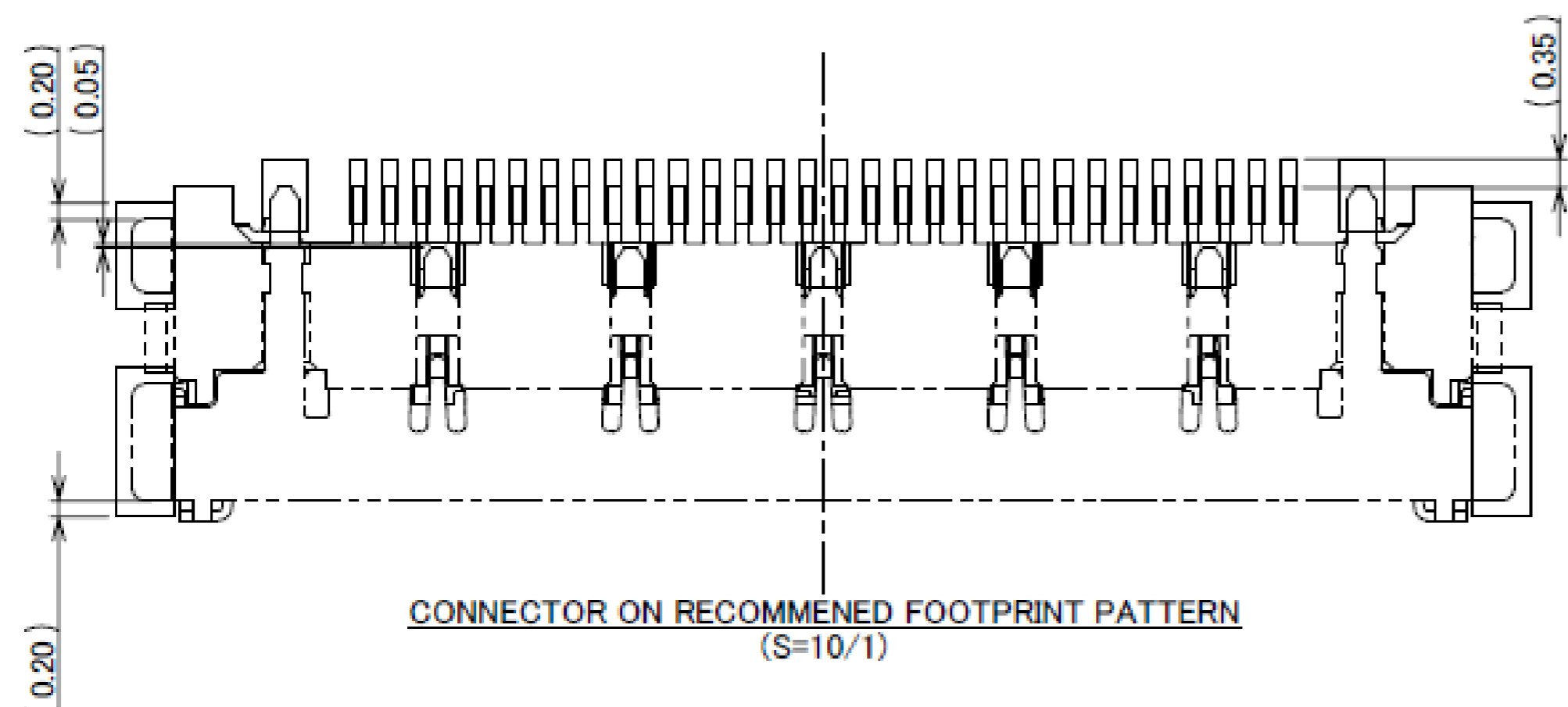

REFLOW TEMPERATURE PROFILE
SENJU METAL INDUSTRY CO., LTD. : M705-SHF(Sn96.5 Ag3.0 Cu0.5)

Rev.28

ITEMS	SPECIFICATION
APPLICABLE CABLE	MICRO-COAXIAL CABLE : AWG# 44 , 42 , 40 , 38 , 36 DISCRETE WIRE : AWG# 36 , 34 TWINAX CABLE : AWG# 40 , 42
RATING VOLTAGE	100V AC (PER CONTACT PIN)
RATING AMPERAGE (FOR CONTACT)	0.1A AC/DC [AWG#44] PER CONTACT PIN/UP TO 60 CONTACTS 0.24A AC/DC [AWG#42] PER CONTACT PIN/UP TO 50 CONTACTS 0.3A AC/DC [AWG#40] PER CONTACT PIN/UP TO 40 CONTACTS 0.5A AC/DC [AWG#38] PER CONTACT PIN/UP TO 14 CONTACTS 0.8A AC/DC [AWG#36] PER CONTACT PIN/UP TO 6 CONTACTS 1.0A AC/DC [AWG#34] PER CONTACT PIN/UP TO 4 CONTACTS ※TESTING BY A REAL MACHINE IS RECOMMENDED BECAUSE TEMPERATURE RISE MAY AFFECTED BY ACTUAL SITUATION.
OPERATING TEMPERATURE	233~358K (-40°C~85°C)
OPERATING HUMIDITY	85% MAX. (NON-CONDENSING)
CONTACT RESISTANCE	INITIAL : 180mohm MAX. (AWG#34) / AFTER TEST : \triangleleft40mohm MAX. 275mohm MAX. (AWG#36) 360mohm MAX. (AWG#38) 600mohm MAX. (AWG#40) 700mohm MAX. (AWG#42) 1080mohm MAX. (AWG#44)
GROUND SHELL RESISTANCE	INITIAL : 50mohm MAX. / AFTER TEST : \triangleleft40mohm MAX.
INSULATION RESISTANCE	INITIAL : 1000Mohm MIN. / AFTER TEST : 500Mohm MIN.
DIELECTRIC WITHSTANDING VOLTAGE	AC250V 1min
DURABILITY	30 CYCLES
MATING FORCE (INITIAL / AFTER 30 CYCLES)	10P : 7.80N MAX. 40P : 19.40N MAX. 12P : 8.20N MAX. 50P : 24.25N MAX. 20P : 9.70N MAX. 60P : 29.10N MAX. 30P : 14.55N MAX.
UNMATING FORCE (INITIAL / AFTER 30 CYCLES)	10P : 1.00N MIN. 40P : 4.00N MIN. 12P : 1.20N MIN. 50P : 5.00N MIN. 20P : 2.00N MIN. 60P : 6.00N MIN. 30P : 3.00N MIN.
CABLE RETENTION FORCE	10P : 4.90N MIN. 40P : 19.60N MIN. 12P : 5.88N MIN. 50P : 24.50N MIN. 20P : 9.80N MIN. 60P : 29.40N MIN. 30P : 14.70N MIN.
COPLANARITY	0.10 MAX.
PRODUCT SPECIFICATION	PRS-1968
TEST REPORT	TR-14122 (20525-0**E-0#) / TR-16023 (20525-2**E-0#)
PACKING STANDARD	300-824
INSTRUCTION MANUAL	HIM-09008
APPEARANCE CRITERIA No.	QLS-A***

Rev.28

Custom Products Available

RF Connector

MHF® series



Micro-coaxial/Twinax/Discrete Wire Connector

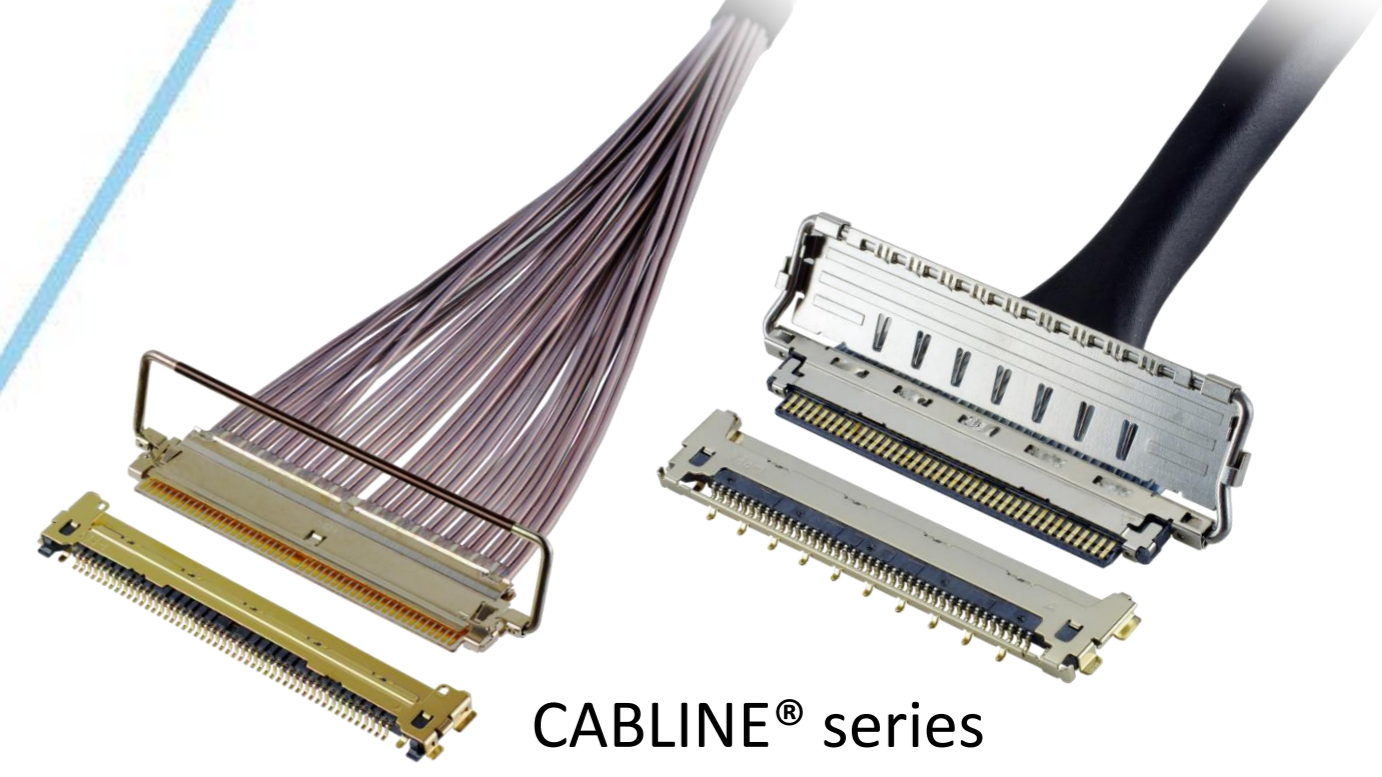

CABLINE® series



Optical Module

LIGHTPASS® series



NOVASTACK® series

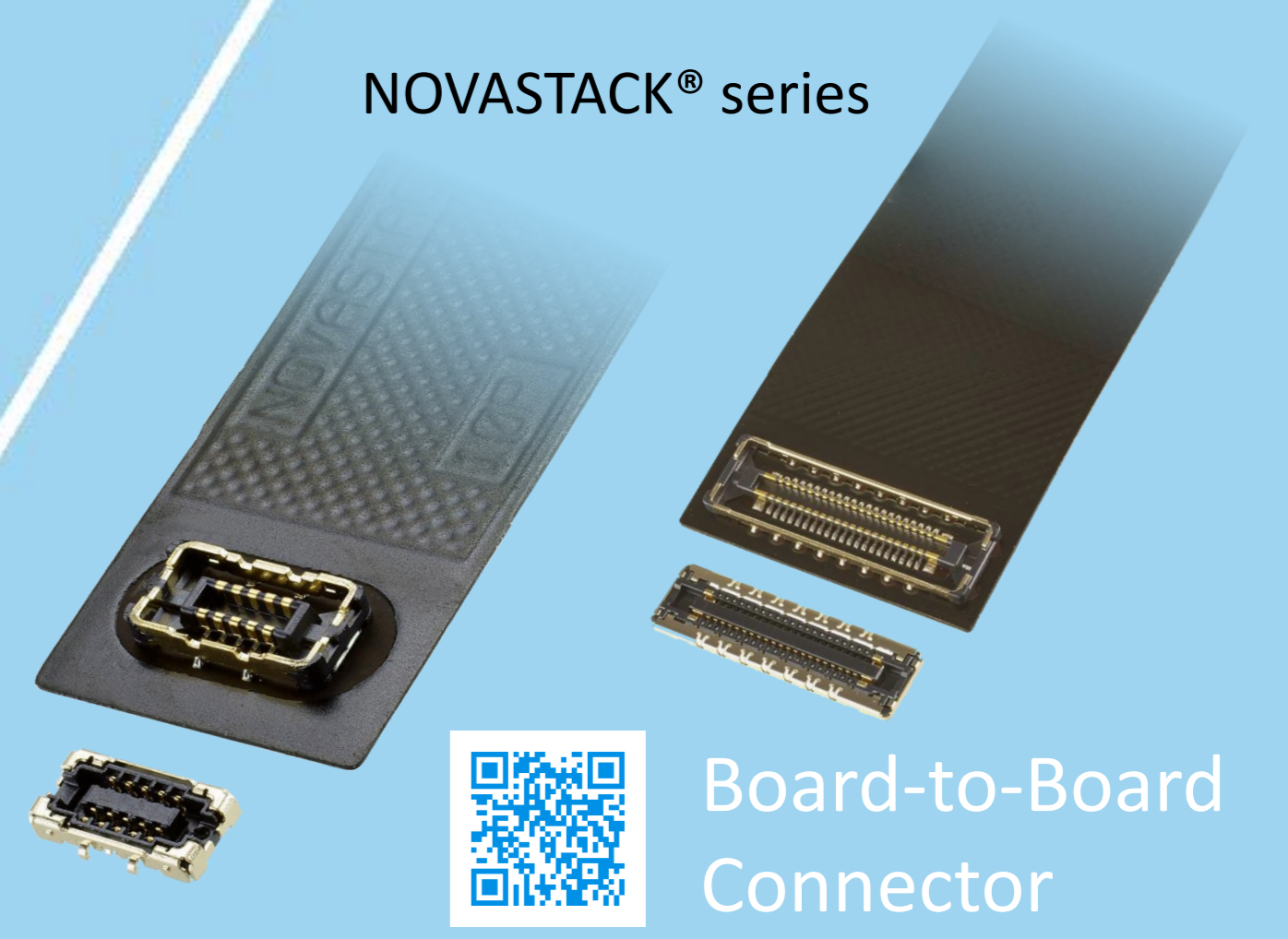

Board-to-Board Connector



Power Connector/Terminal

AP series

ISH® series



MINIFLEX® series

EVAFLEX® series



FPC FFC Connector



Inquiry



MINIDOCK® series

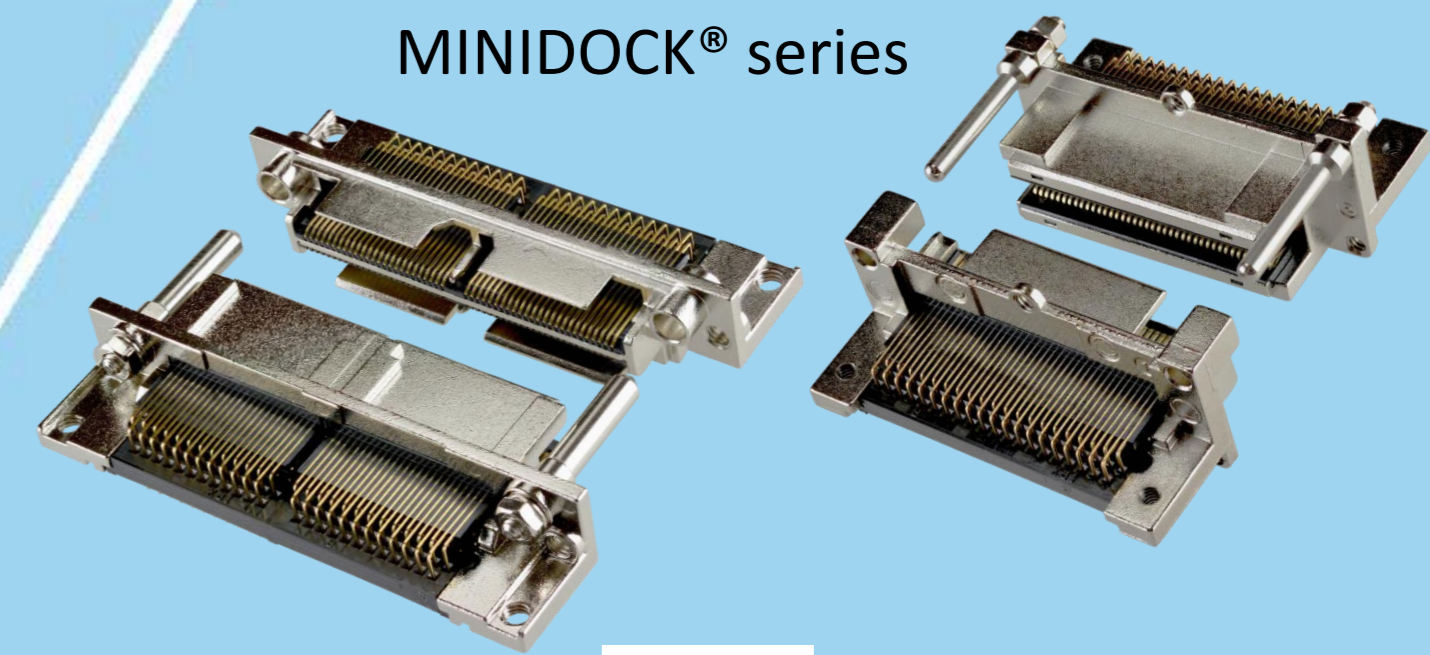

I/O Connector

I-PEX, MHF, CABLINE, LIGHTPASS, NOVASTACK, ISH, IARPB, MINIFLEX, EVAFLEX, MINIDOCKS and ZenShield are registered trademarks of I-PEX Inc. Please note that the contents in the catalog might be changed without prior notification. I-PEX Inc. assumes no responsibility for any inaccuracies or obligation to update information on these documents. Please be sure to read and understand the latest "Precautions for Use" and "Instruction Manual" before you use our products. We shall not be responsible for any defects, damages or troubles in case you use our products without following the precautions for use. Please feel free to contact our sales representatives when you use our products for any applications that require very high reliability and safety, or that relate to human life (ex. nuclear power control, aerospace, transportation, medical equipment, safety equipment etc.).

Contact your sales representative or more detailed information.

www.i-pex.com



I-PEX

© I-PEX Inc. 2024
All rights reserved